

Network Audio System

Installation/Connections
Installation/Anschluss
Installation/tiilslutning
Asennus/liitäntät
Installation/anslutningar

MEX-1GP

© 2006 Sony Corporation

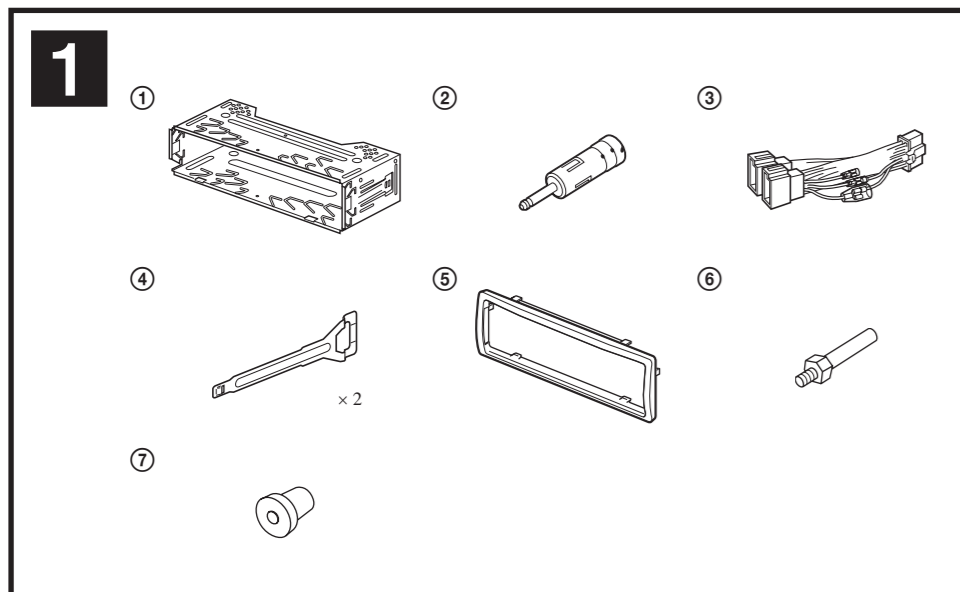

Equipment used in illustrations (not supplied)
In Abbildungen dargestellte Geräte (nicht mitgeliefert)
Udstyr brugt på billedningerne (medfølger ikke)
Kuvutuksessa käytetyt varusteet (eiivät sisälly toimitukseen)
Utrustning som används på bilderna (medföljer ej)

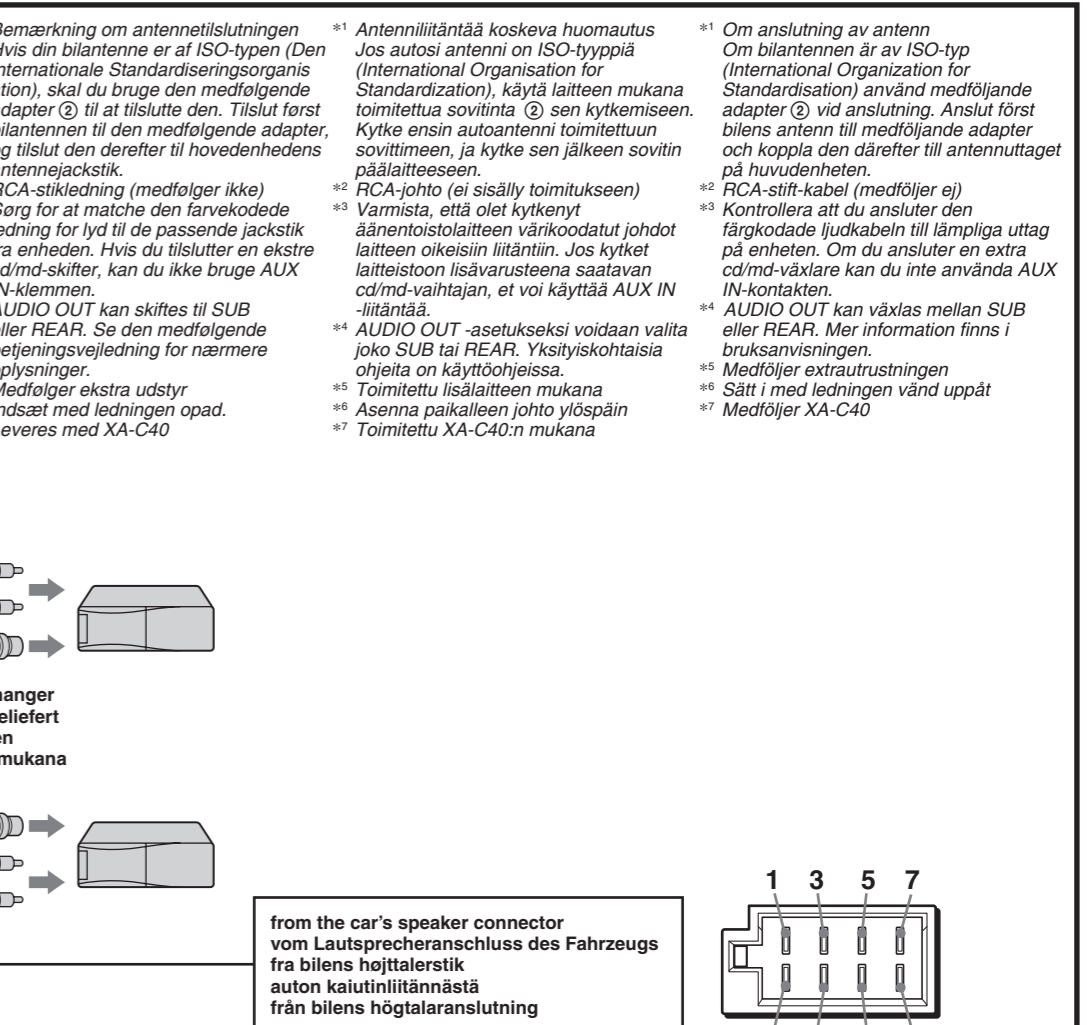
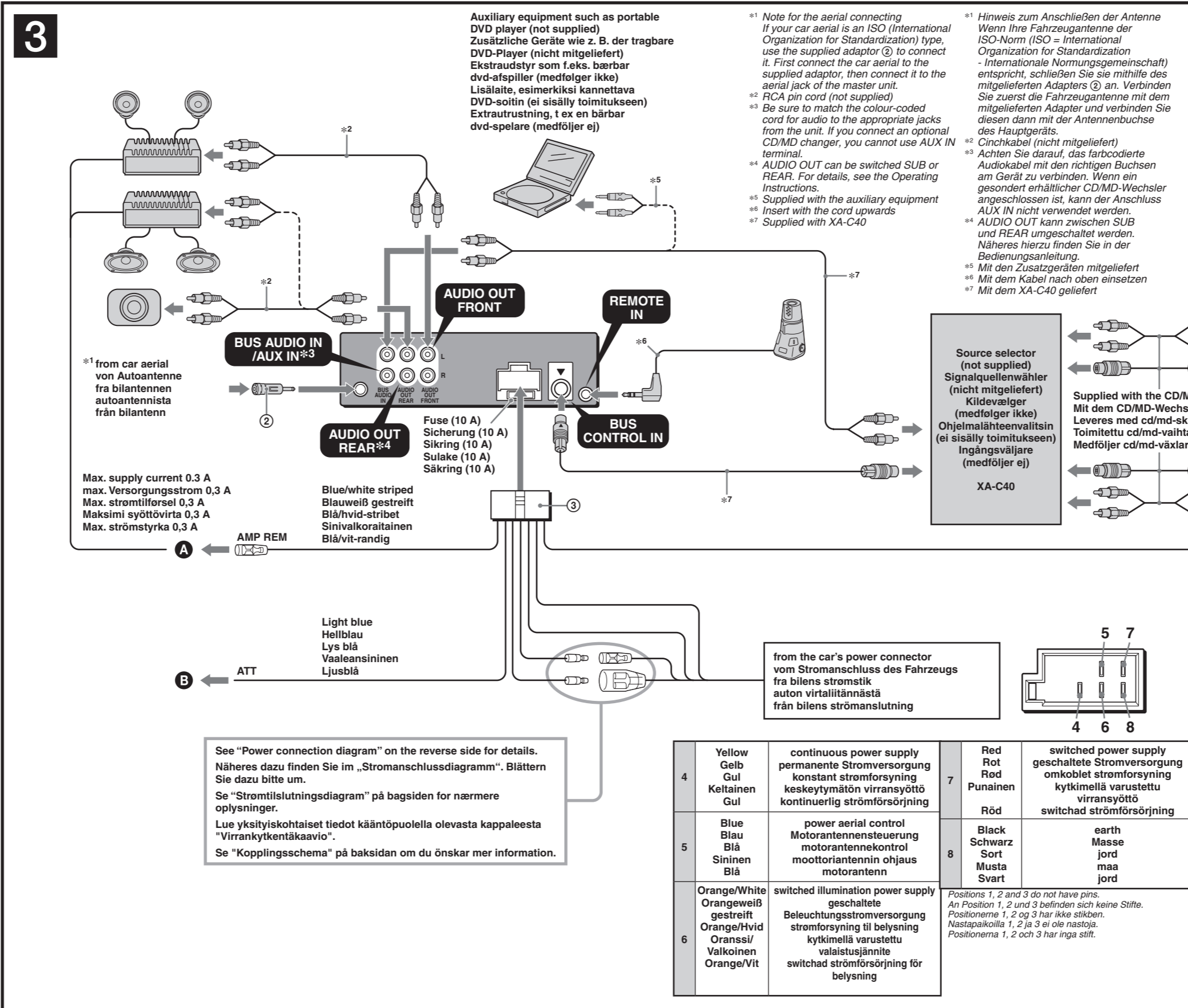
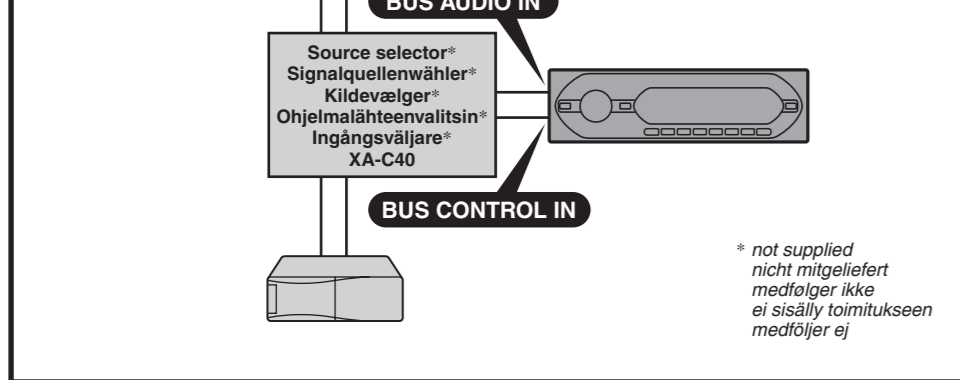
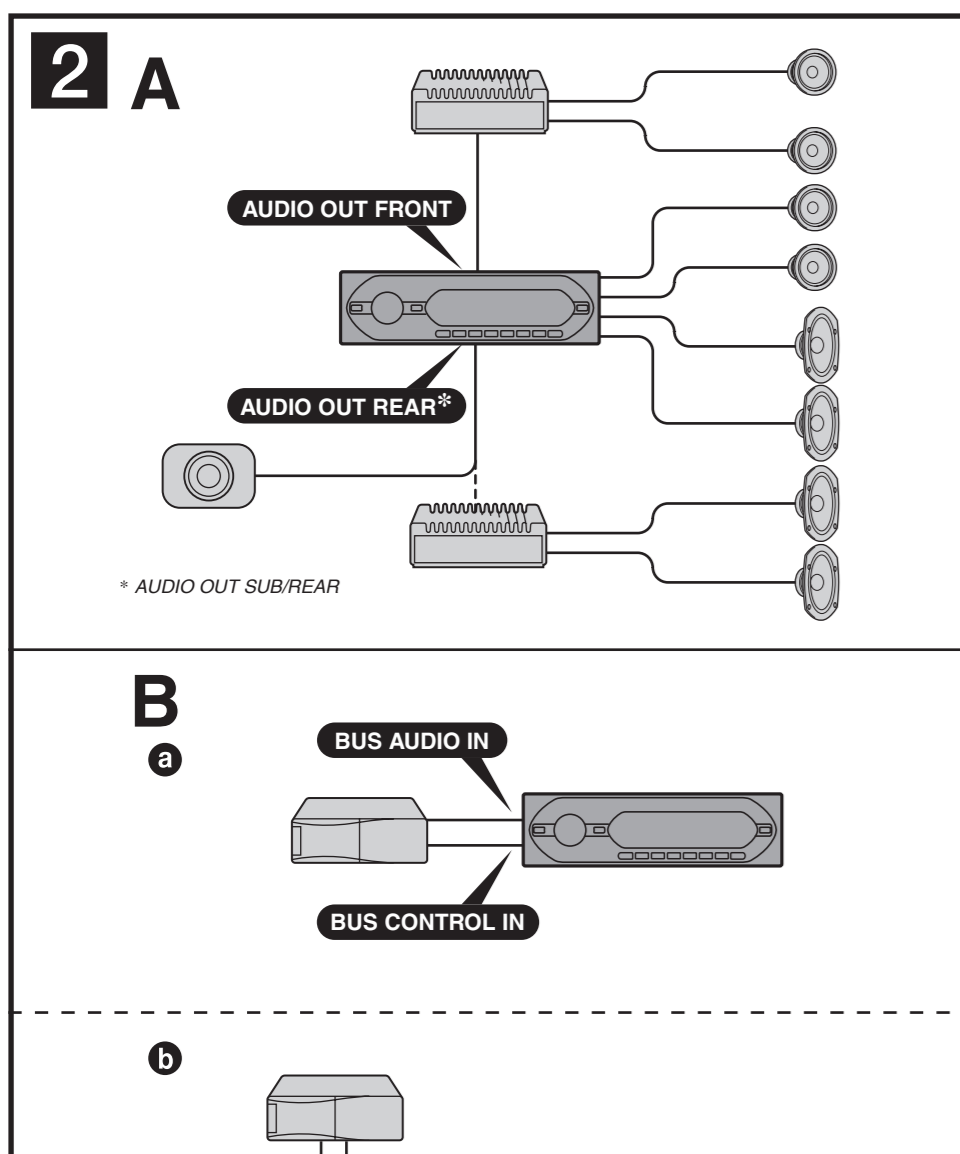
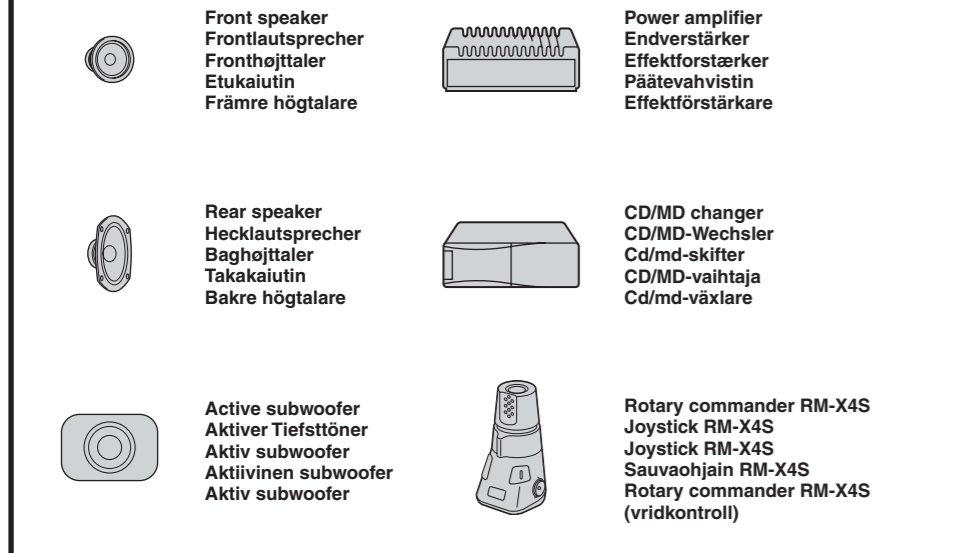

Position	Color	Function	Position	Color	Function
1	Purple/Violet	Speaker, Rear, Right	5	White	Speaker, Front, Left
2	Grey	Speaker, Rear, Left	6	White	Speaker, Front, Left
3	Green	Speaker, Front, Right	7	Green	Speaker, Rear, Left
4	Green	Speaker, Front, Right	8	Green	Speaker, Rear, Left

Cautions

This unit is designed for negative earth 12 V DC operation only. Do not get the leads under a screw, or caught in moving parts (e.g. seat railing). Before making connections, turn the car ignition off to avoid short circuits. Connect the power connecting lead (2) to the unit and speakers before connecting it to the auxiliary power connector. Run all earth leads to a common earth point. Be sure to insulate any loose unconnected leads with electrical tape for safety. When connecting this unit in combination with other stereo components, the combined car circuit's rating must be higher than the sum of each component's fuse. When no car circuits are rated high enough, connect the unit directly to the battery.

Parts list

1	Yellow/Gelb	continuous power supply permanent Stromversorgung	7	Red/Rot	switched power supply geschaltete Stromversorgung
2	Blue/Blau	power aerial control Motorantennensteuerung	8	Black/Schwarz	earth/Erde
3	Orange/White/Gelb gestreift	switched illumination power supply geschaltete Beleuchtungsstromversorgung			

Connection example

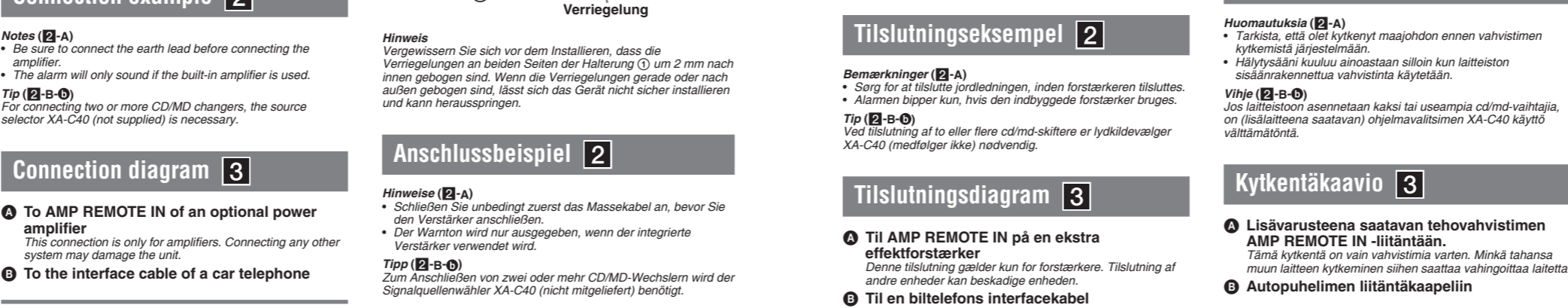

Connection diagram

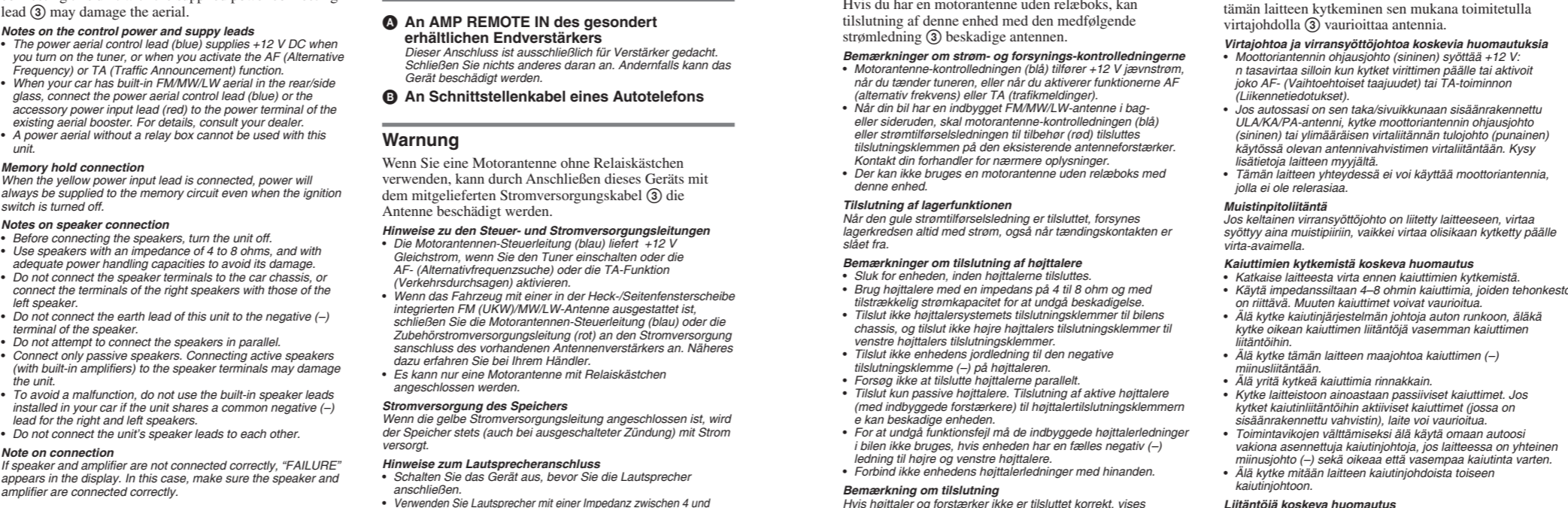

Warning

If you have a power aerial without a relay box, connecting this unit with the supplied power connecting lead (3) may damage the aerial. Notes on the control power and supply leads: The power aerial control lead (blue) supplies +12 V DC when you turn on the tuner, or when you activate the AF (Alternative Frequency) or TA (Traffic Announcement) function. When your car has built-in FM/MW/LW antenna in the rear side glass, connect the power aerial control lead (blue) to the accessory power input lead (red) to the power terminal of the existing aerial booster. For details, consult your dealer. A power aerial without a relay box cannot be used with this unit. Memory hold connection: When the yellow power input lead is connected, power will always be supplied to the memory circuit even when the ignition switch is turned off. Notes on speaker connection: Before connecting the speakers, turn the unit off. Use speakers with an impedance of 4 to 8 ohms, and with adequate power handling capacities to avoid its damage. Do not connect the speaker terminals to the car chassis, or connect the terminals of the speaker terminals with those of the left speaker. Do not connect the earth lead of this unit to the negative (-) terminal of the speaker. Do not connect to connect the speakers in parallel. Connect only passive speakers. Connecting active speakers with built-in amplifiers to the speaker terminals may damage the unit. To avoid a malfunction, do not use the built-in speaker leads installed in your car if the unit shares a common negative (-) lead for the right and left speakers. Do not connect the unit's speaker leads to each other. Note on connection: If the speaker and amplifier are not connected correctly, "FAILURE" appears in the display. In this case, make sure the speaker and amplifier are connected correctly.

Forholdsregler

Enheden er kun beregnet til drift med negativ jordforbundet 12 V jævrstrøm. Pas på ikke at få ledningerne under en skrue eller mellem bevægelige dele (f.eks. en sædeskinne). Inden du foretager tilslutning, skal du slå bilens tænding fra for at undgå kortslutninger. Tilknyt stromledningen (2) til enheden og højttalerne, inden den tilsluttes til strømtilførsel til ekstraudstyr. Træk samtlige jordforbindelsesledninger til et fælles jordforbindelsespunkt. Ved tilslutning af denne enhed sammen med andre stereo komponenter skal det tilsættede bilkreds have højere sikringsmerkeklade end summen af de enkelte komponenters mærkeklade. Hvis der ikke er et elektrisk bilkreds med sikringsmerkeklade, der er tilstrækkeligt højt, skal enheden tilsluttes direkte til batteriet. Bemærkninger om strømforlyngsledning (gul) Når du tilslutter af denne enhed sammen med andre stereo komponenter skal det tilsættede bilkreds have højere sikringsmerkeklade end summen af de enkelte komponenters mærkeklade. Hvis der ikke er et elektrisk bilkreds med sikringsmerkeklade, der er tilstrækkeligt højt, skal enheden tilsluttes direkte til batteriet.

Muistutuksia

Tämä laite on suunniteltu ainoastaan 12 V:n tasavirtakytkä toimivien autotilaisuuksien käyttöön. Tarkista, ettei mikään johdo jää naruun alle tai piilee tarttumalla liikkuvien osien (esim. istuimen kiskojen) välillä. Kytkä virta-avaimella virta pois ennen liittäjän tekemistä oikosulkujen välttämiseksi. Kytkä yksittäisiä johtoja vastaavaan liittämiseen ennen kuin se kytketään ylimääräiseen virtaliitäntään. Kytkä kaikki maadoitusjohdot samaan maadoituskaaviin. Eristä turvavälikätkä kaikki irrallaan olevat, kytkemättömät johdot sähkötoimilla. Virtaliitäntöä (keltainen) koskevia huomioita Kun tämä laite kytketään toisiin stereotilaisuuksiin, on kytkettävien virtajärjestelmien arvo tulee olla suurempi kuin kaikkien laitteiden sulakkeiden summa. Ellei mikään arvo riittäisi ole avoimien tarpeeksi suuri, kytkä laite suoraan akkuun. Osaluettelo Luettelossa olevien osien numerot vastavat ohjeissa annettuja numeroita. Konsoli ja suojarami on kiinnitettävä laitteeseen kiinnittämällä konsolin suojarami suoraan konsolin ja suojarami siittä irrotusavainten avulla. Lisävarusteita on kappaleissa "Suojarami ja konsolin irrotus" ja "Leikkien kiinnittäminen". Säilytä irrotusavainta (2) tulvava käyttöä varten, koska niitä tarvitaan myös laitteen irrottamiseen autosta. Muistutus Käsittele konsolia (3) varovasti välttäessä loppuun saattamista.

Liitäntäesimerkki

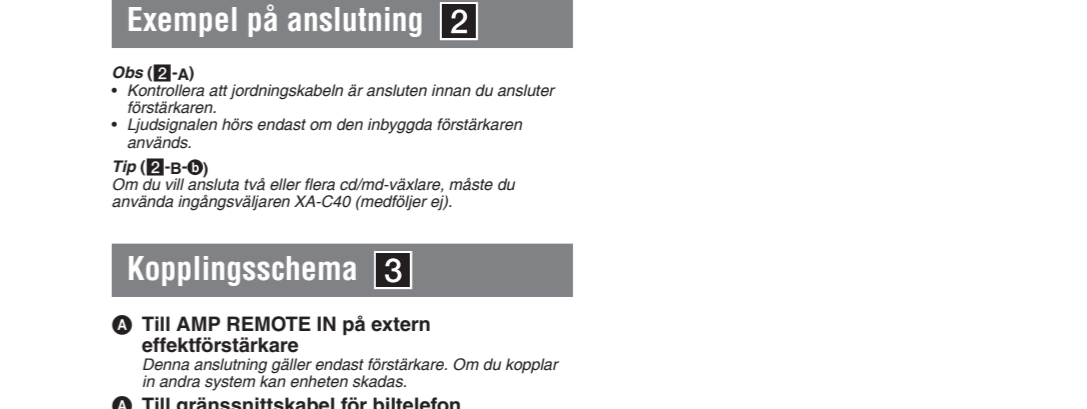

Exempel på anslutning

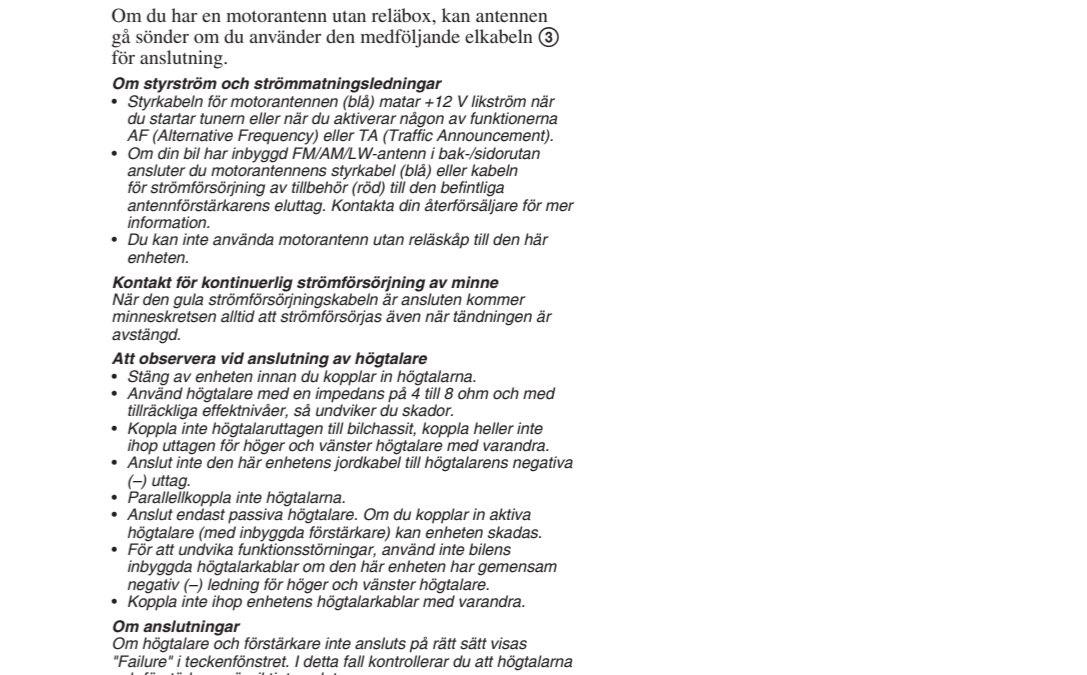

Warning

If you have a power aerial without a relay box, connecting this unit with the supplied power connecting lead (3) may damage the aerial. Notes on the control power and supply leads: The power aerial control lead (blue) supplies +12 V DC when you turn on the tuner, or when you activate the AF (Alternative Frequency) or TA (Traffic Announcement) function. When your car has built-in FM/MW/LW antenna in the rear side glass, connect the power aerial control lead (blue) to the accessory power input lead (red) to the power terminal of the existing aerial booster. For details, consult your dealer. A power aerial without a relay box cannot be used with this unit. Memory hold connection: When the yellow power input lead is connected, power will always be supplied to the memory circuit even when the ignition switch is turned off. Notes on speaker connection: Before connecting the speakers, turn the unit off. Use speakers with an impedance of 4 to 8 ohms, and with adequate power handling capacities to avoid its damage. Do not connect the speaker terminals to the car chassis, or connect the terminals of the speaker terminals with those of the left speaker. Do not connect the earth lead of this unit to the negative (-) terminal of the speaker. Do not connect to connect the speakers in parallel. Connect only passive speakers. Connecting active speakers with built-in amplifiers to the speaker terminals may damage the unit. To avoid a malfunction, do not use the built-in speaker leads installed in your car if the unit shares a common negative (-) lead for the right and left speakers. Do not connect the unit's speaker leads to each other. Note on connection: If the speaker and amplifier are not connected correctly, "FAILURE" appears in the display. In this case, make sure the speaker and amplifier are connected correctly.

