

Digital Video Camera Recorder

Operating Instructions

Before operating the unit, please read this manual thoroughly,
and retain it for future reference.

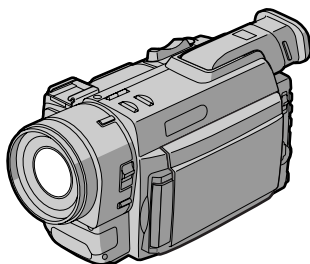

DCR-TRV900

©1998 by Sony Corporation

Mini **DV** Digital
Video
Cassette

Handycam Vision™

InfoLITHIUM

C/M Cassette
Memory **i**

MEMORY STICK

Welcome !

Congratulations on your purchase of this Sony Handycam Vision™ camcorder. With your Handycam Vision, you can capture life's precious moments with superior picture and sound quality.

Your Handycam Vision is loaded with advanced features, but at the same time it is very easy to use. You will soon be producing home video that you can enjoy for years to come.

WARNING

To prevent fire or shock hazard, do not expose the unit to rain or moisture.

To avoid electrical shock, do not open the cabinet. Refer servicing to qualified personnel only.

-
- IBM PC/AT is a registered trademark of International Business Machines Corporation of the U.S.A.
 - MS-DOS and Windows are registered trademarks licensed to Microsoft Corporation, registered in the U.S.A. and other countries.
 - Macintosh is a trademark licensed to Apple Computer, Inc., registered in the U.S.A. and other countries.
 - All other product names mentioned herein may be the trademarks or registered trademarks of their respective companies.

Furthermore, "™" and "®" are not mentioned in each case in this manual.

Table of contents

Before you begin	
Using this manual	4
Checking supplied accessories	6
Getting started	
Installing and charging the battery pack	7
Inserting a cassette	11
Basic operations	
Camera recording	12
Attaching the lens hood	14
Using the zoom feature	14
Selecting the start/stop mode	15
Shooting with the LCD screen	16
Letting the subject monitor the shot	17
Self-timer recording	18
Hints for better shooting	19
Checking the recorded picture	21
Playing back a tape	22
Searching for the end of the picture	24
Advanced operations	
Using alternative power sources	25
Using the house current	25
Using a car battery	26
Changing the mode settings	27
—for camera recording—	
Photo recording	33
Shooting with all the pixels - PROG. SCAN ..	35
Using the FADER function	36
Shooting with backlighting	38
Using the wide mode function	39
Enjoying picture effect	40
Recording with various effects	
- digital effect	42
Shooting with manual adjustment	44
Using the PROGRAM AE function	54
Focusing manually	57
Interval recording	59
Cut recording	61
Superimposing a title	63
Making a custom title	66
Labeling a cassette	68
—for playing back/editing—	
Watching on a TV screen	70
Viewing the picture with the picture effect	72
Viewing the picture with the digital effect	73
Searching the boundaries of recorded tape with date - date search	74
Searching the boundaries of recorded tape with title - title search	76
Searching for a photo	
- photo search/photo scan	77
Returning to a pre-registered position	80
Displaying recording data	
- data code function	81
Editing onto another tape	82
Editing partially on a mini DV tape	
- DV synchro-editing	84
Recording from a VCR or TV	86
Replacing recording on a tape	
- insert editing	87
Audio dubbing	88
Memory card slot operations	
Using the memory card slot - introduction	91
Recording an image from a mini DV tape as a still image	98
Copying still images from a mini DV tape	
- photo save	100
Recording still images on PC cards (not supplied) - memory photo recording ..	102
Viewing a still picture	
- memory photo playback	105
Preventing accidental erasure	
- PROTECT	108
Deleting images	109
Copying the image recorded with the memory card slot to mini DV tapes	112
Playing back images in a continuous loop	
- SLIDE SHOW	114
Additional information	
Usable cassettes and playback modes	116
Charging the vanadium-lithium battery in the camcorder	117
Resetting the date and time	118
Simple setting of clock by time difference	119
Tips for using the battery pack	120
Maintenance information and precautions	123
Using your camcorder abroad	126
Trouble check	127
Self-diagnosis function	132
Specifications	133
Identifying the parts	134
Warning indicators	143
Index	145

When you use Memory Sticks (not supplied),
see page 91 for details.

Using this manual

As you read through this manual, buttons and settings on the camcorder are shown in capital letters.

e.g., Set the POWER switch to CAMERA.

Note on Cassette Memory

This camcorder is based on the DV format. You can only use mini DV cassettes with this camcorder. We recommend you to use a tape with cassette memory **CIII**.

The functions which depend on whether the tape has the cassette memory or not are:

- End Search (p. 21, 24)
- Date Search (p. 74)
- Photo Search (p. 77).

The functions you can operate only with the cassette memory are:

- Title Search (p. 76)
- Superimposing a title (p. 63)
- Making a custom title (p. 66)
- Labeling a cassette (p. 68).

For details, see page 116.

Note on TV color systems

TV color systems differ from country to country. To view your recordings on a TV, you need an NTSC system-based TV.

Precaution on copyright

Television programs, films, video tapes, and other materials may be copyrighted.

Unauthorized recording of such materials may be contrary to the provision of the copyright laws.

Precautions on camcorder care

- The LCD screen and/or the color viewfinder are manufactured using high-precision technology. However, there may be some tiny black points and/or bright points (red, blue or green in color) that constantly appear on the LCD screen and/or in the viewfinder. These points are normal in the manufacturing process and do not affect the recorded picture in any way. Over 99.99% are operational for effective use.
- Do not let the camcorder get wet. Keep the camcorder away from rain and sea water. Letting the camcorder get wet may cause the unit to malfunction, and sometimes this malfunction cannot be repaired [a].
- Never leave the camcorder exposed to temperatures above 60°C, such as in a car parked in the sun or under direct sunlight [b].

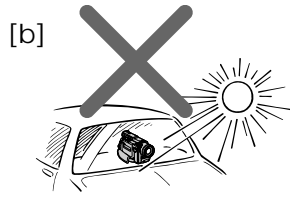
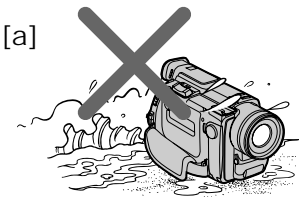

Checking supplied accessories

Check that the following accessories are supplied with your camcorder.

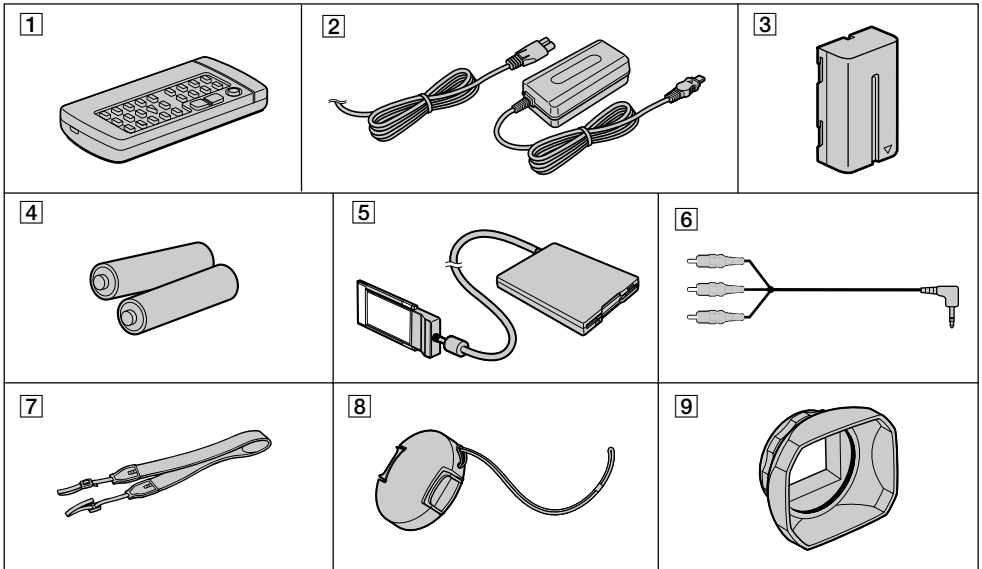

1 Wireless Remote Commander (1) (p. 139)

2 AC-L10A/L10C AC power adaptor (1),
Power cord (1) (p. 8, 25)
The shape of the plug varies from region to
region.

3 NP-F330 battery pack (1) (p. 7)

4 R6 (size AA) battery for Remote
Commander (2) (p. 139)

5 Floppy disk adapter (1) (p. 91)

6 A/V connecting cable (1) (p. 70, 82)

7 Shoulder strap (1) (p. 140)

8 Lens cap (1) (p. 12)

9 Lens hood (1) (p. 14)

Contents of the recording cannot be compensated if recording or playback is not made due to a malfunction of the camcorder, video tape, etc.

Installing and charging the battery pack

Before using your camcorder, you first need to install and charge the battery pack. To charge the battery pack, use the supplied AC power adaptor.

This camcorder operates only with the “InfoLITHIUM” battery pack.
“InfoLITHIUM” is a trademark of Sony Corporation.

Installing the battery pack

- (1) Lift up the viewfinder.
- (2) Insert the battery pack in the direction of the ▼ mark on the battery pack. Slide the battery pack down until it is locked.

Attach the battery pack to the camcorder securely.

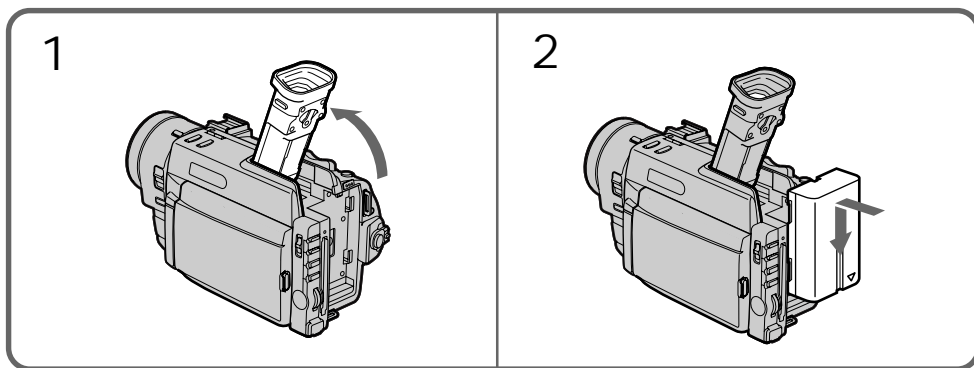

Note on installing the NP-F730/F750/F930/F950 battery pack
Use the camcorder while stretching out the viewfinder.

Note on the battery pack
Do not carry the camcorder by grasping the battery pack.

Installing and charging the battery pack

Charging the battery pack

Charge the battery pack on a flat surface without vibration. The battery pack is charged a little in the factory.

- (1) Open the DC IN jack cover and connect the supplied AC power adaptor to the DC IN jack with the plug's ▲ mark up.
- (2) Connect the power cord to the AC power adaptor.
- (3) Connect the power cord to a wall outlet.
- (4) Set the POWER switch to OFF. Remaining battery time is indicated by the minutes on the display window. Charging begins.

When the remaining battery indicator becomes , normal charge is completed. For full charge, which allows you to use the battery longer than usual, leave the battery pack attached for about 1 hour after normal charge is completed until FULL appears in the display window.

Before using the camcorder with the battery pack, unplug the AC power adaptor from the DC IN jack of the camcorder. You can also use the battery pack before it is completely charged.

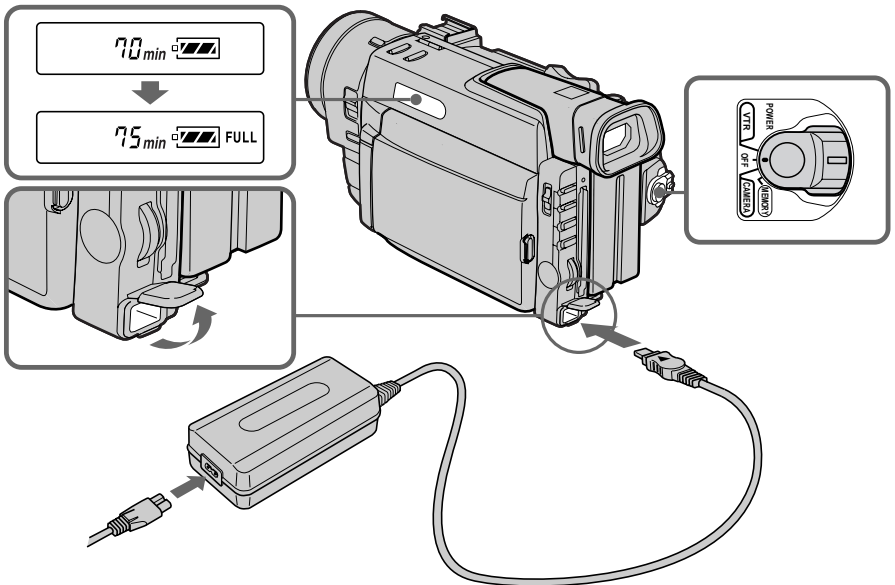

Notes

- “--- min” appears on the display window until the camcorder calculates remaining battery time.
- Remaining battery time indication on the display window roughly indicates the recording time with the viewfinder. Use it as a guide. It may differ from the actual recording time.

Charging time

Battery pack	Charging time *
NP-F330 (supplied)	150 (90)
NP-F530	210 (150)
NP-F550	210 (150)
NP-F730	300 (240)
NP-F750	300 (240)
NP-F930	390 (330)
NP-F950	390 (330)

The time required for a normal charge is indicated in parentheses.

* Approximate minutes to charge an empty battery pack using the supplied AC power adaptor. (Lower temperatures require a longer charging time.)

Battery life

While using with viewfinder

Battery pack	Continuous recording time *	Typical recording time **
NP-F330 (supplied)	75 (70)	40 (35)
NP-F530	120 (110)	60 (55)
NP-F550	150 (135)	75 (70)
NP-F730	270 (245)	140 (130)
NP-F750	315 (275)	165 (145)
NP-F930	420 (375)	220 (195)
NP-F950	485 (440)	255 (230)

While using with LCD

Battery pack	Continuous recording time *	Typical recording time **	Playing time with LCD
NP-F330 (supplied)	60 (50)	30 (25)	75 (70)
NP-F530	95 (85)	50 (45)	120 (110)
NP-F550	120 (105)	65 (55)	150 (135)
NP-F730	210(190)	115 (105)	270 (245)
NP-F750	250 (220)	140 (120)	315 (275)
NP-F930	325 (295)	180 (165)	420 (375)
NP-F950	375 (335)	210 (185)	485 (440)

Numbers in parentheses indicate the time when you use a normally charged battery. Battery life will be shorter if you use the camcorder in a cold environment.

* Approximate continuous recording time indoors.

** Approximate minutes when recording while you repeat recording start/stop, zooming and turning the power on/off. The actual battery life may be shorter.

Installing and charging the battery pack

Notes on remaining battery time indication during recording

- Remaining battery time is displayed on the LCD screen or in the viewfinder. However, the indication may not be displayed properly, depending on using conditions and circumstances.
- When you close the LCD panel or open it, it takes about 1 minute for the correct remaining time to be displayed.

To remove the battery pack

Lift up the viewfinder. While pressing **BATT RELEASE**, slide the battery pack in the direction of the arrow.

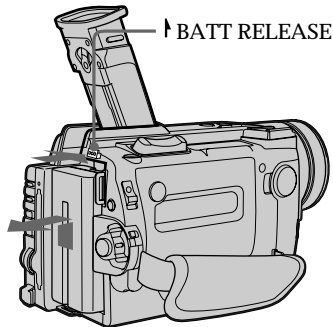

Inserting a cassette

You can use mini DV cassette with ^{Mini}**DV** logo* only.
Make sure that the power source is installed.

- (1) While pressing the small blue button on the EJECT switch, slide it in the direction of the arrow. The cassette compartment automatically opens.
- (2) Insert a cassette with the window facing out.
- (3) Close the cassette compartment by pressing the "PUSH" mark on the cassette compartment.

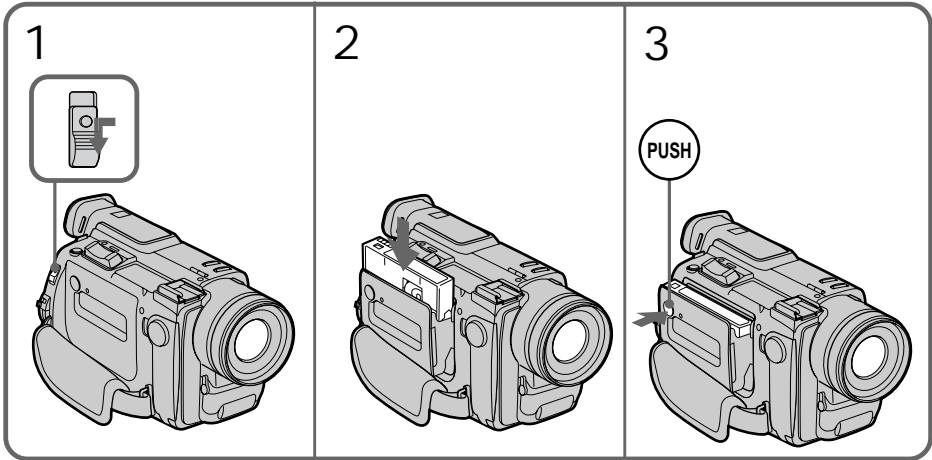

* ^{Mini}**DV** is a trademark.



To eject the cassette

While pressing the small blue button on the EJECT switch, slide it in the direction of the arrow.

To prevent accidental erasure

Slide and open the tab on the cassette to expose the red mark. If you try to record with the red mark exposed, the  and  indicators flash on the LCD screen or in the viewfinder, and you cannot record on the tape. To re-record on this tape, slide and close the tab to cover the red mark.

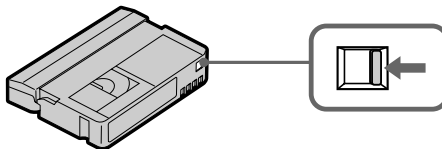

Camera recording

Make sure that the power source is installed and a cassette is inserted and that the START/STOP MODE selector inside the LCD panel is set to **U**. Before you record one-time events, you had better make a trial recording to make sure that the camcorder is working correctly. When you use the camcorder for the first time, power on it and reset the date and time to your time before you start recording (p. 118).

- (1) Remove the lens cap by pressing both knobs on its sides and pull the lens cap string to fix it.
- (2) While pressing the small green button on the POWER switch, set it to CAMERA. The camcorder is set to Standby mode.
- (3) Press START/STOP.

The camcorder starts recording. "REC" appears on the LCD screen or in the viewfinder. The camera recording lamp on the front of the camcorder also lights up.

You can also select Recording mode, SP (standard play) mode or LP (long play) mode. Set REC MODE in the menu system according to the length of your planned recording before you start.

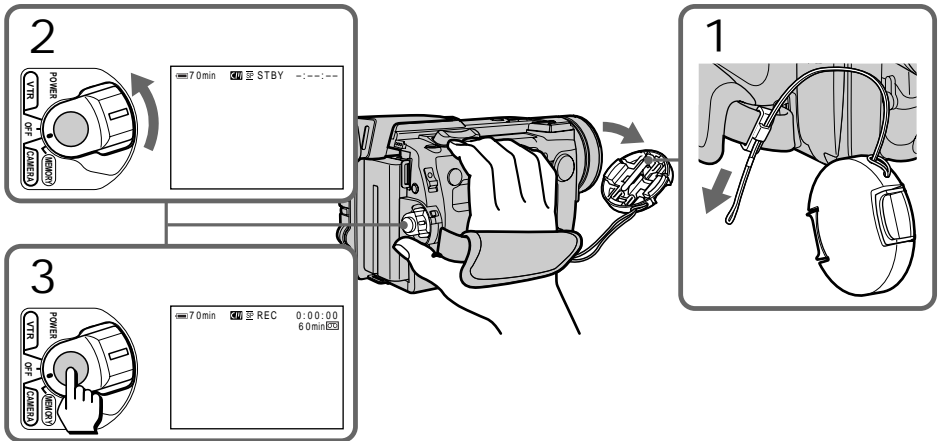

To stop recording momentarily [a]

Press START/STOP. The "STBY" indicator appears on the LCD screen or in the viewfinder (Standby mode).

To finish recording [b]

Set the POWER switch to OFF. Then, eject the cassette and remove the battery pack.



To focus the viewfinder lens

If you cannot see the indicators in the viewfinder clearly, or after someone else has used the camcorder, focus the viewfinder lens. Move the viewfinder lens adjustment lever so that the indicators in the viewfinder come into sharp focus.

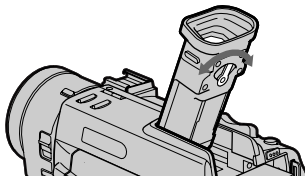

Note on Standby mode

If you leave the camcorder in Standby mode for 5 minutes while the cassette is inserted, the camcorder turns off automatically. This prevents wearing down the battery and wearing out the tape. To resume Standby mode, while pressing the small green button on the POWER switch, set it to OFF once, and then to CAMERA. To start recording, press START/STOP.

Note on the progressive mode

If you modify the images on your personal computer or play the images back as still pictures, we recommend you to set PROG. SCAN to ON in the menu system before shooting. The picture quality may improve in this mode, but if you shoot a moving subject, the image may shake when it is played back.

Note on the lock knob

When you set the lock knob to the left position, the POWER switch will not be set to MEMORY accidentally.



Lock knob

Note on Recording mode

This camcorder records and plays back in SP (standard play) mode and in LP (long play) mode. Select SP or LP in the menu system. In LP mode, you can record 1.5 times as long as in SP mode.

Notes on LP mode

- We recommend to use this camcorder to play back a tape recorded on this camcorder. If a tape recorded on other camcorder is played back on this camcorder, or vice versa, mosaic-pattern noise may appear.
- When you record in SP and LP modes on one tape or you record some scenes in LP mode, the playback picture may be distorted or the time code may not be written properly between scenes.
- When you record in LP mode, we recommend you to use a Sony Excellence/Master mini DV cassette so that you can get the most out of your camcorder.
- You cannot make audio dubbing on a tape recorded in LP mode. Use the SP mode for the tape to be audio dubbed.

Notes on the time code

- The time code indicates the recording or playback time, "0:00:00" (hours : minutes : seconds) in CAMERA mode and "0:00:00:00" (hours : minutes : seconds : frames) in VTR mode.
- Be sure not to make a blank portion when recording, because the time code will start from "0:00:00:00" again.
- This camcorder uses the drop frame mode.

Note on the beep sound

Note that the beep sound is not recorded on the tape. If you do not want to hear the beep sound, select OFF in the menu system.

Note on remaining tape indicator

The indicator may not be displayed accurately depending on the tape. Though the indicator does not appear at the time of recording, it will appear in a few seconds.

Attaching the lens hood

To record fine pictures, we recommend you to attach the lens hood, no matter where you shoot. You can also attach the lens cap when using the lens hood.

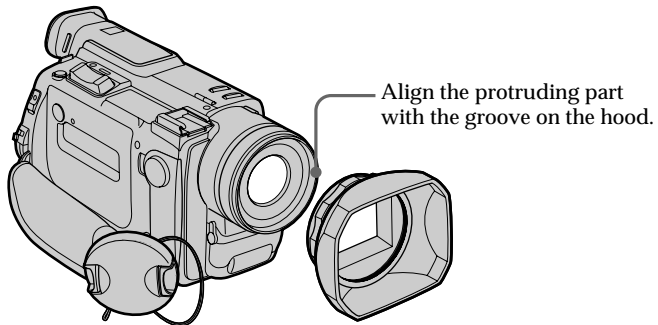

If the lens hood is not attached properly

The four corners of the screen may be eclipsed by the lens hood.

Using the zoom feature

Zooming is a recording technique that lets you change the size of the subject in the scene. For more professional-looking recordings, use the zoom function sparingly.

"T" side: for telephoto (subject appears closer)

"W" side: for wide-angle (subject appears farther away)

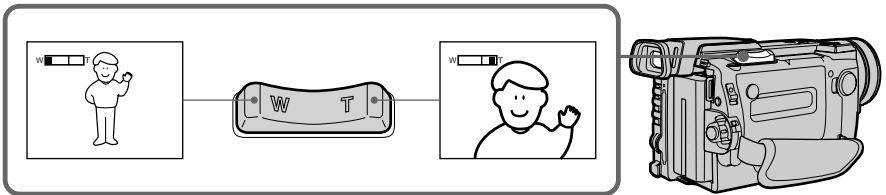

Zooming speed (Variable speed zooming)

Press the power zoom lever a little for a relatively slow zoom; press it still more for a high-speed zoom.

When you shoot a subject using a telephoto zoom

If you cannot get a sharp focus while in extreme telephoto zoom, press the "W" side of the power zoom lever until the focus is sharp. You can shoot a subject that is at least about 80 cm away from the lens surface in the telephoto position, or about 1 cm away in the wide-angle position.

Zooming of more than 12x – digital zoom

- If you set the D ZOOM function to ON in the menu system, you can perform zooming of more than 12x performed digitally. It is set to OFF at the factory.
- You cannot use the digital zoom when you set PROG. SCAN to ON in the menu system.
- The right side [a] of the power zoom indicator shows the digital zooming zone, and the left side [b] shows the optical zooming zone. If you set the D ZOOM function to ON, the [a] zone appears.

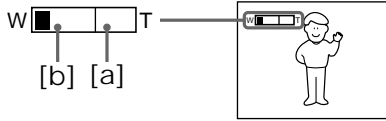

Selecting the start/stop mode

Your camcorder has two modes besides normal start/stop mode. These modes enable you to take a series of quick shots resulting in a lively video.

(1) While pressing OPEN, open the LCD panel.

(2) Set START/STOP MODE to the desired mode.

 : Recording starts when you press START/STOP, and stops when you press it again (factory setting).

 ANTI GROUND SHOOTING : The camcorder records only while you press down START/STOP so that you can avoid recording unnecessary scenes.

5SEC : When you press START/STOP, the camcorder records for 5 seconds and then stops automatically.

(3) Press START/STOP. Recording starts.

If you selected 5SEC, five dots appear on the LCD screen or in the viewfinder. The dots disappear at a rate of one per second as illustrated below. When five seconds elapse and all the dots disappear, the camcorder switches to Standby mode automatically.

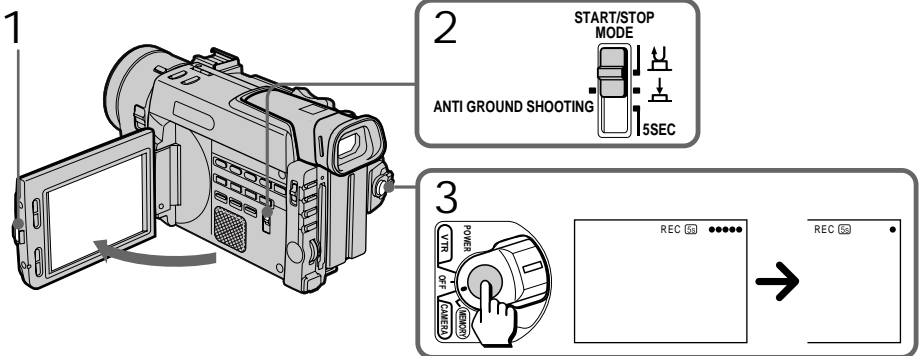

To extend the recording time in 5SEC mode

Press START/STOP again before all the dots disappear. Recording continues for about 5 seconds from the moment you press START/STOP.

Notes on 5SEC recording

- If you have turned off the indicators on the LCD screen, the dots do not appear.
- When selecting  ANTI GROUND SHOOTING or “5SEC,” the fader function does not work.
- When selecting “5SEC,” the time code is not displayed.

Shooting with the LCD screen

You can also record the picture while looking at the LCD screen.

When using the LCD screen, the viewfinder turns off automatically except in mirror mode.

You cannot monitor the sound from the speaker during recording.

(1) While pressing OPEN, open the LCD panel.

(2) Adjust angle of the LCD panel.

The LCD panel moves about 90 degrees to this side and about 180 degrees to the other side.

To adjust the brightness of the LCD screen, press LCD BRIGHT + or -.

The battery life is longer when the LCD panel is closed. Use the viewfinder instead of the LCD screen to save the battery power.

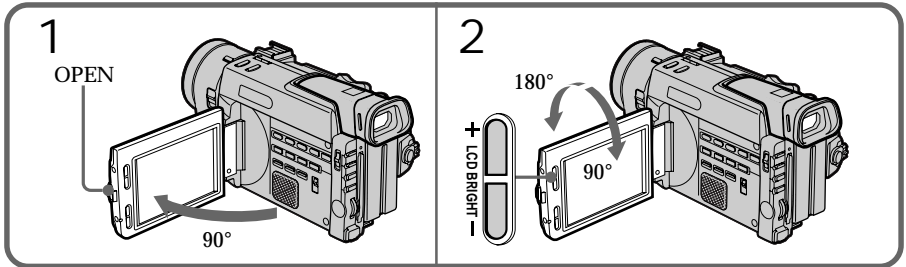

Backlighting the LCD screen

If the LCD screen is insufficiently illuminated even after adjusting LCD BRIGHT, select LCD B. L. in the menu system and set to BRIGHT. You can select LCD B. L. only while using the battery pack as a power source.

Notes on the LCD panel

- When closing the LCD panel, turn it vertically until it clicks [a].
- When turning the LCD panel, turn it always vertically; otherwise, the camcorder body may be damaged or the LCD panel may not close properly [b].
- Close the LCD panel completely when not in use.
- Do not push nor touch the LCD panel while operating the camcorder.
- You may find it difficult to view the LCD screen due to glare when using the camcorder outdoors.

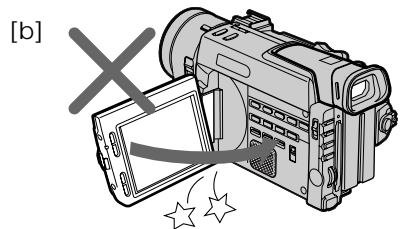
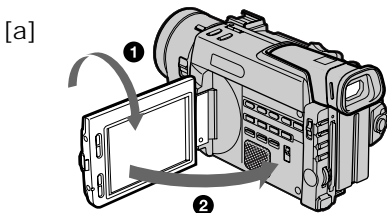

Letting the subject monitor the shot

You can turn the LCD panel over so that it faces the other way and you can let the subject monitor the shot while shooting with the viewfinder.

Turn the LCD panel up vertically. When you turn the LCD panel 180 degrees, the ☺ indicator appears on the LCD screen (mirror mode) and the time code and remaining tape indicators disappear.

You can also use the Remote Commander.

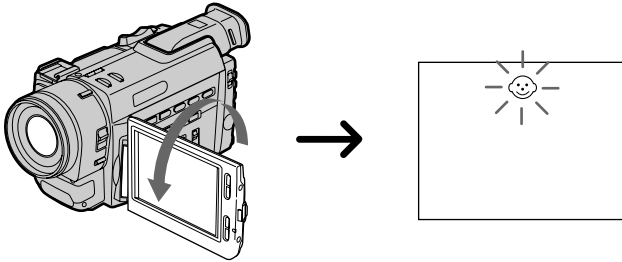

To cancel mirror mode

Turn the LCD panel down toward the camcorder body.

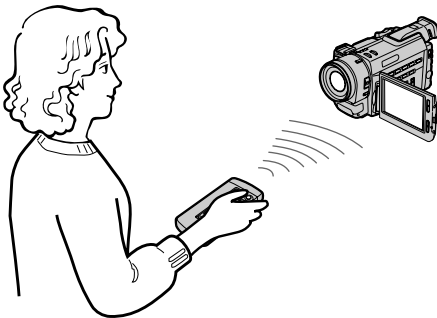

Notes on mirror mode

- When you turn the LCD panel about 135 degrees to 180 degrees, the camcorder enters mirror mode.
- Using the mirror mode, you can record yourself while watching yourself on the LCD screen.
- The picture on the LCD screen looks like a mirror-image while recording in mirror mode. The STBY indicator appears as **II●** and REC as **●**. Other indicators appear as mirror-image. Some indicators may not appear in mirror mode.
- While recording in mirror mode, you cannot operate the following functions: MENU, TITLE, and ZERO SET MEMORY on the Remote Commander.



Self-timer recording

You can make a recording with the self-timer. This mode is useful when you want to record yourself.

- (1) Press  (self-timer) to display  (self-timer) on the LCD screen or in the viewfinder while the camcorder is in Standby mode.
- (2) Press START/STOP.

Self-timer starts counting down to 10 with a beep sound. In the last two seconds of the countdown, the beep sound gets faster, then recording starts automatically at the time you set.

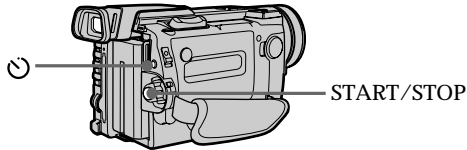

To stop self-timer recording



Press START/STOP.

Use the Remote Commander for convenience.

To record still pictures using the self-timer

Press PHOTO in step 2.

To cancel self-timer recording

Press  so that the  indicator disappears from the LCD screen or in the viewfinder while the camcorder is in Standby mode.

Self-timer recording mode is canceled when

- Self-timer recording is finished.
- The POWER switch is set to OFF or VTR.

Note

The display may become darker right after pressing the  button. This is not a malfunction.

Hints for better shooting

For hand-held shots, you will get better results by holding the camcorder according to the following suggestions:

- Hold the camcorder firmly and secure it with the grip strap so that you can easily manipulate the controls with your thumb. [a]

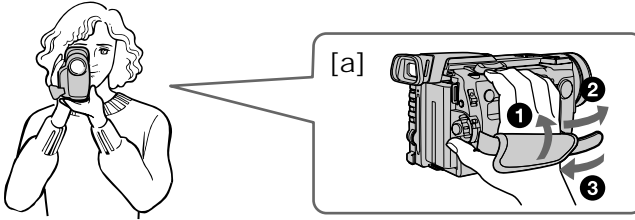

- Place your elbows against your side.
- Place your left hand under the camcorder to support it.
- Place your eye against the viewfinder eyecup.
- Be sure not to touch the built-in microphone.
- Use the LCD panel frame or the viewfinder frame as a guide to determine the horizontal plane.
- You can also record in a low position to get an interesting angle. Lift the viewfinder up for record from a low position. [b]
- You can also record in a low position or even in a high position using the LCD panel. [c]
- When you use the LCD screen outdoors in direct sunlight, the LCD screen may be difficult to see. If this happens, we recommend that you use the viewfinder.

[b]



[c]



Hints for better shooting

Place the camcorder on a flat surface or use a tripod

Try placing the camcorder on a table top or any other flat surface of suitable height. If you have a tripod for a still camera, you can also use it with the camcorder. When attaching a non-Sony tripod, make sure that the length of the tripod screw is less than 6.5 mm. Otherwise, you cannot attach the tripod securely and the screw may damage the camcorder.

Cautions on the LCD panel and on the viewfinder

- Do not pick up the camcorder by the viewfinder or the LCD panel. [d]
- Do not place the camcorder so as to point the viewfinder or the LCD panel toward the sun. The inside of the viewfinder or the LCD panel may be damaged. Be careful when placing the camcorder under sunlight or by a window. [e]

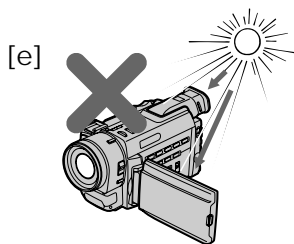
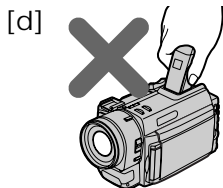

Checking the recorded picture

Using the EDITSEARCH, you can review the last recorded scene or check the recorded picture on the LCD screen or in the viewfinder.

- (1) While pressing the small green button on the POWER switch, set it to CAMERA.
- (2) Press the - side of EDITSEARCH momentarily; the last few seconds of the recorded portion plays back (Rec Review). Hold down the - side of EDITSEARCH until the camcorder goes back to the scene you want. The last recorded portion is played back. To go forward, hold down the + side (Edit Search).

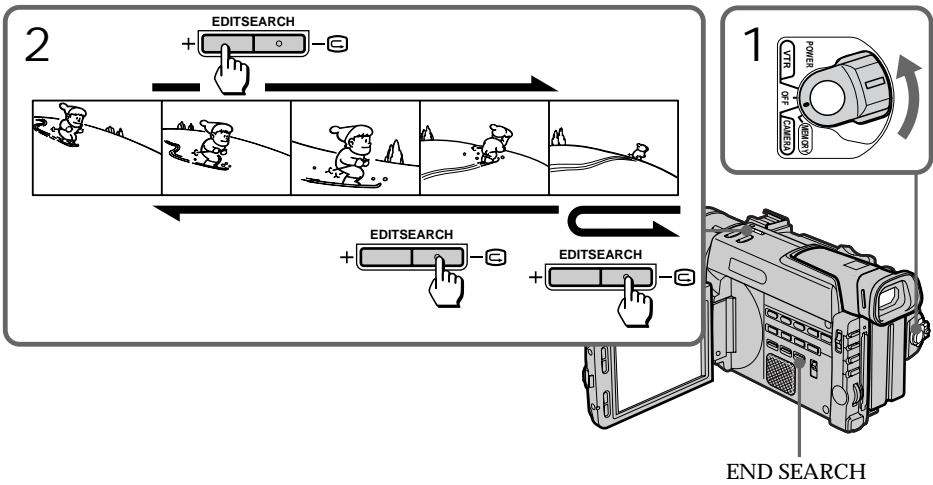

To stop playback
Release EDITSEARCH.

To go back to the last recorded point (END SEARCH)
Press END SEARCH. The last recorded point is played back for about 5 seconds and stops.
Note that when you use a tape without cassette memory, this function does not work once you eject the cassette after recording.

To begin re-recording
Press START/STOP. Re-recording begins from the point you released EDITSEARCH.
Provided you do not eject the tape, the transition between the last scene you recorded and the next scene you record will be smooth.

Playing back a tape

You can monitor the playback picture on the LCD screen or in the viewfinder.

- (1) Insert the recorded tape with the window facing out.
- (2) While pressing OPEN, open the LCD panel.
- (3) While pressing the small green button on the POWER switch, set it to VTR.
- (4) Press ◀◀ to rewind the tape.
- (5) Press ▶▶ to start playback.

Adjust the volume using VOLUME +/- and the brightness of the LCD screen using LCD BRIGHT +/-.

You can also monitor the picture on a TV screen, after connecting the camcorder to a TV or VCR.

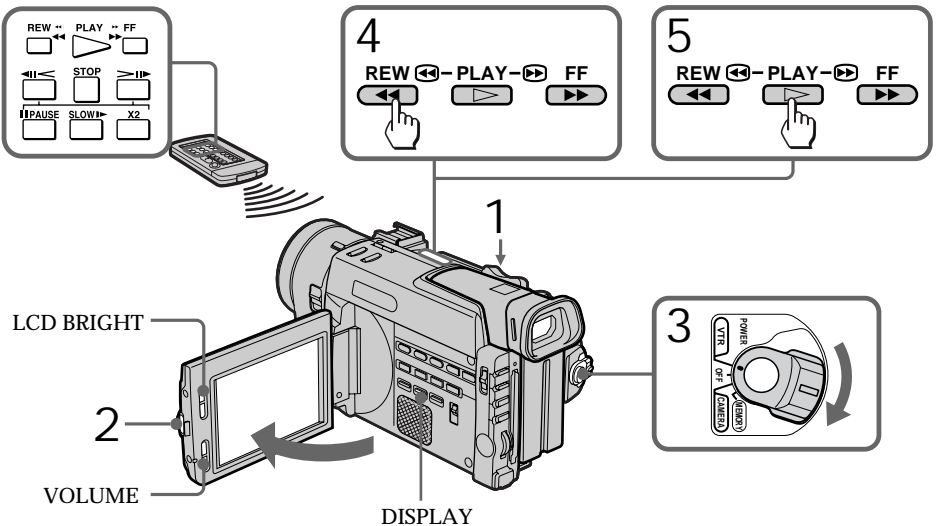

- To stop playback, press □.
- To rewind the tape, press ◀◀.
- To fast-forward the tape rapidly, press ▶▶.

Using the Remote Commander

You can control playback using the supplied Remote Commander. Before using the Remote Commander, insert the R6 (size AA) batteries.

To display the LCD screen/viewfinder screen indicators

Press DISPLAY.

To erase the indicators, press again.

Notes on screen indicators

- The screen indicator disappears when the title is displayed.
- When you play back a tape using a "InfoLITHIUM" battery,  indicates the remaining battery capacity. The remaining battery time in minutes is not displayed.

Using headphones

Connect headphones (not supplied) to the  jack. You can adjust the volume of the headphones using VOLUME +/-.

To view the playback picture in the viewfinder
Close the LCD panel. The viewfinder turns on automatically.
When using the viewfinder, you can monitor the sound only by using headphones.
To view on the LCD screen again, open the LCD panel. The viewfinder turns off automatically.

When you cannot see the LCD screen clearly
Pull out the stand at the bottom to adjust the angle.



Various playback modes

To view a still picture (playback pause)
Press **II** during playback. To resume playback, press **II** or **▷**.

To locate a scene (picture search)
Keep pressing **◀◀** or **▶▶** during playback. To resume normal playback, release the button.

To monitor the high-speed picture while advancing the tape or rewinding (skip scan)
Keep pressing **◀◀** while rewinding or **▶▶** while advancing the tape. To resume normal rewinding or fast-forward, release the button.

To view the picture at 1/3 speed (slow playback)
Press **▶** on the Remote Commander during playback. For slow playback in reverse direction, press **<**, then press **▶**. To resume normal playback, press **▷**.

To view the picture at double speed
For double speed playback in the reverse direction, press **<**, then press **×2** on the Remote Commander during playback. For double speed playback in the forward direction, press **>**, then press **×2** during playback. To resume normal playback, press **▷**.

To view the picture frame-by-frame
Press **◀II** or **II▶** on the Remote Commander in playback pause mode. If you keep pressing the button, you can view the picture at 1/30 speed. To resume normal playback, press **▷**.

To change the playback direction
Press **<** on the Remote Commander for reverse direction or **>** on the Remote Commander for forward direction during playback. To resume normal playback, press **▷**.

Notes on playback

- The sound is muted in the various playback modes.
- During playback other than normal playback, the previous recording may appear in mosaic image. This is not malfunction.
- When playback pause mode lasts for 5 minutes, the camcorder automatically enters stop mode. To resume playback, press **▷**.

Note on slow playback

The slow playback can be performed smoothly on this camcorder; however, this function does not work for an output signal from the **DV IN/OUT** jack.

Searching for the end of the picture

You can go to the end of the recorded portion after you record and play back the tape. The tape starts rewinding or fast-forwarding and the last about 5 seconds of the recorded portion plays back. Then the tape stops at the end of the recorded picture (End Search).

Open the LCD panel and press END SEARCH during recording standby. This function works when the POWER switch is set to CAMERA or VTR.

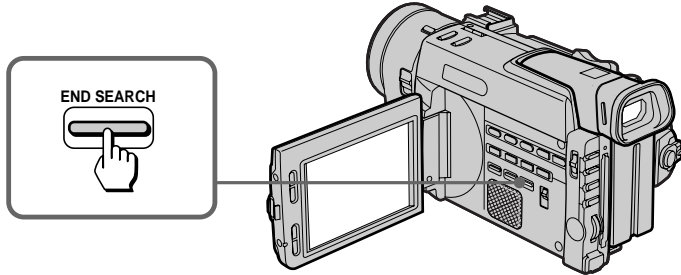

Notes on End Search

- When you use a tape without cassette memory, the End Search function does not work once you eject the cassette after recording.
- When you use a tape with cassette memory, the End Search function works once you eject the cassette. When you play back a tape which has a blank portion in the beginning or between the recorded portions, the End Search function will not work correctly.

Using alternative power sources

You can choose any of the following power sources for your camcorder: battery pack, house current, and 12/24 V car battery. Choose the appropriate power source depending on where you want to use your camcorder.

Place	Power source	Accessory to be used
Indoors	House current	Supplied AC power adaptor
Outdoors	Battery pack	Battery pack NP-F330 (supplied), NP-F530, NP-F550, NP-F730, NP-F750, NP-F930, NP-F950
In the car	12 V or 24 V car battery	Sony DC adaptor/charger DC-V700

Note on power sources

Disconnecting the power source or removing the battery pack during recording or playback may damage the inserted tape. If this happens, restore the power supply again immediately.

Using the house current

To use the supplied AC power adaptor:

- (1) Open the DC IN jack cover, and connect the AC power adaptor to the DC IN jack on the camcorder.
- (2) Connect the power cord to the AC power adaptor.
- (3) Connect the power cord to a wall outlet.

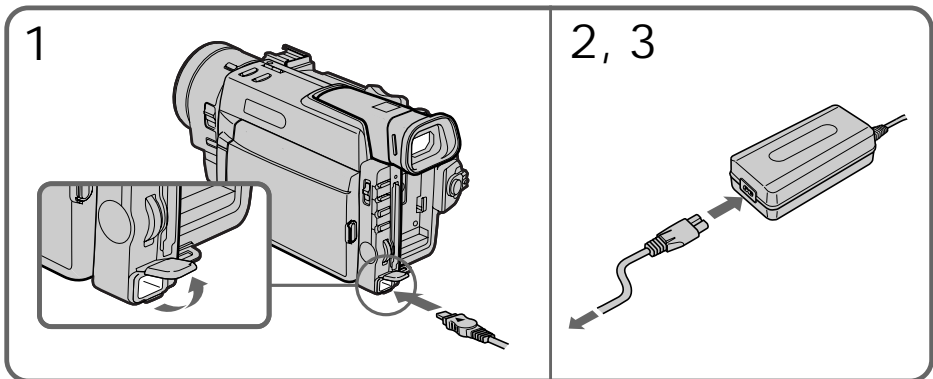

WARNING

The power cord must be changed only at a qualified service shop.

PRECAUTION

The set is not disconnected from the AC power source (house current) as long as it is connected to the power cord, even if the set itself has been turned off.

Note

Keep the AC power adaptor away from the camcorder if the picture is disturbed.

Using a car battery

Use a DC adaptor/charger such as Sony DC-V700 (not supplied). Connect the car battery cord to the cigarette lighter socket of a car (12 V or 24 V). Connect the DC adaptor/charger and the camcorder using the DK-415 (supplied with DC-V700) connecting cord.



This mark indicates that this product is a genuine accessory for Sony video product.

When purchasing Sony video products, Sony recommends that you purchase accessories with this "GENUINE VIDEO ACCESSORIES" mark.

Changing the mode settings

You can change some of the mode settings programmed at the factory to further enjoy the features and functions of the camcorder. Just turn the control dial to select the menu items displayed on the LCD screen. You can make selections in the following order: the menu display → icons → items → mode settings.

- (1) Press MENU to display the menu.
- (2) Turn the control dial to select the desired icon on the left side of the menu, then press the dial.
- (3) Turn the control dial to select the desired item, then press the dial.
- (4) Turn the control dial to select the desired mode, then press the dial. If you want to change the other modes, repeat steps 3 and 4. If you want to change the other items, select ↶ RETURN and press the dial, then repeat steps 2 to 4.
- (5) Press MENU to erase the menu display.

1

CAMERA	VTR
MANUAL SET AUTO SHTR PROG. SCAN [MENU] : END	VTR SET HI FI SOUND AUDIO MIX [MENU] : END
MEMORY	
MANUAL SET AUTO SHTR [MENU] : END	

2

VTR SET	HI FI SOUND	AUDIO MIX
[MENU] : END	[MENU] : END	[MENU] : END
SETUP MENU AUTO TV ON TV INPUT LTR SIZE [MENU] : END		
SETUP MENU AUTO TV ON OFF TV INPUT LTR SIZE RETURN [MENU] : END		

3

SETUP MENU	AUTO TV ON OFF	TV INPUT	LTR SIZE
[MENU] : END	[MENU] : END	[MENU] : END	[MENU] : END
SETUP MENU AUTO TV ON TV INPUT VIDEO1 LTR SIZE RETURN [MENU] : END			
SETUP MENU AUTO TV ON VIDEO1 TV INPUT VIDEO1 LTR SIZE VIDEO2 RETURN VIDEO3 OFF [MENU] : END			

4

SETUP MENU	AUTO TV ON	TV INPUT VIDEO1	LTR SIZE VIDEO2
[MENU] : END	[MENU] : END	[MENU] : END	[MENU] : END
SETUP MENU AUTO TV ON VIDEO1 TV INPUT VIDEO2 LTR SIZE VIDEO3 RETURN OFF [MENU] : END			
SETUP MENU AUTO TV ON VIDEO2 TV INPUT VIDEO2 LTR SIZE RETURN [MENU] : END			

5

MENU

Notes on changing the mode settings

- Menu items differ depending on the setting of the POWER switch to VTR, CAMERA or MEMORY.
- While recording in mirror mode, you cannot operate the menu system.

Selecting the mode setting of each item

Menu items that can be modified differ depending on the setting of the POWER switch. The LCD screen shows only the items that you can operate at the moment. The menu items are categorized into nine groups signified by the nine icons described below.

Items for the MANUAL SET menu

AUTO SHTR <ON/OFF>

- Select ON and the electronic shutter functions automatically when shooting in bright conditions.
- Select OFF and the electronic shutter does not function even in bright conditions.

PROG. SCAN* <OFF/ON>

- Select OFF not to record still/moving pictures with all the pixels.
- Select ON to record still/moving pictures with all the pixels.

Items for the CAMERA SET menu

D ZOOM <OFF/ON>

- Select OFF not to use the digital zoom. The camcorder goes back to 12x optical zoom.
- Select ON to activate digital zooming.

16:9WIDE <OFF/ON>

Select this item to record a 16:9 wide picture. See page 39 for details.

STEADYSHOT <ON/OFF>

- Normally select ON.
- Select OFF when you do not have to worry about camera-shake.

AE SHIFT

Adjust the setting level of AE (Automatic Exposure). See page 52 for details.

GAIN SHIFT <0dB/-3dB>

- Set the gain value to 0dB.
- Set the gain value to -3dB.

FRAME REC <OFF/ON>

- Normally select OFF.
- Select ON for cut recording. See page 61 for details.

When you remove the power source, the setting becomes OFF.

INT.REC <ON/OFF/SET> <INTERVAL/REC TIME>

- Normally select OFF. Select ON to make an interval recording.
- Select INTERVAL to set or change the waiting time for interval recording.
- Select REC TIME to set or change the recording time for interval recording.

When you remove the power source, the setting becomes OFF, but the waiting time and recording time are retained.

Items for the VTR SET menu

HIFI SOUND* <STEREO/1/2>

- Select STEREO to play back stereo sound or main and sub sound (for dual sound).
- Select 1 to play back the left sound (for stereo sound) or main sound (for dual sound).
- Select 2 to play back the right sound (for stereo sound) or sub sound (for dual sound).

AUDIO MIX*

Select this item to adjust the balance between the stereo 1 and stereo 2 by turning the control dial.

Items for the LCD/VF SET menu

LCD B.L. <BRT NORMAL/BRIGHT>

- Normally select BRT NORMAL.
- Select BRIGHT when the LCD screen is dark. The battery consumption increases by 10 to 20%.

Even if you adjust the LCD B.L., the recorded picture is not affected.

LCD COLOR

Select this item and change the level of the indicator by turning the control dial up (+) or down (-) to adjust the color intensity of the picture.

VF BRIGHT

Close the LCD panel.

Select this item to adjust the brightness of the viewfinder. The viewfinder becomes brighter when you turn the control dial up (+), and darker when you turn it down (-).

ZEBRA <OFF/ON>

- Normally select OFF.
- Select ON to shoot with the zebra pattern displayed on the LCD screen or in the viewfinder.

Items for the MEMORY SET menu

CONTINUOUS <OFF/ON/MULTI SCRΝ>

- Select OFF not to record continuously.
- Select ON to record 2 to 4 pictures continuously.
- Select MULTI SCRΝ to record nine pictures continuously.

QUALITY <STANDARD/FINE/SUPER FINE>

- Select STANDARD to record still pictures in the standard image quality mode, using the memory card slot.
- Select FINE to record still pictures in the fine image quality mode, using the memory card slot.
- Select SUPER FINE to record still pictures in the superfine image quality mode, using the memory card slot.

PROTECT <OFF/ON>

- Normally select OFF not to protect still pictures.
- Select ON to protect selected still pictures against accidental erasure. See page 108 for details.

SLIDE SHOW

Select this item to play back images in a continuous loop. See page 114 for details.

DELETE ALL

Select this item to delete all the images. See page 109 for details.

FORMAT

Select this item to format floppy disks or PC cards. See page 96 for details.

PHOTO SAVE

Select this item to duplicate still pictures. See page 100 for details.

Items for the CM SET menu

CM SEARCH <ON/OFF>

- Select ON to search using cassette memory.
- Select OFF to search without using cassette memory.

TITLEERASE

Erase the title you have superimposed.

TITLE DSPL <ON/OFF>

- Select ON to display the title you have superimposed.
- Select OFF not to display the title.

TAPE TITLE

Select this item to label the cassette tape.

ERASE ALL

Select this item to erase all the data in cassette memory.

Items for the TAPE SET menu

REC MODE <SP/LP>

- Select SP when recording in SP (standard play) mode.
- Select LP when recording in LP (long play) mode.

AUDIO MODE <12BIT/16BIT>

- Normally select 12BIT to record two stereo sounds.
- Select 16BIT to record the one stereo sound with high quality.

MIC LEVEL * <AUTO/MANUAL>

- Select AUTO to adjust the recording level automatically.
- Select MANUAL to adjust the recording level manually.

REMAIN <AUTO/ON>

- Select AUTO to display the remaining time of the tape in the following cases:
 - With the power on or a tape inside, for eight seconds after the remaining time of the tape becomes certain.
 - For eight seconds after the  or DISPLAY button is pressed.
 - During rewinding, fast-forwarding, and searching the picture.
- Select ON to always display the remaining time of the tape.

DATA CODE <DATE/CAM or DATE>

- Select DATE/CAM to display date and recording data during playback.
- Select DATE to display date during playback.

Items for the SETUP menu

CLOCK SET

Select this item to reset the date or time.

AUTO TV ON <OFF/ON>

You can use this feature only with Sony TVs.

- Select OFF not to turn on the TV.
- Select ON to turn on the TV automatically when using the LASER LINK function.

TV INPUT <VIDEO1/VIDEO2/VIDEO3/OFF>

Select 1, 2 or 3 of the video input on the TV which the AV cordless IR receiver (not supplied) is connected to when using the LASER LINK function.

LTR SIZE <NORMAL/2X>

- Normally select NORMAL.
- Select 2X to display the selected menu item by twice size of the normal.

DEMO MODE <ON/OFF>

- Select ON to glance over the function of camcorder.
- Select OFF not to display demonstration.

Notes on DEMO MODE

- DEMO MODE is set to STBY (Standby) at the factory. The demonstration starts about 10 minutes after you set the POWER switch to CAMERA without inserting a cassette. You can cancel the demonstration by inserting a cassette, setting the POWER switch to a position other than CAMERA, or select OFF in the menu system. To select STBY again, set the POWER switch to OFF when DEMO MODE is set to ON, and set the POWER switch back to CAMERA.
- You cannot select DEMO MODE when a cassette is inserted in the camcorder.
- If you insert a cassette during the demonstration, the demonstration stops. You can start recording as usual. DEMO MODE automatically returns to STBY.
- To look at the demonstration at once, eject the cassette, if inserted. Then select ON of DEMO MODE and erase the menu display. The demonstration will begin.

Items for the  OTHERS menu

WORLD TIME

Select this item to set the clock by a time difference. See page 119 for details.

BEEP <MELODY/NORMAL/OFF>

- Normally select MELODY so that a melody sounds when you start/stop recording, etc.
- Select NORMAL so that beeps sound when you start/stop recording, etc.
- Select OFF when you do not want to hear the beep sound.

COMMANDER* <ON/OFF>

- Select ON when using the supplied Remote Commander for the camcorder.
- Select OFF when not using the Remote Commander.

DISPLAY <LCD or V-OUT/LCD >

- Normally select LCD.
- Select V-OUT/LCD to display indicators both on the LCD screen and TV screen.

REC LAMP <ON/OFF>

- Normally select ON.
- Select OFF when you do not want the camera recording lamp on the front of the unit to light up.

COLOR BAR <OFF/ON>

- Normally select OFF not to display the color bar.
- Select ON to display the color bar.

DV EDITING

Select this item when editing a tape on another equipment connected with the i.LINK cable (DV connecting cable). See page 84 for details.

* These settings return to the default 5 minutes or more after the power source is disconnected or battery is removed. As far as the other items without an asterisk are concerned, their settings are retained even when the power source is disconnected or battery is removed, as long as the vanadium-lithium battery is charged.

When recording a close subject

When REC LAMP is set to ON, the red camera recording lamp on the front of the camcorder may reflect on the subject if it is close. In this case, we recommend you set REC LAMP to OFF.

Notes

- When playing back a tape recorded in the 16-bit mode, you cannot adjust the balance in AUDIO MIX.
- If you select 16BIT in AUDIO MODE, you cannot add an audio sound.
- If you select BRIGHT in LCD B.L., the battery life while recording decreases 10 to 20%. When you use a power source other than the battery, the menu item LCD B.L. is set to BRIGHT automatically and the item does not appear on the screen.

Photo recording

You can record a still picture like a photograph for about seven seconds. This photo recording is useful when you want to enjoy a picture such as a photograph or when you print a picture using a video printer (not supplied). You can record about 510 pictures on a 60-minute tape in SP mode.

Besides the operation described here, this camcorder can record a still picture on a PC card (not supplied), using the memory card slot (see page 102).

You can also record still/moving pictures on a mini DV tape with all the pixels in the progressive mode. See page 35 for details.

- (1) While pressing the small green button on the POWER switch, set it to CAMERA.
- (2) Keep pressing PHOTO lightly until a still picture and "CAPTURE" appears on the LCD screen or in the viewfinder.

Recording does not start yet. To change the still picture, release PHOTO, select still picture again, and keep pressing PHOTO lightly again.

If you press PHOTO on the Remote Commander when a still picture appears on the LCD screen or in the viewfinder, the camcorder will record that still picture. However, you cannot select other still pictures by using this button.

- (3) Press PHOTO deeper.

The still picture on the LCD screen or in the viewfinder is recorded for about seven seconds. The sound during those seven seconds is also recorded.

To record a still picture while normal recording, press PHOTO deeper. Then the still picture is recorded for about seven seconds and the camcorder returns to Standby mode.

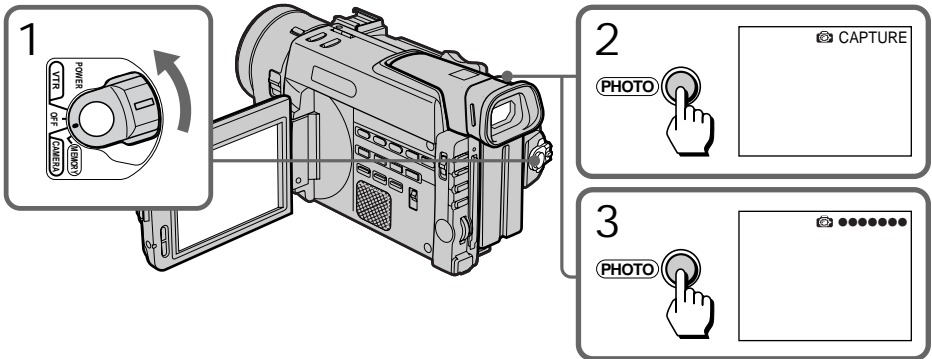

When shooting in the dark

Install the HVL-FDH2 video flash light (not supplied) to the accessory shoe. If the exposure is in manual exposure mode, set it to automatic exposure mode.

When ⚡ appears next to the "CAPTURE" indicator on the LCD screen or in the viewfinder, the video flash is ready to be used.

Note on the still picture

When the still picture recorded on this camcorder is played back on another VCR, the picture may be blurred. This is not a malfunction.

When you press PHOTO while recording a photo

The picture on the LCD screen or in the viewfinder whenever you press PHOTO will be recorded. You cannot check the recorded picture by pressing PHOTO lightly.

After the moving picture is recorded as a still picture for about seven seconds, the camcorder will go back to Standby mode.

Printing the still picture

You can print a still picture by using the video printer (not supplied). Connect the video printer using the S video connecting cable (not supplied). Refer to the operating instruction of the video printer as well.

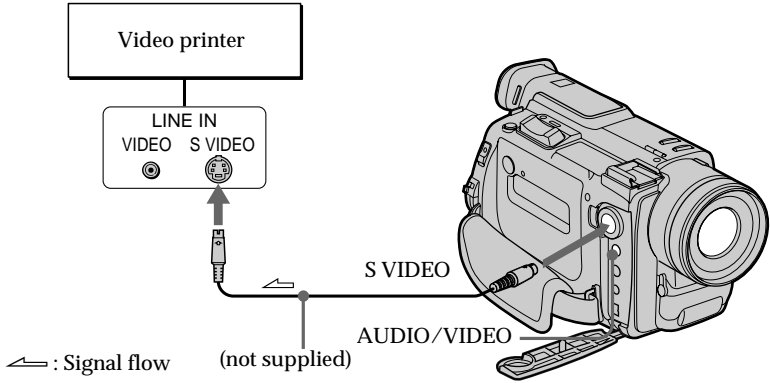

If the video printer is not equipped with S VIDEO input
Use the supplied A/V connecting cable. Connect it to the AUDIO/VIDEO jack and connect the yellow plug of the cable to the VIDEO input of the video printer.

Shooting with all the pixels – PROG. SCAN

When modifying the digital images on your personal computer, set PROG. SCAN to ON before shooting. You can record the images on a mini DV tape frame by frame with higher resolution.

Since the image taken in progressive mode does not go out of focus even in a pause, it is especially useful when you analyze high-speed actions such as sport scenes.



- (1) Press MENU to display the menu in Standby mode.
- (2) Turn the control dial to select **MANU**, then press the dial.
- (3) Turn the control dial to select PROG. SCAN, then press the dial.
- (4) Turn the control dial to select ON, then press the dial.
- (5) Press MENU to erase the menu display. The PROG. SCAN indicator lights up.

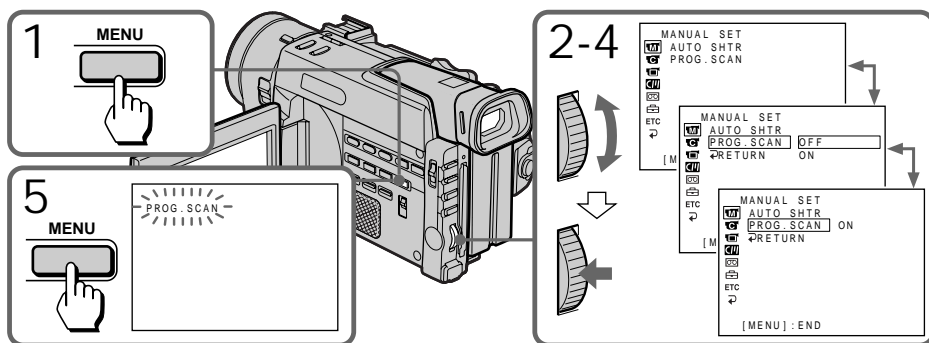

To return to normal mode
Select OFF in step 4, then press the control dial.

Note on the progressive mode

The normal TV broadcast divides the screen into two finer fields and displays them in turns every 1/60 of a second. Thus, the actual image displayed in an instant covers only half of the apparent image area. Displaying the whole image simultaneously on a full screen is called displaying with all the pixels. In this mode the picture is clearer than one in normal mode, but moving objects appear jerky since the picture is read/output every about 1/15 second.

The setting at the factory

This camcorder is originally programmed to record still/moving pictures on a mini DV tape in the normal TV format (Interlace format).

When shooting under fluorescent light

When shooting in the progressive mode under fluorescent light or light bulb, a rare phenomenon may happen in which the screen lights up brightly (Flicker phenomenon). This is not a malfunction. If you want to stop this phenomenon, set PROG. SCAN to OFF in the menu system.

Using the FADER function

You can fade in or out to give your recording a professional appearance.

When fading in, the picture gradually fades in while the sound increases. When fading out, the picture gradually fades out while the sound decreases.

FADER

[a] **STBY** **REC**



OVERLAP (FADE IN only)



[b] **STBY** **REC**

MONOTONE

When fading in, the picture gradually changes from black and white to color.

When fading out, the picture gradually changes from color to black and white.

When fading in [a]

- (1) While the camcorder is in Standby mode, press FADER until the desired indicator flashes.
- (2) Press START/STOP to start recording. The fade indicator stops flashing.

When fading out [b]

- (1) During recording, press FADER until the desired indicator flashes.
- (2) Press START/STOP to stop recording. The fade indicator stops flashing, and then recording stops.

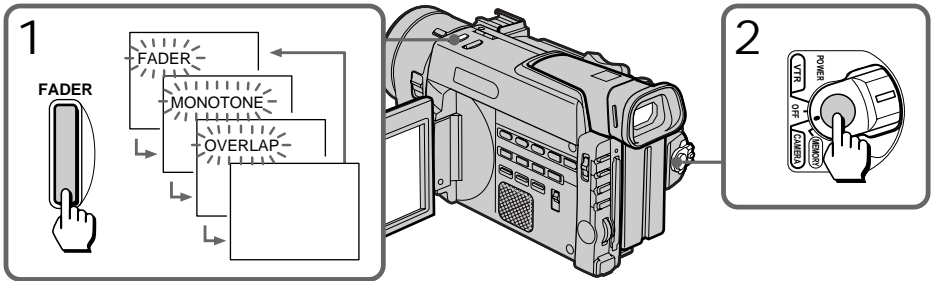

To cancel the fader function

Before pressing START/STOP, press FADER until the fade indicator disappears.

You cannot use the fader function in the following situations

- The START/STOP MODE selector is set to \triangle ANTI GROUND SHOOTING or 5SEC.
- The camcorder is in the photo recording.
- A title is displayed on the LCD screen or in the viewfinder. If the title is not necessary, erase it before using the fader function.

Note

During fading, you cannot operate the DIGITAL EFFECT button.

The fader function is effective in the following situations

- A big change of scene (FADE IN, FADE OUT)
- The beginning of a story (FADE IN)
- The end of a day (FADE OUT)
- Change the scene while leaving the trace of the previous scene

If you use the fader function repeatedly

The situation the subject is in cannot be seen clearly, thus making the picture difficult to enjoy.

When the OVERLAP indicator appears

The camcorder automatically memorizes the image recorded on a tape. As the image is being memorized, the OVERLAP indicator flashes fast, and the playback picture is displayed. At this stage, the picture may not be recorded clearly, depending on the tape condition.

Shooting with backlighting

When you shoot a subject with the light source behind the subject or a subject with a light background, use the BACK LIGHT function.

Press BACK LIGHT. The  indicator appears on the LCD screen or in the viewfinder.

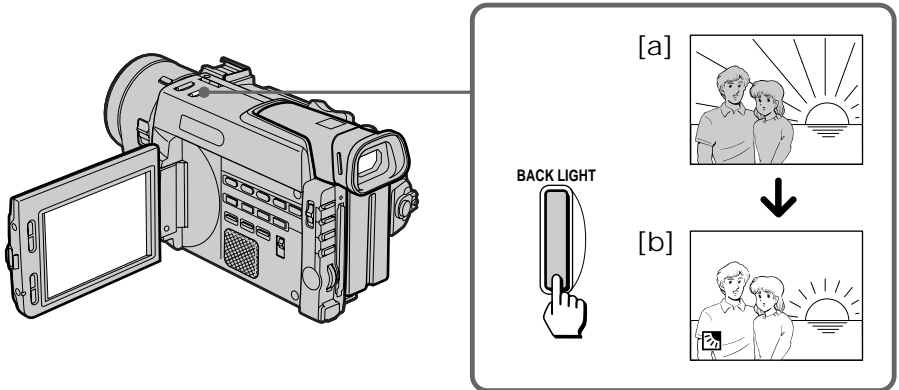

[a] Subject is too dark because of backlight.

[b] Subject becomes bright with backlight compensation.

After shooting

Be sure to release this adjustment condition by pressing BACK LIGHT again. The  indicator disappears. Otherwise, the picture will be too bright under normal lighting condition.

This function is also effective under the following conditions:

- A subject with a light source nearby or a mirror reflecting light.
- A white subject against a white background. Especially when you shoot a person wearing shiny clothes made of silk or synthetic fiber, his or her face tends to become dark if you do not use this function.

Note on the BACK LIGHT function

When you press EXPOSURE or SHUTTER SPEED, the BACK LIGHT function is canceled.

Using the wide mode function

You can record a 16:9 wide picture to watch on the 16:9 wide-screen TV (16:9WIDE). The picture with black bands at the top and the bottom on the LCD screen or in the viewfinder [a] is normal. The picture on a normal TV [b] is horizontally compressed. You can watch the picture of normal images on a wide-screen TV [c].

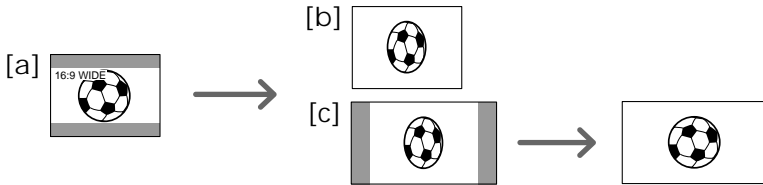

- (1) Set the POWER switch to CAMERA.
- (2) Press MENU to display the menu.
- (3) Turn the control dial to select  then press the dial.
- (4) Turn the control dial to select 16:9WIDE, then press the dial.
- (5) Turn the control dial to select ON, then press the dial.
- (6) Press MENU to erase the menu display.

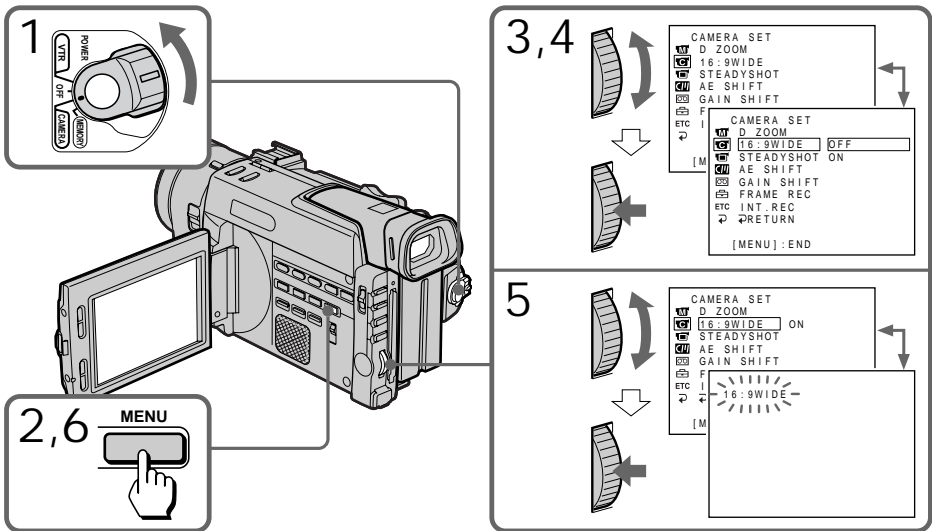

To cancel wide mode
Select OFF in step 5, then press the control dial.

To watch the tape recorded in wide mode
To watch the tape recorded in 16:9WIDE mode, set it to full mode. For details, refer to the operating instruction of your TV.
Note that the picture recorded in 16:9WIDE mode looks compressed on a normal TV.

Notes on wide mode

- In wide mode, you cannot select the old movie function with DIGITAL EFFECT.
- You cannot select or cancel the wide mode during recording.
- You cannot use the wide mode function when you set PROG. SCAN to ON.

Enjoying picture effect

Selecting picture effect

You can make pictures like those of television with the Picture Effect function.

[a]



[b]



[c]



[d]



NEG. ART [a]

The color of the picture is reversed.

SEPIA

The picture is sepia.

B&W

The picture is monochrome (black and white).

SOLARIZE [b]

The light intensity is clearer, and the picture looks like an illustration.

SLIM [c]

The picture expands vertically.

STRETCH [d]

The picture expands horizontally.

Using picture effect function

- (1) While in Standby mode, press PICTURE EFFECT.
- (2) Turn the control dial to select the desired picture effect mode.

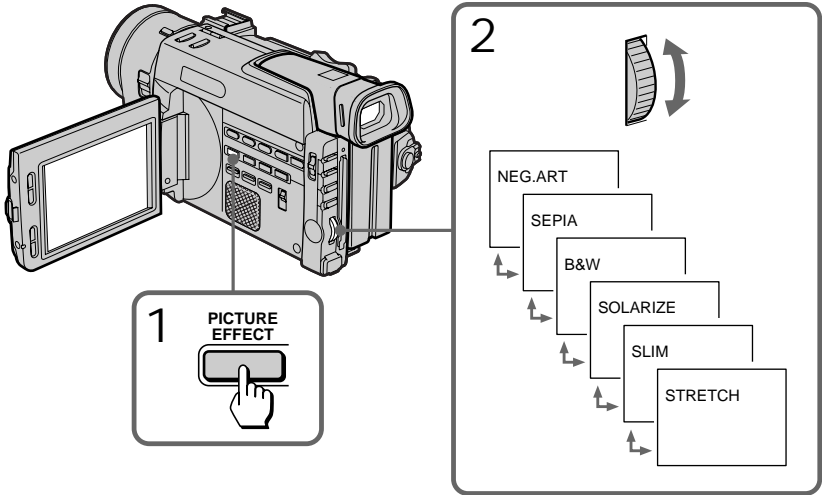

To return to normal mode

Press PICTURE EFFECT so that the indicator disappears.

Notes on the picture effect

- When you turn the power off, the camcorder returns automatically to normal mode.
- You cannot select SLIM and STRETCH when you set PROG. SCAN to ON.
- While using the picture effect function, you cannot select the old movie function with DIGITAL EFFECT.

Recording with various effects – digital effect

With the following functions of Digital Effect, you can add various visual effects to the picture. The sound is recorded normally.

STILL

You can record a still picture to be superimposed on a moving picture.



FLASH

You can record still pictures successively at constant intervals.

LUMI.

You can replace a brighter portion of a still picture with a moving picture.



TRAIL

You can record the picture which leaves an incidental image, such as a trail.

OLD MOVIE

You can record the picture such as an old movie. The camcorder automatically sets the wide mode to 16:9WIDE, picture effect to SEPIA, and the appropriate shutter speed.

- (1) While in Standby mode or Recording mode, press DIGITAL EFFECT.
The digital effect indicator flashes.
- (2) Turn the control dial to select the desired digital effect mode.
- (3) Press the control dial. The digital effect indicator lights up and the bars appear. The bar does not appear in the OLD MOVIE mode. The still picture is stored in memory in the STILL or LUMI. mode.
- (4) Turn the control dial to adjust effects.
The longer the bar is, the greater the effects are.
STILL : The proportion of still picture to moving picture.
FLASH : The length of the intervals.
LUMI. : The brightness of the area where you paste the moving picture.
TRAIL : The length of time the incidental image remains.
OLD MOVIE : No adjustment necessary.

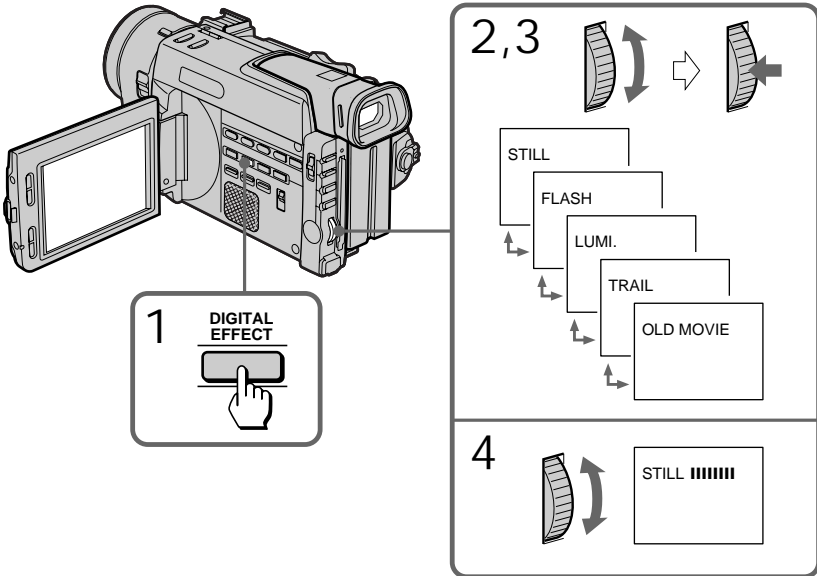

To cancel digital effects

Press **DIGITAL EFFECT** so that the indicator disappears.

Notes on digital effect

- You cannot use the following functions while using the digital effect.
 - Functions using the **FADER** button
 - Functions using the **PHOTO** button
- When you set the **POWER** switch to **OFF**, the digital effect will be canceled automatically.

Notes on the OLD MOVIE mode

You cannot use the following functions in the **OLD MOVIE** mode.

- Functions using the **PROGRAM AE** button
- **16:9WIDE** mode
- Functions using the **PICTURE EFFECT** button

Shooting with manual adjustment

Under normal conditions, this unit automatically makes various adjustments as it shoots. However, you can adjust manually the following functions to your preference.

Functions you can adjust by setting the AUTO LOCK selector to the center (auto lock release) position

Brightness (exposure), shutter speed, white balance, and program AE

Functions you can adjust by setting MENU

Zebra pattern, recording level, deactivating the Steady Shot, gain shift, and AE shift

Functions you can adjust by using other buttons/switches

ND filter, focus

The following describes how to adjust all the functions mentioned above except program AE (see page 54) and focus (see page 57).

AUTO LOCK selector

Set the selector as shown below to maintain or release the settings of the functions.

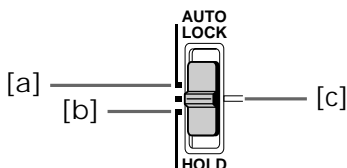

AUTO LOCK [a]

Select this position to let the unit adjust all the functions automatically.

HOLD [b]

Select this position after setting the functions manually to maintain the settings.

Manual position [c]

Select this position to adjust manually the functions listed above.

Adjusting exposure

Adjust the exposure manually under the following cases.

[a]



[b]



[a]

- The background is too bright (back lighting)
- Insufficient light: most of the picture is dark

[b]

- Bright subject and dark background
- To record the darkness faithfully

- (1) Set AUTO LOCK selector to the center (auto lock release) position while the camcorder is in Standby mode.
- (2) Press EXPOSURE. The exposure indicator appears on the LCD screen or in the viewfinder.
- (3) Turn the control dial to adjust the exposure.

Shooting with manual adjustment

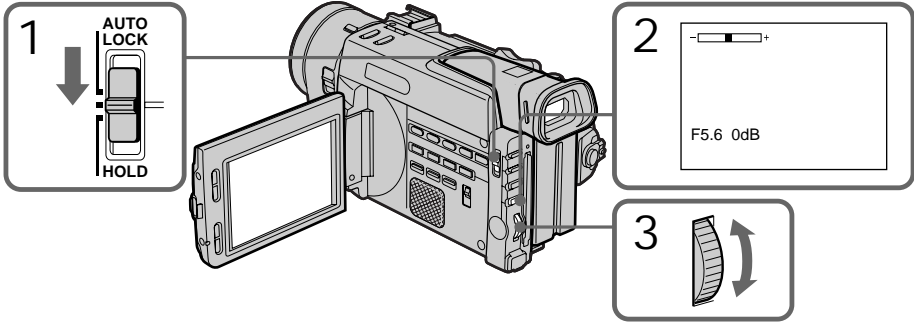

To return to automatic exposure mode

Set AUTO LOCK selector to AUTO LOCK or press EXPOSURE to turn off the exposure indicator.

Notes

- The control dial does not have a stop position.
- If you press PROGRAM AE, the exposure comes back to automatic adjustment again.
- When you adjust the exposure manually, you cannot use the BACK LIGHT function.

Adjusting the shutter speed

- (1) Set AUTO LOCK selector to the center (auto lock release) position while the camcorder is in Standby mode.
- (2) Press SHUTTER SPEED. The shutter speed indicator appears on the LCD screen or in the viewfinder.
- (3) Turn the control dial to select the desired speed. The available shutter speed ranges from 1/4 to 1/10000.

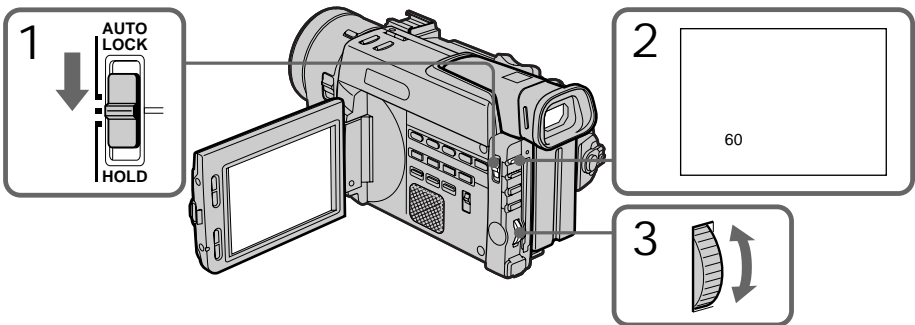

To return to automatic shutter speed mode

Set AUTO LOCK selector to AUTO LOCK or press SHUTTER SPEED to turn off the shutter speed indicator.

When shooting at slow shutter speed



At slow shutter speed, automatic focus may be lost. Adjust focus manually using a tripod.

Adjusting the white balance

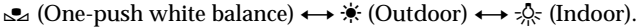
White balance adjustment makes white subjects look white and allows more natural color balance for camera recording. Normally white balance is automatically adjusted. You can obtain better results by adjusting the white balance manually when lighting conditions change quickly or when recording outdoors: e.g., neon signs, fireworks.

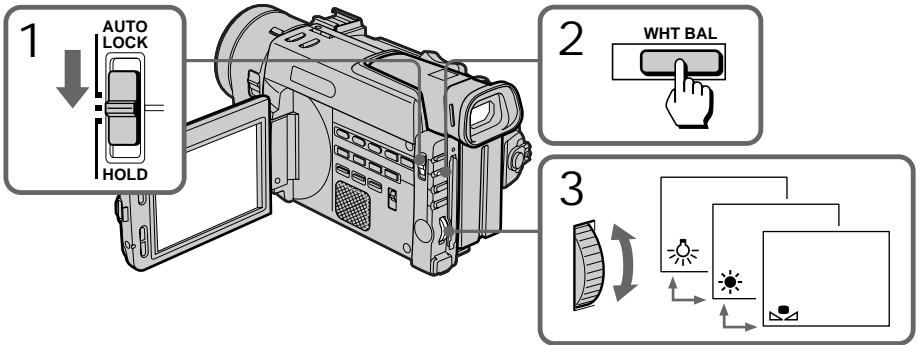
- (1) Set AUTO LOCK selector to the center (auto lock release) position while the camcorder is in Standby mode.
- (2) Press WHT BAL. The white balance indicator appears on the LCD screen or in the viewfinder.
- (3) Turn the control dial to select the appropriate white balance mode under the following conditions. As you turn the dial, the display changes as follows:



Display	Shooting conditions
	<ul style="list-style-type: none"> • Adjust the white balance according to the light source. This operation is not available during recording. Follow the steps described on the next page to adjust the settings again.
 (Outdoor)	<ul style="list-style-type: none"> • Recording a sunset/sunrise, just after sunset, just before sunrise, neon signs, or fireworks • Under a color matching fluorescent lamp
 (Indoor)	<ul style="list-style-type: none"> • Lighting condition changes quickly • Too bright place such as photography studios • Under sodium lamps or mercury lamps

If you have selected  in step 3

When you set the white balance to one-push white balance mode, the setting is locked and maintained even if lighting conditions change. You can achieve recording with natural colors without being affected by ambient light.

(With the  indicator on the screen)

(1) Shoot a white object such as paper fully on the LCD screen or in the viewfinder.

(2) Press the control dial.

The  indicator flashes quickly. When the white balance has been adjusted and stored in the memory, the indicator stops flashing. The setting will be maintained for about one hour after the battery is detached.



To return to automatic adjustments

Set AUTO LOCK selector to AUTO LOCK or press WHT BAL to turn off the white balance indicator.

Notes on the  indicator on the screen

- The state of the indicator shows as follows:
 - Slow flashing: white balance is not adjusted.
 - Fast flashing: white balance is being adjusted.
 - Lights up: white balance has been adjusted.
- When the  indicator remains flashing even if you press the control dial, shoot in automatic white balance mode.

Notes on white balance

- When you shoot with studio lighting or video lighting, use the  (indoor) mode.
- When you shoot with fluorescent lighting, use automatic white balance mode. If you use the  (indoor) mode, white balance may not be adjusted appropriately.

Shooting when lighting conditions change

- When lighting conditions have changed, readjust the white balance with the control dial while the camcorder is in Standby mode.
- When you adjust the exposure and shutter speed manually, and move from indoors to outdoors, or vice versa, adjust the white balance again.
- When you move from indoors to outdoors, or vice versa, or detach the battery for replacement while shooting in automatic white balance mode or set the POWER switch to CAMERA, point the camcorder at a white subject for about 10 seconds before you start recording.

Adjusting recording level

You can adjust the recording sound level. Use headphones to monitor the sound when you adjust.

- (1) Set the POWER switch to CAMERA.
- (2) Press MENU to display the menu.
- (3) Turn the control dial to select , then press the dial.
- (4) Turn the control dial to select MIC LEVEL, then press the dial.
- (5) Turn the control dial to select MANUAL, then press the dial.
- (6) Turn the control dial to select LEVEL SET, then press the dial.
- (7) Turn the control dial to adjust the microphone level, so that the peak indicator in the lower-right corner does not light up. It is recommended to use headphones (not supplied) to monitor the sound when making the adjustment.
- (8) Press MENU to erase the menu display.

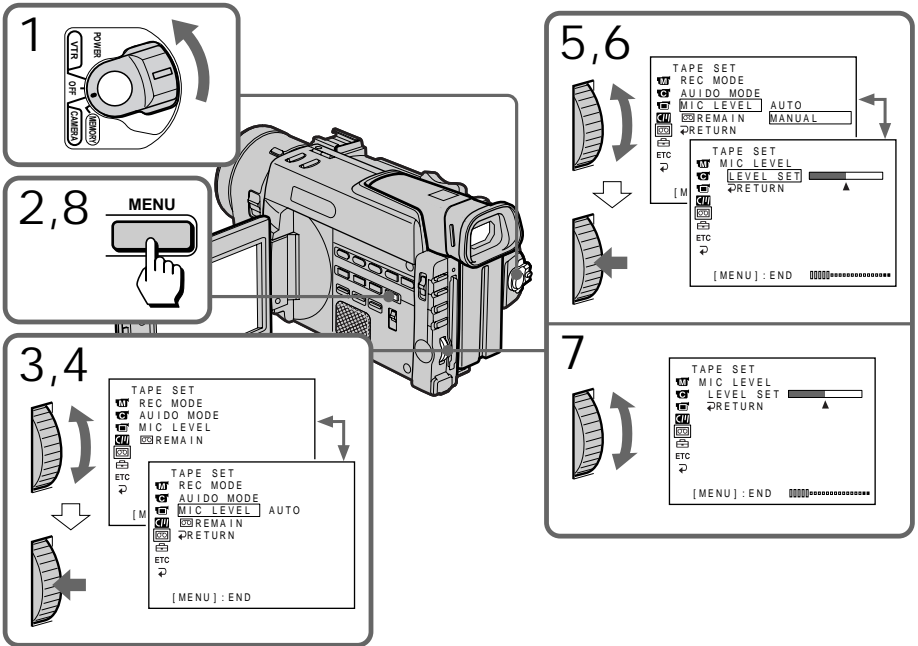

To adjust the microphone level automatically
Select AUTO in step 5, then press the control dial.

Notes on the adjustment

- The sound level setting is retained as long as the power is on and for about five minutes after removing the battery.
- Sound level indicator appears at the lower right on the LCD screen or in the viewfinder.

The sound input through the AUDIO/VIDEO jack
You cannot adjust the recording level of the sound.

Using the ND filter

Using the ND filter (corresponds to 16% of the quantity of light), you can record a picture clearly, preventing the picture from going out of focus under bright conditions.

When ND ON flashes on the LCD screen or in the viewfinder
The ND filter is necessary. Press ND FILTER so that the ND ON indicator appears.
The ND filter is now activated.

When ND OFF flashes on the LCD screen or in the viewfinder
The ND filter is not necessary. Press ND FILTER so that the ND OFF indicator stops flashing.
The ND filter is now deactivated.

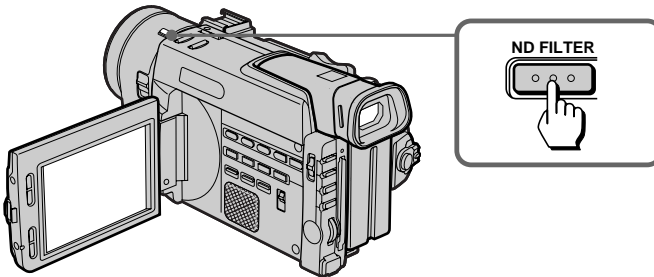

Shooting with the zebra pattern

You can set the camcorder to display a zebra pattern (diagonal stripes) in the portion of the picture on the LCD screen or in the viewfinder with a subject whose brightness exceeds a certain level. The portion of the picture where zebra pattern appears is an area of high brightness and overexposure. You can check the picture level of a subject by displaying the zebra pattern. Use the zebra pattern as a guide for adjusting the exposure and shutter speed so that you can get the desired picture.

- (1) Set the POWER switch to CAMERA.
- (2) Press MENU to display the menu.
- (3) Turn the control dial to select , then press the dial.
- (4) Turn the control dial to select ZEBRA, then press the dial.
- (5) Turn the control dial to select ON, then press the dial.
- (6) Press MENU to erase the menu display.

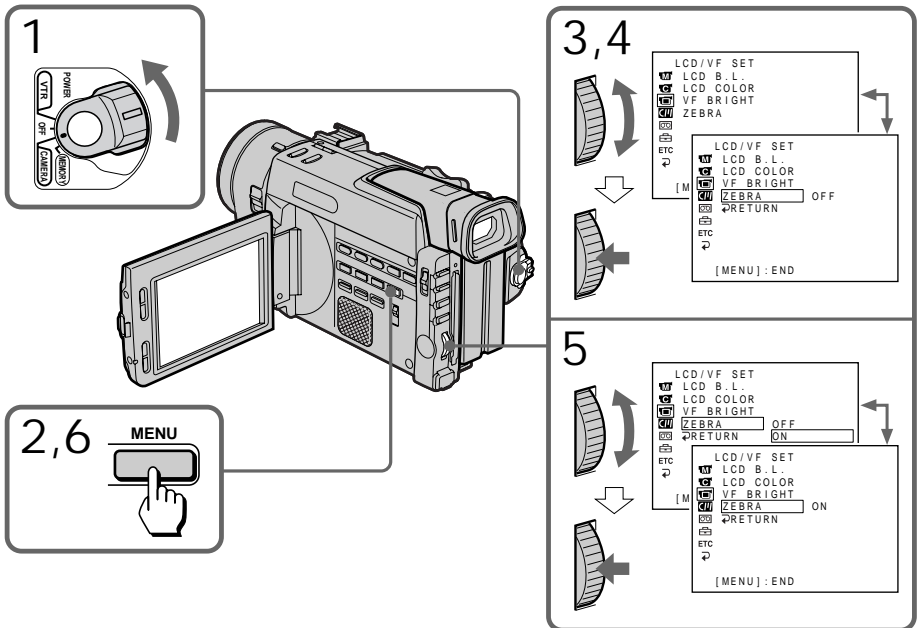

To erase the zebra pattern

Select OFF in step 5, then press the control dial.

Notes on shooting with the zebra pattern

- A zebra pattern appears at more than 100 IRE.
- Even though you see the zebra pattern on the LCD screen or in the viewfinder, the zebra pattern is not recorded.

Releasing the Steady Shot function

When the Steady Shot function is working, the camcorder compensates for camera-shake.

You can release the Steady Shot function when you do not need to use it. The  indicator appears on the LCD screen or in the viewfinder. Do not use the Steady Shot function when shooting a stationary object with a tripod.

- (1) Set the POWER switch to CAMERA.
- (2) Press MENU to display the menu.
- (3) Turn the control dial to select , then press the dial.
- (4) Turn the control dial to select STEADYSHOT, then press the dial.
- (5) Turn the control dial to select OFF, then press the dial.
- (6) Press MENU to erase the menu display.

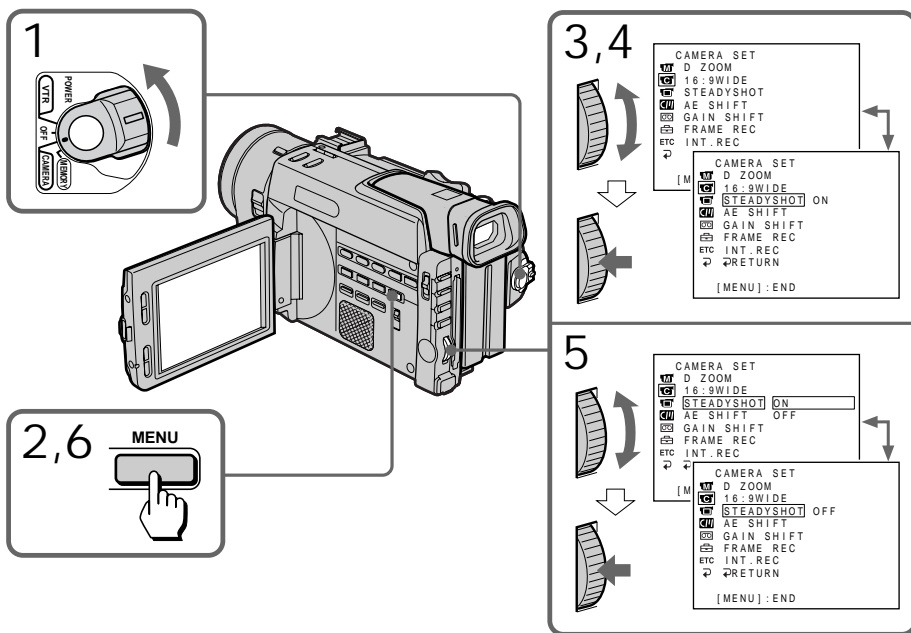

To activate the Steady Shot function again
Select ON in step 5, then press the control dial.

Notes on the Steady Shot function

- The Steady Shot function will not correct excessive camera-shake.
- If you use a tele conversion lens (not supplied) or a wide conversion lens (not supplied), the Steady Shot function may not work.

Adjusting AE shift

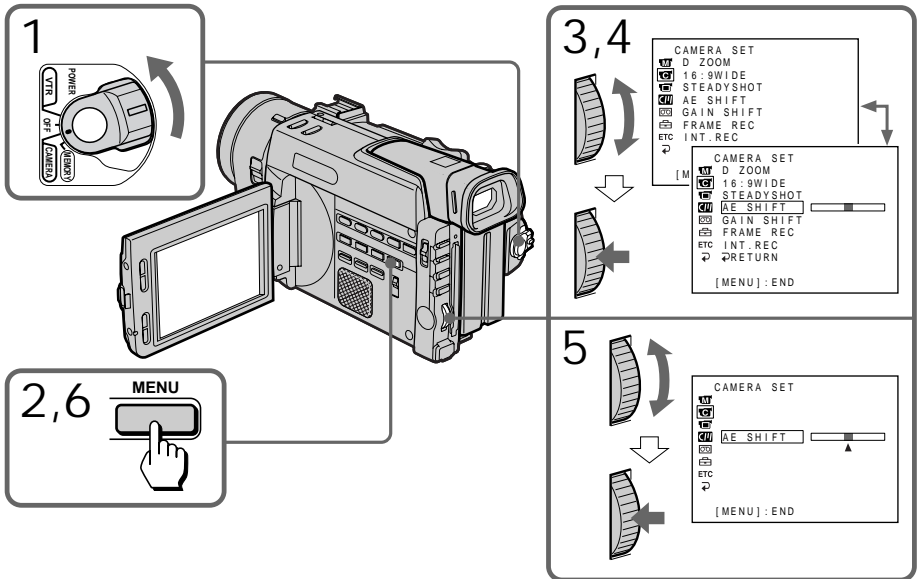

- (1) Set the POWER switch to CAMERA.
- (2) Press MENU to display the menu.
- (3) Turn the control dial to select , then press the dial.
- (4) Turn the control dial to select AE SHIFT, then press the dial.
- (5) Turn the control dial to adjust brightness, then press the dial.
Darker picture ↔ Brighter picture
- (6) Press MENU to erase the menu display.



To deactivate AE shift

Set the bar indicator at the center in step 5, then press the control dial.

When you adjust AE shift

The  -4 to  +4 indicator is displayed on the LCD screen or in the viewfinder. The number varies corresponding to the AE shift level.

Adjusting gain shift

- (1) Set the POWER switch to CAMERA.
- (2) Press MENU to display the menu.
- (3) Turn the control dial to select , then press the dial.
- (4) Turn the control dial to select GAIN SHIFT, then press the dial.
- (5) Turn the control dial to select -3dB, then press the dial.
- (6) Press MENU to erase the menu display.

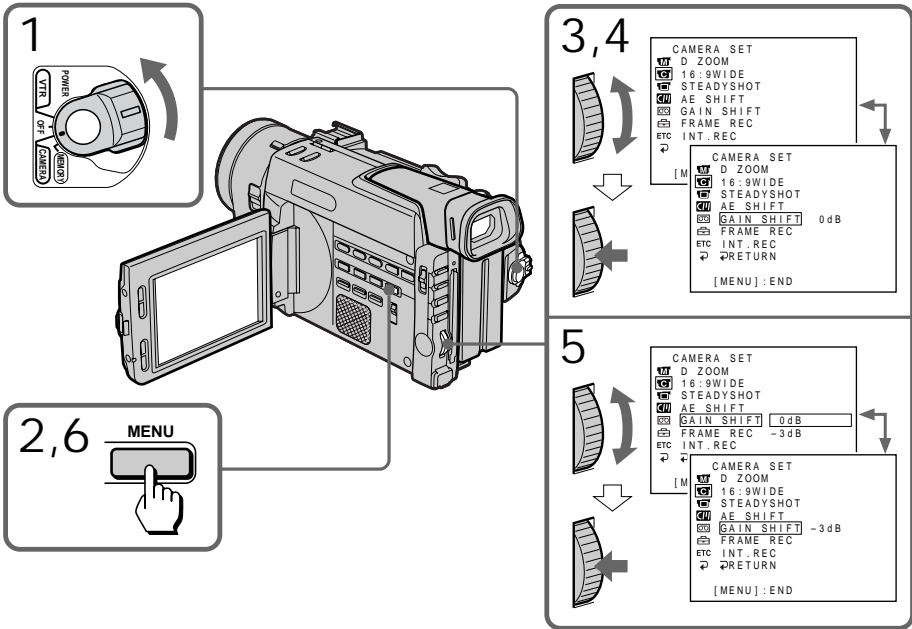

To deactivate gain shift
Select 0dB in step 5, then press the control dial.

What is gain shift

When shooting in bright conditions, the gain shift function automatically adjusts the automatic exposure control's gain value to -3dB as much as possible. This helps you shoot pictures with less noises in a bright condition. In dark conditions, the unit operates as usual.

When you adjust gain shift

The  indicator is displayed on the LCD screen or in the viewfinder.

Using the PROGRAM AE function

You can select from five PROGRAM AE (Auto Exposure) modes to suit your shooting situation, referring to the following.

Selecting the best mode

Select a proper PROGRAM AE mode referring to the following description.



AE A: Aperture priority mode

Selecting the aperture to determine the desired depth of field. Gain and the shutter speed are automatically set in combination with the aperture value to maintain appropriate exposure.

AE S: Shutter speed priority mode

Selecting the shutter speed manually. The exposure value changes in accordance with the selected shutter speed.

Sports lesson mode

Capturing high-speed action in sports such as golf or tennis

Sunset & Moon mode

Recording sunset, night views, fireworks or neon signs

Low lux mode

For recording a subject in insufficient light. Subject becomes bright.

Notes on focus setting

- In the Sports lesson mode, you cannot take close-ups because the camcorder is set to focus only on subjects in the middle to far distance.
- In the Sunset & Moon mode, the camcorder is set to focus only on distant subjects.

Using the PROGRAM AE function

- (1) Set AUTO LOCK selector to the center (auto lock release) position while the camcorder is in Standby or Recording mode.
- (2) Press PROGRAM AE.
- (3) Turn the control dial so that the symbol of the desired PROGRAM AE mode matches the indicator on the LCD screen or in the viewfinder.
When you select the aperture priority mode or the shutter speed priority mode, press the control dial.
- (4) In aperture priority mode (A/E A) or shutter speed priority mode (A/E S), turn the control dial to select the desired aperture value (F value) or shutter speed.
Aperture priority mode:
Turn the control dial to select the desired aperture value. As you turn the dial, the F value changes between F1.6 and F11.
For a smaller aperture, select a higher value. Gain and the shutter speed change in accordance with the selected aperture value.
Shutter speed priority mode:
Turn the control dial to select the desired shutter speed. As you turn the dial, shutter speed changes between 1/60 and 1/10000.
For a faster shutter speed, select a smaller value indicator on the LCD screen or in the viewfinder. The gain and aperture values change in accordance with the selected shutter speed.

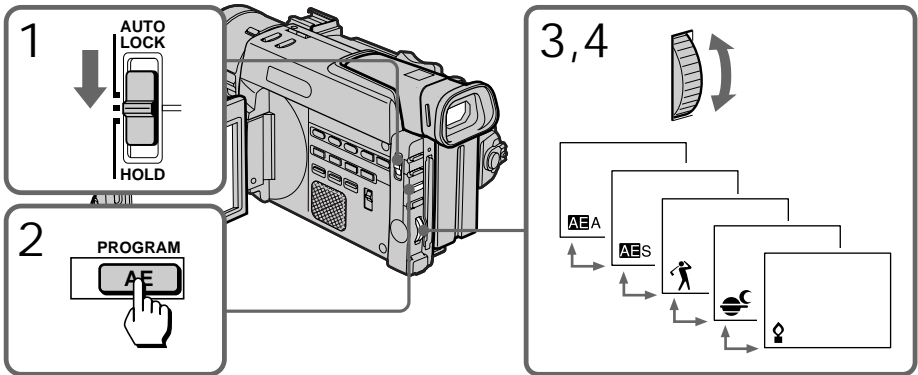

To return to automatic adjustment mode

Set AUTO LOCK selector to AUTO LOCK or press PROGRAM AE so that the indicator disappears.

When you focus in telephoto
You cannot choose F1.6, F2 and F2.4.

About the depth of field

The depth of field is the in-focus range, measured from the distance behind a subject to the distance in front. The depth of field can vary with the iris (F value) and the focal length. Lowering the F value (large iris) reduces the depth of field. Raising the F value (small iris) provides a larger depth of field. Zooming in telephoto position offers a smaller depth of field while the depth of field in wide-angle position is greater.

The depth of field	Shallow	Deep
Iris	Open (Low F value)	Close (High F value)
Zoom	Telephoto (T)	Wide (W)

Focusing manually

When to use manual focus

In the following cases you should obtain better results by adjusting the focus manually.

[a]



[b]

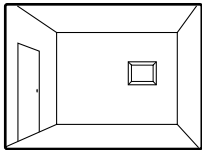

[c]



[d]

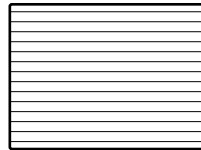

- Insufficient light [a]
- Subjects with little contrast — walls, sky, etc. [b]
- Too much brightness behind the subject [c]
- Horizontal stripes [d]
- Subjects through frosted glass
- Subjects beyond nets, etc.
- Bright subject or subject reflecting light
- Shooting a stationary subject when using a tripod

Adjusting focus manually

When focusing manually, first focus in telephoto before recording, and then reset the shot length.

- (1) Slide FOCUS down to MANUAL. The  indicator appears on the LCD screen or in the viewfinder.
- (2) Turn the focus ring to focus on the subject.

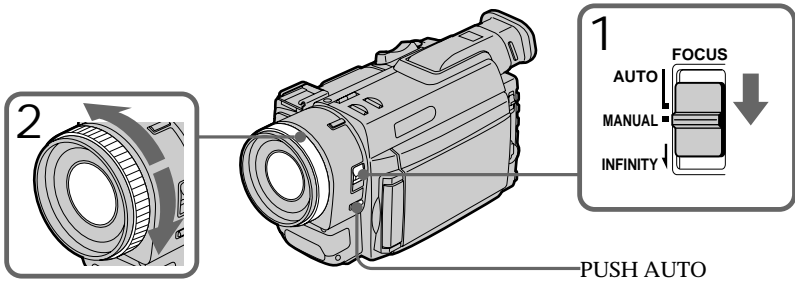

To focus in infinity

Slide FOCUS to INFINITY.  indicator appears on the LCD screen or in the viewfinder. This function is useful when the nearer subject is focused automatically, and you want to focus on a faraway subject.

To shoot with auto focusing momentarily



Press PUSH AUTO.

The auto focus functions while you are pressing PUSH AUTO.

Use this button to focus on one subject and then another with smooth focusing.

When you release PUSH AUTO, manual focusing resumes.

To return to the autofocus mode

Slide FOCUS up to AUTO to turn off  or  indicator.

To shoot in relatively dark places or to shoot the subject moving quickly outside



Shoot at wide-angle after focusing in the telephoto position.

If  lights up

Subject is too close.

Interval recording

You can make a time-lapse recording by setting the camcorder to automatically record and standby sequentially. You can achieve an excellent recording for flowering, emergence, etc., with this function.

- (1) Set the POWER switch to CAMERA.
- (2) Press MENU to display the menu.
- (3) Turn the control dial to select , then press the dial.
- (4) Turn the control dial to select INT.REC, then press the dial.
- (5) Turn the control dial to select SET, then press the dial.
- (6) Set INTERVAL and REC TIME.
 - ① Turn the control dial to select INTERVAL, then press the dial.
 - ② Turn the control dial to select the desired waiting time, then press the dial.
The time: 30SEC ↔ 1MIN ↔ 5MIN ↔ 10MIN.
 - ③ Turn the control dial to select REC TIME, then press the dial.
 - ④ Turn the control dial to select the desired recording time, then press the dial.
The time: 0.5SEC ↔ 1SEC ↔ 1.5SEC ↔ 2SEC.
 - ⑤ Turn the control dial to select , then press the dial.
- (7) Turn the control dial to select ON, then press the dial.
- (8) Press MENU to erase the menu display. The interval recording indicator flashes.
- (9) Press START/STOP to start interval recording. The interval recording indicator lights up.

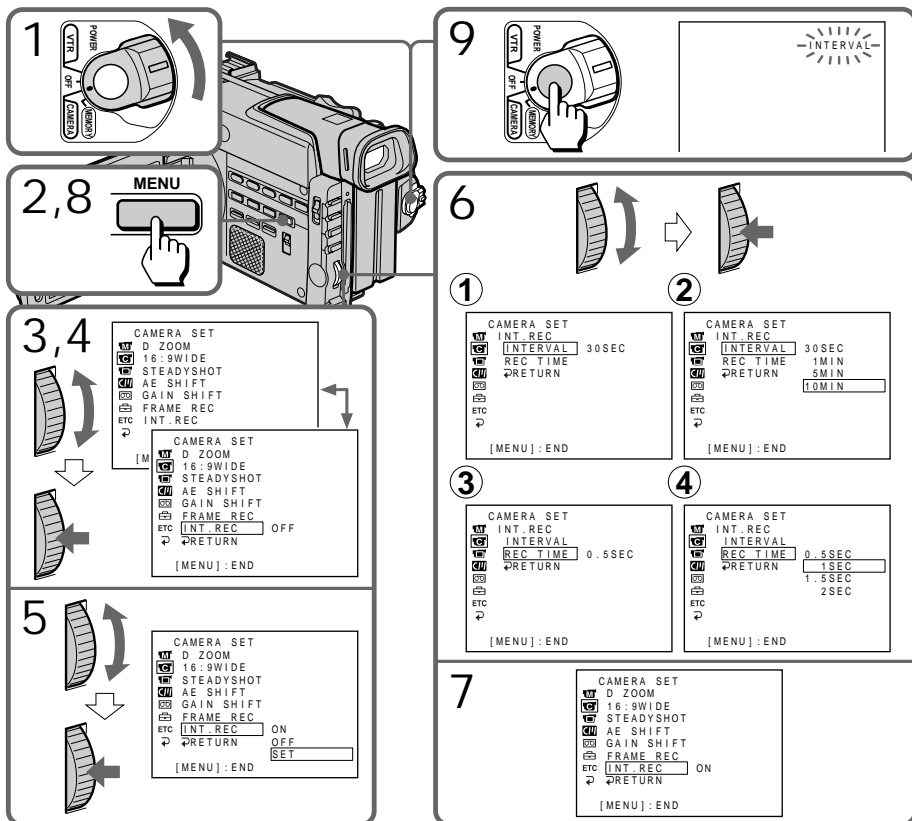

To cancel the interval recording

- Set INT.REC to OFF in the menu system.
- Set the POWER switch to OFF, VTR or MEMORY.

To stop the interval recording momentarily and perform normal recording

Press START/STOP. You can perform the normal recording only once. To cancel the normal recording, press START/STOP again.

During the interval recording mode

The INTERVAL indicator appears.

Notes on interval recording

- You cannot do interval recording with photo recording.
- You cannot perform interval recording in the MEMORY mode.
- There may be a discrepancy in recording time of up to +/- 6 frames from the selected time.

Cut recording

You can make a recording with a stop-motion animated effect using cut recording. To create this effect, alternately move the subject a little and make a cut recording. We recommend you to use a tripod, and to operate the camcorder using the Remote Commander in steps 7 and 8.

- (1) Set the POWER switch to CAMERA.
- (2) Press MENU to display the menu.
- (3) Turn the control dial to select , then press the dial.
- (4) Turn the control dial to select FRAME REC, then press the dial.
- (5) Turn the control dial to select ON, then press the dial.
- (6) Press MENU to erase the menu display.
- (7) Press START/STOP to start cut recording. The camcorder makes a recording for about six frames, and returns to recording standby.
- (8) Move the subject, and repeat step 7.

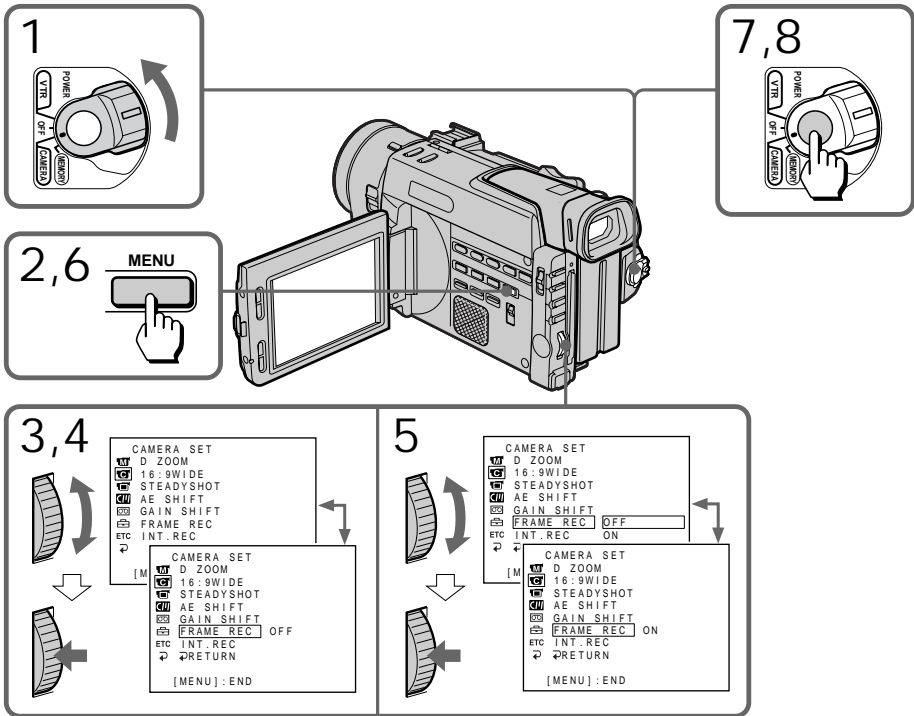

To cancel the cut recording

- Set FRAME REC to OFF in the menu system.
- Set the POWER switch to OFF, VTR, or MEMORY.

Notes on cut recording

- The last recorded cut is longer than other cuts.
- The proper remaining tape time is not indicated if you use this function continuously.

Superimposing a title

If you use a tape with cassette memory, you can superimpose the titles while recording or after recording. When you play back the tape, the title is displayed for five seconds from the point where you superimposed it.

You can select from eight preset titles and two original (CUSTOM TITLE) to superimpose over the picture.

Superimposing titles

- (1) Press TITLE to display the title menu.
- (2) Turn the control dial to select , then press the dial.
- (3) Turn the control dial to select the desired title, then press the dial. The titles are displayed.
- (4) Turn the control dial to select the color, size, or position, then press the dial.
- (5) Turn the control dial to select the desired item, then press the dial.
- (6) Repeat steps 4 and 5 until the title is arranged as desired.
- (7) Press the control dial again to complete the setting.
- (8) When you want to stop recording the title, press TITLE.

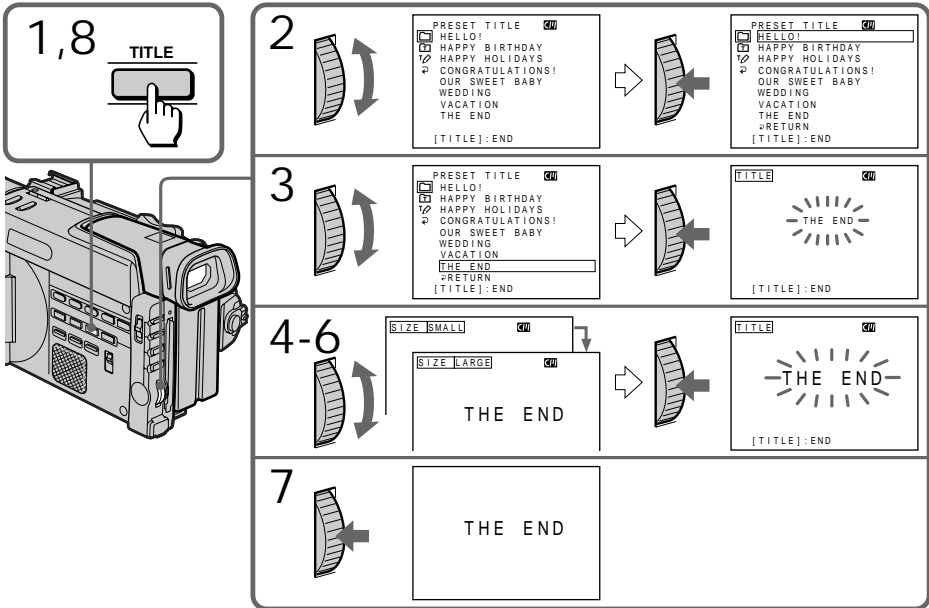

To superimpose the title from beginning
After step 7, press START/STOP to start recording.

To superimpose the title while you are recording
After pressing START/STOP to start recording, start from step 1. In this case, beep or melody is not heard.

To use the custom title
When you want to use the custom title, select  in step 2.

Notes on superimposing a title

- If you have not given any custom title, “- - - - ...” appears on the display.
- The FADER function works while the title is displayed, however, the title does not fade.
- If you display the menu or title menu while superimposing a title, the title is not recorded while the menu or title menu is being displayed.

Title color changes as follows:

WHITE ↔ YELLOW ↔ VIOLET ↔ RED ↔ CYAN ↔ GREEN ↔ BLUE

Title size changes as follows:

SMALL ↔ LARGE

Title position changes as follows:

When you select the title size “SMALL,” you can choose 9 positions. When you select the title size “LARGE” you can choose 8 positions.

Notes on the title

- Depending on size or position of the title, both of date and time or either of them is not displayed.
- If you input 13 characters or more for a LARGE title, the title is automatically reduced into a SMALL size after the position is set.
- When the title is displayed, LCD BRIGHT and microphone level indicators do not appear.

Erasing a title

- (1) Press MENU to display the menu.
- (2) Turn the control dial to select **CM**, then press the dial.
- (3) Turn the control dial to select TITLEERASE, then press the dial.
- (4) Turn the control dial to select the title you want to erase, then press the dial.
- (5) Make sure the title is the one you want to erase, then press the control dial again.
- (6) Press MENU to erase the menu display.

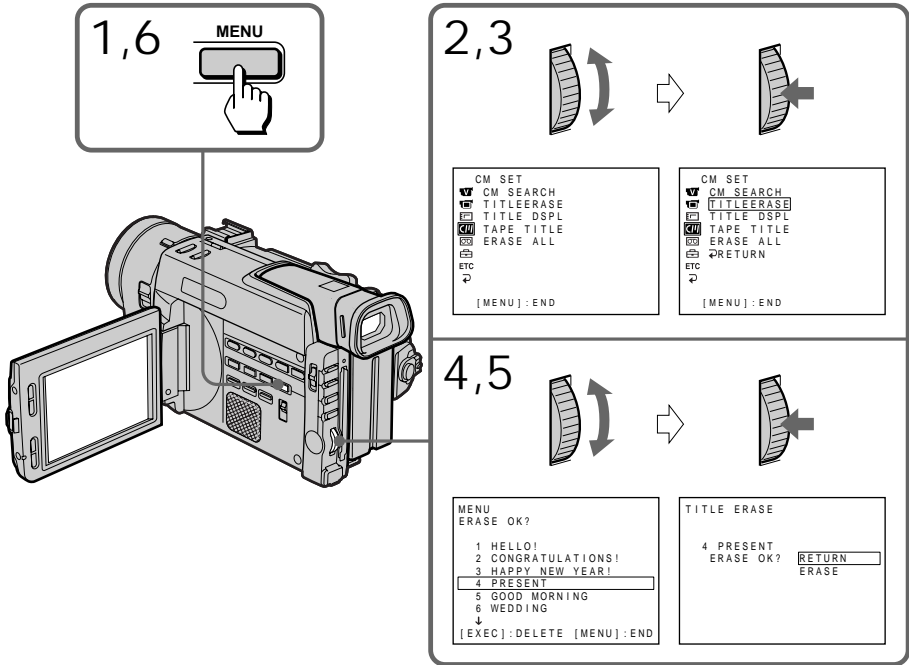

Note

If you use a cassette tape set to prevent accidental erasure, you cannot erase the title. Slide the protect tab so that the red portion is not visible.

Making a custom title

If you use a tape with cassette memory, you can make up to two titles and store them in the camcorder. We recommend you to set the POWER switch to VTR or eject the cassette before you begin.

Your title can have up to 20 characters.

- (1) Press TITLE to display the title menu.
- (2) Turn the control dial to select \varnothing , then press the dial.
- (3) Turn the control dial to select the first line (CUSTOM1) or second line (CUSTOM2), then press the dial.
- (4) Turn the control dial to select the column of the desired character, then press the dial.
- (5) Turn the control dial to select the desired character, then press the dial.
- (6) Repeat steps 4 and 5 until you finish the title.
- (7) To finish the titling work, turn the control dial to select [SET], then press the dial.

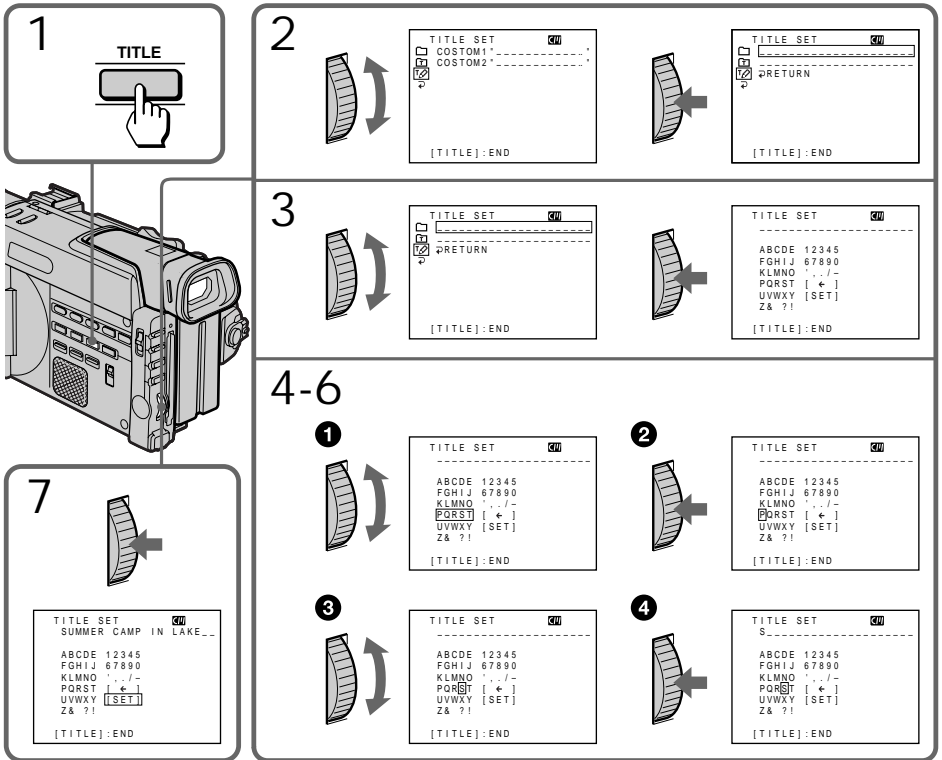

To edit a title you have stored

In step 3, select CUSTOM1 or CUSTOM2, depending on which title you want to edit, then change the title.

If you take 5 minutes or longer to enter characters while a cassette is in the camcorder the power goes off automatically. Characters you have entered remain. Set the POWER switch to OFF once, then to CAMERA, then proceed from step 1.

To erase a character

In step 4, turn the control dial to select [←] then press the dial. The last character is erased. Repeat this step until all characters are deleted.

Labeling a cassette

If you use a tape with cassette memory, you can label a cassette. The label can consist of up to 10 characters and is stored in cassette memory. When you insert the labeled cassette and turn the power on, the label is displayed on the LCD screen, in the viewfinder, or on the TV screen.

- (1) Insert the cassette you want to label.
- (2) Set the POWER switch to VTR.
- (3) Press MENU to display the menu.
- (4) Turn the control dial to select , then press the dial.
- (5) Turn the control dial to select TAPE TITLE, then press the dial.
- (6) Turn the control dial to select the column of the desired character, then press the dial.
- (7) Turn the control dial to select the desired character, then press the dial.
- (8) Repeat steps 6 and 7 until you finish the label.
- (9) Turn the control dial to select [SET], then press the dial.

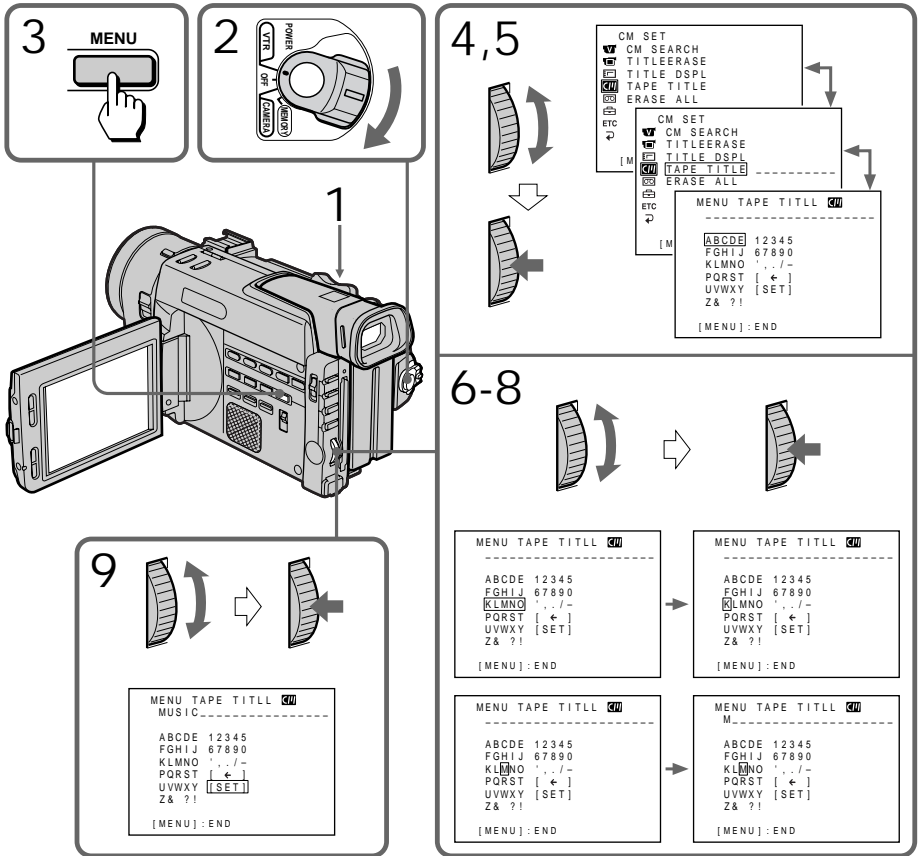

To erase a character

In step 6 turn the control dial to select [←], then press the dial. The last character is erased.

To change the label you have made

Insert the cassette to change the label, and operate in the same way to make a new label.

If the  mark appears in step 5

The cassette memory is full. If you erase the title in the cassette, you can label it.

If you have superimposed titles in the cassette

When the label is displayed, up to 4 titles also appear.

Note on “-----” indicator displayed on the LCD screen or in the viewfinder

The “-----” indicates the number of characters you can select for the label. When the “-----” indicator has fewer than 10 spaces, the cassette memory is full.

Note on the cassettes

If you use a cassette tape set to prevent accidental erasure, you cannot label it. Slide the protect tab so that the red portion is not visible.

Watching on a TV screen

Connect the camcorder to your TV or VCR to watch the playback picture on the TV screen. When monitoring the playback picture by connecting the camcorder to your TV, we recommend you to use house current for the power source.

Connecting directly to a TV or VCR with Audio/Video input jacks

Open the jack cover and connect the camcorder to the inputs on the TV by using the supplied A/V connecting cable. Set the TV/VCR selector on the TV to VCR.

Turn down the volume of the camcorder.

To get higher quality pictures in DV format, connect the camcorder to your TV using the S video connecting cable (not supplied).

If you are going to connect the camcorder using the S video connecting cable (not supplied) [a], you do not need to connect the yellow (video) plug of the A/V connecting cable [b].

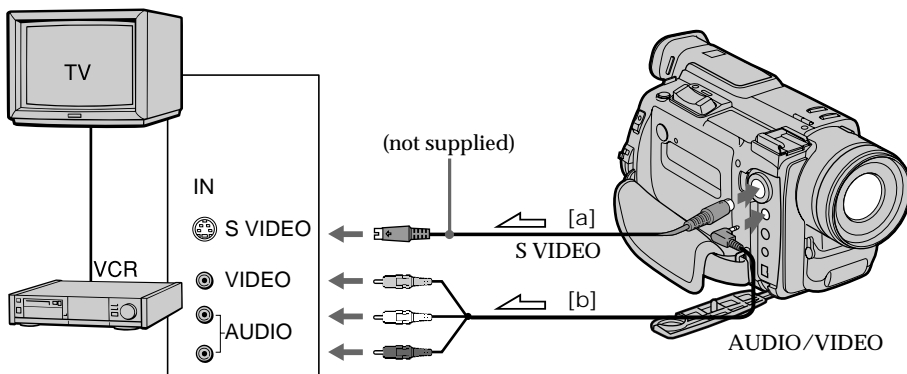

↔ : Signal flow

If your VCR or TV is a monaural type

Connect only the white plug for audio on both the camcorder and the VCR or the TV. If you connect the white plug, the sound is L (left) signal. If you connect the red plug, the sound is R (right) signal.

When you adjust the TV screen

Set COLOR BAR to ON in the menu system. The color bar is displayed on the TV screen.

Using the AV cordless IR receiver — LASER LINK

Once you connect the AV cordless IR receiver (not supplied) having the  LASER LINK mark to your TV or VCR, you can easily view the picture on your TV. For details, refer to the operating instruction of the AV cordless IR receiver.

LASER LINK is a system which transmits and receives a picture and sound between video equipment having the  mark by using infrared rays.



To play back on a TV

- (1) Set the POWER switch on the camcorder to VTR.
- (2) After connecting your TV and AV cordless IR receiver, set the POWER switch on the AV cordless IR receiver to ON.
- (3) Turn the TV on and set the TV/VCR selector on the TV to VCR.
- (4) Press LASER LINK. The lamp of the LASER LINK button lights up.
- (5) Press  on the camcorder to start playback.
- (6) Adjust the angle and direction of both the camcorder and AV cordless IR receiver.

To cancel the LASER LINK function

Press LASER LINK.

If you use a Sony TV

- You can turn on the TV automatically when you press LASER LINK or . To do so, set AUTO TV ON to ON in the menu system and turn the TV's main switch on, then do either of the following:
 - Point the LASER LINK emitter towards the TV's remote sensor and press LASER LINK.
 - Turn on the LASER LINK button and press .
- You can switch the video input of the TV automatically to the one which the AV cordless IR receiver is connected. To do so, set AUTO TV ON to ON and TV INPUT to the same video input (1, 2, 3) in the menu system. With some models, however, the picture and sound may be disconnected momentarily when the video input is switched.
- The above features may not work with some TV models.

Notes on LASER LINK

- When LASER LINK is activated (the LASER LINK button is lit), the camcorder consumes power. Press and turn off the LASER LINK button when it is not needed.
- When the conversion lens (not supplied) is installed, the transmission of infrared rays may be blocked.

You can use LASER LINK in the following situations:

- The POWER switch is set to VTR.
- The POWER switch is set to CAMERA without cassette inside (For demonstration at stores).

Viewing the picture with the picture effect

You can play back recorded images with the picture effect. The available picture effects are NEG. ART, SEPIA, B&W and SOLARIZE.

During playback, press PICTURE EFFECT.
See page 40 for details on the picture effect.

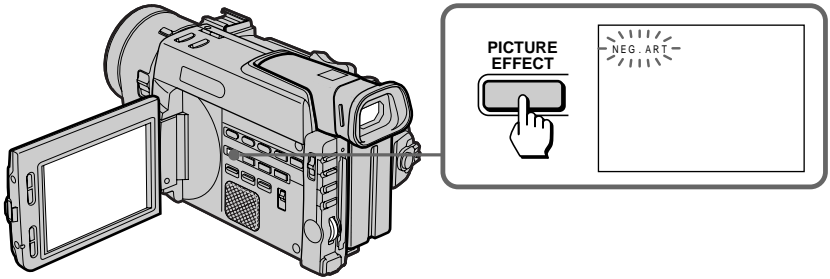

To return to normal mode

Press PICTURE EFFECT so that the indicator disappears.

If you turn the power off or stop playing back
The picture effect is automatically canceled.

The picture you apply picture effects to

The picture with the picture effect is not output through the  DV IN/OUT jack.

Viewing the picture with the digital effect

You can play back recorded images with the digital effect.

The available digital effects are STILL, FLASH, LUMI. and TRAIL.

- (1) During playback, press DIGITAL EFFECT.
- (2) Turn the control dial to select the desired digital effect mode.
- (3) Press the control dial. The digital effect indicator lights up and the bars appear. The still picture is stored in memory in the STILL or LUMI. mode.
- (4) Turn the control dial to adjust the effects.

See page 42 for details on the digital effect.

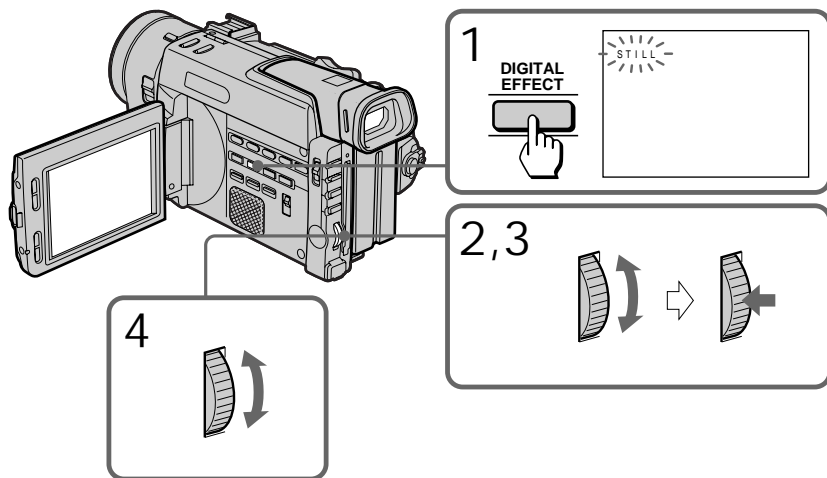

To return to normal mode

Press DIGITAL EFFECT so that the indicator disappears.

If you turn the power off or stop playing back

The digital effect is automatically canceled.

The picture you apply digital effects to

The picture with the digital effect is not output through the  DV IN/OUT jack.

Searching the boundaries of recorded tape with date – date search



You can search for the boundaries of recorded tape with date – Date Search function. To search the beginning of the specific date and play back from the point, there are two ways:

- Using cassette memory, you can select the date displayed on the LCD screen.
- Without using cassette memory.

You can only operate with the Remote Commander.

Searching for the date by using cassette memory

You can use this function only when playing back a tape with cassette memory (p. 116).

- (1) Set the POWER switch to VTR.
- (2) Press MENU to display the menu.
- (3) Turn the control dial to select CM SEARCH in , then press the dial.
- (4) Turn the control dial to select ON, then press the dial.
- (5) Press SEARCH MODE on the Remote Commander repeatedly, until the date search indicator appears.
- (6) Press  or  to select the date for playback. Playback starts from the beginning of the selected date automatically.

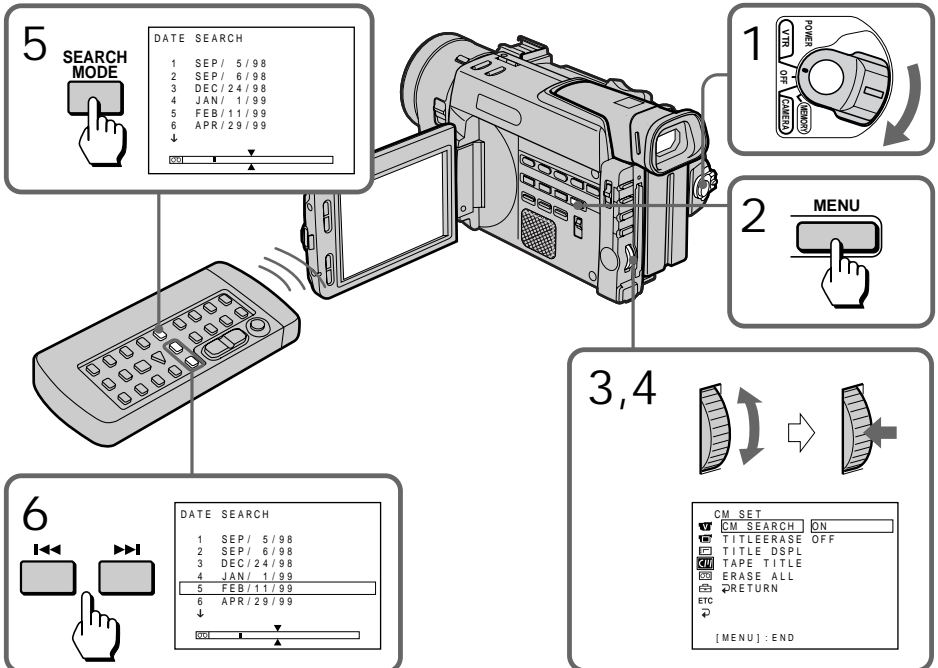





To stop searching
Press .

Notes

- The interval of the boundaries between the dates needs more than two minutes. The camcorder may not search if the beginning of the recorded date is too close to the next one.
- The black cursor on the screen indicates the date that was selected previously.
- If a tape has a blank portion in the beginning or between recorded portions, the date search function will not work correctly.
- Up to six date data can be stored in a cassette memory.

Searching for the date without using cassette memory

If you use the tape without cassette memory, skip steps 3 and 4.

- (1) Set the POWER switch to VTR.
 - (2) Press MENU to display the menu.
 - (3) Turn the control dial to select CM SEARCH in , then press the dial.
 - (4) Turn the control dial to select OFF, then press the dial.
 - (5) Press SEARCH MODE on the Remote Commander repeatedly, until the date search indicator appears.
 - (6) When the current position is [b], press  to search towards [a] or press  to search towards [c]. Each time you press  or , the camcorder searches for the previous or next date.
- Playback starts automatically when date changed.

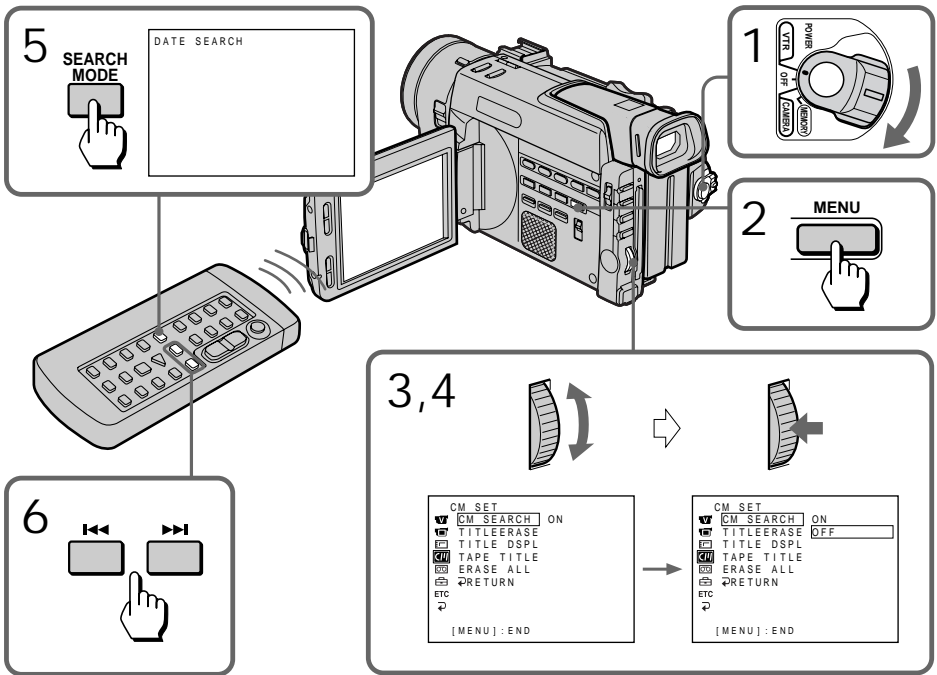
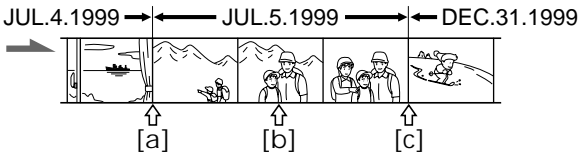

To stop searching
Press .



Searching the boundaries of recorded tape with title – title search

You can search for the boundaries of recorded tape with title – Title Search function. If you use a tape with cassette memory, you can select the title displayed on the LCD screen.

You can only operate with the Remote Commander.

Searching for the title by using cassette memory

You can use this function only when playing back a tape with cassette memory (p. 116).

- (1) Set the POWER switch to VTR.
 - (2) Press MENU to display the menu.
 - (3) Turn the control dial to select CM SEARCH in , then press the dial.
 - (4) Turn the control dial to select ON, then press the dial.
 - (5) Press SEARCH MODE on the Remote Commander repeatedly, until the title search indicator appears.
 - (6) Press  or  to select the title for playback.
- Playback starts from the scene of the selected title automatically.

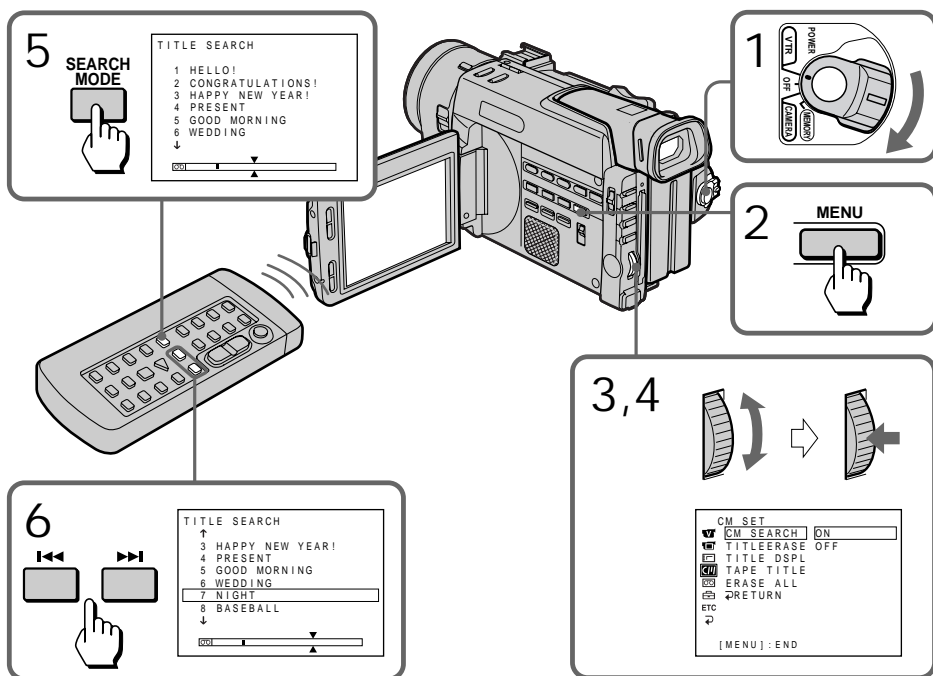

To stop searching
Press .

Notes

- You cannot superimpose or search a title, if you use a cassette tape without cassette memory.
- The camcorder may not search, if a tape has a blank portion in the between of the recorded portions.

Searching for a photo – photo search/photo scan

You can search for the recorded still picture – Photo Search function. There are two modes in Photo Search:



- Using cassette memory, you can select the recorded date which is displayed on the LCD screen.
- Without using cassette memory.

You can also search for still pictures one after another and display each picture for five seconds automatically – Photo Scan function. Even if your tape has no cassette memory, you can use the Photo Scan function.

You can only operate with the Remote Commander.

Searching for a photo by using cassette memory – photo search

You can use this function only when playing back a tape with cassette memory (p. 116).

- (1) Set the POWER switch to VTR.
 - (2) Press MENU to display the menu.
 - (3) Turn the control dial to select CM SEARCH in , then press the dial.
 - (4) Turn the control dial to select ON, then press the dial.
 - (5) Press SEARCH MODE on the Remote Commander repeatedly, until the photo search indicator appears.
 - (6) Press  or  to select the date for playback.
- Playback starts from the photo of the selected date automatically.

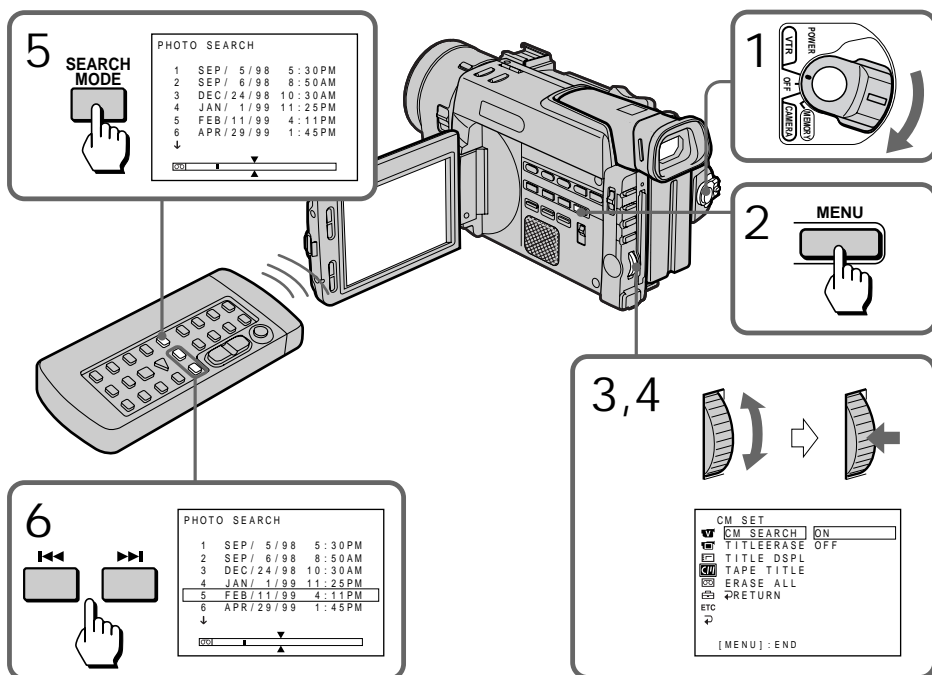

Searching for a photo – photo search/photo scan

To stop searching





Press ■.

Note

When you play back a tape which has a blank portion in the between of the recorded portions, the photo search function may not work correctly.

Searching for a photo without using cassette memory – photo search

If you use a tape without cassette memory, skip steps 3 and 4.

- (1) Set the POWER switch to VTR.
- (2) Press MENU to display the menu.
- (3) Turn the control dial to select CM SEARCH in , then press the dial.
- (4) Turn the control dial to select OFF, then press the dial.
- (5) Press SEARCH MODE on the Remote Commander repeatedly, until the photo search indicator appears.
- (6) Press  or  to select the photo for playback. Each time you press  or , the camcorder searches for the previous or next scene. Playback starts from the photo automatically.

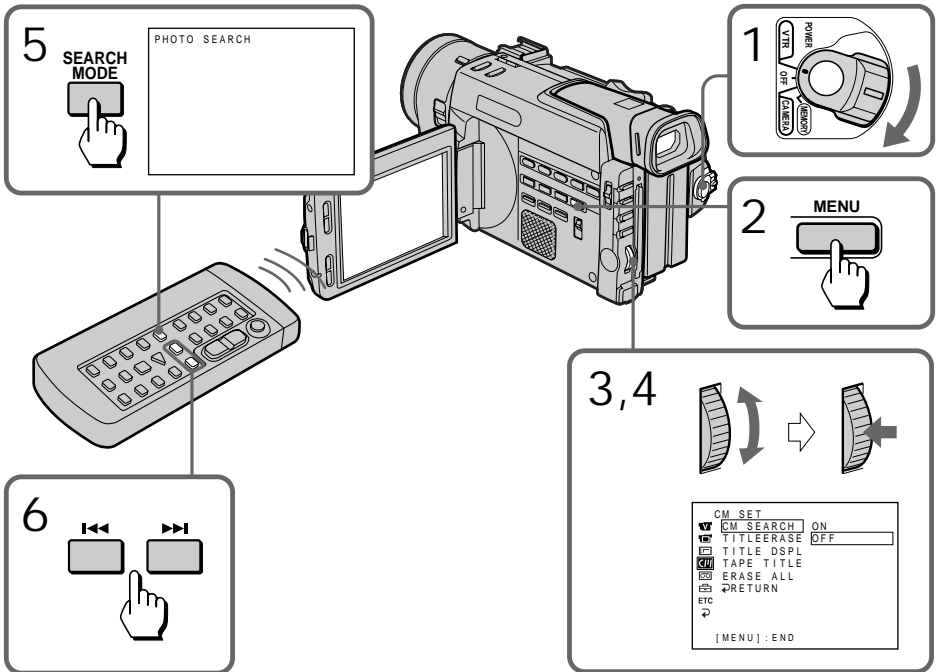

To stop searching

Press ■.

Scanning photo – photo scan

You can use this function whether the tape has cassette memory or not.

- (1) Set the POWER switch to VTR.
- (2) Press SEARCH MODE on the Remote Commander repeatedly until the photo scan indicator displayed on the LCD screen.
- (3) Press ◀◀ or ▶▶.

Each photo is displayed for about 5 seconds automatically.

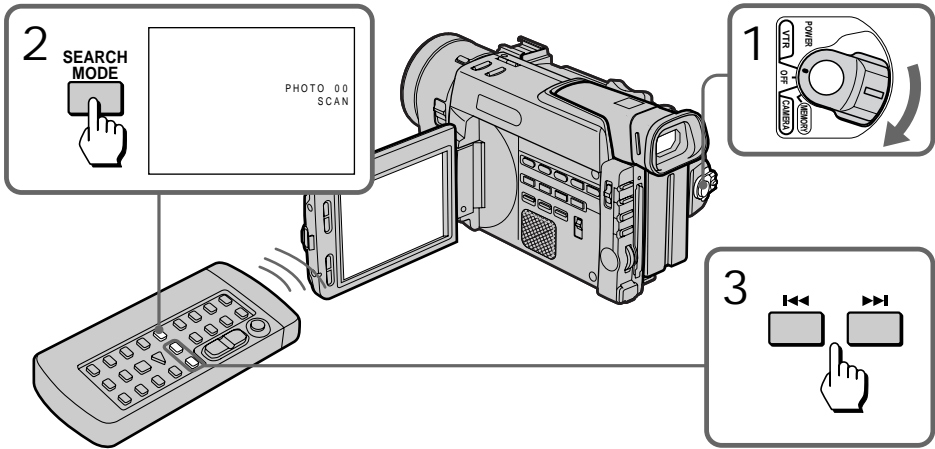

To stop scanning
Press ■.

Returning to a pre-registered position

Using the Remote Commander, you can easily go back to the desired point on a tape after playback.

- (1) During playback, press ZERO SET MEMORY at the point you later want to locate. The counter shows "0:00:00" and "ZERO SET MEMORY" appears on the LCD screen or in the viewfinder.
- (2) Press ■ when you want to stop playback.
- (3) Press ◀◀ to rewind or press ▶▶ to fast-forward the tape to the counter's zero point. The tape stops automatically when the counter reaches approximately zero. "ZERO SET MEMORY" disappears and the time code appears.
- (4) Press ▷.

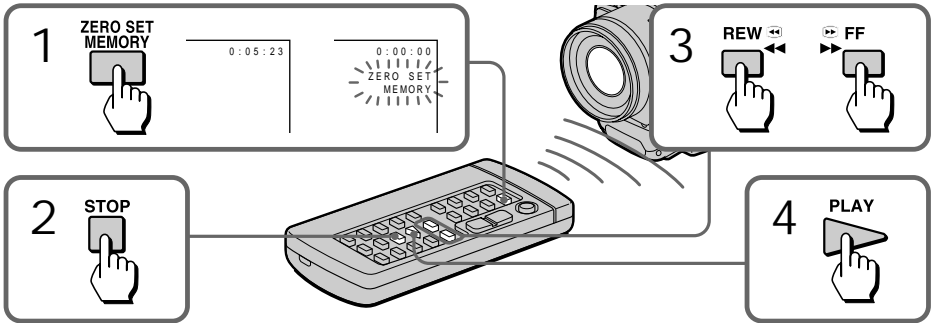

Note on the tape counter

There may be a discrepancy of several seconds from the time code.

Notes on ZERO SET MEMORY

- Press ZERO SET MEMORY again before step 3 to cancel the memory .
- ZERO SET MEMORY may not function when there is a blank portion between pictures on a tape.
- ZERO SET MEMORY functions in Standby mode.

Displaying recording data – data code function

You can display recording data (date/time or various settings when recorded) on the LCD screen or in the viewfinder during playback (Data Code). The Data Code is also displayed on the TV.

Press DATA CODE during playback.

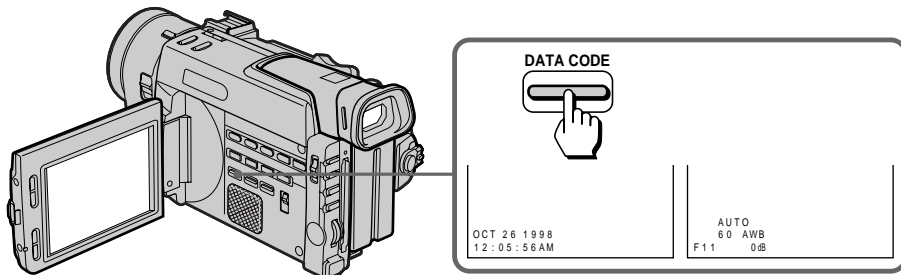

To select the items to be displayed

Set DATA CODE in the menu system, and select the following items:

When DATE/CAM is selected: date → various settings (SteadyShot, PROGRAM AE, shutter speed, white balance, aperture value, gain) → no indicator.

When DATE is selected: date → no indicator.

When you record a picture with adjusting the exposure to the darkest manually “CLOSE” appears at the position of the iris indicator on the LCD screen or in the viewfinder.

When bars (-- --) appear

- A blank portion of the tape is being played back.
- The tape was recorded by a camcorder without having date and time set.
- The tape is unreadable due to tape damage or noise.

Note

The pictures taken with the memory card slot is not recorded with the camera data.

Editing onto another tape

You can create your own video program by editing with any other **DV** DV, **Mini DV** mini DV, **8 mm**, **Hi8** Hi8, **VHS** VHS, **S-VHS** S-VHS, **VHS-C** VHS-C, **S-VHS-C** S-VHS-C, or **Betamax** VCR that has audio/video inputs. You can edit with little deterioration of picture and sound quality when using the i.LINK cable (DV connecting cable).

Before editing

Connect the camcorder to the VCR using the supplied A/V connecting cable or the VMC-IL4415/IL4435/2DV/4DV i.LINK cable (DV connecting cable) (not supplied).

Using the A/V connecting cable [a] or S video connecting cable (not supplied) [b]

Set the input selector on the VCR to LINE.

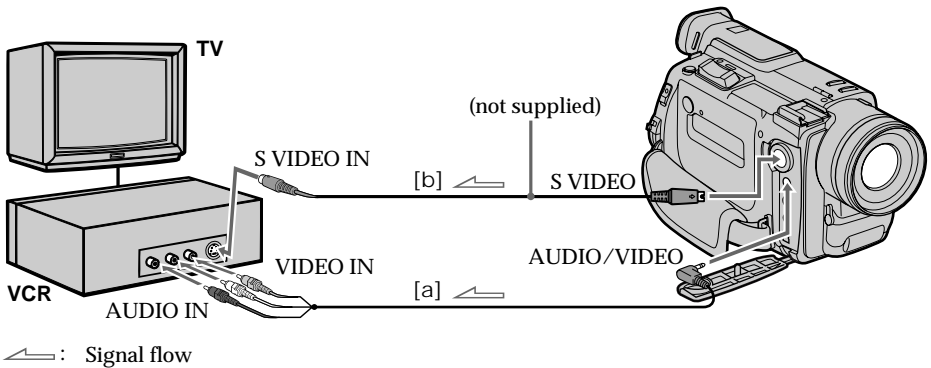

Notes on editing when using the A/V connecting cable

- Press DATA CODE, SEARCH MODE on the Remote Commander, or DISPLAY to turn off the display indicators. Otherwise, the indicators will be recorded on the tape.
- If your TV or VCR is a monaural type, connect the yellow plug of the A/V connecting cable for video to the TV or VCR. Connect only the white or red plug for audio to the TV or VCR. If you connect the white plug, the sound is L (left) signal. If you connect the red plug, the sound is R (right) signal.
- You can edit precisely by connecting a LANC cable to this camcorder and other video equipment having fine synchro-editing function, using this camcorder as a player.

Using the i.LINK cable (DV connecting cable)

Simply connect the VMC-IL4415/IL4435/2DV/4DV i.LINK cable (DV connecting cable) (not supplied) to DV IN/OUT and to DV IN/OUT of the DV products. With digital-to-digital connection, video and audio signals are transmitted in digital form for high-quality editing.

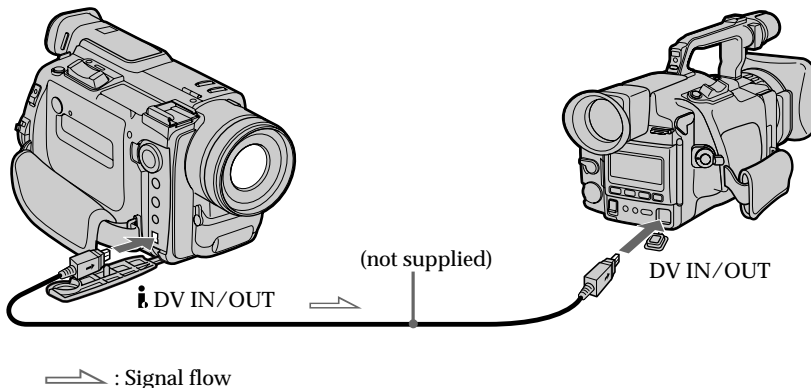

Notes on editing when using the i.LINK cable (DV connecting cable)

- You can connect one VCR only.
- You can record picture, sound and system data at the same time on the DV products by using the i.LINK cable (DV connecting cable) only.
- You cannot edit the titles, display indicator or the contents of cassette memory.
- If you record playback pause picture with the DV IN/OUT jack, the recorded picture becomes rough. And when you play back the picture using the other video equipment, the picture may jitter.
- You can also use the camcorder as a recorder with this connection. In this case "DV IN" indicator appears on the screen.
- When you use the camcorder as a recorder, the color balance may be incorrect on the monitor screen. But this is not recorded on the tape.

To perform a more precise editing
Use DV synchro-editing function. (see page 84)

Starting editing

- (1) Insert a blank tape (or a tape you want to record over) into the VCR, and insert your recorded tape into the camcorder.
- (2) Play back the recorded tape on the camcorder until you locate the point where you want to start editing, then press **II** to set the camcorder in playback pause mode.
- (3) On the VCR, locate the recording start point and set the VCR in recording pause mode.
- (4) Press **II** on the camcorder and VCR simultaneously to start editing.

To edit more scenes

Repeat steps 2 to 4.

To stop editing

Press **□** on both the camcorder and the VCR.

Editing partially on a mini DV tape – DV synchro-editing

By simply selecting the scenes to edit, you can duplicate the desired portion on a tape, using other equipment connected with an i.LINK cable (DV connecting cable). The scenes can be selected by frame. Since the camcorder exchanges digital signals, you can edit with little audio and video deterioration.

You cannot duplicate titles, display indicators or the contents of cassette memory. The connection is the same as on page 83.

- (1) Insert a recorded tape into the camcorder and insert a blank tape into the DV product.
- (2) Set the POWER switch of the camcorder to VTR.
- (3) Set the input selector to DV input on the DV product. If the DV product is another DV camcorder, set its POWER switch to VTR.
- (4) Press MENU to display the menu.
- (5) Turn the control dial to select ETC, then press the dial.
- (6) Turn the control dial to select DV EDITING, then press the dial.
- (7) Using the tape transport buttons, locate the point where you want to start editing, then press **II** to set the camcorder in playback pause mode.
- (8) Press the control dial or MARK on the Remote Commander to set DV EDITING IN.
- (9) Using the tape transport buttons, locate the point where you want to end editing, then press **II** to set the camcorder in playback pause mode.
- (10) Press the control dial or MARK on the Remote Commander to set DV EDITING OUT. The editing process starts. When the process ends, the camcorder and the DV product automatically set to pause mode.

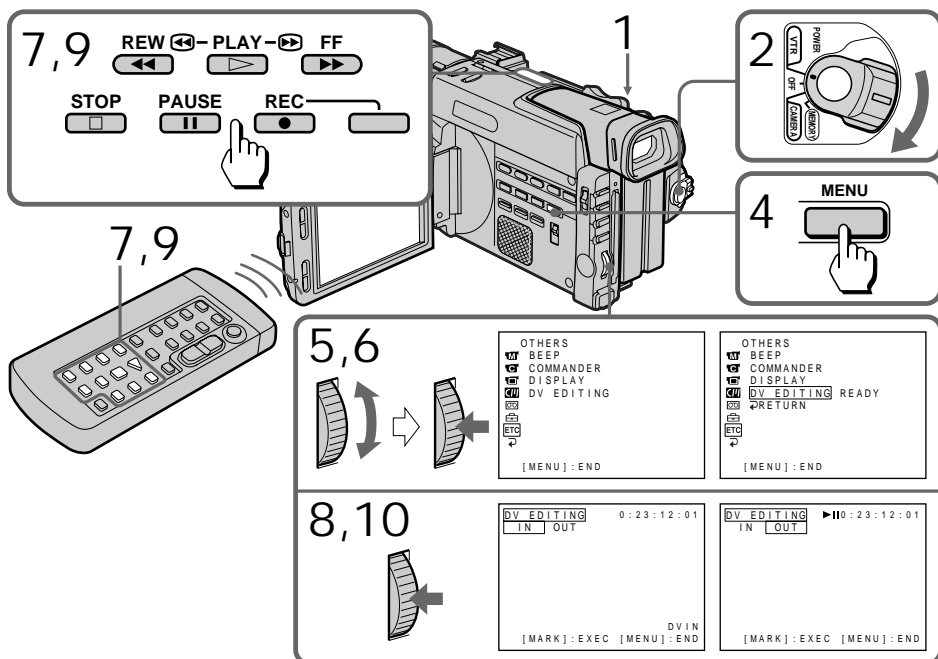

Notes

- If you use other than Sony DV equipment, you cannot perform DV synchro-editing.
- You cannot set DV EDITING IN or OUT on a blank portion of the tape.

Errors in duplicating

If you connect this camcorder to Sony equipment with DV jack, the range of errors is within ± 5 frames. The range may become wider in the following conditions.

- The interval between DV EDITING IN and OUT is less than five seconds.
- DV EDITING IN is set at the beginning of the tape.
- DV synchro-editing is performed repeatedly.

If you do not make connections with i.LINK cable (DV connecting cable)
The screen shows NOT READY, and you cannot select DV EDITING.

Recording from a VCR or TV

You can record a tape from another VCR or a TV program from a TV that has audio/video outputs. Connect the camcorder to the VCR or TV.

- (1) Set the POWER switch to VTR and set DISPLAY to LCD in the menu system.
- (2) Press ● REC and the button on the right together at the point where you want to start recording.

In recording and the recording pause mode, S VIDEO and AUDIO/VIDEO jacks automatically work as input jacks.

If your VCR or TV has an S video jack, connect using the S video cable (not supplied) [a] to obtain a high quality picture.

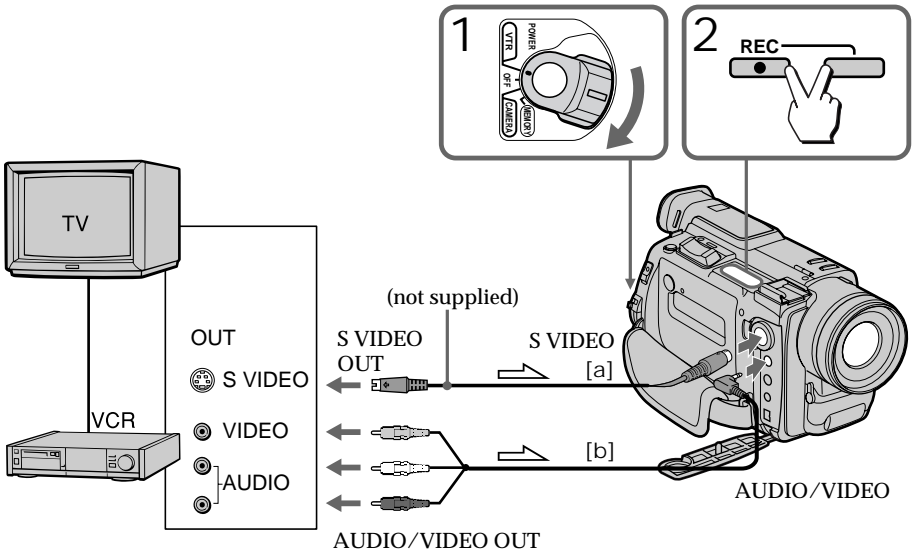

If your TV or VCR is a monaural type, connect the yellow plug of the A/V connecting cable for video to the TV or VCR. Connect only the white or red plug for audio to the TV or VCR. If you connect the white plug, the sound is L (left) signal. If you connect the red plug, the sound is R (right) signal.

If you are going to connect the camcorder using the S video cable (not supplied) [a], you do not need to connect the yellow (video) plug of the A/V connecting cable [b].

Notes

- If the S video plug is not provided on your TV or VCR, do not connect the S video cable (not supplied) to the camcorder. Pictures will not appear.
- The dual sound cannot be recorded in this camcorder.
- If you fast-forward or slow-playback on the other equipment, the image being recorded may turn black and white. When recording from other equipment, be sure to play back the original tape at normal speed.

To stop recording

Press □.

Replacing recording on a tape – insert editing

You can insert a new scene from a VCR onto your originally recorded tape by specifying starting and ending points. After inserting, the previous picture and sound will be erased. Connection is the same as on page 82 or 83. In recording and recording pause mode, i DV IN/OUT jack automatically works as an input jack.

You can only operate with the Remote Commander.

- (1) Set the POWER switch to VTR.
- (2) On the VCR, locate the start point to be inserted and set it to playback pause mode.
- (3) On the camcorder, press \triangleright to set it to playback mode, and then locate the point where the insert should end by pressing \lll or \ggg . Then press \parallel to set it to playback pause mode.
- (4) Press ZERO SET MEMORY on the Remote Commander. The ZERO SET MEMORY indicator flashes and the end point of the insert is stored in memory.
- (5) On the camcorder, locate the point where the insert should begin by pressing \lll , then press \bullet REC to set it to recording pause mode.
- (6) Press \parallel on the camcorder and the VCR simultaneously to start insert editing. The insert editing stops automatically near the counter's zero point. Press \square to set the camcorder to stop mode.

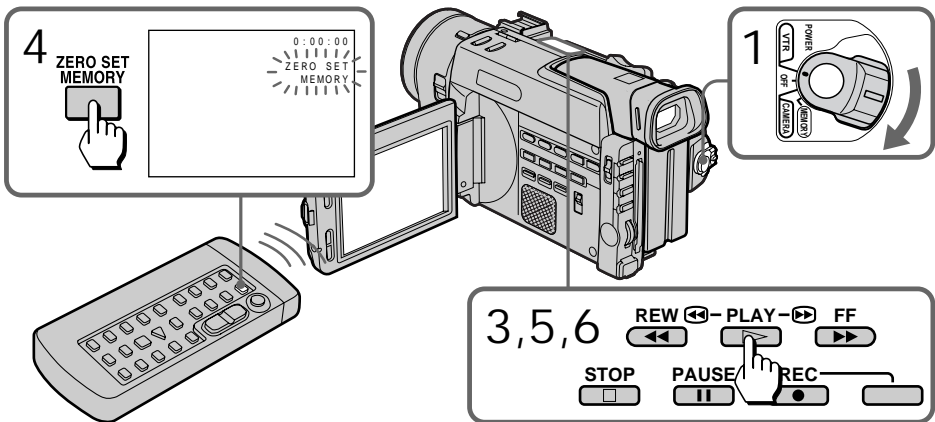

To change the end point

Press ZERO SET MEMORY on the Remote Commander so that the ZERO SET MEMORY indicator disappears and begin from step 3.

Note on the inserted picture

The picture may be distorted at the end of the inserted portion when it is played back.

Audio dubbing

You can record an audio sound to add to the original sound on a tape by connecting audio equipment or a microphone. If you connect the audio equipment, you can add sound to your recorded tape by specifying the starting and ending points. The original sound will not be erased.

You can only operate with the Remote Commander.

Connecting the microphone with the MIC jack

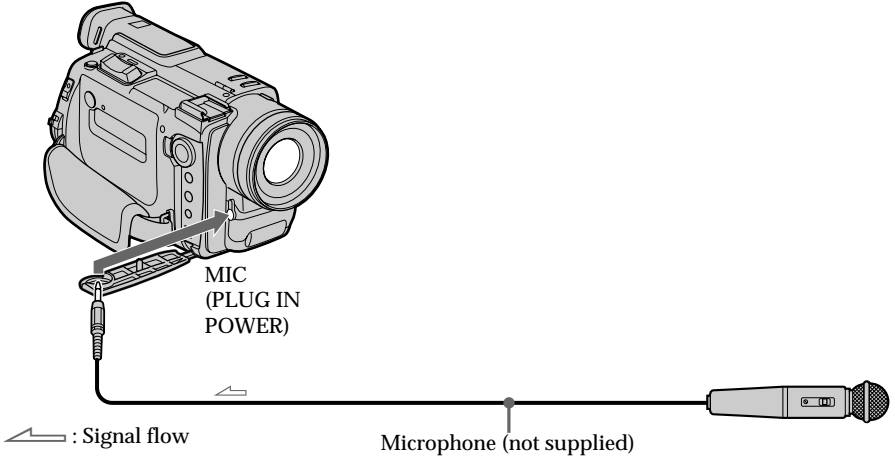

Note

You can check the recorded picture and sound by connecting the AUDIO/VIDEO jack to a TV.

The recorded sound is not output from a speaker. Check the sound by using the TV or headphones.

Connecting the microphone with the intelligent accessory shoe

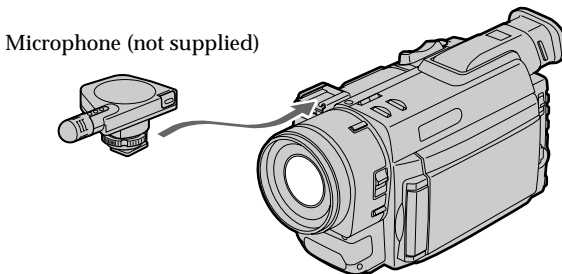

Dubbing with the AUDIO/VIDEO jack

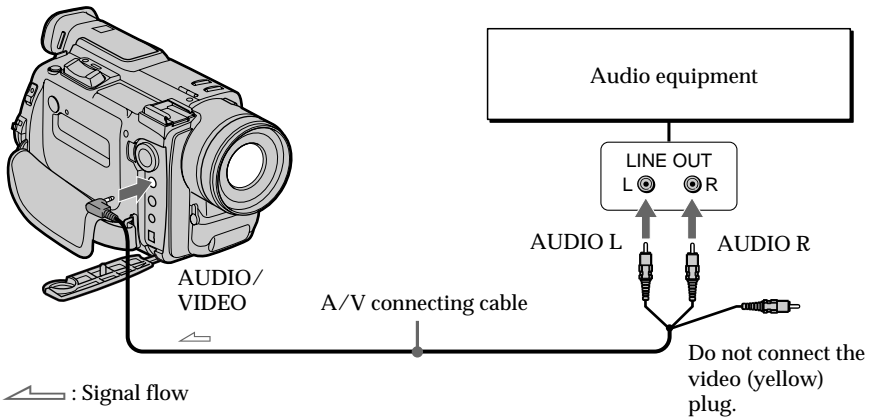

Note

The picture is not output from the AUDIO/VIDEO jack. Check the recorded picture on the LCD screen or in the viewfinder, as well as check the recorded sound by using a speaker or headphones.

Dubbing with the built-in microphones

No connection is necessary.

Adding an audio sound on a recorded tape

- (1) Insert your recorded tape into the camcorder.
- (2) Set the POWER switch to VTR.
- (3) On the camcorder, locate the point where the recording should begin by pressing ◀▶. Then press || to set it to playback pause mode.
- (4) Press AUDIO DUB on the Remote Commander .
- (5) Press || on the Remote Commander and at the same time start playing back the audio you want to record.
- (6) Press ■ on the Remote Commander at the point where you want to stop recording.

To play back the new recorded sound

Adjust the balance between the original sound (ST1) and the new sound (ST2) by selecting AUDIO MIX in the menu system.

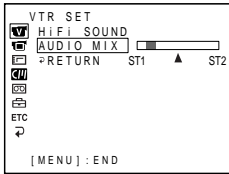

Five minutes after when you disconnect the power source or remove the battery pack, the setting of AUDIO MIX returns to the original sound (ST1) only. The factory setting is original sound only.

To end audio more precisely

First, press ZERO SET MEMORY on the Remote Commander at the point where you want to stop recording. Then start recording from step 3, and the recording stops automatically near the counter's zero point.

If you make all the connections

The audio input to be recorded will take precedence over others in the following order.

- MIC (PLUG IN POWER) jack
- Intelligent accessory shoe
- AUDIO/VIDEO jack
- Built-in microphone

If an i.LINK cable (DV connecting cable) is connected to this unit

You cannot add a sound to a recorded tape.

If you disconnect or connect a cable to the camcorder during recording

The recording may stop.

Notes on audio dubbing

- A new sound cannot be recorded on a tape already recorded in the 16-bit mode (32 kHz, 44.1 kHz or 48 kHz).
- When an external microphone is not connected, the recording will be made through the built-in microphone of the camcorder.
- A new sound cannot be recorded on a tape already recorded in the LP mode.
- If you add a new sound on a tape recorded with another camcorder (including DCR-TRV900), the sound quality may become worse.
- You cannot add audio with the  DV IN/OUT jack.

Using the memory card slot – introduction

This camcorder is equipped with a memory card slot that conforms to ATA specification of PC Card standard.

You can record still images to floppy disks using the supplied floppy disk adapter, Memory Sticks (not supplied) or PC cards (not supplied). You can exchange image data with other equipment such as personal computers etc., using floppy disks, Memory Sticks or PC cards.

CAUTION!

Do not carry around this camcorder with the floppy disk adapter connected.

Image

Record the still image on floppy disk with the floppy disk adapter. Play back the picture with your PC.

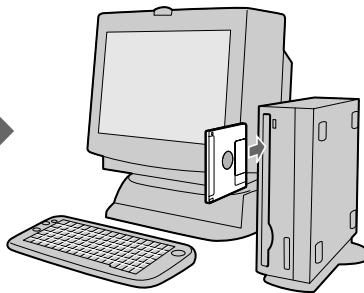
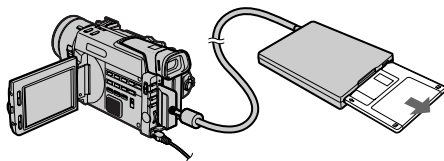

Instruction of functions

The illustrations used in this chapter for the instruction are that of the floppy disk adapter unless specified otherwise.

Sony recommends Memory Sticks

Sony recommends using the MSAKIT-PC4A Memory Stick/PC card kit (not supplied). The Memory Stick is a brand new type of recording medium that records images and sounds as digital data and operates just like a PC card. For detailed instructions, refer to the operating instruction supplied with Memory Stick/PC card kit.

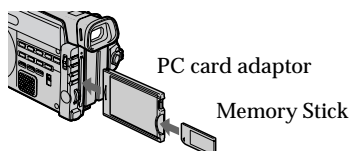

The types of PC cards you can use

Use TYPE II PC cards that conform to ATA specification of PC card standard. Format the PC card with this camcorder before use. Once you format the PC card, you can store data of up to 64 MB in it.

Compatible PC cards

HITACHI

HB286008A3, HB286015A3, HB286030A3, HB286045A3, HB286060A3

Be sure to refer to the instruction manual supplied with the PC card.

Notes on the supplied floppy disk adapter

The floppy disk adapter is designed for use only with this camcorder. The adapter is not warranted to function properly if used with other equipment.

Floppy disks you can use with this unit

- Size : 3.5 inch
- Type : 2HD
- Capacity : 1.44 MB
- Format : MS-DOS format (512 bytes x 18 sector)

When using a 3.5 inch, 2HD floppy disk other than that described above, format it using the camcorder.

On file format (JPEG)

This unit compresses image data in JPEG format (extension .jpg) and simultaneously records thumbnail data (extension .411) for the index screen. The index screen data is varies only on this unit.

Data file names of image

MVC00001.jpg: if saved on a PC card

MVC-0001.jpg: if saved on a floppy disk

Be sure to place the adapter on a stable surface

Placing the floppy disk adapter on an unstable or slanting surface or holding the adapter by hand during operation may result not only in malfunction of the unit but also in injury.

Do not shake or jar the adapter

Malfunctions, inability to record images or inability to use floppy disks may occur. There may be also image and memory data breakdown, damage or loss.

Do not get the adapter wet

The floppy disk adapter does not function when it is wet. Be careful not to get the adapter wet. When moving the adapter from one atmospheric condition to another, moisture condensation may occur inside or outside the unit. If this occurs, follow the instructions on page 121 and remove any condensation before use.

Notes on the floppy disk

To protect data recorded on the floppy disks, note the following:

- Avoid storing floppy disks near magnets or magnetic fields such as those of speakers and televisions, permanent erasure of disk data may result.
- Avoid storing floppy disks in areas subject to direct sunlight or sources of high temperature, such as heating devices. Floppy disk warping or damage may result, making the disk useless.
- Avoid contact with the disk surface by opening the disk shutter plate. If the disk surface becomes blemished, data may be unreadable.
- Keep liquids away from the floppy disk.
- Be sure to use a floppy disk case to protect important data.
- Use only a 2HD type disk head cleaner when cleaning the disk drive.
- Even when you use a 3.5 inch 2HD floppy disk, image data may not be recorded and/or displayed depending on the using environment. In this case, use another brand of disk.

About the power source

When you use the memory card slot, getting the power from a wall outlet is recommended, using the AC power adaptor.

Using the memory card slot – introduction

About the remaining battery indicator

This camcorder displays remaining recording/playback time on the LCD screen or in the viewfinder. This function may not work properly in certain operating conditions. Especially when using the memory card slot, the correct remaining time may not be indicated due to increased power consumption. This is not a malfunction.

Power supply

When using a video light (not supplied) or similar equipment connected to the intelligent accessory shoe of the camcorder, recording an image to a floppy disk or PC card may result in a temporary power shortage in the accessory shoe, causing the video light to go out. This does not affect other functions.

When using a battery case

When using a battery case (not supplied) such as the EBP-L7, you cannot perform operations that require the floppy disk adapter. The screen displays “FOR “InfoLITHIUM” BATTERY ONLY.”

Note on playback compatibility

This camcorder is not guaranteed to properly play back images shot with other equipment. The images shot with this camcorder are not guaranteed to be played back properly with other equipment.

CAUTION

Do not insert your finger or an object into the memory card slot.

Connecting the floppy disk adapter or PC card

With the upper side of the connector facing the LCD panel, insert the connector until it clicks.

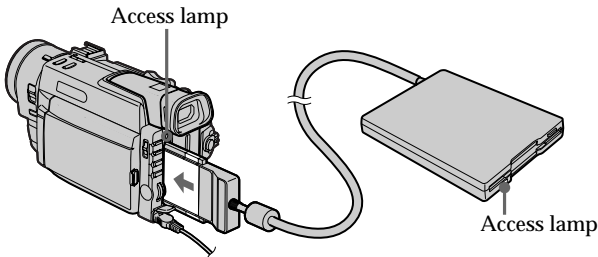

To eject the floppy disk adapter or PC card

Slide the MEMORY RELEASE lever in the direction of the arrow as illustrated below.

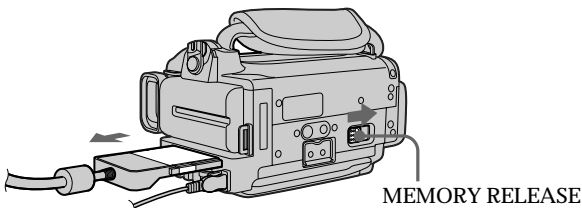

When the access lamp is flashing

Never shake or strike the unit. Do not turn the power off, eject a PC card/floppy disk adapter or remove the battery pack. Otherwise, the image data breakdown may occur.

Inserting a floppy disk

Insert a floppy disk until it clicks.

Before inserting, check that the write protect tab is set to the recordable position for recording a still picture.

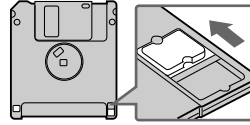
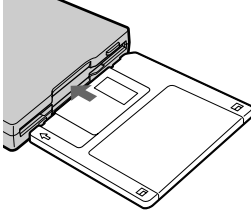

To eject the floppy disk

Press the floppy disk eject button.

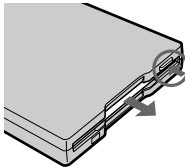

Floppy disk eject button

About the PC card and memory slot connector of the floppy disk adapter

To protect the recorded data, follow the instructions below.

- Do not repair, make alterations, or dismantle the them.
- Avoid using the card in direct sunlight, in extreme heat or cold, in damp or dusty locations.
- Do not spill liquid on the them.
- Do not fold or strike the them.

When the PC card does not come out

Remove the battery before ejecting the PC card.

The front edge of the memory slot connector

Do not touch the front edge of the memory slot connector with your hand.



Front edge of the memory slot connector

Note

Unless you press any memory operating buttons after inserting another floppy disk, the  indicator may not disappear from the screen.

Selecting the image quality mode

You can select one of three image quality modes in still picture recording. If you do not make any selection, the unit automatically records in SUPER FINE mode.

- (1) Set the POWER switch to MEMORY. Make sure that the lock knob is set to the right (unlock) position.
- (2) Press MENU to display the menu.
- (3) Turn the control dial to select , then press the dial.
- (4) Turn the control dial to select QUALITY, then press the dial.
- (5) Turn the control dial to select desired image quality, then press the dial.
- (6) Press MENU to erase the menu display.

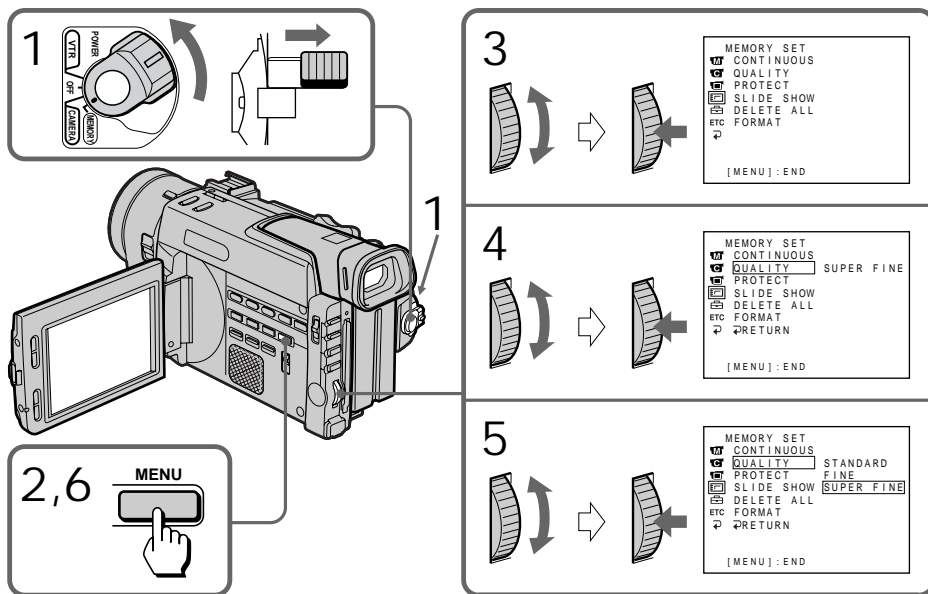

Setting image quality

Setting	Meaning
SUPER FINE (SFN)	This is the highest image quality in this camcorder. The number of still images you can record is less than FINE. The image is compressed to about 1/4.
FINE (FIN)	Use this mode when you want to record high quality images. The image is compressed to about 1/6.
STANDARD (STD)	This is the standard image quality. The image is compressed to about 1/10.

The difference in image quality mode

A recorded image is compressed in JPEG format before stored into memory. The memory capacity allotted to each image varies depending on the selected quality mode. Details are shown in the table below. (The number of pixel is 640 x 480, regardless of image quality mode. Data volume before compression is about 600 KB.)

Image quality mode	Memory capacity
SUPER FINE	About 150 KB
FINE	About 100 KB
STANDARD	About 60 KB

Approximate numbers of images you can record on a floppy disk

The number of images you can record is different depending on which image quality mode you select and the complexity of the subject.

SUPER FINE (SFN) about 7 to 8 images
FINE (FIN) about 14 to 16 images
STANDARD (STD) about 23 to 27 images

Note

In some cases, changing image quality mode may not affect the image quality, depending on the types of images you are shooting.

Formatting (initializing) a PC card or a floppy disk

- (1) When you format a floppy disk, insert a disk into the floppy disk adapter. When you format a PC card, insert the card into the memory card slot.
- (2) Set the POWER switch to MEMORY. Make sure that the lock knob is set to the right (unlock) position.
- (3) Press MENU to display the menu.
- (4) Turn the control dial to select , then press the dial.
- (5) Turn the control dial to select FORMAT, then press the dial.
- (6) Turn the control dial again to select OK, then press the dial. The display shows "EXECUTE."
- (7) Press the control dial. The display shows "FORMATTING," and formatting procedure begins. When formatting is finished, the display shows "COMPLETE."

Using the memory card slot – introduction

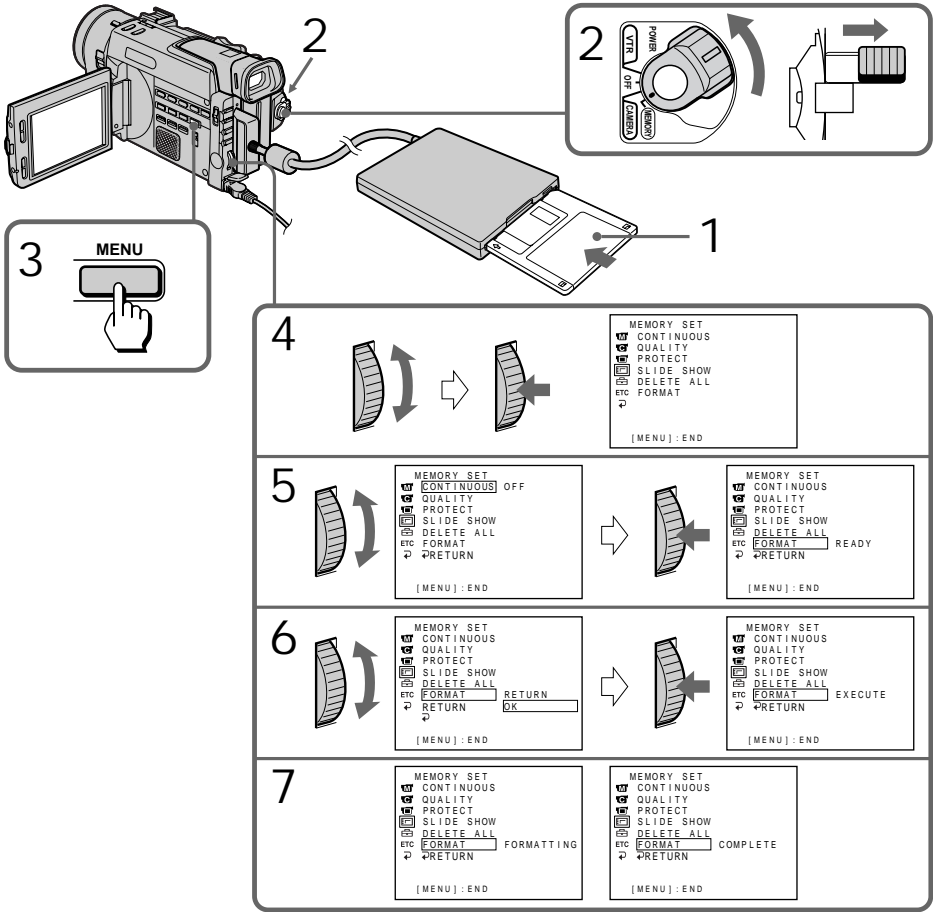

Memory card slot operations

Notes on formatting

- Formatting erases all information on the floppy disk or PC card, including the protected image data. Check the contents of the disk or PC card before formatting.
- Be sure that the battery is fully charged when formatting a floppy disk or PC card. Formatting takes about three minutes maximum.
- Do not turn the POWER switch or press any button while the display shows "FORMATTING."

Recording an image from a mini DV tape as a still image

This camcorder can read moving picture data recorded on a mini DV tape and record it as a still image on a floppy disk or a PC card. The unit can also take in moving picture data through the input connector and record it as a still image on a floppy disk or a PC card.

Before operation

- Insert a recorded mini DV tape.
- Connect the floppy disk adapter (with a disk inside) or a PC card into the unit.

- (1) Set the POWER switch to VTR.
- (2) Press \blacktriangleleft . The picture recorded on the mini DV tape is played back.
- (3) Keep pressing PHOTO lightly until a picture from the mini DV tape freezes. "CAPTURE" appears on the LCD screen or in the viewfinder. Recording does not start yet.
- (4) Press PHOTO deeper. The image displayed on the screen will be recorded on a floppy disk or a PC card. The recording is complete when the bar scroll indicator disappears.

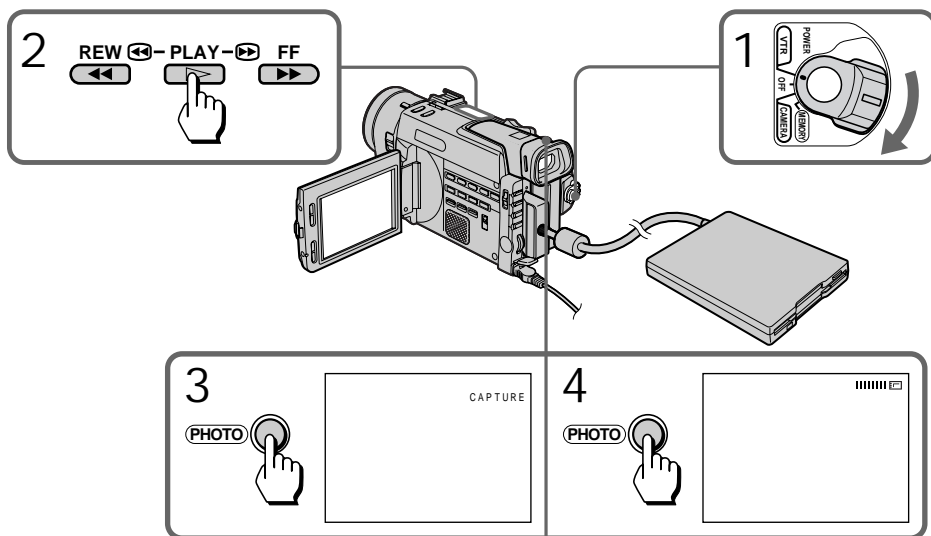

When the access lamp is flashing

Never shake or strike the unit. As well do not turn the power off, eject a PC card/floppy disk adapter or remove the battery pack. Otherwise, the image data breakdown may occur.

If "MEMORY FULL" appears on the LCD screen or in the viewfinder
The memory of the PC card or floppy disk is full.

If "CHECK MEMORY" appears on the LCD screen or in the viewfinder
An incompatible PC card or floppy disk is inserted. Be sure to use proper card or disk.

Recording an image from a mini DV tape as a still image

Recording a still image from a mini DV tape right after turning on the power
Saving the data may take a little more time than usual. This is not a malfunction.

Sound recorded on a mini DV tape
You cannot record the audio from a mini DV tape.

About titles recorded on the mini DV tape
You cannot record titles. The title is not displayed during recording.

Recording a still image from other equipment

When recording the image through the  DV IN/OUT jack

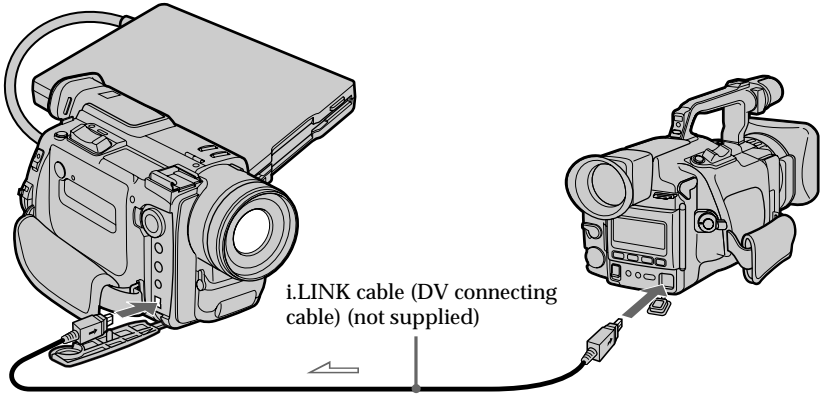

When recording the image through the AUDIO/VIDEO jack

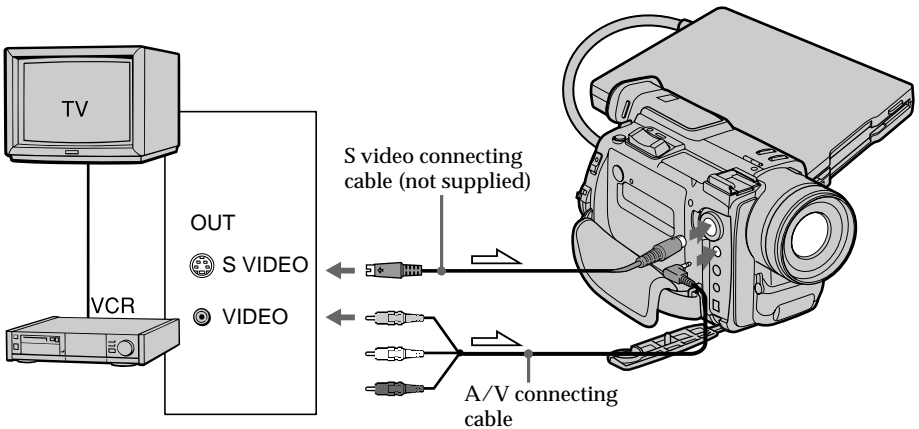

- (1) Set the POWER switch to VTR and set DISPLAY to LCD in the menu system.
- (2) Play back the recorded tape, or turn the TV on to see the desired program.
- (3) Follow the steps 3 and 4 on page 98.

Copying still images from a mini DV tape – photo save

Using the search function, you can automatically take in only the still images from mini DV tapes and record them on a floppy disk or a PC card in sequence.

Before operation

- Insert a recorded mini DV tape and rewind the tape.
- Connect the floppy disk adapter (with a disk inside) or insert a PC card into the unit.

- (1) Set the POWER switch to VTR.
- (2) Press MENU to display the menu.
- (3) Turn the control dial to select , then press the dial.
- (4) Turn the control dial to select PHOTO SAVE, then press the dial. “PHOTO BUTTON” appears on the LCD screen or in the viewfinder.
- (5) Press PHOTO deeper. The still image from the mini DV tape is recorded on a floppy disk or PC card. The number of still images copied is displayed. “END” is displayed when copying is completed.

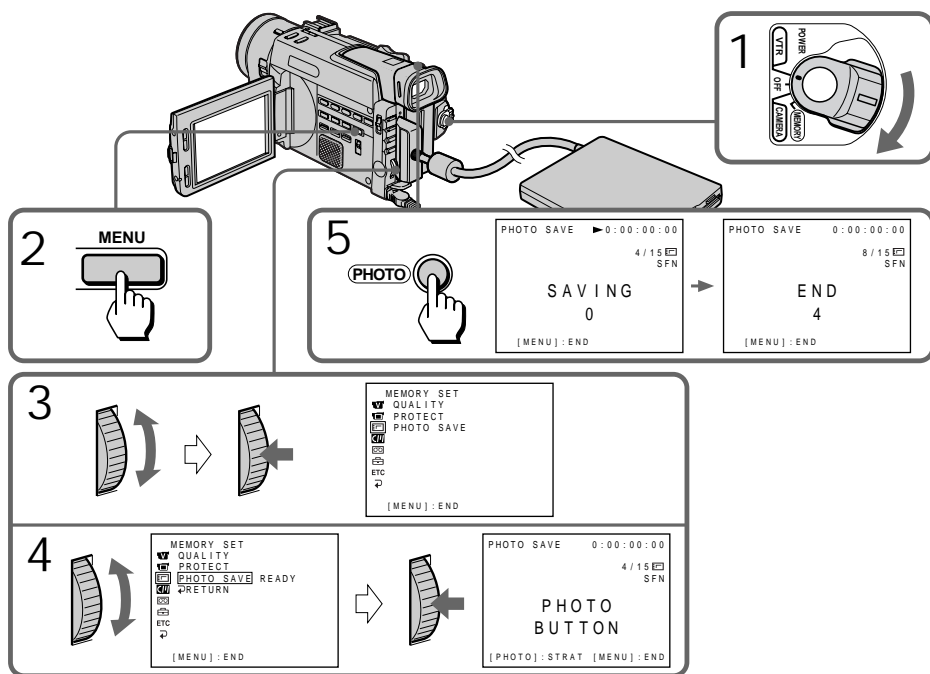

To cancel copying
Press MENU to stop copying.

When the memory of the floppy disk or PC card is full
“MEMORY FULL” appears on the screen, and the copying stops. Insert another floppy disk or PC card and repeat the procedure from step 1.

Copying still images from a mini DV tape – photo save

When the access lamp is flashing

Never shake or strike the unit. As well do not turn the power off, eject a PC card/floppy disk adapter or remove the battery pack. Otherwise, the image data breakdown may occur.

To record all the images recorded on the mini DV tape

Rewind the tape all the way and start copying.

When you change floppy disks in the middle of copying

The unit resumes copying from the last image recorded on the previous disk.

Recording still images on PC cards (not supplied) – memory photo recording

You can record still images with all the pixels (progressive) on an optional PC card.

Before operation

Insert a PC card into the unit.

- (1) Set the POWER switch to MEMORY. Make sure that the lock knob is set to the right (unlock) position.
- (2) Keep pressing PHOTO lightly. A picture freezes and “CAPTURE” appears on the LCD screen or in the viewfinder. Recording does not start yet.
- (3) Press PHOTO deeper. The image displayed on the screen will be recorded on a PC card. The recording is complete when the bar scroll indicator disappears.

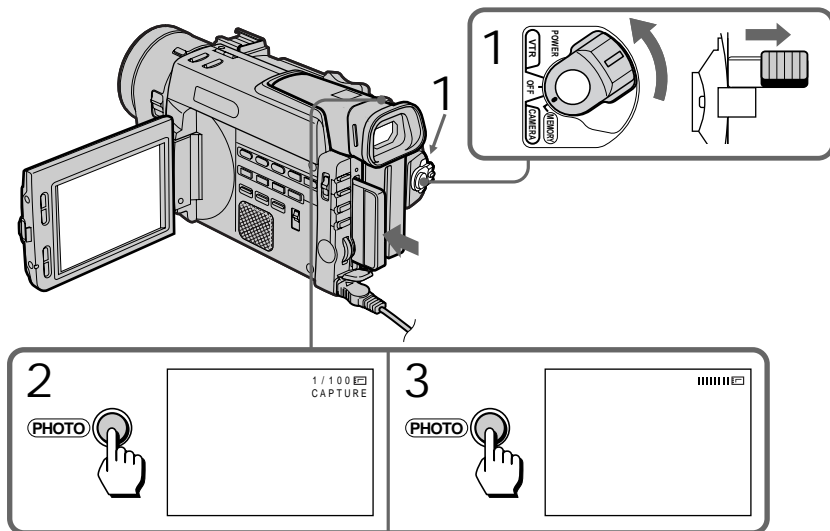

When the POWER switch is set to MEMORY

The following functions do not work:

digital zoom (more than 12x), wide TV mode, digital effect, picture effect, title.

When you are recording a still image

You can neither turn off the power nor press PHOTO.

When you press the PHOTO button on the Remote Commander

The camcorder immediately records the image that is on the screen when you press the button.

When using a video light (not supplied) or similar equipment mounted on the intelligent accessory shoe

Recording an image on a PC card may result in a temporary power shortage in the accessory shoe, causing the video light to go out. This is not a malfunction.

Recording images continuously

You can shoot continuously by selecting one of two modes described below.

Continuous mode [a]

You can record from 2 to 4 pictures continuously.

Multi screen mode [b]

You can record 9 still pictures continuously on a single page.

[a]



[b]



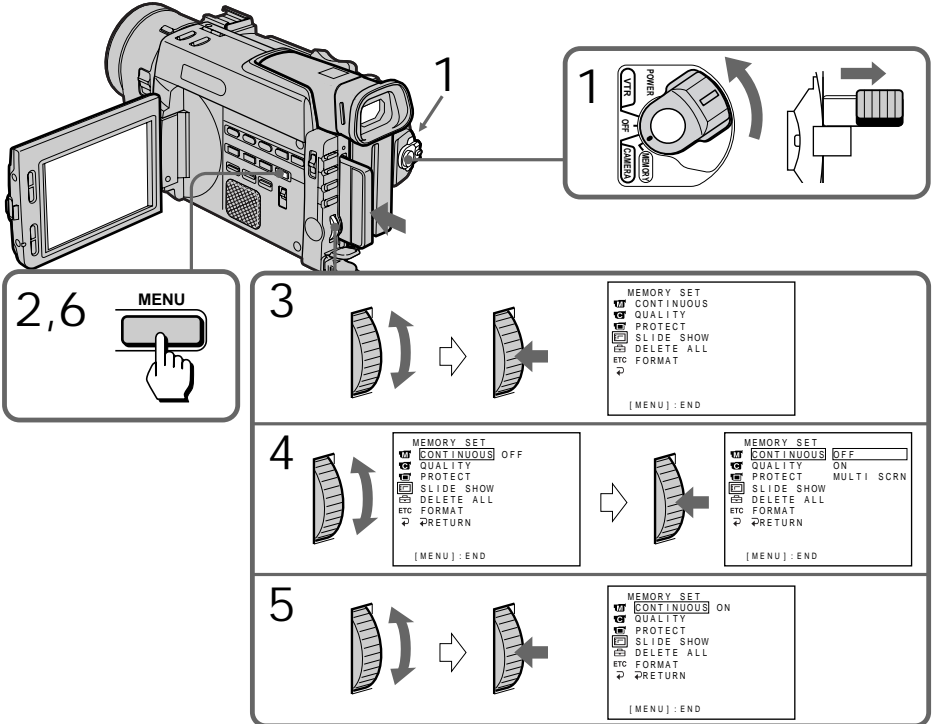

Recording still images on PC cards (not supplied) – memory photo recording

- (1) Set the POWER switch to MEMORY. Make sure that the lock knob is set to the right (unlock) position.
- (2) Press MENU to display the menu.
- (3) Turn the control dial to select , then press the dial.
- (4) Turn the control dial to select CONTINUOUS, then press the dial.
- (5) Turn the control dial to select the desired setting, then press the dial.
- (6) Press MENU to erase the menu display.



Settings of continuous shooting

Setting	Meaning (indicator on the screen)
OFF	The unit shoots one image at a time. (no indicator)
ON	The unit shoots 2 to 4 still images at about 0.8 sec intervals. ()
MULTI SCR	The unit shoots 9 still images at about 0.3 sec intervals and displays the images on a single page divided into 9 boxes. ()

The number of images in continuous shooting

The number of images you can shoot continuously varies depending on the image quality mode.

SUPER FINE: 2 images

FINE: 3 images

STANDARD: 4 images

Note on using the video flash light (not supplied)

The video flash light does not work in the continuous or multi screen mode if you install it to the accessory shoe.

Viewing a still picture – memory photo playback

You can play back still images recorded on a floppy disk or PC card. You can also play back 6 images at a time by selecting the index screen.

Before operation

Connect the floppy disk adapter (with a disk inside) or insert a PC card into the unit.

- (1) Set the POWER switch to MEMORY. Make sure that the lock knob is set to the right (unlock) position.
- (2) While pressing OPEN, open the LCD panel.
- (3) Press MEMORY PLAY. The last recorded image is displayed.
- (4) Press MEMORY +/- to select the desired still image. To see the previous image, press MEMORY -. To see the next image, press MEMORY +.

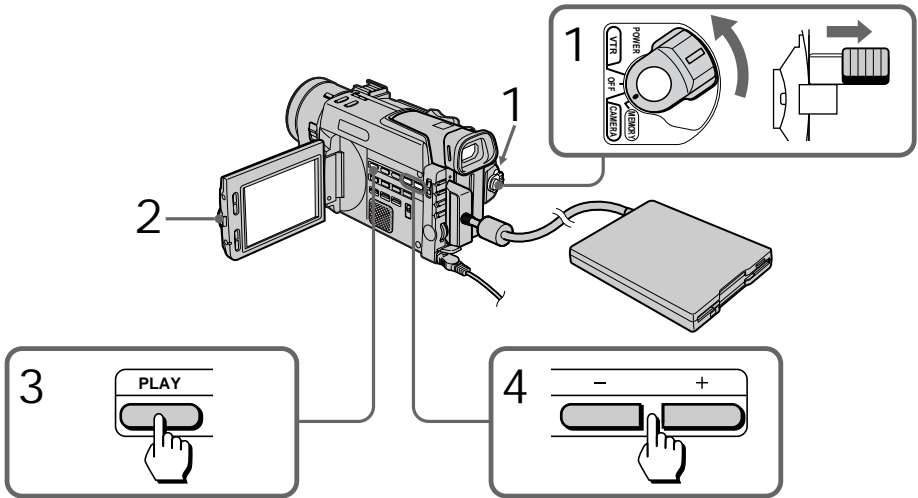

To stop memory photo playback

Press MEMORY PLAY again. Otherwise, the image through the lens will not appear on the screen.

To play back recorded images on a TV screen

- Connect this camcorder to the TV with the supplied A/V connecting cable before operation. You cannot play back images using the LASER LINK function.
- When operating memory photo playback on a TV or the LCD screen, the image quality may appear to have deteriorated. This is not a malfunction. The image data is as good as ever.
- Turn the audio volume of the TV down before operation, or there may be noise (howling) coming from the TV speakers.

Image data modified with personal computers or shot with other equipment
You may not be able to play them back with this camcorder.

Viewing a still picture – memory photo playback

Screen indicators during still image playback

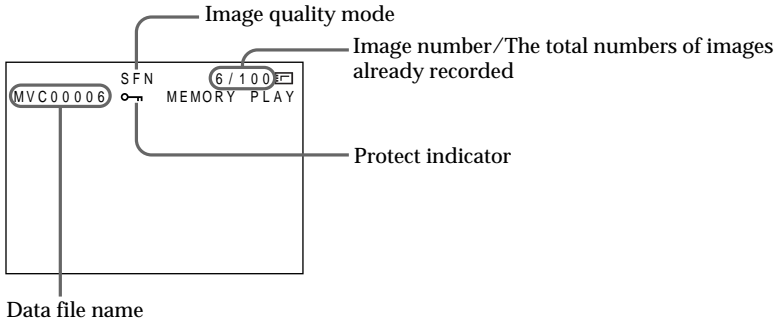

Playing back 6 recorded images at a time (index screen)

You can play back 6 recorded images at a time. This function is especially useful when searching for a particular image.

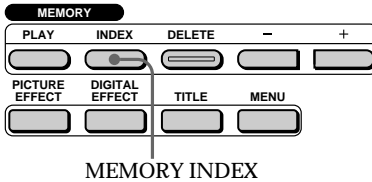

Press MEMORY INDEX.

A red ► mark appears above the image that is displayed before changing to index screen mode.

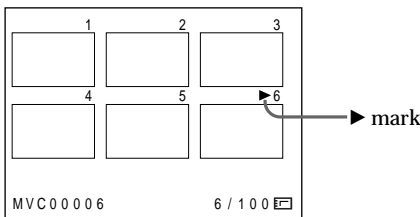

- To display the following 6 images, keep pressing MEMORY +.
- To display the previous 6 images, keep pressing MEMORY -.

To return to the normal playback screen (single screen)

Press MEMORY +/- to move the ► mark to the image you want to display on full screen, then press MEMORY PLAY.

Note

When displaying the index screen, the number appears above each image. This indicates the recording order on the floppy disk or PC card. These numbers are different from the data file names.

The image quality mode indicator

The indicator may show a different mode in which you recorded. This is not a malfunction. The indicator shows the volume of the data file. For instance, if the volume of SFN image is small enough, it may be displayed as FIN or STD.

Image data modified with personal computers or shot with other equipment
Those image data cannot be displayed on the index screen.

Viewing the recorded images using a personal computer

The image data recorded with this camcorder is compressed in the JPEG format. If your personal computer has an application software that allows you to see JPEG images, you can see images recorded on a floppy disk or PC card on a computer screen. For detailed instructions on operation, refer to the operating instruction supplied with the application software.

Example: Operation on a computer that has Windows 95 installed

- (1) Start the Windows 95, and insert the floppy disk into the disk drive of your computer.
- (2) Open “My Computer,” and double-click on “3.5 inch FD.”
- (3) Double-click on the file of the desired image.

Examples of recommended OS/application software

OS

- Windows 3.1
- Windows 95
- Windows NT3.51 or newer versions, etc.

Application

- Microsoft Internet Explorer, etc.

Notes



- For Macintosh, you can use the floppy disk recorded with this camcorder using the PC Exchange with Mac OS system 7.5 or higher. A viewing application for Macintosh is also necessary for viewing images.
- When you see images recorded with the camcorder on a personal computer, the display may show lines on the edge of the screen, depending on the status of video input signals at the moment. This is not a malfunction.

Preventing accidental erasure – PROTECT

To prevent accidental erasure of important images, you can protect selected images.

Before operation

Connect the floppy disk adapter (with a disk inside) or insert a PC card into the unit.

- (1) Display the image you want to protect.
- (2) Press MENU to display the menu.
- (3) Turn the control dial to select , then press the dial.
- (4) Turn the control dial to select PROTECT, then press the dial.
- (5) Turn the control dial to select ON, then press the dial.
- (6) Press MENU to erase the menu. The “” mark is displayed beside the data file name of the protected image.

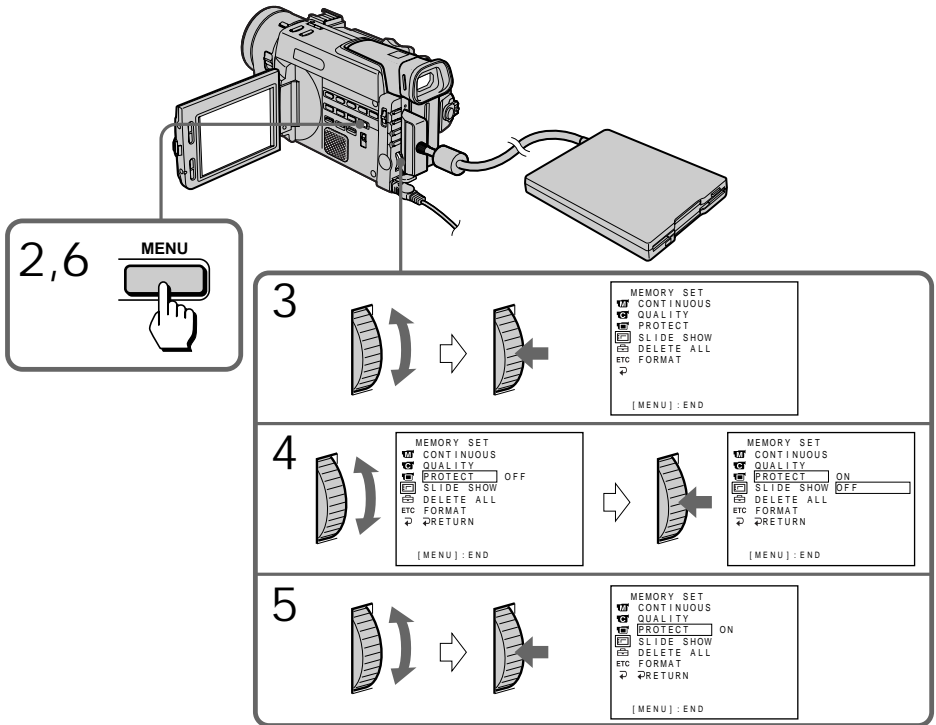

To cancel protection of the image
Select OFF in step 5, then press the control dial.

Note

Formatting erases all information on the floppy disk, including the protected image data.
Check the contents of the disk before formatting.

Deleting images

Deleting selected image

Before operation

Connect the floppy disk adapter (with a disk inside) or insert a PC card into the unit.

- (1) Display the image you want to erase.
- (2) Press MEMORY DELETE. "DELETE?" appears on the LCD screen.
- (3) Press MEMORY DELETE again. The selected image is deleted.

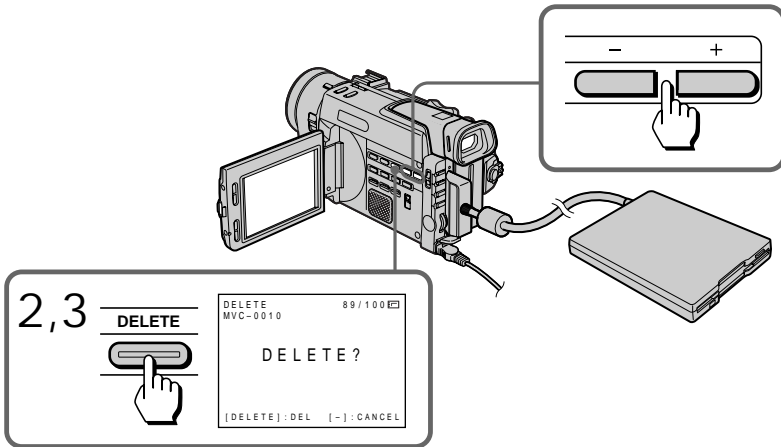

To cancel deleting an image

Press MEMORY - in step 3.

To delete an image displayed on the index screen

Press MEMORY +/- to move the ► indicator to the desired image and follow steps 2 and 3.

Notes

- To delete protected image, cancel their protection first.
- Once you delete an image, you cannot restore it. Check the images to delete carefully before deleting them.

Erasing all the images

You can delete all the unprotected images in a floppy disk or PC card.

Before operation

Connect the floppy disk adapter (with a disk inside) or insert a PC card into the unit.

- (1) Set the POWER switch to MEMORY. Make sure that the lock knob is set to the right (unlock) position.
- (2) Press MENU to display the menu.
- (3) Turn the control dial to select , then press the dial.
- (4) Turn the control dial to select DELETE ALL, then press the dial.
- (5) Turn the control dial to select OK, then press the dial. "OK" changes to "EXECUTE."
- (6) Turn the control dial to select EXECUTE, then press the dial. "DELETING" appears on the LCD screen. When all the unprotected images are deleted, "COMPLETE" is displayed.

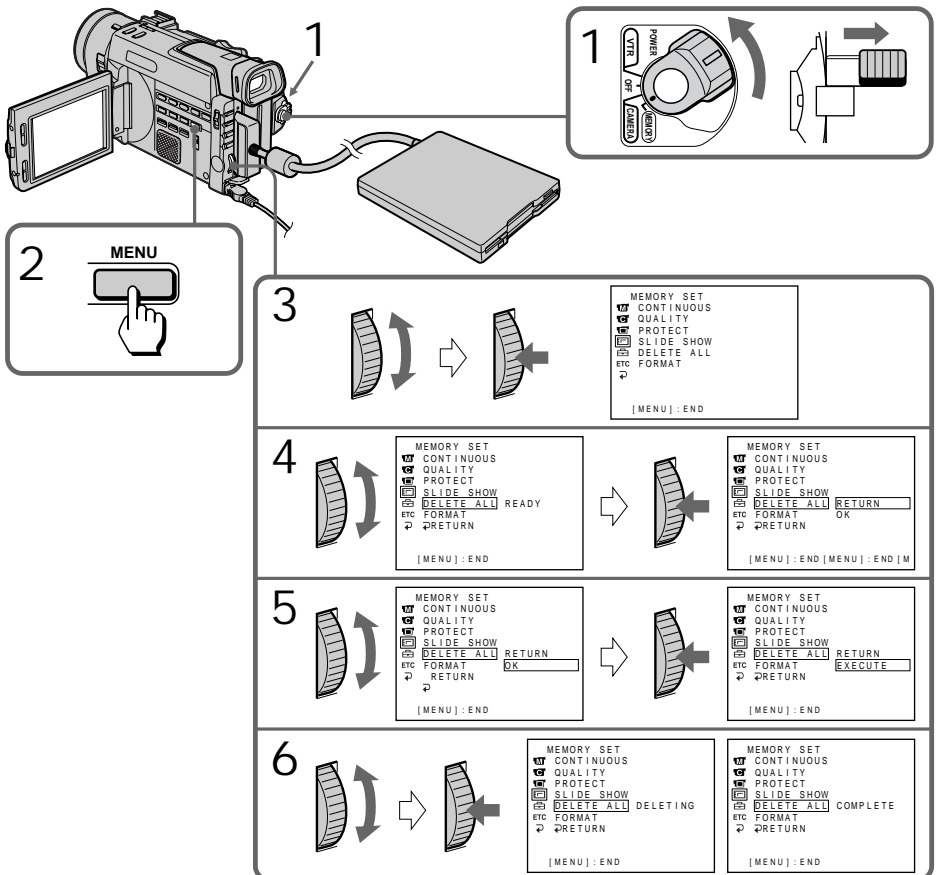

Deleting images

To cancel deleting all the images on the disk
Select \Rightarrow RETURN in step 4, then press the control dial.

While "DELETING" appears

Do not turn the POWER switch or press any buttons.

Copying the image recorded with the memory card slot to mini DV tapes

You can copy still images or titles recorded with the memory card slot and record them to a mini DV tape.

Before operation

- Insert a mini DV tape for recording.
- Connect the floppy disk adapter (with a disk inside) or insert a PC card into the unit.

- (1) Set the POWER switch to VTR.
- (2) Using the tape transport buttons, search a point where you want to record the desired still image. Set the mini DV tape to playback pause mode.
- (3) Press ● REC to set the mini DV tape to recording pause mode.
- (4) Play back the still image you want to copy.
- (5) Press ■■ to start recording and press ■■ again to stop.
- (6) If you have more to copy, repeat steps 4 and 5.

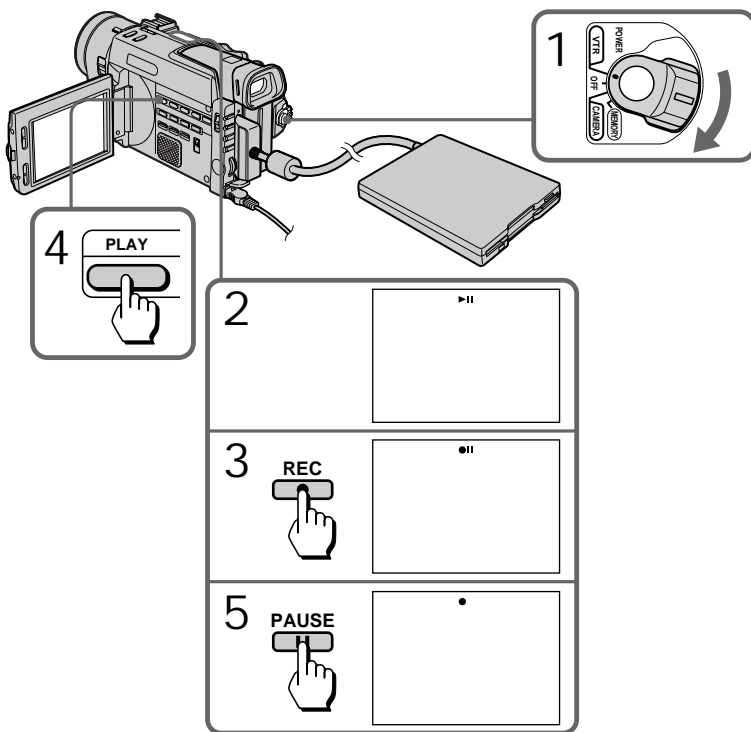

To stop copying in the middle
Press □.

During copying

You cannot operate the following buttons:

MEMORY PLAY, MEMORY INDEX, MEMORY DELETE, MEMORY +, and MEMORY -.

Note on the index screen
You cannot record the index screen.

If you press the EDITSEARCH buttons during pause mode
Memory playback stops.

If you press the DISPLAY button in Standby or Recording mode
You can see memory playback and the file name indicators in addition to the indicators pertinent to mini DV tapes, such as the time code indicator.

Image data modified with personal computers or shot with other equipment
You may not be able to make copies of those data.

Playing back images in a continuous loop – SLIDE SHOW

You can automatically play back images in sequence. This function is useful especially when checking the recorded images or during a presentation.

Before operation

Connect the floppy disk adapter (with a disk inside) or insert a PC card into the unit.

- (1) Set the POWER switch to MEMORY. Make sure that the lock knob is set to the right (unlock) position.
- (2) Press MENU to display the menu.
- (3) Turn the control dial to select , then press the dial.
- (4) Turn the control dial to select SLIDE SHOW, then press the dial.
- (5) Press MEMORY PLAY. The unit plays back the images recorded on a floppy disk or PC card in sequence. When all the images have been played back, the display shows the first image again and the slide show ends.

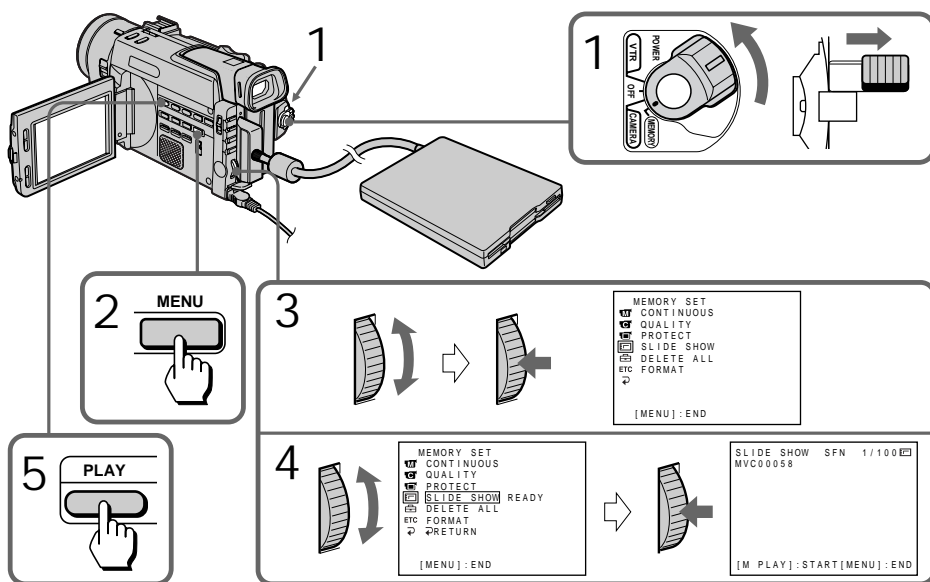

To cancel the slide show
Press MENU to stop the slide show.

To pause during a slide show
Press MEMORY PLAY to set it in a pause.

To start the slide show from a particular image
Select the desired image using MEMORY +/- buttons before step 2.

To view the recorded images on TV
Connect this camcorder to a TV with the supplied A/V connecting cable before operation.
You cannot play back the images using the LASER LINK function.

Playing back images in a continuous loop – SLIDE SHOW

Note on the slide show

You cannot make copy of the slide show on a mini DV tape.

If you change the floppy disk during operation

The slide show does not operate. If you change the disk, be sure to follow the steps again from the beginning.

Usable cassettes and playback modes

Selecting cassette types

You can use the **Mini DV** mini DV cassette only. You cannot use any other **DV** DV, **8 mm**, **Hi8** Hi8, **VHS** VHS, **S-VHS** S-VHS, **VHS-C** VHSC, **S-VHS-C** S-VHSC, or **B** Betamax cassette.

We recommend mini DV cassette with cassette memory.

There are two types of mini DV cassettes: with cassette memory and without cassette memory. We recommend you to use the tape with cassette memory. The IC memory is mounted on this type of mini DV cassette. This camcorder can read and write data such as dates of recording or titles, etc. to this memory. The functions using the cassette memory require successive signals recorded on the tape. If the tape has a blank portion in the beginning or between the recorded portions, a title may not be displayed properly or the search functions may not work properly. Not to make any blank portion on the tape, operate the following.

Press **END SEARCH** to go to the end of the recorded portion before you begin the next recording if you operate the following:

- you have ejected the cassette while recording.
- you have played back the tape in the VTR mode.
- you have used the Edit Search function.

If there is a blank portion or discontinuous signal on your tape, re-record from the beginning to the end of the tape concerning above.

The same result may occur when you record using a digital video camera recorder without a cassette memory function on a tape recorded by one with the cassette memory function.

Tapes with cassette memory have **CM** (Cassette Memory) mark. Sony recommends that you use a tape having **CM** mark to enjoy this camcorder fully.

When you play back

Copyright signal

When playing back

Using any other video camera recorder, you cannot record on a tape that has recorded a copyright control signals for copyright protection of software which is played back in this camcorder.

When recording

Using this camcorder, you cannot record software that has recorded a copyright control signals for copyright protection of software. "COPY INHIBIT" appears on the LCD screen, in the viewfinder or on the TV screen if you try to record such software.

Audio mode

12-bit mode: The original sound can be recorded in stereo 1, and the new sound in stereo 2 in 32 kHz. The balance between stereo 1 and stereo 2 can be adjusted by selecting **AUDIO MIX** in the menu system during playback. Both sounds can be played back.

16-bit mode: A new sound cannot be recorded but the original sound can be recorded in high quality. Moreover, it can also play back sound recorded in 32 kHz, 44.1 kHz or 48 kHz. When playing back a tape recorded in the 16-bit mode, **16BIT** indicator appears on the LCD screen or in the viewfinder.

Notes on the mini DV cassette

To prevent accidental erasure

Slide out the protect tab on the cassette so that the red portion is visible. [a]

When affixing a label on the mini DV cassette

Be sure to affix a label only on the locations as illustrated below so as not to cause malfunction of the camcorder. [b]

After using the mini DV cassette

Rewind the tape to the beginning, put the cassette in its case, and store it in an upright position.

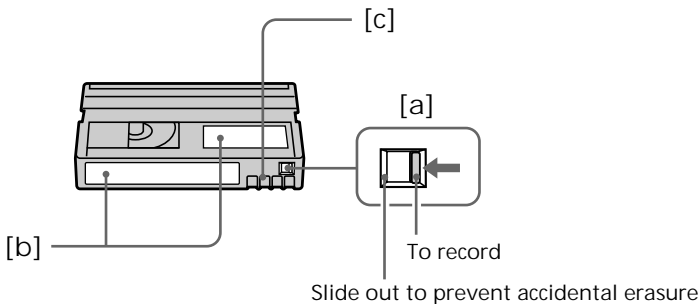

Note on gold-plated connector

If the gold-plated connector of mini DV cassettes is dirty or dusty, you may not operate the function using cassette memory. Clean up the gold-plated connector with cotton-wool swab, about every 10 times ejection of a cassette. [c]

Charging the vanadium-lithium battery in the camcorder

Your camcorder is supplied with a vanadium-lithium battery installed so as to retain the date and time, etc., regardless of the setting of the POWER switch. The vanadium-lithium battery is always charged as long as you are using the camcorder. The battery, however, will get discharged gradually if you do not use the camcorder. It will be completely discharged in about a year if you do not use the camcorder at all. Even if the vanadium-lithium battery is not charged, it will not affect the camcorder operation. To retain the date and time, etc., charge the battery if the battery is discharged. The following are charging methods:

- Connect the camcorder to house current using the supplied AC power adaptor, and leave the camcorder with the POWER switch turned off for more than 24 hours.
- Or install the fully charged battery pack in the camcorder, and leave the camcorder with the POWER switch turned off for more than 24 hours.

Resetting the date and time

The date and time are set at the factory. Set the time according to the local time in your country. If you do not use the camcorder for about a year, the date and time settings may be released (bars may appear) because the vanadium-lithium battery installed in the camcorder will have been discharged. In this case, first charge the vanadium-lithium battery, then reset the date and time.

- (1) Set the POWER switch to CAMERA.
- (2) Press MENU to display the menu.
- (3) Turn the control dial to select , then press the dial.
- (4) Turn the control dial to select CLOCK SET, then press the dial.
- (5) Turn the control dial to adjust the year, then press the dial.
- (6) Set the month, day, hour and minutes by turning and pressing the control dial.
- (7) Press MENU to erase the menu display.

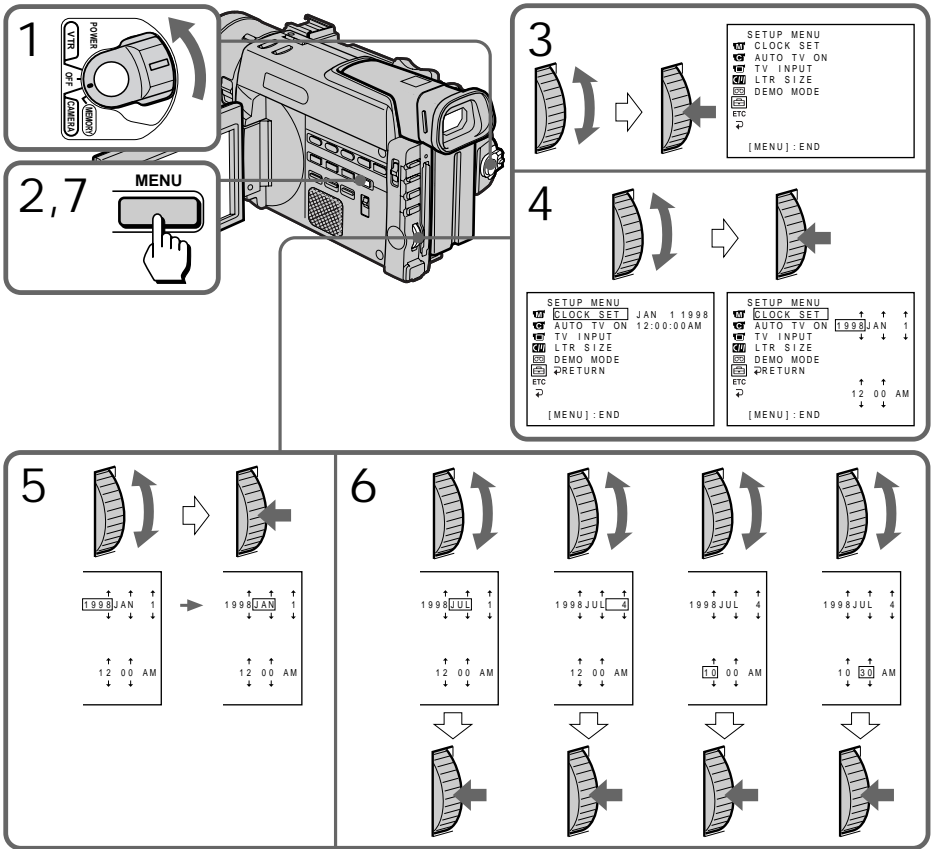

Resetting the date and time

To correct the date and time setting

Repeat steps 2 to 5.

If you do not set the date and time

"--:--:--" is recorded on the tape and "80.1.1" on the PC card or floppy disk.

The year indicator changes as follows:

→ 1998 → 1999 → 2001 → 2029 →

Note on the time indicator

The internal clock of this camcorder operates on a 12-hour cycle.

- 12:00 AM stands for midnight.
- 12:00 PM stands for noon.

Simple setting of clock by time difference

You can easily set the clock for a local time by a time difference in the menu system.

You can also reset the clock simply by setting the time difference to zero.

- (1) While the camcorder is in Standby mode, press MENU to display the menu.
- (2) Turn the control dial to select **ETC**, then press the dial.
- (3) Turn the control dial to select **WORLD TIME**, then press the dial.
- (4) Turn the control dial to set a time difference, and press the dial. The hour of clock changes in relation to a time difference which you set.
- (5) Press MENU to erase the menu display.

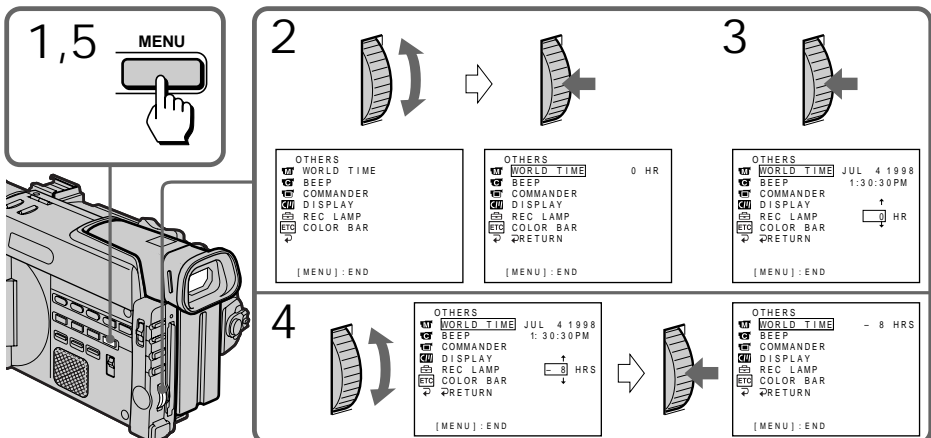

Note on WORLD TIME

If the clock is not set, WORLD TIME does not work.

Tips for using the battery pack

This section shows you how you can get the most out of your battery pack.

Preparing the battery pack

Always carry additional batteries

Have sufficient battery pack power to do 2 to 3 times as much recording as you have planned.

Battery life is shorter in a cold environment

Battery efficiency is decreased, and the battery will be used up more quickly, if you are recording in a cold environment.

To save battery power

Do not leave the camcorder in Standby mode when not recording to save the battery power. A smooth transition between scenes can be made even if recording is stopped and started again. While you are positioning the subject, selecting an angle, or looking at the LCD screen or through the viewfinder, the lens moves automatically and the battery is used. The battery is also used when a tape is inserted or removed.

When to replace the battery pack

While you are using your camcorder, the remaining battery indicator on the LCD screen or in the viewfinder decreases gradually as battery power is used up.

The remaining time in minutes also appears.



When the remaining battery indicator reaches the lowest point, the  indicator appears and starts flashing on the LCD screen or in the viewfinder.

When the  indicator on the LCD screen or in the viewfinder changes from slow flashing to rapid flashing while you are recording, set the POWER switch to OFF on the camcorder and replace the battery pack. Leave the tape in the camcorder to obtain a smooth transition between scenes after the battery pack has been replaced.

Notes on the rechargeable battery pack

Caution

Never leave the battery pack in temperatures above 60°C, such as in a car parked in the sun or under direct sunlight.

The battery pack heats up

During charging or recording, the battery pack heats up. This is caused by energy that has been generated and a chemical change that has occurred inside the battery pack. This is not cause for concern, and is normal.

Battery pack care

- Remove the battery pack from the camcorder after using it, and keep it in a cool place. When the battery pack is installed to the camcorder, a small amount of current flows to the camcorder even if the POWER switch is set to OFF. This shortens battery life.
- The battery pack is always discharging even when it is not in use after charging. Therefore, you should charge the battery pack right before using the camcorder.

The life of the battery pack

If the battery indicator flashes rapidly just after turning on the camcorder with a fully charged battery pack, the battery pack should be replaced with a new fully charged one.

Charging temperature

You should charge batteries at temperatures from 10°C to 30°C. Lower temperatures require a longer charging time.

Notes on the "InfoLITHIUM" Battery Pack

What is the "InfoLITHIUM" battery pack

The "InfoLITHIUM" battery pack is a lithium battery pack which can exchange data with compatible video equipment about its battery consumption.

When you use this battery pack with video equipment having the  InfoLITHIUM mark, the video equipment will indicate the remaining battery time in minutes.*

* The indication may not be accurate depending on the condition and environment which the equipment is used under.

How the battery consumption is displayed



The power consumption of the camcorder changes depending on its use, such as whether the LCD panel is used or not, how the autofocus is working on or not.

While checking the condition of the camcorder, the "InfoLITHIUM" battery pack measures the battery consumption and calculates the remaining battery power. If the condition changes drastically, the remaining battery indication may suddenly decrease or increase by more than 2 minutes.

Even if 5 to 10 minutes is indicated as the battery remaining time on the LCD screen or in the viewfinder, the  indicator may also flash under some conditions.

To obtain more accurate remaining battery indication

Set the camcorder to recording standby mode and point towards a stationary object. Do not move the camcorder for 30 seconds or more.

- If the indication seems incorrect, use up the battery and then recharge it fully (Full charge¹⁾). Note that if you have used the battery in a hot or cold environment for long time, or you have repeated charging many times, the battery may not be able to show the correct time even after being fully charged.
- After you have used the "InfoLITHIUM" battery pack with an equipment not having the  InfoLITHIUM mark, make sure that you use up the battery on the equipment having the  InfoLITHIUM mark and then recharge fully.

Why the remaining battery indication does not match the continuous recording time in the operating instruction

The recording time is affected by the environmental temperature and conditions. The recording time becomes very short in a cold environment. The continuous recording time in the operating instruction is measured under the condition of using a fully charged (or normal charged²⁾) battery pack in 25 °C. As the environmental temperature and condition are different when you actually use the camcorder, the remaining battery time is not same as the continuous recording time in the operating instruction.

¹⁾ Full charge: Charging for about 1 hour after the charge lamp of the AC power adaptor goes off.

²⁾ Normal charge: Charging just until the charge lamp of the AC power adaptor goes off.

Notes on charging

A brand-new battery pack

A brand-new battery pack is not charged. Before using the battery pack, charge it completely.

Recharge the battery pack whenever you like

You do not have to discharge it before recharging. If you charged the battery pack fully but you did not use it for a long time, it becomes discharged. Then recharge the battery pack before use.

Notes on the terminals

If the terminals (metal parts on the back) are not clean, the battery charge duration will be shortened

When the terminals are not clean or when the battery pack has not been used for a long time, repeatedly install and remove the battery pack a few times. This improves the contact condition. Also, wipe the +, - and C terminals with a soft cloth or paper.

Be sure to observe the following



- Keep the battery pack away from fire.
- Keep the battery pack dry.
- Do not open nor try to disassemble the battery pack.
- Do not expose the battery pack to any mechanical shock.

Maintenance information and precautions

Moisture condensation

If the camcorder is brought directly from a cold place to a warm place, moisture may condense inside the camcorder, on the surface of the tape, on the lens, on the head, or on the floppy disk. In this condition, the tape may stick to the head drum and be damaged or the camcorder may not operate correctly. To prevent possible damage under these circumstances, the camcorder is furnished with moisture sensors. Take the following precautions.

Inside the camcorder

If there is moisture inside the camcorder, the beep sounds and the  indicator flashes. Eject the cassette or the floppy disk immediately. If this happens, none of the function except cassette ejection will work. Open the cassette compartment, turn off the camcorder, and leave it about 1 hour. When  indicator flashes at the same time, the cassette is inserted in the camcorder. Eject the cassette, turn off the camcorder, and leave also the cassette about 1 hour.

On the lens

If moisture condenses on the lens, no indicator appears, but the picture becomes dim. Turn off the power and do not use the camcorder for about 1 hour.

How to prevent moisture condensation



When bringing the camcorder from a cold place to a warm place, put the camcorder in a plastic bag and allow it to adapt to room conditions over a period of time.

- (1) Be sure to tightly seal the plastic bag containing the camcorder.
- (2) Remove the bag when the air temperature inside it has reached the temperature surrounding it (after about 1 hour).

Video head cleaning

To ensure normal recording and clear pictures, clean the video heads.

The video heads may be dirty when:

- mosaic-pattern noise appears on the playback picture
- playback pictures do not move
- playback pictures are hardly visible
- playback pictures do not appear
- the  indicator and “ CLEANING CASSETTE” message appear one after another or the  indicator flashes on the LCD screen or in the viewfinder.

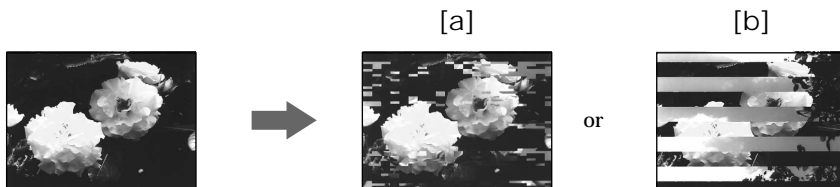

If [a] or [b] happens, clean the video heads with the Sony DVM12CL cleaning cassette (not supplied). Check the picture and if the above problem persists, repeat the cleaning. (Do not repeat cleaning more than 5 times in one session.)

Note

If the DVM12CL cleaning cassette (not supplied) is not available in your area, consult your nearest Sony dealer.

Precautions

Camcorder operation

- Operate the camcorder on 7.2 V (battery pack) or 8.4 V (AC power adaptor).
- Should any solid object or liquid get inside the casing, unplug the camcorder and have it checked by Sony dealer before operating it any further.
- Avoid rough handling or mechanical shock. Be particularly careful of the lens.
- Keep the POWER switch set to OFF when not using the camcorder.
- Do not wrap up the camcorder and operate it since heat may build up internally.
- Keep the camcorder away from strong magnetic fields or mechanical vibration.

On handling tapes

- Do not insert anything in the small holes on the cassette.
- Do not open the tape protect cover or touch the tape.
- Avoid touching or damaging the terminals. To remove dust, clean the terminals with a soft cloth.

Camcorder care

- When the camcorder is not to be used for a long time, disconnect the power source and remove the tape. Periodically turn on the power, operate the camera and player sections and play back a tape for about 3 minutes.
- Clean the lens with a soft brush to remove dust. If there are fingerprints on the lens, remove them with a soft cloth.
- Clean the camcorder body with a dry soft cloth, or a soft cloth lightly moistened with a mild detergent solution. Do not use any type of solvent which may damage the finish.
- Do not let sand get into the camcorder. When you use the camcorder on a sandy beach or in a dusty place, protect it from the sand or dust. Sand or dust may cause the unit to malfunction, and sometimes this malfunction cannot be repaired.

AC power adaptor

Charging

- Use only an “InfoLITHIUM” type battery pack.
- Place the battery pack on a flat surface without vibration during charging.
- The battery pack will get hot during charging. This is normal.

Others

- Unplug the unit from the wall outlet when not in use for a long time. To disconnect the power cord, pull it out by the plug. Never pull the cord itself.
- Do not operate the unit with a damaged cord or if the unit has been dropped or damaged.
- Do not bend the AC power cord forcibly, or put a heavy object on it. This will damage the cord and may cause a fire or an electrical shock.
- Be sure that nothing metallic comes into contact with the metal parts of the connecting plate. If this happens, a short may occur and the unit may be damaged.
- Always keep the metal contacts clean.
- Do not disassemble the unit.
- Do not apply mechanical shock or drop the unit.
- While the unit is in use, particularly during charging, keep it away from AM receivers and video equipment because it will disturb AM reception and video operation.
- The unit becomes warm while in use. This is normal.
- Do not place the unit in locations that are:
Extremely hot or cold, Dusty or dirty, Very humid, Vibrating

Note on dry batteries

To avoid possible damage from battery leakage or corrosion, observe the following.

- Be sure to insert the batteries in the correct direction.
- Dry batteries are not rechargeable.
- Do not use a combination of new and old batteries.
- Do not use different types of batteries.
- The batteries slowly discharge while not in use.
- Do not use a battery that is leaking.

If battery leakage occurred

- Wipe off the liquid in the battery case carefully before replacing the batteries.
- If you touch the liquid, wash it off with water.
- If the liquid get into your eyes, wash your eyes with a lot of water and then consult a doctor.

If any difficulty should arise, unplug the unit and contact your nearest Sony dealer.

Using your camcorder abroad

Each country or area has its own electric and TV color systems. Before using your camcorder abroad, check the following points.

Power sources

You can use your camcorder in any country or area with the supplied AC power adaptor within 100 V to 240 V AC, 50/60 Hz.

Difference in color systems

This camcorder is an NTSC system-based camcorder. If you want to view the playback picture on a TV, it must be an NTSC system-based TV.

Check the following list.

NTSC system

Bahama Islands, Bolivia, Canada, Central America, Chile, Colombia, Ecuador, Jamaica, Japan, Korea, Mexico, Peru, Surinam, Taiwan, the Philippines, the U.S.A., Venezuela, etc.

PAL system

Australia, Austria, Belgium, Czech Republic, China, Denmark, Finland, Germany, Great Britain, Holland, Hong Kong, Italy, Kuwait, Malaysia, New Zealand, Norway, Portugal, Singapore, Slovak Republic, Spain, Sweden, Switzerland, Thailand, etc.

PAL-M system

Brazil

PAL-N system

Argentina, Paraguay, Uruguay

SECAM system

Bulgaria, France, Guiana, Hungary, Iran, Iraq, Monaco, Poland, Russia, Ukraine, etc.

Trouble check

If you run into any problem using the camcorder, use the following table to troubleshoot the problem. Should the difficulty persist, disconnect the power source and contact your Sony dealer or local authorized Sony service facility.

Camcorder

Power

Symptom	Cause and/or corrective actions
The power cannot be turned on.	<ul style="list-style-type: none">• The battery pack is not installed. → Install the battery pack. (p. 7)• The battery is dead. → Use a charged battery pack. (p. 8)• The AC power adaptor is not connected to a wall outlet. → Connect the AC power adaptor to a wall outlet. (p. 25)
The power goes off.	<ul style="list-style-type: none">• While being operated in CAMERA mode, the camcorder has been in Standby mode for more than 5 minutes. → Set the POWER switch to OFF, then to CAMERA. (p. 12)• The battery is dead. → Use a charged battery pack. (p. 8)
The battery pack is quickly discharged.	<ul style="list-style-type: none">• The ambient temperature is too low. (p. 120)• The battery pack has not been charged fully. → Charge the battery pack again. (p. 8)• The battery pack is completely dead, and cannot be recharged. → Use another battery pack. (p. 25)

Operation

Symptom	Cause and/or corrective actions
START/STOP does not operate.	<ul style="list-style-type: none">• The tape is stuck to the drum. → Eject the cassette. (p. 11)• The tape has run out. → Rewind the tape or use a new one. (p. 22)• The POWER switch is not set to CAMERA. → Set it to CAMERA. (p. 12)• The tab on the cassette is out (red). → Use a new tape or slide the tab. (p. 11)• The START/STOP MODE selector is set to 5SEC or $\frac{1}{2}$ ANTI GROUND SHOOTING. → Set it to $\frac{1}{2}$. (p. 15)
The cassette cannot be removed from the holder.	<ul style="list-style-type: none">• The AC power adaptor is not connected to a wall outlet. → Connect the AC power adaptor to a wall outlet. (p. 25)• The battery is dead. → Use a charged battery pack or the AC power adaptor. (p. 8, 25)
\square and \triangle indicators flash and no function except for cassette ejection works.	<ul style="list-style-type: none">• Moisture condensation has occurred. → Remove the cassette and leave the camcorder for at least 1 hour. (p. 123)
“CLOCK SET” appears when the camcorder is turned on.	<ul style="list-style-type: none">• Reset the date and time. (p. 118)
The end search function does not work.	<ul style="list-style-type: none">• You did not make a new recording after reinserting the cassette.• The tape without cassette memory ejected after recording.

Operation

Symptom	Cause and/or corrective actions
The end search function does not work correctly.	<ul style="list-style-type: none"> The tape has a blank portion in the middle.
The tape does not move when a tape transport button is pressed.	<ul style="list-style-type: none"> The POWER switch is not set to VTR. <ul style="list-style-type: none"> → Set it to VTR. (p. 22) The tape has run out. <ul style="list-style-type: none"> → Rewind the tape or use a new one. (p. 22)
No sound or only a low sound is heard when playing back a tape.	<ul style="list-style-type: none"> The volume is turned to the minimum. <ul style="list-style-type: none"> → Open the LCD panel and press VOLUME +. (p. 22) AUDIO MIX is set to ST2 side in the menu system. <ul style="list-style-type: none"> → Adjust AUDIO MIX in the menu system. (p. 90)
The new sound added to the recorded tape is not heard.	<ul style="list-style-type: none"> AUDIO MIX is set to ST1 side in the menu system. <ul style="list-style-type: none"> → Adjust AUDIO MIX in the menu system. (p. 90)
The Steady Shot function does not work.	<ul style="list-style-type: none"> STEADYSHOT is set to OFF in the menu system. <ul style="list-style-type: none"> → Set it to ON. (p. 51)
Recording stops in a few seconds.	<ul style="list-style-type: none"> The START/STOP MODE selector is set to 5SEC or $\frac{\perp}{\perp}$ ANTI GROUND SHOOTING. <ul style="list-style-type: none"> → Set it to $\frac{\perp}{\perp}$. (p. 15)
The autofocus function does not work.	<ul style="list-style-type: none"> Focus is set to the manual mode. <ul style="list-style-type: none"> → Set it to autofocus. (p. 58) Shooting conditions are not suitable for autofocus. <ul style="list-style-type: none"> → Set focus to manual mode to focus manually. (p. 58)
The fader function does not work.	<ul style="list-style-type: none"> The START/STOP MODE selector is set to 5SEC or $\frac{\perp}{\perp}$ ANTI GROUND SHOOTING. <ul style="list-style-type: none"> → Set it to $\frac{\perp}{\perp}$. (p. 15)
The title is not displayed.	<ul style="list-style-type: none"> TITLE DSPL is set to OFF in the menu system. <ul style="list-style-type: none"> → Set it to ON in the menu system. (p. 30)
The title is not recorded.	<ul style="list-style-type: none"> The tape has no cassette memory. <ul style="list-style-type: none"> → Use a tape with cassette memory. (p. 63) The cassette memory is full. <ul style="list-style-type: none"> → Erase another title. (p. 65) The tape is set to prevent accidental erasure. <ul style="list-style-type: none"> → Slide the protect tab so that red portion is not visible. (p. 11) Nothing is recorded in that position on the tape. <ul style="list-style-type: none"> → Superimpose the title to the recorded position. (p. 63)
The cassette label is not recorded.	<ul style="list-style-type: none"> The tape has no cassette memory. <ul style="list-style-type: none"> → Use a tape with cassette memory. (p. 68) The cassette memory is full. <ul style="list-style-type: none"> → Erase some titles. (p. 65) The tape is set to prevent accidental erasure. <ul style="list-style-type: none"> → Slide the protect tab so that red portion is not visible. (p. 11)
Displaying the recorded date, date search function does not work.	<ul style="list-style-type: none"> The tape has no cassette memory. <ul style="list-style-type: none"> → Use a tape with cassette memory. (p. 74) CM SEARCH is set to OFF in the menu system. <ul style="list-style-type: none"> → Set it to ON. (p. 74)

Operation

Symptom	Cause and/or corrective actions
The title search function does not work.	<ul style="list-style-type: none"> The tape has no cassette memory. <ul style="list-style-type: none"> → Use a tape with cassette memory. (p. 76) CM SEARCH is set to OFF in the menu system. <ul style="list-style-type: none"> → Set it to ON. (p. 76) There is no title in the tape. <ul style="list-style-type: none"> → Superimpose the titles. (p. 63)
C// indicator does not appear when using a tape with cassette memory.	<ul style="list-style-type: none"> The gold-plated connector of the tape is dirty or dusty. <ul style="list-style-type: none"> → Clean the gold-plated connector. (p. 117)
The date search, title search, or end search does not work correctly.	<ul style="list-style-type: none"> The tape has a blank portion between the recorded portions. (p. 116)
The click of the shutter does not sound.	<ul style="list-style-type: none"> BEEP is set to OFF in the menu system. <ul style="list-style-type: none"> → Set it to MELODY or NORMAL. (p. 31)

Picture

Symptom	Cause and/or corrective actions
The image on the viewfinder screen is not clear.	<ul style="list-style-type: none"> The viewfinder lens is not adjusted. <ul style="list-style-type: none"> → Adjust the viewfinder lens. (p. 13)
A vertical band appears when a subject such as lights or a candle flame is shot against a dark background.	<ul style="list-style-type: none"> The contrast between the subject and background is too high. The camcorder is not malfunctioning. <ul style="list-style-type: none"> → Change locations.
The picture is “noisy” or does not appear.	<ul style="list-style-type: none"> The video heads may be dirty. <ul style="list-style-type: none"> → Clean the heads using the Sony DVM12CL (not supplied) cleaning cassette. (p. 123)
⊗ indicator flashes on the LCD screen or in the viewfinder.	<ul style="list-style-type: none"> The video heads may be dirty. <ul style="list-style-type: none"> → Clean the heads using the Sony DVM12CL (not supplied) cleaning cassette. (p. 123)
The picture is too bright or too dark on the LCD screen.	<ul style="list-style-type: none"> LCD BRIGHT is not adjusted properly. <ul style="list-style-type: none"> → Press + or - to obtain the brightness you want. (p. 16, 22)
A vertical band appears when shooting a very bright subject.	<ul style="list-style-type: none"> The camcorder is not malfunctioning.
The picture does not appear on the LCD screen or in the viewfinder.	<ul style="list-style-type: none"> Incorporated fluorescent tube is worn out. <ul style="list-style-type: none"> → Please contact your nearest Sony dealer.
The picture does not appear in the viewfinder.	<ul style="list-style-type: none"> The LCD panel is open. <ul style="list-style-type: none"> → Close the LCD panel.
An unknown picture is displayed on the LCD screen or in the viewfinder.	<ul style="list-style-type: none"> If 10 minutes elapse after you set the POWER switch to CAMERA without inserting a cassette, the camcorder automatically starts the demonstration or DEMO MODE is set to ON in the menu system. <ul style="list-style-type: none"> → Insert the cassette and the demonstration stops. You can deactivate the demonstration. (p. 142)
A display such as “C:□□:□□” appears on the LCD screen or in the viewfinder.	<ul style="list-style-type: none"> The self-diagnosis display function has been activated. <ul style="list-style-type: none"> → Check the code and diagnosis the problem by referring to the code chart. (p. 132)

Picture

Symptom	Cause and/or corrective actions
The picture seems to be in flash motion.	<ul style="list-style-type: none"> • PROG. SCAN is set to ON in the menu system, or the POWER switch is set to MEMORY. This is caused by progressive scanning (display with all the pixels) and is not a malfunction.
●●●●● is displayed on the LCD screen or in the viewfinder.	<ul style="list-style-type: none"> • The START/STOP MODE selector is set to 5SEC . → Set it to $\frac{1}{2}$. (p. 15)
Remaining tape indicator is not displayed.	<ul style="list-style-type: none"> • The $\frac{00}{00}$ REMAIN in the menu system is set to AUTO. → If the remaining tape indicator is always displayed, set it to ON.
The memory card slot does not function.	<ul style="list-style-type: none"> • The battery is dead. → Use a charged battery pack or the AC power adaptor. • The floppy disk is not inserted correctly. → Eject the floppy disk and insert it correctly. • The POWER switch is set to CAMERA. → Set it to MEMORY or VTR.
Recording does not function.	<ul style="list-style-type: none"> • The disk has already been recorded to its full capacity. → Erase unnecessary images and record again. • The floppy disk or PC card is not inserted. → Insert the disk or card. • Unusable floppy disk is inserted. → Use 2HD, 1.44MB, MS-DOS format floppy disk. • Unformatted disk is inserted. → Format the disk. • The protect tab on the floppy disk is set to protect. → Slide the tab to write.
The image cannot be deleted.	<ul style="list-style-type: none"> • The image is protected. → Cancel the protect.

Others

Symptom	Cause and / or corrective actions
While editing using the i.LINK cable (DV connecting cable), recording picture cannot be monitored.	<ul style="list-style-type: none"> • Remove the i.LINK cable (DV connecting cable), and connect it again.
The camcorder becomes warm.	<ul style="list-style-type: none"> • If the power of the camcorder is on for a long time, it becomes warm, which is not malfunction.
The supplied Remote Commander does not work.	<ul style="list-style-type: none"> • COMMANDER is set to OFF in the menu system. → Set it to ON. • Something is blocking the infrared rays. → Remove the obstacle. • The battery is not inserted with the correct polarity. → Insert the battery with the correct polarity. (p. 139) • The batteries are dead. → Insert new ones. (p. 139)

Others

Symptom	Cause and/or corrective actions
No function works though the power is on.	<ul style="list-style-type: none"> • Disconnect the power cord of the AC power adaptor or remove the battery pack, then reconnect it in about 1 minute. Turn the power on. If the functions still do not work, open the LCD panel and press the RESET button beside the speaker using a sharp-pointed object. (If you press the RESET button, all the settings including the date and time return to the default.) (p. 136)
DV synchro-editing does not function.	<ul style="list-style-type: none"> • The input selector on the VCR is not set correctly. <ul style="list-style-type: none"> → Set the selector to DV input position. If you use another DV camcorder, set the power switch to VTR. • The camcorder is connected to DV equipment of other than Sony. <ul style="list-style-type: none"> → Operate normal editing. • Setting program on a blank portion of the tape is attempted. <ul style="list-style-type: none"> → Set the program again on a recorded portion.

Self-diagnosis function

The camcorder has a self-diagnosis display. This function displays the camcorder's condition with five digits (a combination of a letter and figures) on the LCD screen or in the viewfinder. If this occurs, check the following code chart. The five-digit display informs you of the camcorder's current condition. The last two digits (indicated by □□) will differ depending on the state of the camcorder.

LCD screen/viewfinder

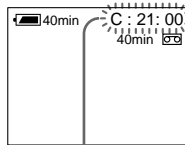

Self-diagnosis display

- C:□□:□□
You can service the camcorder yourself.
- E:□□:□□
Contact your Sony dealer or local authorized Sony facility.

Five-digit display	Cause and/or corrective actions
C:04:□□	<ul style="list-style-type: none"> • The battery other than "InfoLITHIUM" is used. → Use the "InfoLITHIUM" battery.(p. 119)
C:21:□□	<ul style="list-style-type: none"> • Moisture condensation has occurred. → Remove the cassette and leave the camcorder for at least 1 hour. (p. 123)
C:22:□□	<ul style="list-style-type: none"> • The video heads are dirty. → Clean the heads using the Sony DVM12CL cleaning cassette (not supplied). (p. 123)
C:31:□□ C:32:□□	<ul style="list-style-type: none"> • A serviceable situation not mentioned above has occurred. → Remove the cassette and insert it again, then operate the camcorder. (p. 11) → Disconnect the power cord of the AC power adaptor or remove the battery pack. After reconnecting the power source, operate the camcorder.
E:61:□□ E:62:□□	<ul style="list-style-type: none"> • A camcorder malfunction which you cannot service has occurred. → Contact your Sony dealer or local authorized Sony service facility and inform them of the five digits. (example: E:61:10)

If you are unable to resolve the problem, contact your Sony dealer or local authorized Sony service facility.

Specifications

Video camera recorder

System

Video recording system
Two rotary heads, Helical scanning system
Audio recording system
Rotary heads, PCM system
Quantization: 12bits (Fs 32kHz, stereo 1, stereo 2), 16bits (Fs 48kHz, stereo)

Video signal
NTSC color, EIA standards
Usable cassette
Mini DV cassette with logo printed
Tape speed
SP: Approx. 18.81 mm/s
LP: Approx. 12.56 mm/s
Recording/playback time
SP mode: 1 hour (DVM60)
LP mode: 1.5 hours (DVM60)
Fast forward/rewind time
Approx. 2 min. 30 s (DVM60)

Image device
3CCD (Charge Coupled Device 1/4")
Viewfinder
Electric viewfinder (color)
Lens
Combined power zoom lens, 48x (Digital), 12x (Optical)
Focal distance
f = 4.3 to 51.6 mm
(41.3 to 496 mm when converted into a 35 mm still camera)

F 1.6 - 2.8
TTL autofocus system inner focus wide macro system
Color temperature
Auto, One push, Indoor (3200K), Outdoor (5800K)
Minimum illumination
4 lux at F 1.6
Illumination range
4 to 100,000 lux
Recommended illumination
More than 100 lux

LCD screen

Picture
3.5 inches measured diagonally
72.4 x 50.4 mm
On-screen display
TN LCD/TFT active matrix method
Total dot number
184,580 (839 x 220)

Input and output connectors

S video input/output
Input/output auto switch
4-pin mini DIN

Luminance signal: 1 Vp-p, 75 ohms, unbalanced, sync negative
Chrominance signal: 0.286 Vp-p, 75 ohms, unbalanced
Audio/Video input/output
Input/output auto switch
AV MINI JACK, 1 Vp-p, 75 ohms, unbalanced, sync negative
327 mV, (at output impedance more than 47 kilohms)
Output impedance with less than 2.2 kilohms/Stereo minijack (ø 3.5mm)
Input impedance more than 47 kilohms
DV input/output
4-pin special connector
Headphones
Stereo minijack (ø 3.5 mm)
MIC input
Stereo minijack (ø 3.5mm):0.388mV, DC2.5V
Input impedance 6.8 kilohms
LANC jack
Stereo minimini jack (ø 2.5 mm)

LASER LINK

Video/audio
IR space transmission system according to EIAJ (Electric Industries Association of Japan) standards
Audio carrier wave
Lch : 4.3MHz
Rch : 4.8MHz

General

Power requirements
7.2 V (battery insertion input)
8.4 V (DC IN jack)
Average power consumption
4.1 W during camera recording using viewfinder
5.2 W during camera recording using LCD screen
3.9 W during playback using LASER LINK (when viewfinder is on and LCD is off)
Operating temperature
0°C to 40°C
Storage temperature
-20°C to 60°C
Dimensions
Approx. 93 x 103 x 193mm (w/h/d)
Mass
Approx. 880 g excluding the battery pack and the cassette
Approx. 950 g including the battery pack NP-F330, lithium battery and cassette DVM60
Approx. 1 kg including the battery pack NP-F550, lithium battery and cassette DVM60

Approx. 1.1 kg including the battery pack NP-F750, lithium battery and cassette DVM60
Approx. 1.2 kg including the battery pack NP-F950, lithium battery and cassette DVM60
Microphone
Electret condenser microphone, Stereo type
Speaker
Dynamic-speaker
Supplied accessories
See page 6.

AC power adaptor

Power requirements
100 to 240 V AC, 50/60 Hz
Power consumption
23 W
Output voltage
DC OUT: 8.4 V, 1.5 A in operating mode
Operating temperature
0°C to 40°C
Storage temperature
-20°C to 60°C
Dimensions (Approx.)
125 x 39 x 62 mm (w/h/d)
Mass (Approx.)
280 g excluding power code

Floppy disk adapter

The number of images you can record on a floppy disk
SFN mode : Approx. 7 to 8
FIN mode : Approx. 14 to 16
STD mode : Approx. 23 to 27
Memory
3.5 inch, 2HD floppy disk (1.44 MB)
MS-DOS format
Operating temperature
5°C to 40°C
Dimensions
floppy disk slot : Approx. 101.5 x 17.2 x 147 mm (w/h/d)
PC card slot : Approx. 54 x 11 x 120 mm (w/h/d)
Mass
Approx. 380 g
Power requirements
Supplied from the camcorder.

Design and specifications are subject to change without notice.

Identifying the parts

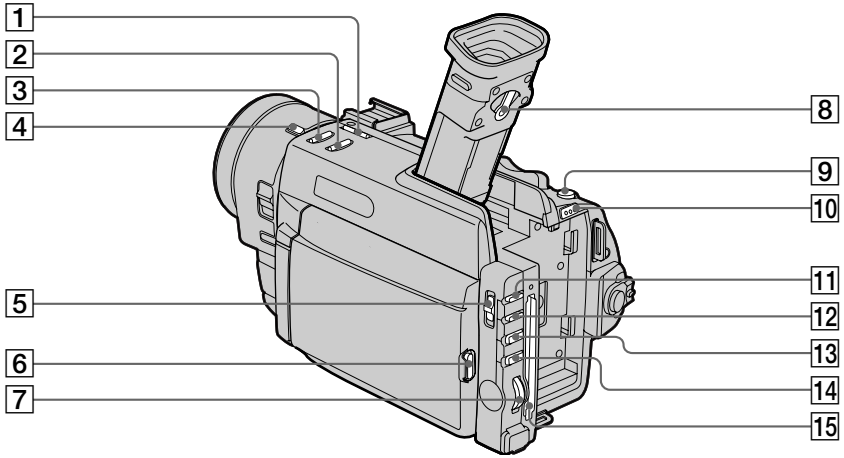

1 EDITSEARCH buttons (p. 21)

2 BACK LIGHT button (p. 38)

3 FADER button (p. 36)

4 ND FILTER button (p. 49)

5 AUTO LOCK selector (p. 44)

6 OPEN switch (p. 22)

7 Control dial (p. 27)

8 Viewfinder lens adjustment lever (p. 13)

9 PHOTO button (p. 33)

10 **B** BATT (battery) RELEASE button (p. 10)

11 SHUTTER SPEED button (p. 45)

12 WHT BAL (white balance) button (p. 46)

13 PROGRAM AE button (p. 55)

14 EXPOSURE button (p. 44)

15 Memory card slot (p. 91)

Identifying the parts

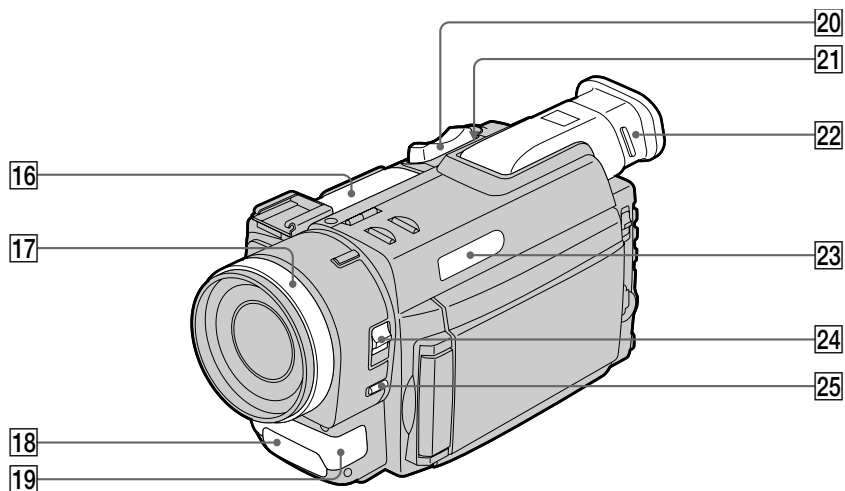

16 Tape transport buttons (p. 22)

- STOP (stop)
- ◀◀ REW (rewind)
- ▷ PLAY (playback)
- ▶▶ FF (fast-forward)
- || PAUSE (pause)
- REC (record)

17 Focus ring (p. 58)

18 LASER LINK transmitter (p. 71) /
Remote sensor (p. 140)

19 Built-in microphone

20 Power zoom lever (p. 14)

21 LASER LINK button (p. 71)

22 Viewfinder (p. 13)

23 Display window (p. 142)

24 FOCUS switch (p. 58)

25 PUSH AUTO button (p. 58)

Identifying the parts

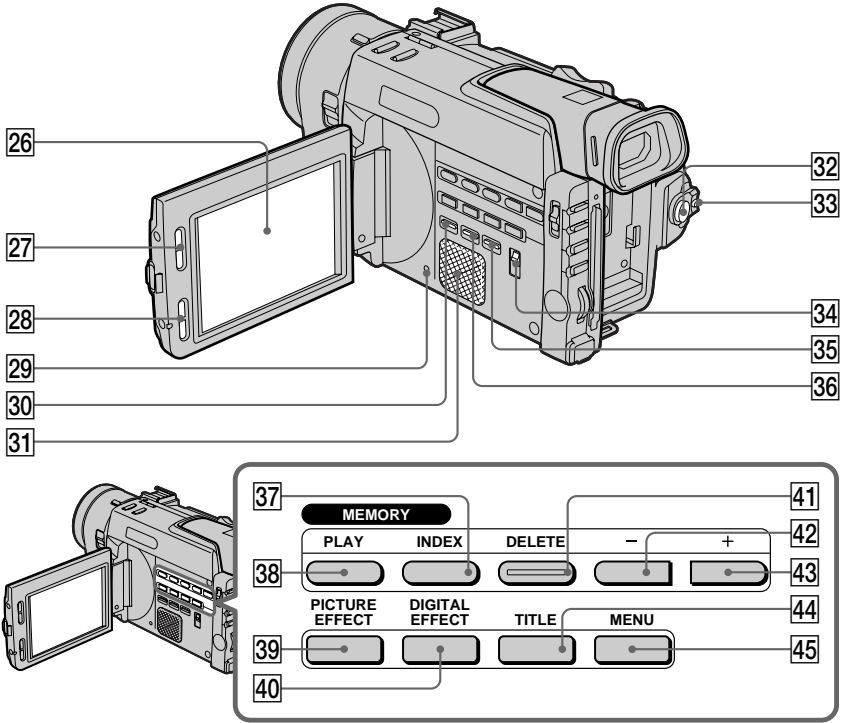

26 LCD Screen (p. 16)

27 LCD BRIGHT buttons (p. 16, 22)

28 VOLUME buttons (p. 22)

29 RESET button (p. 131)

30 DATA CODE button (p. 81)

31 Speaker

32 START/STOP button (p. 12)

33 POWER switch (p. 12, 22)

34 START/STOP MODE selector (p. 15)

35 END SEARCH button (p. 24)

36 DISPLAY button (p. 22)

37 MEMORY INDEX button (p. 106)

38 MEMORY PLAY button (p. 105)

39 PICTURE EFFECT button (p. 41)

40 DIGITAL EFFECT button (p. 42)

41 MEMORY DELETE button (p. 109)

42 MEMORY - button (p. 105, 109)

43 MEMORY + button (p. 105, 109)

44 TITLE button (p. 63, 66)

45 MENU button (p. 27)

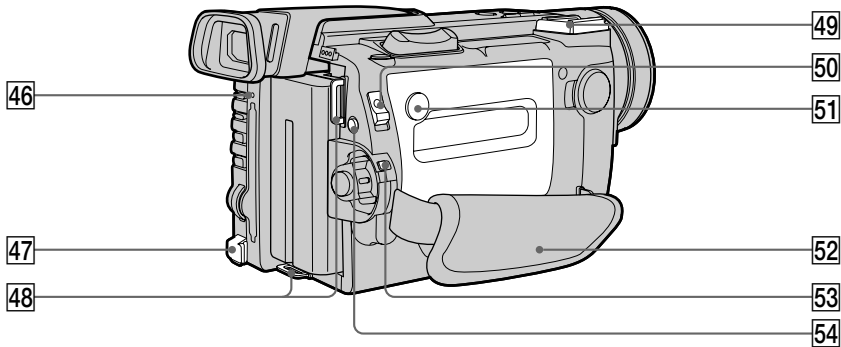

46 Access lamp (p. 93)

47 DC IN jack (p. 8)

48 Hooks for shoulder strap (p. 140)

49 Intelligent accessory shoe

50 EJECT switch (p. 11)

51 PUSH button (p. 11)

52 Grip strap (p. 19)

53 Lock knob (p. 13)

54  (self-timer) button (p. 18)







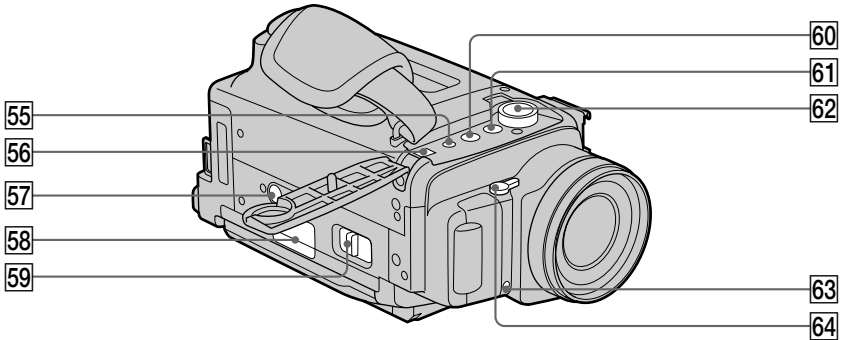

Note on the intelligent accessory shoe

Supplies power to optional accessories such as a video light or microphone. The intelligent accessory shoe is linked to the POWER switch, allowing you to turn on and off the power supplied by the shoe. Refer to the operating instruction of the accessory for further information. To connect an accessory, press down and push it to the end, and then tighten the screw. To remove an accessory, loosen the screw, and then press down and pull out the accessory.

Identifying the parts



- 55** LANC  control jack
 stands for Local Application Control Bus System. The  control jack is used for controlling the tape transport of video equipment and peripherals connected to it. This jack has the same function as the jack indicated as CONTROL L or REMOTE.
- 56**  DV IN/OUT jack (p. 91)
 This “i.LINK” mark is a trademark of Sony Corporation and indicates that this product is in agreement with IEEE 1394-1995 specifications and their revisions.
 The  DV IN/OUT jack is i.LINK compatible.
- 57** Tripod receptacle (p. 20)
 Make sure that the length of the tripod screw is less than 6.5 mm. Otherwise, you cannot attach the tripod securely and the screw may damage the camcorder.
- 58** Stand
- 59** MEMORY RELEASE lever
- 60**  (headphones) jack (p. 22)
- 61** AUDIO/VIDEO jack (p. 70, 82)
- 62** S VIDEO jack (p. 34, 70, 82)
- 63** Camera recording lamp
- 64** MIC jack (PLUG IN POWER) (p. 88)
 Connect an external microphone (not supplied). This jack also accepts a “plug-in-power” microphone.

Floppy disk adapter

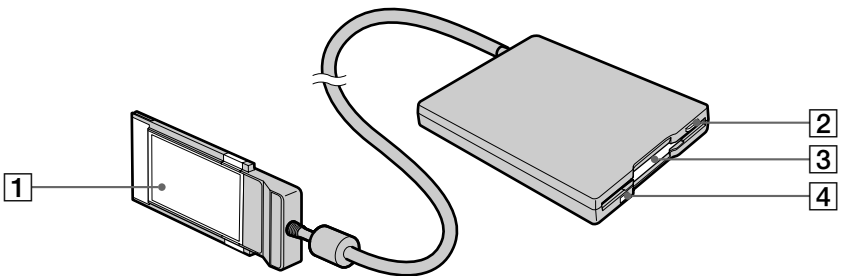

- 1** Memory slot connector (p. 93)
- 2** Floppy disk eject button (p. 94)
- 3** Floppy disk slot (p. 94)
- 4** Access lamp (p. 93)

Remote Commander

The buttons that have the same name on the Remote Commander as on the camcorder function identically.

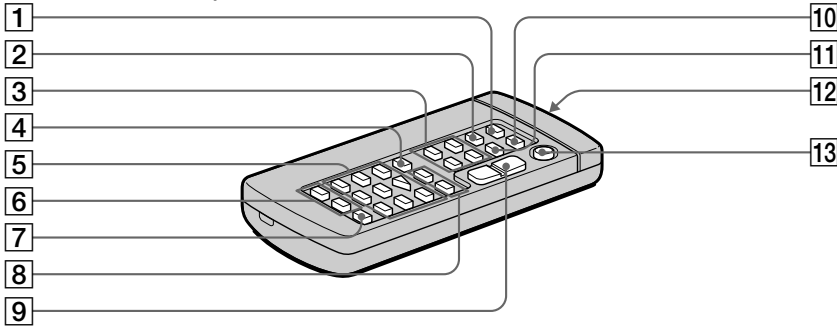

1 PHOTO button (p. 33)

2 DISPLAY button (p. 22)

3 Memory control buttons (p. 105)

4 SEARCH MODE button (p. 74, 76, 77)

5 Tape transport buttons (p. 22)

6 REC button (p. 87)/MARK button (p. 84)

7 AUDIO DUB button (p. 89)

8 ◀◀/▶▶ buttons (p. 74, 76, 77)

9 Power zoom button (p. 14)

10 ZERO SET MEMORY button (p. 80)

11 DATA CODE button (p. 81)

12 Transmitter

Point toward the remote sensor to control the camcorder after turning on the camcorder.

13 START/STOP button (p. 12)

To prepare the Remote Commander

To use the Remote Commander, you must insert two R6 (size AA) batteries. Use the supplied R6 (size AA) batteries.

- (1) Remove the battery cover from the Remote Commander.
- (2) Insert both of the R6 (size AA) batteries with correct polarity.
- (3) Put the battery cover back onto the Remote Commander.

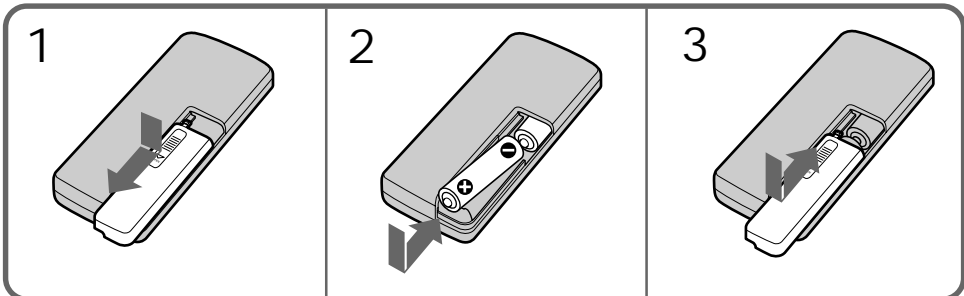

Identifying the parts

Note on battery life

The batteries for the Remote Commander last about 6 months under normal operation. When the batteries become weak or dead, the Remote Commander does not work.

To avoid damage from possible battery leakage
Remove the batteries when you will not use the Remote Commander for a long time.

Remote control direction

Aim the Remote Commander to the remote sensor.

The operative range of the Remote Commander is about 5 m indoors. Depending on the angle, Remote Commander may not activate the camcorder.

Notes on the Remote Commander

- Keep the remote sensor away from strong light sources such as direct sunlight or illumination. Otherwise, the remote control may not be effective.
- Be sure that there is no obstacle between the remote sensor on the camcorder and the Remote Commander.
- This camcorder works in commander mode VTR 2. The commander modes (1, 2 and 3) are used to distinguish this camcorder from other Sony VCRs to avoid remote control misoperation. If you use another Sony VCR in commander mode VTR 2, we recommend you change the commander mode or cover the remote sensor of the VCR with black paper.

Attaching the shoulder strap

Attach the supplied shoulder strap to the hooks for the shoulder strap.

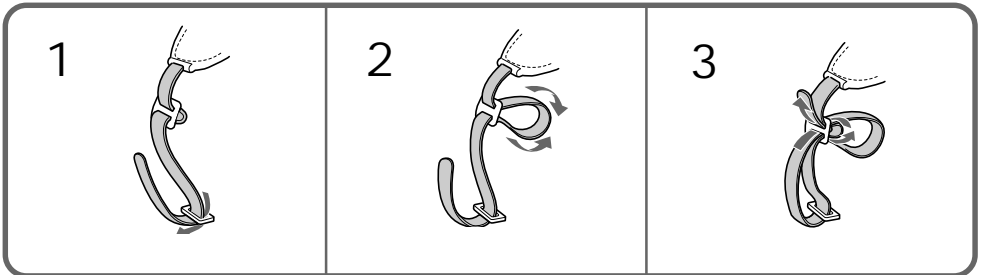

Operation indicators

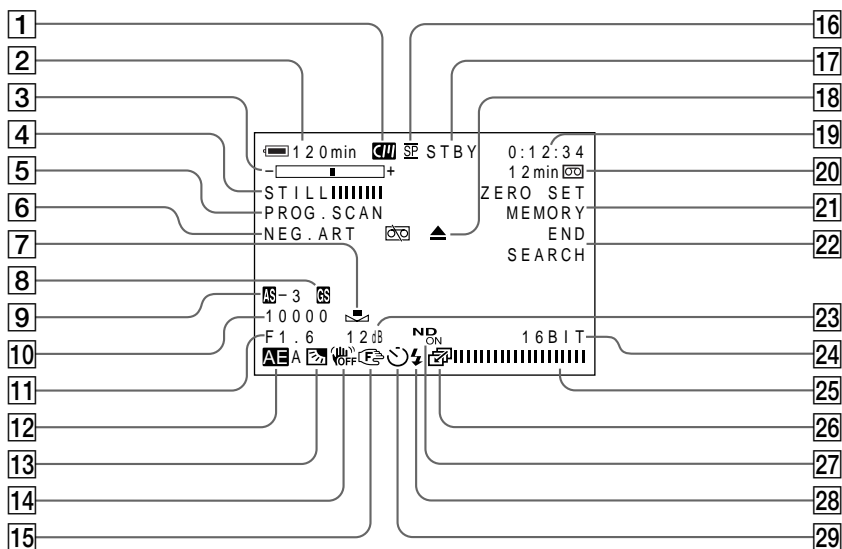

1 Cassette memory indicator (p. 116)

2 Remaining battery indicator (p. 120)



3 Zoom indicator (p. 14) /Exposure indicator (p. 44) /Data file name indicator (p. 92)

4 Digital effect indicator (p. 42)

5 PROG. SCAN indicator (p. 35) / 16:9WIDE indicator (p. 39)

6 Picture effect indicator (p. 40)

7 White balance indicator (p. 46)

8 Gain shift indicator (p. 53)

9 AE shift indicator (p. 52)

10 Shutter speed indicator (p. 45)

11 Aperture indicator (p. 55)

12 Program AE indicator (p. 54)

13 Back light indicator (p. 38)

14 Steady shot OFF indicator (p. 51)

15 Manual focus/Infinity indicator (p. 57)

16 Recording mode indicator (p. 30)

17 Standby/Recording indicator (p. 12) /Tape transport mode indicator (p. 22) /Image quality mode indicator (p. 95)

18 Warning indicators (p. 143)

19 Time code indicator (p. 13) /Self diagnosis indicator (p. 132) /Image number indicator (p. 106)

20 Remaining tape indicator (p. 142) /Memory playback indicator (p. 106)

21 ZERO SET MEMORY indicator (p. 80)

22 END SEARCH indicator (p. 24)

23 Gain indicator (p. 81)

24 Audio mode indicator (p. 30)

25 Microphone level indicator (p. 48)

26 Continuous mode indicator (p. 104)

27 ND filter indicator (p. 49)

28 Video flash ready indicator (p. 33)

29 Self-timer indicator (p. 18)

Display window

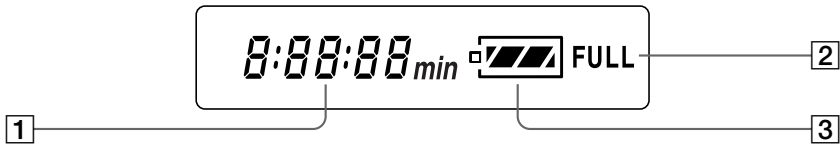

- 1** Remaining time in minutes indicator (p. 8) /
Tape counter (p. 80) /
Memory counter (p. 106) /
Time code indicator (p. 12)
- 2** FULL charge indicator (p. 8)
- 3** Remaining battery indicator (p. 8, 120)

To watch the demonstration

You can watch a brief demonstration of pictures with special effects. If the demonstration appears when you turn on the camcorder for the first time, exit the demo mode to use your camcorder.

To enter demo mode

- (1) Eject the cassette and set the POWER switch to VTR.
- (2) While holding down \triangleright , set the POWER switch to CAMERA. The demonstration starts.
The demonstration stops when you insert the cassette.

Note that once you enter demo mode, this mode is retained as long as the vanadium rechargeable battery is in place. Therefore, demonstration starts automatically 10 minutes later every time you set the POWER switch to CAMERA, and after you eject the cassette.

To exit demo mode

- (1) Set the POWER switch to VTR.
- (2) While holding down \square , set the POWER switch to CAMERA.

Warning indicators



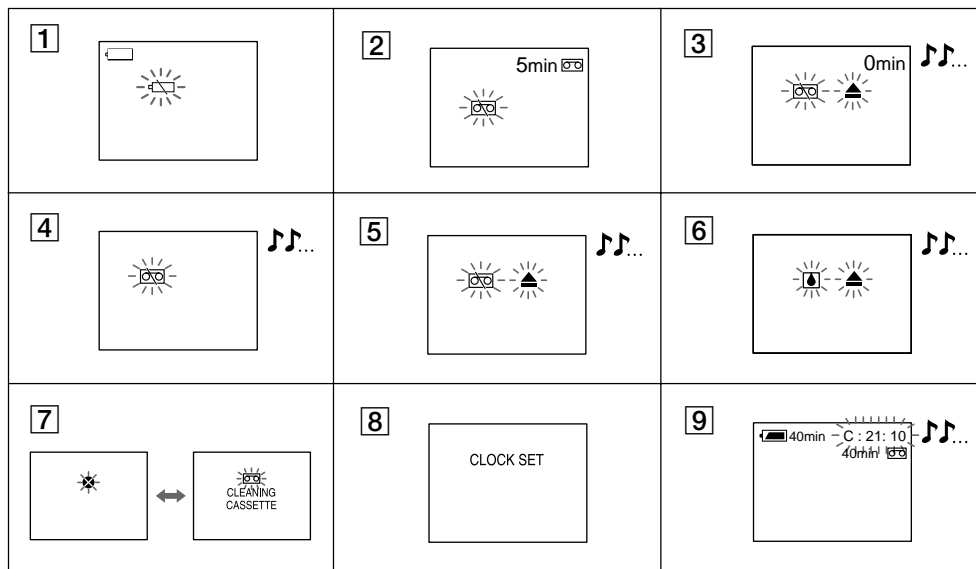

If indicators flash on the LCD screen or in the viewfinder or warning messages appear on the screen, check the following:

♪: You can hear the beep sound when BEEP is set to MELODY or NORMAL in the menu system.



- 1** The battery is weak or dead.
Slow flashing: The battery is weak.
Fast flashing: The battery is dead.
Depending on conditions, the ♻️ indicator may flash, even if there are 5 to 10 minutes remaining.
- 2** The tape is near the end.
The flashing is slow.
- 3** The tape has run out.
The flashing becomes rapid.
- 4** No tape has been inserted.
- 5** The tab on the tape is out (red).
- 6** Moisture condensation has occurred.
(p. 123)
- 7** The video heads may be contaminated.
(p. 123)
- 8** The clock is not set.
When this message appears though you set the date and time, the vanadium-lithium battery is discharged. Charge the vanadium-lithium battery. (p. 117)
- 9** Some other trouble has occurred.
Use the self-diagnosis function (p. 132). If the display does not disappear, contact your Sony dealer or local authorized Sony service facility.

Continued to the next page

<p>10</p> <div style="border: 1px solid black; padding: 10px; text-align: center;"> <p>FOR "InfoLITHIUM" BATTERY ONLY</p> </div>	<p>11</p> <div style="border: 1px solid black; padding: 10px; text-align: center;">  </div>	<p>12</p> <div style="border: 1px solid black; padding: 10px; text-align: center;"> <p>MVC0001</p> </div> <p style="text-align: right;">♪♪...</p>
<p>13</p> <div style="border: 1px solid black; padding: 10px; text-align: center;">  </div> <p style="text-align: right;">♪♪...</p>	<p>14</p> <div style="border: 1px solid black; padding: 10px; text-align: center;">  </div> <p style="text-align: right;">♪♪...</p>	<p>15</p> <div style="border: 1px solid black; padding: 10px; text-align: center;">   </div> <p style="text-align: right;">♪♪...</p>

10 The battery is not the "InfoLITHIUM" type.

11 The tape has no cassette memory. (p. 4)

12 The file cannot be read properly.

13 The image data file is protected.
The flashing is slow.

14 The tape has no memory left or cannot use the memory.

15 The protect tab is set to prevent accidental erasure.

-
- A, B**
- Audio mode 30
 - AUTO SHTR 28
 - Battery release 10
 - BEEP 31
-
- C**
- Car battery 26
 - Cassette memory 4
 - Charging battery pack 8
 - Charging vanadium-lithium battery 117
 - Cleaning video heads 123
 - Clock set 118
 - Color TV system 4, 126
 - Connection 70, 82
 - Continuous 103
 - COPY INHIBIT 116
-
- D, E**
- Data Code 81
 - Date search 74
 - Demo 142
 - DISPLAY 22
 - Digital zoom 15
 - DV connecting cable 83
 - DV format 116
 - DV IN/OUT 83
 - Editing 82
 - EJECT 11, 93, 94
 - END SEARCH 21, 24
 - Exposure 44
-
- F, G, H**
- Fade-in/fade-out 36
 - FADER 36
 - Floppy disk 91
 - Floppy disk adapter 91
 - Format 96
 - FOCUS 57
 - Full charge 8
-
- I, J, K, L**
- i.LINK 138
 - Image quality mode 95
 - INDEX (Multiple) display 106
 - InfoLITHIUM 121
 - LASER LINK 71
 - Lens hood 14
 - LCD BRIGHT 16, 22
 - LP mode 13
-
- M, N**
- Manual adjustment 44
 - Manual focus 57
 - Memory card 91
 - Memory card slot 91
 - Memory Stick 91
 - Menu system 27
 - Microphone level 48
 - Mirror mode 17
 - Moisture condensation 123
 - Normal charge 8
-
- O, P, Q**
- PHOTO 33
 - Photo scan 77
 - Photo search 79
 - Playback on a TV 70
 - Playback pause 23
 - Power sources 25
 - Power zoom 14
 - PROGRAM AE 54
 - Progressive 35
 - PROG. SCAN 35
-
- R**
- Remaining battery indicator .. 120
 - Remaining tape indicator 142
 - Remote Commander 139
-
- S**
- Self-diagnosis function 132
 - Self-timer recording 18
 - Slide show 114
 - SP mode 13
 - Standby mode 12
 - START/STOP MODE selector 15
 - SteadyShot 51
 - Still image 98
-
- T, U, V**
- Time code 13
 - Title (making) 66
 - Title (superimposition) 63
 - Title search 76
 - Tripod mounting 20
 - VOLUME 22
-
- W, X, Y, Z**
- Wide TV mode 39
 - Zebra pattern 50
 - ZERO SET MEMORY 80
 - Zoom 14

