

HC10DT

Human-Collaborative Robot

Key Benefits

Enables humans to safely work with robots

Through-arm utilities eliminate external cables and associated risks, and simplify end-of-arm tooling installation

Cast aluminum construction for industrial durability

Designed to avoid pinch points, increasing worker safety

Easy teaching for quick implementation

Specifications

10 kg payload

1,200 mm maximum reach

±0.1 mm repeatability

Applications

Assembly

Machine Tending

Material Handling

Packaging



- 6-axis collaborative robot designed for a wide variety of applications.
- Power and force limiting technology is used to protect the worker from potentially harmful contact situations.
- Depending on risk assessment, the HC10DT can operate without additional protective measures such as a safety fence, resulting in reduced cost and space requirements.
- Simple and easy to program, enabling the operator to quickly perform changeovers.
- Meets established safety standards including:
 - ISO 13849-1: Safety functions industrial robot controller, Category 3 PLd (TUV-certified)
- The HC10DT allows hand-guided programming without the need for a pendant to program points. It features a convenient toggle button to actuate an end-of-arm tool and to insert tool I/O into the job without requiring a pendant.
- Smart Pendant features an innovative interface that simplifies robot programming. Its built-in Smart Frame technology eliminates the use of conventional coordinate (X, Y, Z) frames for easy command of robot movement.
- Controlled by Yaskawa's ultra-compact, yet powerful, YRC1000micro controller. A 120 VAC, single-phase option is available.

The CASE for Collaboration

CAPABLE – *improves production rate*

- Industrial-grade payload and speed for real world applications
- Can be used in a wide variety of handling and assembly applications
- Easily integrated into factory automation systems using discrete I/O or fieldbus networks such as Ethernet/IP

AFFORDABLE – *quickly achieves ROI*

- Reduced physical guarding
- Simplified, built-in networked safety I/O
- Built on Yaskawa legacy of quality and reliability

SAFE – *reduces risk*

- Advanced pinchless geometry
- Innovative thru-arm utilities
- Power and force limiting with FSU (Functional Safety Unit)

EASY – *empowers employees*

- Teach by hand guiding
- Quick fault recovery
- Simplifies basic training needs

HC10DT Robot

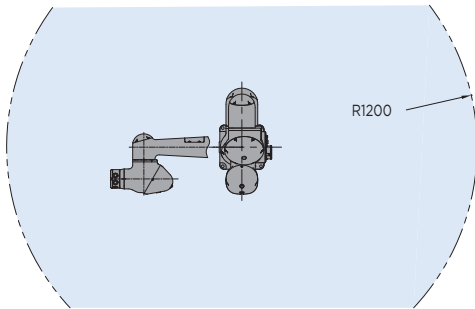
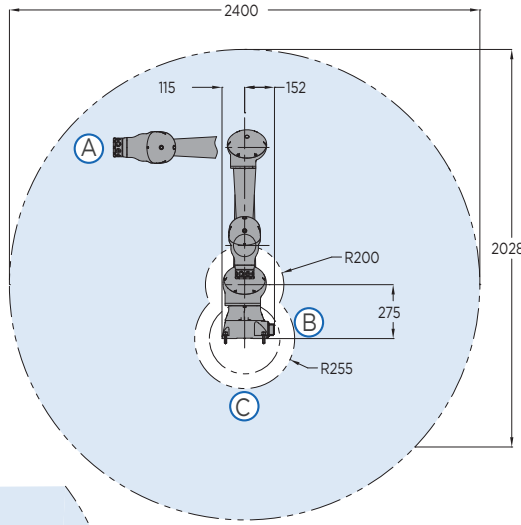
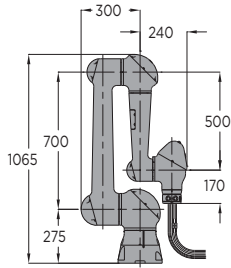

VIEW A

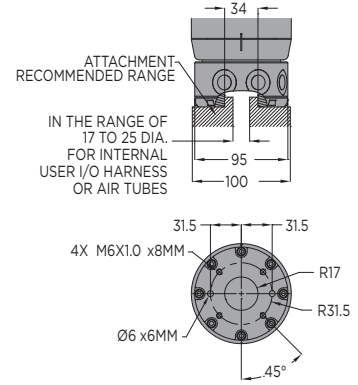

VIEW B

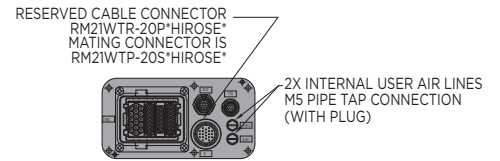

VIEW C

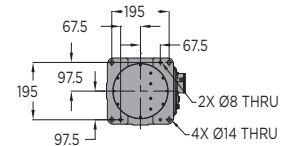

All dimensions are metric (mm) and for reference only. Request detailed drawings for all design/engineering requirements.

SPECIFICATIONS

Axes	Maximum motion range [°]	Maximum speed [°/sec.]	Allowable moment [N•m]	Allowable moment of inertia [kg•m ²]
S	±180	130	-	-
L	±180	130	-	-
U	+355/-5	180	-	-
R	±180	180	27.4	0.78
B	±180	250	27.4	0.78
T	±180	250	9.8	0.1

Mounting Options: Floor, Wall, Ceiling, Tilt

Options

- Third-party function-specific collaborative tooling and accessories

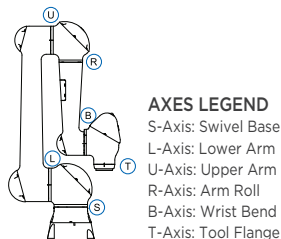

Item	HC10DT
Controlled axes	6
Maximum payload [kg]	10
Repeatability [mm]	±0.1
Maximum reach [mm]	1,200
I/O Expansion	Ethernet/IP, DeviceNet, Profibus - DP, Remote I/O, Discrete I/O, Analog I/O and other networks available
Tool Center Point (TCP)	Non-collaborative mode: 1000 mm/s Collaborative mode: 250 mm/s* (factory default)
Internal user I/O cable	8 X 0.2 mm ² and 8 X 0.3 mm ² wires
Internal user air lines	2 x 4 mm OD
Power requirements	Single-phase 200/230 VAC (+10% to -15%), 50/60 Hz ±2% 120 VAC available with optional transformer Three-phase 200/220 VAC (+10% to -15%), 50/60 Hz ±2%
Power rating [kVA]	1
Weight [kg]	48
IP classification	IP20
Safety certification	TUV Rheinland
Designed to meet	Functional Safety, Cat. 3 PLd, Safety Functions, EN ISO 13849:2008 PLd

* Collaborative mode speed is user-defined based on safety assessment

Yaskawa America, Inc. | Motoman Robotics Division

100 Automation Way
 Miamisburg, OH 45342
 Tel: 937.847.6200 | motoman.com

Motoman is a registered trademark. All other marks are the trademarks and registered trademarks of Yaskawa America, Inc. Technical specifications subject to change without notice. DS-778-B ©2019 Yaskawa America, Inc. MAY 2019

YASKAWA