



OT Security. At Scale.

Securing Your
Industrial Digital
Transformation
Journey



SCADAfence

Smart Operational Networks Come at a Security Price



Modern operational technology (OT) networks are constantly evolving due to developments such as Industrial Internet of Things (IIoT), Industry 4.0, smart grid and more. To stay competitive, companies are adopting these beneficial technologies to optimize their operations and significantly cut operational costs.

These new technologies increase the connectivity and the complexity of operational environments, and as a result, their exposure to potential cyber-attacks or human error. In the past, operators trusted network segmentation, isolation or air-gapping as an effective security measure. But due to the increasing connectivity between the OT, IT and other networks, this is no longer true, and therefore the use of OT network tailored security tools are critical for the protection, visibility and control of operational environments.

The Need for a Dedicated OT Network Security Solution

Applying IT-oriented security tools in OT networks does not protect the OT networks from OT-specific attack vectors. Utilizing IT security tools in OT might even be as dangerous as “no security”, as they provide a false sense of security. OT networks, equipment and protocols are different from their IT counterparts and therefore, require a different mindset. Planning a robust OT network security architecture requires security solutions that are tailored for their characteristics, and are specifically designed for the high availability nature and the unique traffic patterns of the OT network.

SCADAfence Platform

Real-time Continuous Network Monitoring and Protection for OT Networks

SCADAfence Platform is an industrial network monitoring system that provides cybersecurity and visibility for ICS/SCADA networks. SCADAfence Platform provides automatic asset discovery and inventory management, threat detection and risk management. By employing a wide range of algorithms, machine learning and AI, it detects anomalies and security events that can compromise availability and affect the safety and reliability of the OT network and its assets. SCADAfence Platform is the only solution in the market that is able to support the unique requirements of large scale industrial networks from a size, complexity and coverage perspective, while maintaining an affordable TCO.

SCADAfence Platform
is a software-based
non-intrusive
solution, designed to
reduce the risks of:

- Operational downtime and production process manipulation
- Malware and ransomware infection
- External or internal cyber attacks
- Human error, misconfigurations and device malfunction

SCADAfence Platform Offers Superior Protection of OT Networks with Powerful Features that Include:

- Automatic discovery and full visibility and management of OT asset inventory
- Network dashboards for traffic and security health
- Network mapping and connectivity analysis
- Detection of suspicious activities, exposures and malware attacks
- Operational alerts on asset and service availability, and performance issues
- Proactive actionable warnings regarding risks and vulnerabilities in the OT network
- Deep analysis of industrial protocols and industrial equipment activities
- Automated management level reports

SCADAfence Platform seamlessly integrates in existing networks. It completes the firewall and SIEM solutions, by providing monitoring and alerting capabilities. Our platform connects to switches' mirroring ports, and integrates with existing security products and incident handling tools via standard industry interfaces.

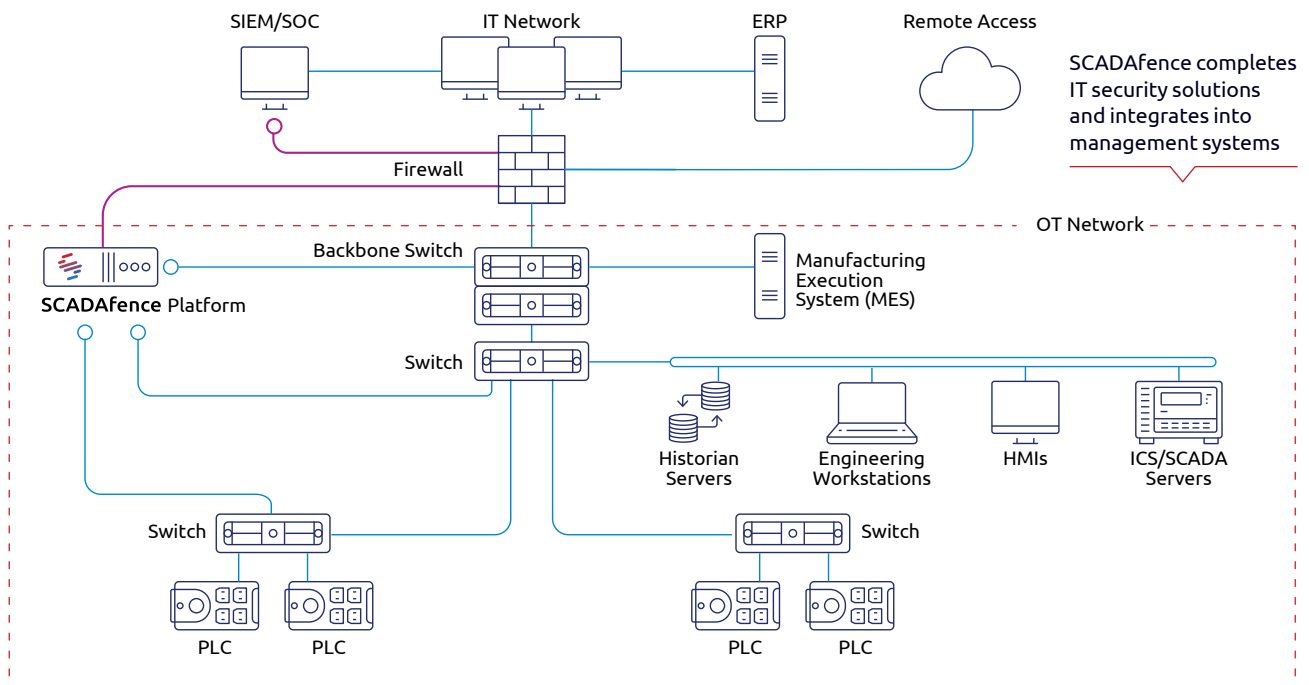

Why SCADAfence?



Industry leading performance

The only solution to provide full coverage of network traffic monitoring (no sampling, no filtering)



Industry leading scalability

Designed to protect the smallest to the most complex, large-scale manufacturing networks



Seamless deployment

Automatic learning and tuning



Cost effective

Efficient deployment with high-performing sensors and low TCO



No interference with production continuity

Non-intrusive solution, can be added to existing running networks

About SCADAfence

SCADAfence helps companies with large-scale operational technology (OT) networks embrace the benefits of industrial IoT by reducing cyber risks and mitigating operational threats. Our non-intrusive platform provides full coverage of large-scale networks, offering best-in-class detection accuracy, asset discovery and user experience. SCADAfence seamlessly integrates OT security within existing security operations, bridging the IT/OT convergence gap. We deliver security and visibility for some of the world's most complex OT networks, including Europe's largest manufacturing facility. Thanks to SCADAfence, companies in manufacturing, building management and critical infrastructure industries can operate securely, reliably and efficiently as they go through the digital transformation journey. SCADAfence was named by Forbes as one of the [Top 25 IoT Startups to Watch In 2019](#).

Partners



Industries



Manufacturing



Critical Infrastructure



Building Management Systems

“OT networks connectivity has become a mandatory business requirement, triggering a shift in the security mindset from “How can I isolate?” to “How can I stay secure while connected?”

Our offices

Offices: New York, Munich, Tokyo, Tel Aviv

Contact us: info@scadafence.com

www.scadafence.com



SCADAfence