

Wonderware IntelaTrac

Wonderware IntelaTrac enables manufacturers and processors to achieve reliable, safe and profitable operations through consistent execution of best practices by the field workforce – accelerating and sustaining mainstream process improvements.



Wonderware IntelTrac Features



KEY BENEFITS

- Key success factor for field operational excellence
- Helps steward the consistent execution of best practices
- Provides strategy for monitoring stranded assets
- Supports rapid response to changing business conditions
- Key success factor for equipment reliability
- Helps assimilate new field workers
- Underlies compliance, health and safety program requirements

The Industry-leading Mobile Workforce and Decision Support System

Wonderware® IntelTrac® accelerates and sustains operational process improvements and is a key component of an effective Operations Management System. IntelTrac helps insure that best operating and regulatory procedures are followed at all times, data is collected on non-instrumented plant assets, critical environmental, health and safety inspections are performed on schedule and mobile operators have the information at their fingertips to operate plant assets in the most effective manner possible.

Helping Your Front Line Manage Your Bottom Line

Operational Excellence starts with operators. IntelTrac brings the field operator into the automation loop by utilizing a combination of workforce management software, mobile handheld computers, monitoring devices and Radio Frequency Identification (RFID) equipment tags or bar codes. This mobile framework results in a significantly improved decision support system for managing plant assets.

Workers are easily guided through a question and answer process which helps uncover hidden bottlenecks and process or equipment problems. If problems are found, IntelTrac can immediately guide workers through additional steps or actions to properly identify and address the developing issue.

IntelTrac exception-based, web reports keep everyone on the team up-to-speed on the current state of plant operations.

IntelTrac Software Development Kit (SDK) ensures the lowest total cost of ownership by adding a highly extensible mobile framework.

Enforce Best Operating Procedures

Best practices are only meaningful if they are consistently and broadly applied across an enterprise. IntelTrac rounds are presented to mobile workers and each step can be tracked to ensure compliance and accountability.

Strategy for Stranded Assets

Stranded or non-instrumented assets often represent 40 to 60% of your asset base but are too often “invisible” to management. IntelTrac provides a cost effective strategy for monitoring and reporting back on the performance of stranded assets.

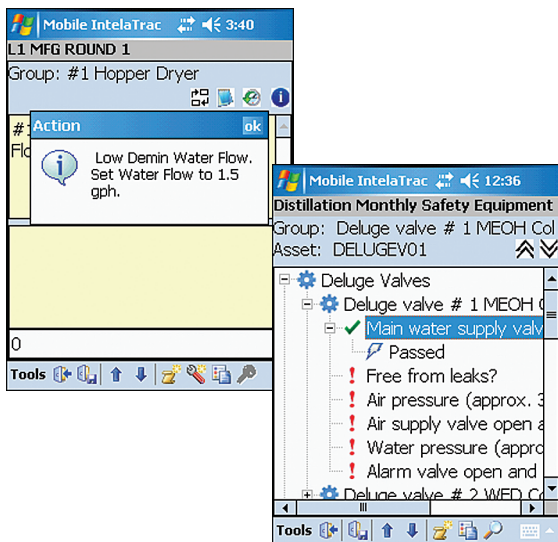

Wonderware
IntelTrac

Wonderware IntelTrac

Features (continued)

Respond Faster And Improve Your Competitiveness

For the first time, you can execute pre-defined strategies when your business or environmental conditions change, allowing you to improve your organizational agility and competitiveness. IntelTrac Dynamic Procedures allow pre-configured procedures to be automatically passed to your field operators so they can begin securing a facility or ramping up production on a moment's notice. Teams know exactly what to do and when. Lag time and confusion are minimized.

As conditions change, the IntelTrac highly extensible and open mobile framework can also deliver mobile procedures directly from a wide range of plant systems. The mobile worker then executes these specific tasks and forwards any collected data information back to the host system. Legacy plant systems never designed with a mobile capability, such as historians, LIMS systems, MES systems and CMMS/EAM systems can now incorporate mobile task execution and field data collection.

Achieve Greater Process Reliability and Asset Effectiveness

IntelTrac empowers field workers to be part of the reliability solution; it helps drive collective behavior and a culture of asset ownership between operations and maintenance. Equipment condition data such as vibration or temperature can be easily collected by field operators using the IntelTrac mobile solution as they do their regular operating rounds. Stranded or non-instrumented plant assets can now be efficiently monitored.

The IntelTrac asset-centric approach allows data collected by any operator or plant worker to be aggregated together for a common asset history. This means a more complete and comprehensive view of asset performance and health.

Better Management of Workforce Turnover

The IntelTrac innovative on-the-job training approach gets your newest field workers up to speed—FAST. IntelTrac allows experienced workers to incorporate their knowledge into operating and inspection rounds. This means best practices can be easily documented and used by all field workers, even the most junior of operators—insulating plants or facilities from a sudden loss of operating knowledge.

Unifying Your Field Workforce with Your Plant Automation System

Now the state-of-the-art Wonderware System Platform can share data with your IntelTrac equipped mobile workforce. The myriad of plant automation data can now be funneled to your mobile workers keeping them up-to-date on current operational conditions. You can also use the Mobile IntelTrac system to push field collected data back up into the automation system so it can be exposed in operator displays or to engineers or managers utilizing plant information portals.



Wonderware IntelTrac

Features (continued)

Improving the Efficiency of Your Maintenance Organization

IntelTrac is a natural tool for improving the efficiency of maintenance activities. Mobile IntelTrac can be loaded with a complete list of daily maintenance tasks (including step-by-step instructions) so critical maintenance can be done right the first time.

If a wireless network is present, information on work order status, work requests, and current operating conditions can be made available to your field workers in real time. Maintenance workers will have the detailed information at their fingertips so they can get the job done in the shortest possible time.

Better Field Management of Capital Projects

Even with the best team, managing the installation and commissioning of new capital projects and turnarounds can be challenging. How do you know when specific field tasks have been accomplished? | And if things change, and they always do, how do you ensure that everyone is on the same page?

IntelTrac can provide the vital mobile infrastructure, including RFID location verification technology, that you can exploit to keep everyone informed and working the task list.

System Overview

IntelTrac is an enterprise level software and hardware solution that delivers a mobile workforce management solution to a wide range of industries. Languages supported include: English, French, Spanish, German, Dutch, Swedish, Russian, Japanese and Chinese (Traditional and Simplified).

Server Components/Integration Software

IntelTrac Database Server: Microsoft® SQL database server where system configuration, procedure content and collected data resides.

IntelTrac Synchronization Server: Microsoft Server for mobile device communication and Integrations. Mobile computers connect through the network, either by cradle, WiFi or Cellular to this server. Integrations to external systems are also typically hosted on this server. Integration modules include Wonderware Galaxy, Wonderware Historian, OSIsoft® PI System, AspenTech® IP21, Honeywell® PHD and EAM integrations to Avantis®, SAP-PM and IBM Maximo® along with the IntelTrac Extensibility API components required for custom integrations.

IntelTrac Web Reports Server: Microsoft Server configured with IIS (Internet Information Services) hosting the IntelTrac Web Reports application.

Wonderware IntelTrac

Features (continued)

Desktop IntelTrac Clients

IntelTrac Management Center (IMC): Hosts the individual IntelTrac application components used for content creation and management (Procedure Builder), scheduling (Schedule Manager), review & approval (Auditor Plus) as well as the Administration & Security application components. The Web Reports application is also accessed from the IMC.

Workstation IntelTrac: Desktop procedure execution interface similar to Mobile IntelTrac.

IntelTrac System Architecture

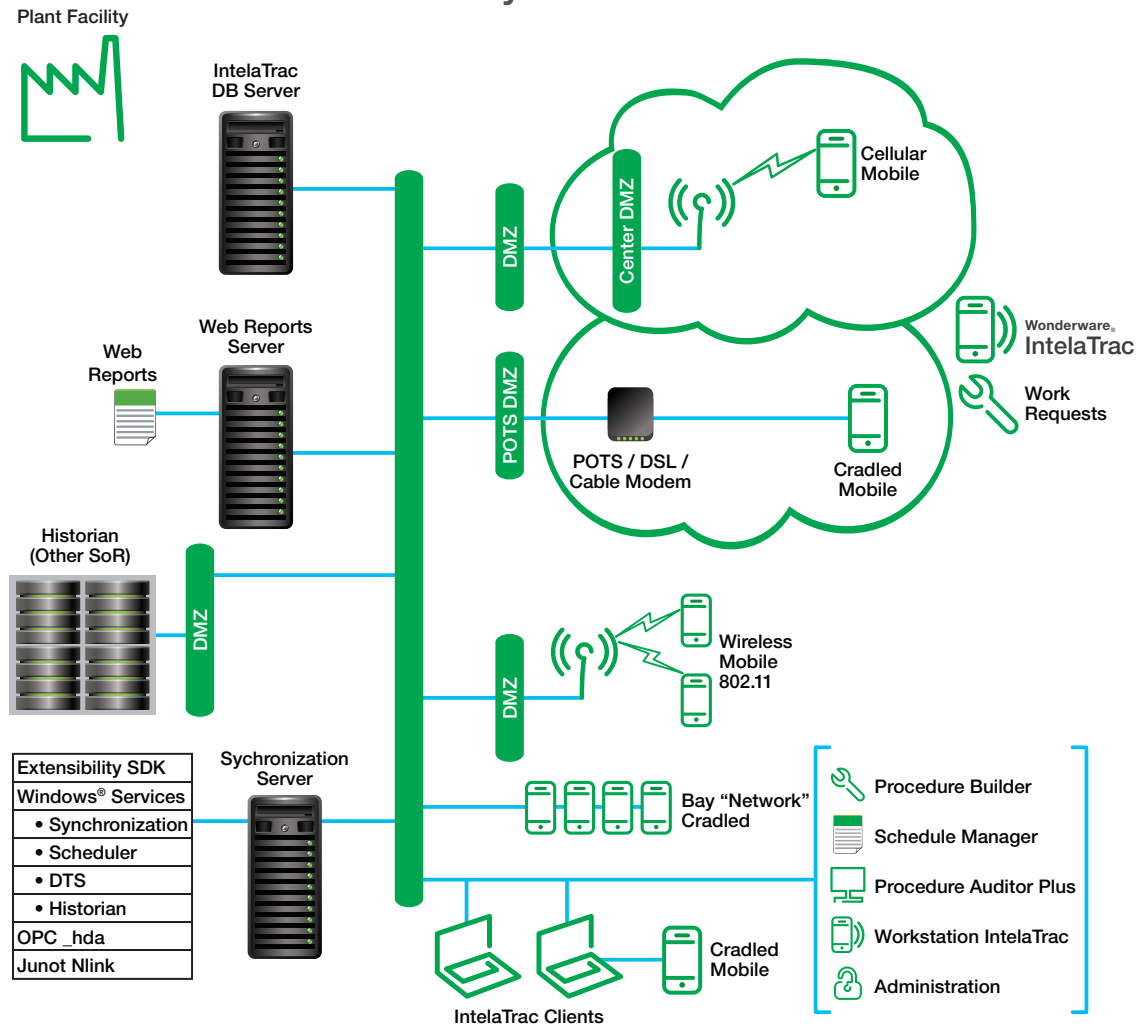

Wonderware Intelatrac

Features (continued)

Mobile Intelatrac Client

Mobile Intelatrac: Windows Mobile client that provides a “best in class” browser style user interface for procedures and data collection tasks on specialized mobile devices.

Mobile Intelatrac for Windows 8.1: Windows PRO 8.1 client that features a modernized user interface for procedures and data collection tasks as well as visual feedback via context sensitive displays on tablet devices.

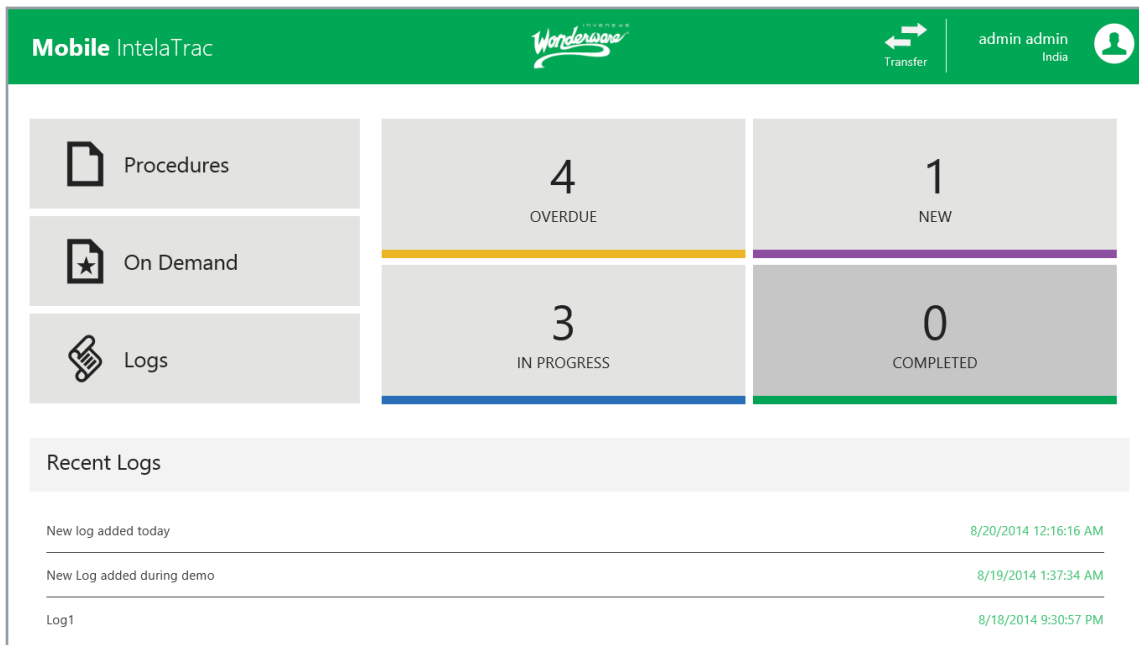

Mobile Intelatrac for Windows 8.1 dashboard

Mobile Devices and Peripherals

Mobile Intelatrac: Supports a broad selection of Windows Mobile based handheld computers from Motorola/Symbol, Intermec, Bartec, and others. Supported peripherals include: RFID and barcode readers, vibration probes, temperature guns, and wireless communication devices.

Mobile Intelatrac for Windows 8.1: Supports commercially available Windows 8.1 PRO tablets such as the Windows Surface Pro, as well as specialized rugged devices from Bartec, ECOM, and others.

For more information on Wonderware Intelatrac, please contact your local Wonderware distributor, or visit: <http://software.invensys.com/products/wonderware/manufacturing-operations-management/intelatrac>

