

Liviu I. Nicolaescu

An Invitation to Morse Theory

– Monograph –

February 27, 2007

Springer

Berlin Heidelberg New York

Hong Kong London

Milan Paris Tokyo

To my mother, with deepest gratitude

Preface

As the title suggests, the goal of this book is to give the reader a taste of the “unreasonable effectiveness” of Morse theory. The main idea behind this technique can be easily visualized.

Suppose M is a smooth, compact manifold, which for simplicity we assume is embedded in a Euclidean space E . We would like to understand basic topological invariants of M such as its homology, and we attempt a “slicing” technique.

We fix a unit vector \mathbf{u} in E and we start slicing M with the family of hyperplanes perpendicular to \mathbf{u} . Such a hyperplane will in general intersect M along a submanifold (slice). The manifold can be recovered by continuously stacking the slices on top of each other in the same order as they were cut out of M .

Think of the collection of slices as a deck of cards of various shapes. If we let these slices continuously pile up in the order they were produced, we notice an increasing stack of slices. As this stack grows, we observe that there are moments of time when its shape suffers a qualitative change. Morse theory is about extracting quantifiable information by studying the evolution of the shape of this growing stack of slices.

From a mathematical point of view we have a smooth function

$$h : M \rightarrow \mathbb{R}, \quad h(x) = \langle \mathbf{u}, x \rangle.$$

The above slices are the level sets of h ,

$$\{x \in M; h(x) = \text{const}\},$$

and the growing stack is the time dependent sublevel set

$$\{x \in M; h(x) \leq t\}, \quad t \in \mathbb{R}.$$

The moments of time when the pile changes its shape are called the *critical values* of h and correspond to moments of time t when the corresponding

hyperplane $\{\langle \mathbf{u}, x \rangle = t\}$ intersects M tangentially. Morse theory explains how to describe the shape change in terms of *local* invariants of h .

A related slicing technique was employed in the study of the topology of algebraic manifolds called the *Picard–Lefschetz theory*. This theory is back in fashion due mainly to Donaldson’s pioneering work on symplectic Lefschetz pencils.

The present book is divided into three conceptually distinct parts. In the first part we lay the foundations of Morse theory (over the reals). The second part consists of applications of Morse theory over the reals, while the last part describes the basics and some applications of complex Morse theory, a.k.a. Picard–Lefschetz theory. Here is a more detailed presentation of the contents.

In chapter 1 we introduce the basic notions of the theory and we describe the main properties of Morse functions: their rigid local structure (Morse lemma) and their abundance (Morse functions are generic). To aid the reader we have sprinkled the presentation with many examples and figures. One recurring simple example we use as a testing ground is that of a natural Morse function arising in the design of robot arms.

Chapter 2 is the technical core of the book. Here we prove the fundamental facts of Morse theory: crossing a critical level corresponds to attaching a handle and Morse inequalities. Inescapably, our approach was greatly influenced by classical sources on this subject, more precisely Milnor’s beautiful books on Morse theory and h -cobordism [M3, M4].

The operation of handle addition is much more subtle than it first appears, and since it is *the* fundamental device for manifold (re)construction, we devoted an entire section to this operation and its relationship to cobordism and surgery. In particular, we discuss in some detail the topological effects of the operation of surgery on knots in S^3 and illustrate this in the case of the trefoil knot.

In chapter 2 we also discuss in some detail dynamical aspects of Morse theory. More precisely, we present the techniques of S. Smale about modifying a Morse function so that it is self-indexing and its stable/unstable manifolds intersect transversally. This allows us to give a very simple description of an isomorphism between the singular homology of a compact smooth manifold and the (finite dimensional) Morse–Floer homology determined by a Morse function, that is, the homology of a complex whose chains are formal linear combinations of critical points and whose boundary is described by the connecting trajectories of the gradient flow. We have also included a brief section on Morse–Bott theory, since it comes in handy in many concrete situations.

We conclude this chapter with a section of a slightly different flavor. Whereas Morse theory tries to extract topological information from information about critical points of a function, min-max theory tries to achieve the opposite goal, namely to transform topological knowledge into information about the critical points of a function. While on this topic, we did not want to avoid discussing the Lusternik–Schnirelmann category of a space.

Chapter 3 is devoted entirely to applications of Morse theory, and in writing it we were guided by the principle, few but juicy. We present relatively few examples, but we use them as pretexts for wandering in many parts of mathematics that are still active areas of research. More precisely, we start by presenting two classical applications to the cohomology of Grassmannians and the topology of Stein manifolds.

We use the Grassmannians as a pretext to discuss at length the Morse theory of moment maps of Hamiltonian torus actions. We prove that these moment maps are Morse–Bott functions. We then proceed to give a complete presentation of the equivariant localization theorem of Atiyah, Borel, and Bott (for S^1 -actions only), and we use this theorem to prove a result of P. Conner [Co]: the sum of the Betti numbers of a compact, oriented smooth manifold is greater than the sum of the Betti numbers of the fixed point set of any smooth S^1 -action. Conner’s theorem implies among other things that the moment maps of Hamiltonian torus actions are *perfect* Morse–Bott function. The (complex) Grassmannians are coadjoint orbits of unitary groups, and as such they are equipped with many Hamiltonian torus actions leading to many choices of perfect Morse functions on Grassmannians.

We used the application to the topology of Stein manifolds as a pretext for the last chapter of the book on Picard–Lefschetz theory. The technique is similar. Given a complex submanifold M of a complex projective space, we start slicing it using a (complex) 1-dimensional family of projective hyperplanes. Most slices are smooth hypersurfaces of M , but a few of them are have mild singularities (nodes). Such a slicing can be encoded by a holomorphic Morse map $M \rightarrow \mathbb{C}P^1$.

There is one significant difference between the real and the complex situations. In the real case, the set of regular values is *disconnected*, while in the complex case this set is *connected*, since it is a punctured sphere. In the complex case we study not what happens as we cross a critical value, but what happens when we go once around it. This is the content of the Picard–Lefschetz theorem.

We give complete proofs of the local and global Picard–Lefschetz formulæ and we describe basic applications of these results to the topology of algebraic manifolds.

We conclude the book with a chapter containing a few exercises and solutions to (some of) them. Many of them are quite challenging and contain additional interesting information we did not include in the main body, since it have been distracting. However, we strongly recommend to the reader to try solving as many of them as possible, since this is the most efficient way of grasping the subtleties of the concepts discussed in the book. The complete solutions of these more challenging problems are contained in the last section of the book.

Penetrating the inherently eclectic subject of Morse theory requires quite a varied background. The present book is addressed to a reader familiar with the basics of algebraic topology (fundamental group, singular (co)homology,

Poincaré duality, e.g., Chapters 0–3 of [Ha]) and the basics of differential geometry (vector fields and their flows, Lie and exterior derivative, integration on manifolds, basics of Lie groups and Riemannian geometry, e.g., Chapters 1–4 in [Ni]). In a very limited number of places we had to use less familiar technical facts, but we believe that the logic of the main arguments is not obscured by their presence.

Acknowledgments. This book grew out of notes I wrote for a one-semester graduate course in topology at the University of Notre Dame in the fall of 2005. I want to thank the attending students, Eduard Balreira, Daniel Cibotaru, Stacy Hoehn, Sasha Lyapina, for their comments questions and suggestions, which played an important role in smoothing out many rough patches in presentation. While working on these notes I had many enlightening conversations on Morse theory with my colleague Richard Hind. I want to thank him for calmly tolerating my frequent incursions into his office, and especially for the several of his comments and examples I have incorporated in the book.

Last, but not the least, I want thank my wife. Her support allowed me to ignore the “publish or perish” pressure of these fast times, and I could ruminate on the ideas in this book with joyous abandonment.

This work was partially supported by NSF grant DMS-0303601.

Notations and Conventions

- For every set A we denote by $\#A$ its cardinality.
- For $\mathbb{K} = \mathbb{R}, \mathbb{C}$, $r > 0$ and M a smooth manifold we denote by $\underline{\mathbb{K}}_M^r$ the trivial vector bundle $\mathbb{K}^r \times M \rightarrow M$.
- $i := \sqrt{-1}$. **Re** denotes the real part, and **Im** denotes the imaginary part.
- For every smooth manifold M we denote by TM the tangent bundle, by $T_x M$ the tangent space to M at $x \in M$ and by $T_x^* M$ the cotangent space at x .
- For every smooth manifold and any smooth submanifold $S \hookrightarrow M$ we denote by $T_S M$ the *normal bundle* of S in M defined as the quotient $T_S M := (TM)|_S / TS$. The *conormal bundle* of S in M is the bundle $T_S^* M \rightarrow S$ defined as the kernel of the restriction map $(T^* M)|_S \rightarrow T^* S$.
- $\text{Vect}(M)$ denotes the space of smooth vector fields on M .
- $\Omega^p(M)$ denotes the space of smooth p -forms on M , while $\Omega_{cpt}^p(M)$ the space of compactly supported smooth p -forms.
- If $F : M \rightarrow N$ is a smooth map between smooth manifolds we will denote its differential by DF or F_* . DF_x will denote the differential of F at $x \in M$ which is a linear map $DF_x : T_x M \rightarrow T_x N$. $F^* : \Omega^p(N) \rightarrow \Omega^p(M)$ is the pullback by F .
- $\pitchfork :=$ transverse intersection.
- $\sqcup :=$ disjoint union.
- For every $X, Y \in \text{Vect}(M)$ we denote by L_X the Lie derivative along X and by $[X, Y]$ the Lie bracket $[X, Y] = L_X Y$. i_X or $X \lrcorner$ denotes the contraction by X .
- We will orient the manifolds with boundary using the outer-normal -first convention.
- The total space of a fiber bundle will be oriented using the fiber-first convention.
- $\mathfrak{so}(n)$ denotes the Lie algebra of $SO(n)$, $\mathfrak{u}(n)$ denotes the Lie algebra of $U(n)$ etc.
- $\text{Diag}(c_1, \dots, c_n)$ denotes the diagonal $n \times n$ matrix with entries c_1, \dots, c_n .

Contents

Preface	VII
Notations and conventions	XI
1 Morse Functions	1
1.1 The Local Structure of Morse Functions	1
1.2 Existence of Morse Functions	17
2 The Topology of Morse Functions	23
2.1 Surgery, Handle Attachment, and Cobordisms	23
2.2 The Topology of Sublevel Sets	34
2.3 Morse Inequalities	46
2.4 Morse–Smale Dynamics	55
2.5 Morse–Floer Homology	65
2.6 Morse–Bott Functions	70
2.7 Min–Max Theory	74
3 Applications	87
3.1 The Cohomology of Complex Grassmannians	87
3.2 Lefschetz Hyperplane Theorem	92
3.3 Symplectic Manifolds and Hamiltonian Flows	99
3.4 Morse Theory of Moment Maps	117
3.5 S^1 -Equivariant Localization	135
4 Basics of Complex Morse Theory	151
4.1 Some Fundamental Constructions	152
4.2 Topological Applications of Lefschetz Pencils	156
4.3 The Hard Lefschetz Theorem	167
4.4 Vanishing Cycles and Local Monodromy	172
4.5 Proof of the Picard–Lefschetz formula	182
4.6 Global Picard–Lefschetz Formulæ	187

XIV Contents

5 Exercises and Solutions	193
5.1 Exercises	193
5.2 Solutions to Selected Exercises	209
References	235
Index	239

Morse Functions

In this first chapter we introduce the reader to the main characters of our story, namely the Morse functions, and we describe the properties which make them so useful. We describe their very special local structure (Morse lemma) and then we show that there are plenty of them around.

1.1 The Local Structure of Morse Functions

Suppose $F : M \rightarrow N$ is a smooth (i.e., C^∞) map between smooth manifolds. The differential of F defines for every $x \in M$ a linear map

$$DF_x : T_x M \rightarrow T_{F(x)} N.$$

Definition 1.1. (a) *The point $x \in M$ is called a critical point of F if*

$$\text{rank } DF_x < \min(\dim M, \dim N).$$

A point $x \in M$ is called a regular point of F if it is not a critical point. The collection of all critical points of F is called the critical set of F and is denoted by \mathbf{Cr}_F .

(b) *The point $y \in N$ is called a critical value of F if the fiber $F^{-1}(y)$ contains a critical point of F . A point $y \in N$ is called a regular value of F if it is not a critical value. The collection of all critical values of F is called the discriminant set of F and is denoted by Δ_F .*

(c) *A subset $S \subset N$ is said to be negligible if for every smooth open embedding $\Phi : \mathbb{R}^n \rightarrow N$, $n = \dim N$, the preimage $\Phi^{-1}(S)$ has Lebesgue measure zero in \mathbb{R}^n . \square*

Theorem 1.2 (Morse–Sard–Federer). *Suppose $F : M \rightarrow N$ is a smooth function. Then the Hausdorff dimension of the discriminant set Δ_F is at most*

$\dim N - 1$. In particular, the discriminant set is negligible in N . Moreover, if $F(M)$ has nonempty interior, then the set of regular values is dense in $F(M)$. \square

For a proof we refer to Federer [Fed, Theorem 3.4.3] or Milnor [M2].

Remark 1.3. (a) If M and N are real analytic manifolds and F is a proper real analytic map then we can be more precise. The discriminant set is a locally finite union of real analytic submanifolds of N of dimensions less than $\dim N$. Exercise 5.1 may perhaps explain why the set of critical values is called discriminant.

(b) The range of a smooth map $F : M \rightarrow N$ may have empty interior. For example, the range of the map $F : \mathbb{R}^3 \rightarrow \mathbb{R}^2$, $F(x, y, z) = (x, 0)$, is the x -axis of the Cartesian plane \mathbb{R}^2 . The discriminant set of this map coincides with the range. \square

Example 1.4. Suppose $f : M \rightarrow \mathbb{R}$ is a smooth function. Then $x_0 \in M$ is a critical point of f if and only if $df|_{x_0} = 0 \in T_{x_0}^*M$.

Suppose M is embedded in an Euclidean space E and $f : E \rightarrow \mathbb{R}$ is a smooth function. Denote by f_M the restriction of f to M . A point $x_0 \in M$ is a critical point of f_M if

$$\langle df, v \rangle = 0, \quad \forall v \in T_{x_0}M.$$

This happens if either x_0 is a critical point of f , or $df_{x_0} \neq 0$ and the tangent space to M at x_0 is contained in the tangent space at x_0 of the level set $\{f = f(x_0)\}$. If f happens to be a nonzero linear function, then all its level sets are hyperplanes perpendicular to a fixed vector \mathbf{u} , and $x_0 \in M$ is a critical point of f_M if and only if $\mathbf{u} \perp T_{x_0}M$, i.e., the hyperplane determined by f and passing through x_0 is tangent to M .

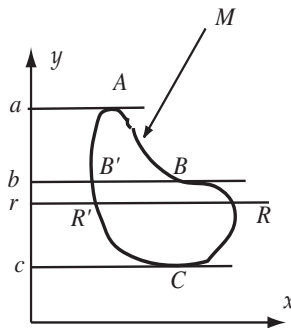

Fig. 1.1. The height function on a smooth curve in the plane.

In Figure 1.1 we have depicted a smooth curve $M \subset \mathbb{R}^2$. The points A, B, C are critical points of the linear function $f(x, y) = y$. The level sets of this function are horizontal lines and the critical points of its restriction to M are the points where the tangent space to the curve is horizontal. The points a, b, c on the vertical axis are critical values, while r is a regular value. \square

Example 1.5 (Robot arms: critical configurations). We begin in this example the study of the critical points of a smooth function which arises in the design of robot arms. We will discuss only a special case of the problem when the motion of the arm is constrained to a plane. For slightly different presentations we refer to the papers [Hau, KM, SV], which served as our sources of inspiration. The paper [Hau] discusses the most general version of this problem, when the motion of the arm is not necessarily constrained to a plane.

Fix positive real numbers $r_1, \dots, r_n > 0, n \geq 2$. A (planar) *robot arm* (or *linkage*) with n segments is a continuous curve in the Euclidean plane consisting of n line segments

$$s_1 = [J_0J_1], \quad s_2 = [J_1J_2], \dots, \quad s_n = [J_{n-1}J_n]$$

of lengths

$$\text{dist}(J_i, J_{i-1}) = r_i, \quad i = 1, 2, \dots, n.$$

We will refer to the vertices J_i as the *joints* of the robot arm. We assume that J_0 is fixed at the origin of the plane, and all the segments of the arm are allowed to rotate about the joints. Additionally, we require that the last joint be constrained to slide along the positive real semiaxis (see Figure 1.2).

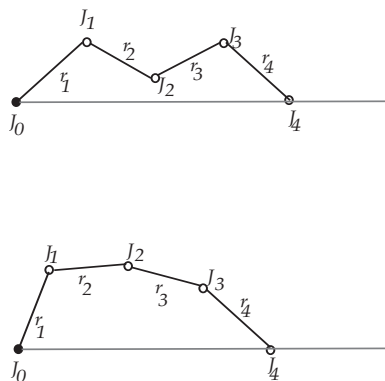

Fig. 1.2. A robot arm with four segments.

A (robot arm) configuration is a possible position of the robot arm subject to the above constraints. Mathematically a configuration is described by an

n -uple

$$\mathbf{z} = (z_1, \dots, z_n) \in \mathbb{C}^n$$

constrained by

$$|z_k| = 1, \quad k = 1, 2, \dots, n, \quad \mathbf{Im} \sum_{k=1}^n r_k z_k = 0, \quad \mathbf{Re} \sum_{k=1}^n r_k z_k > 0.$$

Visually, if $z_k = e^{i\theta_k}$, then θ_k measures the inclination of the k th segment of the arm. The position of k th joint J_k is described by the complex number $r_1 z_1 + \dots + r_k z_k$.

In Exercise 5.2 we ask the reader to verify that the space of configurations is a *smooth* hypersurface C of the n -dimensional manifold

$$M := \left\{ (\theta_1, \dots, \theta_n) \in (S^1)^n; \sum_{k=1}^n r_k \cos \theta_k > 0 \right\} \subset (S^1)^n,$$

described as the zero set of

$$\beta : M \rightarrow \mathbb{R}, \quad \beta(\theta_1, \dots, \theta_n) = \sum_{k=1}^n r_k \sin \theta_k = \mathbf{Im} \sum_{k=1}^n r_k z_k.$$

Consider the function $h : (S^1)^n \rightarrow \mathbb{R}$ defined by

$$h(\theta_1, \dots, \theta_n) = \sum_{k=1}^n r_k \cos \theta_k = \mathbf{Re} \sum_{k=1}^n r_k z_k.$$

Observe that for every configuration $\boldsymbol{\theta}$ the number $h(\boldsymbol{\theta})$ is the distance of the last joint from the origin. We would like to find the critical points of $h|_C$.

It is instructive to first visualize the level sets of h when $n = 2$ and $r_1 \neq r_2$, as it captures the general paradigm. For every configuration $\boldsymbol{\theta} = (\theta_1, \theta_2)$ we have

$$|r_1 - r_2| \leq h(\boldsymbol{\theta}) \leq r_1 + r_2.$$

For every $c \in (|r_1 - r_2|, r_1 + r_2)$, the level set $\{h = c\}$ consists of two configurations symmetric with respect to the x -axis. When $c = |r_1 \pm r_2|$ the level set consists of a single (critical) configuration. We deduce that the configuration space is a circle.

In general, a configuration $\boldsymbol{\theta} = (\theta_1, \dots, \theta_n) \in C$ is a critical point of the restriction of h to C if the differential of h at $\boldsymbol{\theta}$ is parallel to the differential at $\boldsymbol{\theta}$ of the constraint function β (which is the "normal" to this hypersurface). In other words, $\boldsymbol{\theta}$ is a critical point if and only if there exists a real scalar λ (Lagrange multiplier) such that

$$dh(\boldsymbol{\theta}) = \lambda d\beta(\boldsymbol{\theta}) \iff -r_k \sin \theta_k = \lambda r_k \cos \theta_k, \quad \forall k = 1, 2, \dots, n.$$

We discuss separately two cases.

A. $\lambda = 0$. In this case $\sin \theta_k = 0, \forall k$, that is, $\theta_k \in \{0, \pi\}$. If $z_k = e^{i\theta_k}$ we obtain the critical points

$$(z_1, \dots, z_n) = (\epsilon_1, \dots, \epsilon_n), \quad \epsilon_k = \pm 1, \quad \sum_{k=1}^n r_k \epsilon_k = \mathbf{Re} \sum_k r_k z_k > 0.$$

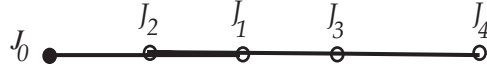

Fig. 1.3. A critical robot arm configuration.

B. $\lambda \neq 0$. We want to prove that this situation is impossible. We have

$$h(\boldsymbol{\theta}) = \sum_k r_k \cos \theta_k > 0$$

and thus

$$0 = \beta(\boldsymbol{\theta}) = \sum_k r_k \sin \theta_k = -\lambda \sum_k r_k \cos \theta_k \neq 0.$$

We deduce that the critical points of the function h are precisely the configurations $\boldsymbol{\zeta} = (\epsilon_1, \dots, \epsilon_n)$ such that $\epsilon_k = \pm 1$ and $\sum_{k=1}^n r_k \epsilon_k > 0$. The corresponding configurations are the positions of the robot arm when all segments are parallel to the x -axis (see Figure 1.3). The critical configuration $\boldsymbol{\zeta} = (1, 1, \dots, 1)$ corresponds to the global maximum of h when the robot arm is stretched to its full length. We can be even more precise if we make the following generic assumption:

$$\sum_{k=1}^n r_k \epsilon_k \neq 0, \quad \forall \epsilon_1, \dots, \epsilon_n \in \{1, -1\}. \tag{1.1}$$

The above condition is satisfied if for example the numbers r_k are linearly independent over \mathbb{Q} . This condition is also satisfied when the length of the longest segment of the arm is strictly greater than the sum of the lengths of the remaining segments.

The assumption (1.1) implies that for any choice of $\epsilon_k = \pm 1$ the sum $\sum_k r_k \epsilon_k$ is never zero. We deduce that half of all the possible choices of ϵ_k lead to a positive $\sum_k r_k \epsilon_k$, so that the number of critical points is $c(n) = 2^{n-1}$. \square

If M is a smooth manifold, X is a vector field on M , and f is a smooth function, then we define the derivative of f along X to be the function

$$Xf = df(X).$$

Lemma 1.6. *Suppose $f : M \rightarrow \mathbb{R}$ is a smooth function and $p_0 \in M$ is a critical point of f . Then for every vector fields X, X', Y, Y' on M such that*

$$X(p_0) = X'(p_0), \quad Y(p_0) = Y'(p_0),$$

we have

$$(XYf)(p_0) = (X'Y')f(p_0) = (YXf)(p_0).$$

Proof. Note first that

$$(XY - YX)f(p_0) = ([X, Y]f)(p_0) = df([X, Y])(p_0) = 0.$$

Since $(X - X')(p_0) = 0$, we deduce that

$$(X - X')g(p_0) = 0, \quad \forall g \in C^\infty(M).$$

Hence

$$(X - X')Yf(p_0) = 0 \implies (XYf)(p_0) = (X'Yf)(p_0).$$

Finally,

$$(X'Yf)(p_0) = (YX'f)(p_0) = (Y'X'f)(p_0) = (X'Y'f)(p_0). \quad \square$$

If p_0 is a critical point of the smooth function $f : M \rightarrow \mathbb{R}$, then we define the *Hessian* of f at p_0 to be the map

$$H_{f,p_0} : T_{p_0}M \times T_{p_0}M \rightarrow \mathbb{R}, \quad H_{f,p_0}(X_0, Y_0) = (XYf)(p_0),$$

where X, Y are vector fields on M such that $X(p_0) = X_0, Y(p_0) = Y_0$. The above lemma shows that the definition is independent of the choice of vector fields X, Y extending X_0 and Y_0 . Moreover, H_{f,p_0} is bilinear and symmetric.

Definition 1.7. *A critical point p_0 of a smooth function $f : M \rightarrow \mathbb{R}$ is called nondegenerate if its Hessian is nondegenerate, i.e.*

$$H_{f,p_0}(X, Y) = 0, \quad \forall Y \in T_{p_0}M \iff X = 0.$$

A smooth function is called a Morse function if all its critical points are nondegenerate. \square

Note that if we choose local coordinates (x^1, \dots, x^n) near p_0 such that $x^i(p_0) = 0, \forall i$, then any vector fields X, Y have a local description

$$X = \sum_i X^i \partial_{x^i}, \quad Y = \sum_j Y^j \partial_{x^j}$$

near p_0 , and then we can write

$$H_{f,p_0}(X, Y) = \sum_{i,j} h_{ij} X^i Y^j, \quad h_{ij} = (\partial_{x^i} \partial_{x^j} f)(p_0).$$

The critical point is nondegenerate if and only if $\det(h_{ij}) \neq 0$. For example, the point B in Figure 1.1 is a degenerate critical point.

The Hessian also determines a function defined in a neighborhood of p_0 ,

$$H_{f,p_0}(x) = \sum_{i,j} h_{ij} x^i x^j,$$

which appears in the Taylor expansion of f at p_0 ,

$$f(x) = f(p_0) + \frac{1}{2} H_{f,p_0}(x) + O(3).$$

Let us recall a classical fact of linear algebra.

If V is a real vector space of finite dimension n and $b : V \times V \rightarrow \mathbb{R}$ is a symmetric, bilinear nondegenerate map, then there exists at least one basis (e_1, \dots, e_n) such that for any $v = \sum_i v^i e_i$ we have

$$b(v, v) = -(|v^1|^2 + \dots + |v^\lambda|^2) + |v^{\lambda+1}|^2 + \dots + |v^n|^2.$$

The integer λ is independent of the basis of (e_i) , and we will call it the index of b . It can be defined equivalently as the largest integer ℓ such that there exists an ℓ -dimensional subspace V_- of V with the property that the restriction of b to V_- is negative definite.

Definition 1.8. *Suppose p_0 is a nondegenerate critical point of a smooth function $f : M \rightarrow \mathbb{R}$. Then its index, denoted by $\lambda(f, p_0)$, is defined to be the index of the Hessian H_{f,p_0} . \square*

If $f : M \rightarrow \mathbb{R}$ is a Morse function with finitely many critical points, then we define the *Morse polynomial* of f to be

$$P_f(t) = \sum_{p \in \mathbf{Cr}_f} t^{\lambda(f,p)} = \sum_{\lambda \geq 0} \mu_f(\lambda) t^\lambda.$$

Observe that $\mu_f(\lambda)$ is equal to the number of critical points of f of index λ . The coefficients of the Morse polynomial are known as the *Morse numbers* of the Morse function f .

Example 1.9. Consider the hypersurface $S \subset \mathbb{R}^3$ depicted in Figure 1.4. This hypersurface is diffeomorphic to the 2-sphere. The height function z on \mathbb{R}^3 restricts to a Morse function on S .

This Morse function has four critical points labeled A, B, C, D in Figure 1.4. Their Morse indices are

$$\lambda(A) = \lambda(B) = 2, \quad \lambda(C) = 1, \quad \lambda(D) = 0,$$

so that the Morse polynomial is

$$t^{\lambda(A)} + t^{\lambda(B)} + t^{\lambda(C)} + t^{\lambda(D)} = 2t^2 + t + 1. \quad \square$$

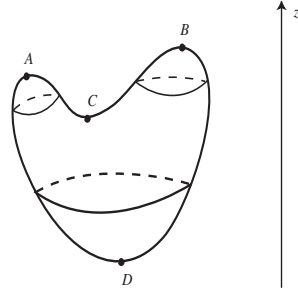

Fig. 1.4. A Morse function on the 2-sphere.

Example 1.10 (Robot arms: index computations). Consider again the setup in Example 1.5. We have a smooth function $h : C \rightarrow \mathbb{R}$, where

$$C = \left\{ (z_1, \dots, z_n) \in (S^1)^n; \operatorname{Re} \sum_k r_k z_k > 0, \operatorname{Im} \sum_k r_k z_k = 0 \right\},$$

and

$$h(z_1, \dots, z_n) = \operatorname{Re} \sum_k r_k z_k.$$

Under the assumption (1.1) this function has 2^{n-1} critical points ζ described by

$$\zeta = (\zeta_1, \dots, \zeta_n) = (\epsilon_1, \dots, \epsilon_n), \quad \epsilon_k = \pm 1, \quad \sum_k r_k \epsilon_k > 0.$$

We want to prove that h is a Morse function and compute its Morse polynomial. We write

$$\zeta_k = e^{i\varphi_k}, \quad \varphi_k \in \{0, \pi\}.$$

A point $\mathbf{z} = (e^{i\theta_1}, \dots, e^{i\theta_n}) \in C$ close to ζ is described by angular coordinates

$$\theta_k = \varphi_k + t_k, \quad |t_k| \ll 1,$$

satisfying the constraint

$$g(t_1, \dots, t_n) = \sum_{k=1}^n r_k \sin(\varphi_k + t_k) = 0.$$

Near ζ the function g has the Taylor expansion

$$g(t_1, \dots, t_n) = \sum_{k=1}^n \epsilon_k r_k t_k + O(3),$$

where $O(r)$ denotes an error term smaller than some constant multiple of $(|t_1| + \dots + |t_n|)^r$. From the implicit function theorem applied to the constraint equation $g = 0$ we deduce that we can choose (t_1, \dots, t_{n-1}) as local

coordinates on C near \mathbf{z} by regarding C as the graph of the smooth function t_n depending on the variables (t_1, \dots, t_{n-1}) . Using the Taylor expansion of t_n at

$$(t_1, \dots, t_{n-1}) = (0, \dots, 0)$$

we deduce (see Exercise 5.3)

$$t_n = - \sum_{k=1}^{n-1} \frac{\epsilon_k r_k t_k}{\epsilon_n r_n} + O'(2). \tag{1.2}$$

where $O'(r)$ denotes an error term smaller than some constant multiple of $(|t_1| + \dots + |t_{n-1}|)^r$.

Near ζ the function $h = \sum_{k=1}^n r_k \cos(\varphi_k + t_k)$ has the Taylor expansion

$$h = \sum_{k=1}^n \epsilon_k r_k - \frac{1}{2} \sum_{k=1}^n \epsilon_k r_k t_k^2 + O(4).$$

Using (1.2) we deduce that near $\zeta \in C$ we have the following expansion in the local coordinates: (t_1, \dots, t_{n-1})

$$h|_C = \sum_{k=1}^n \epsilon_k r_k - \frac{1}{2} \sum_{k=1}^{n-1} \epsilon_k r_k t_k^2 - \frac{1}{2} \epsilon_n r_n \left(\sum_{k=1}^{n-1} \frac{\epsilon_k r_k t_k}{\epsilon_n r_n} \right)^2 + O'(3).$$

We deduce that the Hessian of $h|_C$ at ζ can be identified with the restriction of the quadratic form

$$q(t_1, \dots, t_n) = - \sum_{k=1}^n \epsilon_k r_k t_k^2$$

to the subspace

$$T_\zeta C = \left\{ (t_1, \dots, t_n) \in \mathbb{R}^n; \sum_{k=1}^n \epsilon_k r_k t_k = 0 \right\}.$$

At this point we need the following elementary result.

Lemma 1.11. *Let $\mathbf{c} = (c_1, \dots, c_n) \in \mathbb{R}^n$ be such that*

$$c_1 \cdot c_2 \dots c_n \neq 0, \quad S := c_1 + \dots + c_n \neq 0.$$

Let $V := \{ \mathbf{t} \in \mathbb{R}^n; \mathbf{t} \perp \mathbf{c} \}$ and define the quadratic form

$$Q : \mathbb{R}^n \times \mathbb{R}^n \rightarrow \mathbb{R}, \quad Q(\mathbf{u}, \mathbf{v}) = \sum_{k=1}^n c_k u_k v_k.$$

Then the restriction of Q to V is nondegenerate and

$$\lambda(Q|_V) = \begin{cases} \lambda(Q) & S > 0, \\ \lambda(Q) - 1 & S < 0. \end{cases}$$

Proof. We may assume without any loss of generality that $|\mathbf{c}| = 1$. Denote by P_V the orthogonal projection onto V and set

$$L : \mathbb{R}^n \rightarrow \mathbb{R}^n, \quad L := \text{Diag}(c_1, \dots, c_n).$$

Then

$$Q(\mathbf{u}, \mathbf{v}) = (L\mathbf{u}, \mathbf{v}).$$

The restriction of Q to V is described by

$$Q|_V(\mathbf{v}_1, \mathbf{v}_2) = (P_V L \mathbf{v}_1, \mathbf{v}_2), \quad \forall \mathbf{v}_i \in V.$$

We deduce that $Q|_V$ is nondegenerate if and only if the linear operator $T = P_V L : V \rightarrow V$ has trivial kernel. Observe that $\mathbf{v} \in V$ belongs to $\ker T$ if and only if there exists a scalar $y \in \mathbb{R}$ such that

$$L\mathbf{v} = y\mathbf{c} \iff \mathbf{v} = y\boldsymbol{\delta}, \quad \boldsymbol{\delta} = (1, \dots, 1).$$

Since $(\mathbf{v}, \mathbf{c}) = 0$ and $(\boldsymbol{\delta}, \mathbf{c}) = \sum_{k=1}^n c_k \neq 0$ we deduce $y = 0$, so that $\mathbf{v} = 0$.

For $\mathbf{v} \in V$ and $y \in \mathbb{R}$ we have

$$(L(\mathbf{v} + y\boldsymbol{\delta}), \mathbf{v} + y\boldsymbol{\delta}) = (L\mathbf{v}, \mathbf{v}) + 2y(L\mathbf{v}, \boldsymbol{\delta}) + y^2(L\boldsymbol{\delta}, \boldsymbol{\delta}) = (L\mathbf{v}, \mathbf{v}) + y^2 S. \quad (1.3)$$

Suppose V_{\pm} is a maximal subspace of V , where $Q|_V$ is positive/negative definite, so that

$$V_+ + V_- = V \quad \left(\implies \dim V_+ + \dim V_- = \dim V = n - 1 \right).$$

Set

$$U_{\pm} = V_{\pm} \oplus \mathbb{R}\boldsymbol{\delta} = V_{\pm} \oplus \mathbb{R}\mathbf{c}.$$

Observe that

$$\dim U_{\pm} = \dim V_{\pm} + 1, \quad V_+ \oplus U_- = \mathbb{R}^n = U_+ \oplus V_-. \quad (1.4)$$

We now distinguish two cases.

A. $S > 0$. Using equation (1.3) we deduce that Q is positive definite on U_+ and negative definite on V_- . The equalities (1.4) imply that

$$\lambda(Q) = \dim V_- = \lambda(Q|_V).$$

B. $S < 0$. Using equation (1.3) we deduce that Q is positive definite on V_+ and negative definite on U_- . The equalities (1.4) imply that

$$\lambda(Q) = \lambda(Q|_V) + 1.$$

This completes the proof of Lemma 1.11. □

Returning to our index computation we deduce that at a critical configuration $\epsilon = (\epsilon_1, \dots, \epsilon_n)$ the Hessian of h is equal to the restriction of the quadratic form

$$Q = \sum_{k=1}^n c_k t_k^2, \quad c_k = -\epsilon_k r_k, \quad \sum_{k=1}^n c_k = -h(\epsilon) < 0,$$

to the orthogonal complement of \mathbf{c} . Lemma 1.11 now implies that this hessian is nondegenerate and its index is

$$\lambda(\epsilon) = \lambda_h(\epsilon) = \#\{k; \epsilon_k = 1\} - 1. \quad (1.5)$$

For different approaches to the index computation we refer to [Hau, SV].

If (1.1) is satisfied we can obtain more refined information about the Morse polynomial of h . For every binary vector $\epsilon \in \{-1, 1\}^n$ we define

$$\sigma(\epsilon) := \#\{k; \epsilon_k = 1\}, \quad \ell(\epsilon) = \sum_k \epsilon_k, \quad \rho(\epsilon) = \sum_k r_k \epsilon_k.$$

We deduce

$$\begin{aligned} 2\sigma(\epsilon) &= \sum_k \epsilon_k + \sum_k |\epsilon_k| = \ell(\epsilon) + n \\ \implies \lambda(\epsilon) &= \frac{1}{2}(n + \ell(\epsilon)) - 1. \end{aligned}$$

The set of critical points of h can be identified with the set

$$R_+ := \{\epsilon \in \{-1, 1\}^n; \rho(\epsilon) > 0\}.$$

Define

$$R_- = \{\epsilon; -\epsilon \in R_+\}.$$

Assumption (1.1) implies that

$$\{-1, 1\}^n = R_+ \sqcup R_-.$$

The Morse polynomial of h is

$$P_h(t) = \sum_{\epsilon \in R_+} t^{\lambda(\epsilon)} = t^{\frac{n}{2}-1} \sum_{\epsilon \in R_+} t^{\ell(\epsilon)/2}.$$

Define

$$L_h^+(t) := \sum_{\epsilon \in R_+} t^{\ell(\epsilon)/2}, \quad L_h^-(t) := \sum_{\epsilon \in R_-} t^{\ell(\epsilon)/2}.$$

Since $\ell(-\epsilon) = -\ell(\epsilon)$ we deduce

$$L_h^-(t) = L_h^+(t^{-1}).$$

On the other hand,

$$L_h^+(t) + L_h^-(t) = \sum_{\epsilon} (t^{1/2})^{\ell(\epsilon)} = (t^{1/2} + t^{-1/2})^n = t^{-n/2}(t+1)^n.$$

Hence

$$L_h^+(t) + L_h(t^{-1}) = t^{-n/2}(t+1)^n.$$

Since

$$L_h^+(t) = t^{-n/2+1}P_h(t),$$

we deduce

$$t^{-n/2+1}P_h(t) + t^{n/2-1}P_h(t^{-1}) = t^{-n/2}(t+1)^n,$$

so that

$$tP_h(t) + t^{n-1}P_h(t^{-1}) = (t+1)^n. \quad (1.6)$$

Observe that $t^{n-1}P(t^{-1})$ is the Morse polynomial of $-h$, so that

$$tP_h(t) + P_{-h}(t) = (t+1)^n. \quad (1.7)$$

If

$$P_h(t) = a_0 + a_1t + \dots + a_{n-1}t^{n-1},$$

then we deduce from (1.6) that

$$a_k + a_{n-2-k} = \binom{n}{k+1}, \quad \forall k = 1, \dots, n-2, \quad a_{n-1} = 1. \quad \square$$

Let us return to our general study of Morse functions. The key algebraic reason for their effectiveness in topological problems stems from their local rigidity. More precisely, the Morse functions have a very simple local structure: up to a change of coordinates all Morse functions are quadratic. This is the content of our next result, commonly referred to as the *Morse lemma*.

Theorem 1.12 (Morse). *Suppose $f : M \rightarrow \mathbb{R}$ is a smooth function, $m = \dim M$, and p_0 is a nondegenerate critical point of f . Then there exists an open neighborhood U of p_0 and local coordinates (x^1, \dots, x^m) on U such that*

$$x^i(p_0) = 0, \quad \forall i = 1, \dots, m \quad \text{and} \quad f(x) = f(p_0) + \frac{1}{2}H_{f,p_0}(x).$$

In other words, f is described in these coordinates by a quadratic polynomial.

Proof. We use the approach in [AGV1, §6.4] based on the *homotopy method*. This has the advantage that it applies to more general situations. Assume for simplicity that $f(p_0) = 0$.

Fix a diffeomorphism Φ from \mathbb{R}^m onto an open neighborhood N of p_0 such that $\Phi(0) = p_0$. This diffeomorphism defines coordinates (x^i) on N such that $x^i(p_0) = 0, \forall i$, and we set $\varphi(x) = f(\Phi(x))$. For $t \in [0, 1]$ define $\varphi_t : \mathbb{R}^m \rightarrow \mathbb{R}$ by

$$\varphi_t(x) = (1-t)\varphi(x) + tQ(x) = Q(x) + (1-t)(\varphi(x) - Q(x)),$$

where

$$Q(x) = \frac{1}{2} \sum_{i,j} \frac{\partial^2 \varphi}{\partial x^i \partial x^j}(0) x^i x^j.$$

We seek an open neighborhood $U \subset \Phi^{-1}(N)$ of $0 \in \mathbb{R}^m$ and a one-parameter family of embeddings $\Psi_t : U \hookrightarrow \mathbb{R}^m$ such that

$$\Psi_t(0) = 0, \quad \varphi_t \circ \Psi_t \equiv \varphi \quad \text{on } U \quad \forall t \in [0, 1]. \quad (1.8)$$

Such a family is uniquely determined by the t -dependent vector field

$$V_t(x) := \frac{d}{dt} \Psi_t(x).$$

More precisely, the path $t \mapsto \Psi_t(x) \in \mathbb{R}^m$ is the unique solution of the initial value problem

$$\dot{\gamma}(t) = V_t(\gamma(t)) \quad \forall t, \quad \gamma(0) = x.$$

Differentiating (1.8) with respect to t , we deduce the *homology equation*

$$\dot{\varphi}_t \circ \Psi_t + (V_t \varphi_t) \circ \Psi_t = 0 \iff Q - \varphi = V_t \varphi_t \quad \text{on } \Psi_t(U), \quad \forall t \in [0, 1]. \quad (1.9)$$

If we find a vector field V_t satisfying $V_t(0) = 0 \quad \forall t \in [0, 1]$ and (1.9) on a neighborhood W of 0, then

$$\mathcal{N} = \bigcap_{t \in [0, 1]} \Psi_t^{-1}(W)$$

is a neighborhood¹ of 0, and we deduce that Ψ_t satisfies (1.8) on \mathcal{N} . To do this we need to introduce some terminology.

Two smooth functions f, g defined in a neighborhood of $0 \in \mathbb{R}^m$ are said to be equivalent at 0 if there exists a neighborhood U of 0 such that $f|_U = g|_U$. The equivalence class of such a function f is called the *germ of the function* at 0 and it is denoted by $[f]$. We denote by \mathcal{E} the collection of germs at 0 of smooth functions. It is naturally an \mathbb{R} -algebra. The evaluation map

$$C^\infty \ni f \mapsto f(0) \in \mathbb{R}$$

induces a surjective morphism of rings $\mathcal{E} \rightarrow \mathbb{R}$. Its kernel is therefore a *maximal ideal* in \mathcal{E} , which we denote by \mathfrak{m} . It is easy to see that \mathcal{E} is a local ring, since for any function f such that $f(0) \neq 0$, the inverse $1/f$ is smooth near zero.

¹ This happens because the condition $V_t(0) = 0 \quad \forall t$ implies that there exists $r > 0$ with the property that $\Psi_t(x) \in W, \forall |x| < r, \forall t \in [0, 1]$. Loosely speaking, if a point x is not very far from the stationary point 0 of the flow Ψ_t , then in one second it cannot travel very far along this flow.

Lemma 1.13 (Hadamard). *The ideal \mathfrak{m} is generated by the germs of the coordinate functions x^i .*

Proof. It suffices to show that $\mathfrak{m} \subset \sum_i x^i \mathcal{E}$.

Consider a germ in \mathfrak{m} represented by the smooth function f defined in an open ball $B_r(0)$. Then for every $x \in B_r(0)$ we have

$$f(x) = f(x) - f(0) = \int_0^1 \frac{d}{ds} f(sx) ds = \sum_i x^i \underbrace{\int_0^1 \frac{\partial f}{\partial x^i}(sx) ds}_{:=u_i}.$$

This proves that $[f] = \sum_i [x^i][u_i]$. □

For every multi-index $\alpha = (\alpha_1, \dots, \alpha_m) \in \mathbb{Z}_{\geq 0}^m$ we set

$$|\alpha| = \sum_i \alpha_i, \quad x^\alpha = (x^1)^{\alpha_1} \dots (x^m)^{\alpha_m}, \quad D^\alpha = \frac{\partial^{|\alpha|}}{(\partial x^1)^{\alpha_1} \dots (\partial x^m)^{\alpha_m}}.$$

Lemma 1.14. *If $(D^\alpha f)(0) = 0$ for all $|\alpha| < k$ then $[f] \in \mathfrak{m}^k$. In particular $[\varphi] \in \mathfrak{m}^2$, $\varphi - Q \in \mathfrak{m}^3$.*

Proof. We argue by induction on $k \geq 1$. The case $k = 1$ follows from Hadamard's lemma. Suppose now that $(D^\alpha f)(0) = 0$ for all $|\alpha| < k$. By induction we deduce that $[f] \in \mathfrak{m}^{k-1}$, so that

$$f = \sum_{|\alpha|=k-1} x^\alpha u_\alpha, \quad u_\alpha \in \mathcal{E}.$$

Hence, for any multi-index β such that $|\beta| = k - 1$, we have

$$D^\beta f = D^\beta \left(\sum_{|\alpha| \leq k-1} x^\alpha u_\alpha \right) \in u_\beta + \mathfrak{m}.$$

In other words,

$$D^\beta f - u_\beta \in \mathfrak{m}, \quad \forall |\beta| = k - 1.$$

Since $(D^\beta f)(0) = 0$, we deduce from Hadamard's lemma that $D^\beta f \in \mathfrak{m}$ so that $u_\beta \in \mathfrak{m}$ for all β . □

Denote by J_φ the ideal in \mathcal{E} generated by the germs at 0 of the partial derivatives $\partial_{x^i} \varphi$, $i = 1, \dots, m$. It is called the *Jacobian ideal* of φ at 0. Since 0 is a critical point of φ , we have $J_\varphi \subset \mathfrak{m}$. Because 0 is a *nondegenerate* critical point, we have an even stronger result.

Lemma 1.15 (Key lemma). $J_\varphi = \mathfrak{m}$.

Proof. We present a proof based on the implicit function theorem. Consider the smooth map

$$y = d\varphi : \mathbb{R}^m \rightarrow \mathbb{R}^m, \quad y = (y^1(x), \dots, y^m(x)), \quad y^i = \partial_i \varphi.$$

Then

$$y(0) = 0, \quad \frac{\partial y}{\partial x}|_{x=0} = H_{\varphi,0}.$$

Since $\det H_{\varphi,0} \neq 0$, we deduce from the implicit function theorem that y is a local diffeomorphism. Hence its components y^i define local coordinates near $0 \in \mathbb{R}^m$ such that $y^i(0) = 0$. We can thus express the x^i 's as smooth functions of y^j 's, $x^i = x^i(y^1, \dots, y^m)$.

On the other hand, $x^i(y)|_{y=0} = 0$, so we can conclude from the Hadamard Lemma that there exist smooth functions $u_j^i = u_j^i(y)$ such that

$$x^i = \sum_j u_j^i y^j \implies x^i \in J_{\varphi}, \quad \forall i. \quad \square$$

Set $\delta := \varphi - Q$, so that $\varphi_t = \varphi - t\delta$. We rewrite the homology equation as

$$V_t \cdot (\varphi - t\delta) = -\delta.$$

For every $g \in \mathcal{E}$ we consider the “initial value” problem

$$V_t(0) = 0, \quad \forall t \in [0, 1], \quad (\mathbf{I})$$

$$V_t \cdot (\varphi - t\delta) = g, \quad \forall t \in [0, 1]. \quad (\mathbf{H}_g)$$

Lemma 1.16. *For every $g \in \mathfrak{m}$ there exists a smooth vector field V_t satisfying (\mathbf{H}_g) for any $t \in [0, 1]$. Moreover, if $g \in \mathfrak{m}^2$ we can find a solution V_t of (\mathbf{H}_g) satisfying the initial condition (\mathbf{I}) as well.*

Proof. We start with some simple observations. Observe that if $V_t(g_i)$ is a solution of (\mathbf{H}_{g_i}) , $i = 0, 1$, and $u_i \in \mathcal{E}$, then $u_0 V_t(g_0) + u_1 V_t(g_1)$ is a solution of $(\mathbf{H}_{u_0 g_0 + u_1 g_1})$. Since every $g \in \mathfrak{m}$ can be written as a linear combination

$$g = \sum_{i=1}^m x^i u_i, \quad u_i \in \mathcal{E},$$

it suffices to find solutions V_t^i of (\mathbf{H}_{x^i}) .

Using the key lemma we can find $a_{ij} \in \mathcal{E}$ such that

$$x^i = \sum_j a_{ij} \partial_j \varphi, \quad \partial_j := \partial_{x^j}.$$

We can write this in matrix form as

$$x = A(x) \nabla \varphi \iff x = A(x) \nabla (\varphi - t\delta) + tA(x) \nabla \delta. \quad (1.11)$$

Lemma 1.14 implies $\delta \in \mathfrak{m}^3$, so that $\partial_i \delta \in \mathfrak{m}^2$, $\forall i$. Thus we can find $b_{ij} \in \mathfrak{m}$ such that

$$\partial_i \delta = \sum_j b_{ij} x^j,$$

or in matrix form,

$$\nabla \delta = Bx, \quad B(0) = 0.$$

Substituting this in (1.11), we deduce

$$(\mathbb{1}_{\mathbb{R}^m} - tA(x)B(x))x = A(x)\nabla(\varphi - t\delta).$$

Since $B(0) = 0$, we deduce that $(\mathbb{1}_{\mathbb{R}^m} - tA(x)B(x))$ is invertible² for every $t \in [0, 1]$ and every sufficiently small x . We denote by $C_t(x)$ its inverse, so that we obtain

$$x = C_t(x)A(x)\nabla(\varphi - t\delta).$$

If we denote by $V_j^i(t, x)$ the (i, j) entry of $C_t(x)A(x)$, we deduce

$$x^i = \sum_j V_j^i(t, x)\partial_j(\varphi - t\delta),$$

so

$$V_t^i = \sum_j V_j^i(t, x)\partial_j$$

is a solution of (\mathbf{H}_{x^i}) . If $g = \sum_i g_i x^i \in \mathfrak{m}$, then $\sum_i g_i V_t^i$ is a solution of (\mathbf{H}_g) . If additionally $g \in \mathfrak{m}^2$, then we can choose the previous g_i to be in \mathfrak{m} . Then $\sum_i g_i V_t^i$ is a solution of (\mathbf{H}_g) satisfying the initial condition (\mathbf{I}) . \square

Now observe that since $\delta \in \mathfrak{m}^3 \subset \mathfrak{m}^2$, we can find a solution V_t of $\mathbf{H}_{-\delta}$ satisfying the “initial” condition (\mathbf{I}) . This vector field is then a solution of the homology equations (1.9). This completes the proof of Theorem 1.12. \square

Corollary 1.17 (Morse lemma). *If p_0 is a nondegenerate critical point of index λ of a smooth function $f : M \rightarrow \mathbb{R}$, then there exist local coordinates $(x^i)_{1 \leq i \leq m}$ near p_0 such that $x^i(p_0) = 0$, $\forall i$, and in these coordinates we have the equality*

$$f = f(p_0) - \sum_{i=1}^{\lambda} (x^i)^2 + \sum_{j=\lambda+1}^m (x^j)^2. \quad \square$$

We will refer to coordinates with the properties in the Morse lemma as *coordinates adapted to the critical point*. If (x^1, \dots, x^m) are such coordinates, we will often use the notation

² The reader familiar with the basics of commutative algebra will most certainly recognize that this step of the proof is in fact Nakayama’s lemma in disguise.

$$x = (x_-, x_+), \quad x_- = (x^1, \dots, x^\lambda), \quad x_+ = (x^{\lambda+1}, \dots, x^m),$$

$$f = f(p_0) - |x_-|^2 + |x_+|^2.$$

1.2 Existence of Morse Functions

The second key reason for the topological versatility of Morse functions is their abundance. It turns out that they form a dense open subset in the space of smooth functions. The goal of this section is to prove this claim.

The strategy we employ is very easy to describe. We will produce families of smooth functions $f_\lambda : M \rightarrow \mathbb{R}$, depending smoothly on the parameter $\lambda \in A$, where A is a smooth finite dimensional manifold. We will then produce a smooth map $\pi : Z \rightarrow A$ such that f_λ is a Morse function for every regular value of π . Sard's theorem will then imply that f_λ is a Morse function for most λ 's.

Suppose M is a connected, smooth, m -dimensional manifold. According to the Whitney embedding theorem (see, e.g., [W, IV.A]) we can assume that M is embedded in an Euclidean vector space E of dimension $n \leq 2m + 1$. We denote the metric on E by (\bullet, \bullet) . Suppose A is a smooth manifold and $F : A \times E \rightarrow \mathbb{R}$ is a smooth function. We regard F as a smooth family of functions

$$F_\lambda : E \rightarrow \mathbb{R}, \quad F_\lambda(x) = F(\lambda, x), \quad \forall (\lambda, x) \in A \times E.$$

We set

$$f := F|_{A \times M}, \quad f_\lambda := F_\lambda|_M.$$

Let $x \in M$. There is a natural surjective linear map $P_x : E^* \rightarrow T_x^*M$ which associates to each linear functional on E its restriction to $T_xM \subset E$. In particular, we have an equality

$$df_\lambda(x) = P_x dF_\lambda(x).$$

For every $x \in M$ we have a smooth partial differential map

$$\partial^x f : A \rightarrow T_x^*M, \quad \lambda \mapsto df_\lambda(x).$$

Definition 1.18. (a) We say that the family $F : A \times E \rightarrow \mathbb{R}$ is sufficiently large relative to the submanifold $M \hookrightarrow E$ if the following hold:

- $\dim A \geq \dim M$.
- For every $x \in M$, the point $0 \in T_x^*M$ is a regular value for $\partial^x f$.

(b) We say that F is large if for every $x \in E$ the partial differential map

$$\partial^x F : \Lambda \rightarrow E^*, \quad \lambda \mapsto dF_\lambda(x)$$

is a submersion, i.e., its differential at any $\lambda \in \Lambda$ is surjective. \square

Lemma 1.19. *If $F : \Lambda \times E \rightarrow \mathbb{R}$ is large, then it is sufficiently large relative to any submanifold $M \hookrightarrow E$.*

Proof. From the equality $\partial^x f = P_x \partial^x F$ we deduce that $\partial^x f$ is a submersion as a composition of two submersions. In particular, it has no critical values. \square

Example 1.20. (a) Suppose $\Lambda = E^*$ and $H : E^* \times E \rightarrow \mathbb{R}$,

$$H(\lambda, x) = \lambda(x), \quad \forall (\lambda, x) \in E^* \times E.$$

Using the metric identification we deduce that

$$d_x H_\lambda = \lambda, \quad \forall \lambda \in E^*.$$

Hence

$$\partial^x H : E^* \rightarrow T_x^* E = E^*$$

is the identity map and thus it is a submersion. Hence H is a large family.

(b) Suppose E is a Euclidean vector space with metric (\bullet, \bullet) , $\Lambda = E$, and $R : E \times E \rightarrow \mathbb{R}$,

$$R(\lambda, x) = \frac{1}{2}|x - \lambda|^2.$$

Then R is large. To see this, denote by $\dagger : E \rightarrow E^*$ the metric duality. Note that

$$d_x R_\lambda = (x - \lambda)^\dagger,$$

and the map $E \ni \lambda \mapsto (x - \lambda)^\dagger \in E^*$ is an affine isomorphism. Thus R is a large family.

(c) Suppose E is an Euclidean space. Denote by Λ the space of positive definite symmetric endomorphisms $A : E \rightarrow E$ and define

$$F : \Lambda \times E \rightarrow \mathbb{R}, \quad \Lambda \times E \ni (A, x) \mapsto \frac{1}{2}(Ax, x).$$

Observe that $\partial^x F : \Lambda \rightarrow E$ is given by

$$\partial^x F(A) = Ax, \quad \forall A \in \Lambda.$$

If $x \neq 0$ then $\partial^x F$ is onto. This shows that F is sufficiently large relative to any submanifold of E not passing through the origin. \square

Theorem 1.21. *If the family $F : \Lambda \times E \rightarrow \mathbb{R}$ is sufficiently large relative to the submanifold $M \hookrightarrow E$, then there exists a negligible set Λ_∞ such that for all $\lambda \in \Lambda \setminus \Lambda_\infty$ the function $f_\lambda : M \rightarrow \mathbb{R}$ is a Morse function.*

Proof. We will carry the proof in several steps.

Step 1. We assume that M is *special*, i.e., there exist *global* coordinates

$$(x^1, \dots, x^n)$$

on E (not necessarily linear coordinates) such that M can be identified with an open subset W of the coordinate “plane”

$$\{x^{m+1} = \dots = x^n = 0\}.$$

For every $\lambda \in \Lambda$ we can then regard f_λ as a function $f_\lambda : W \rightarrow \mathbb{R}$ and its differential as a function

$$\varphi_\lambda : W \rightarrow \mathbb{R}^m, \quad w = (x^1, \dots, x^m) \mapsto \varphi_\lambda(w) = (\partial_{x^1} f_\lambda(w), \dots, \partial_{x^m} f_\lambda(w)).$$

A point $w \in W$ is a nondegenerate critical point of f_λ if

$$\varphi_\lambda(w) = 0 \in \mathbb{R}^m$$

and

the differential $D\varphi_\lambda : T_w W \rightarrow \mathbb{R}^m$ is bijective.

We deduce that f_λ is a Morse function if and only if 0 is a regular value of φ_λ . Consider now the function

$$\Phi : \Lambda \times W \rightarrow \mathbb{R}^m, \quad \Phi(\lambda, w) = \varphi_\lambda(w).$$

The condition that the family be sufficiently large is now needed to prove the following fact.

Lemma 1.22. *$0 \in \mathbb{R}^m$ is a regular value of Φ , i.e., for every $(\lambda, w) \in \Phi^{-1}(0)$ the differential $D\Phi : T_{(\lambda, w)} \Lambda \times W \rightarrow \mathbb{R}^m$ is onto.*

To keep the flow of arguments uninterrupted we will present the proof of this result after we have completed the proof of the theorem. We deduce that

$$Z = \Phi^{-1}(0) = \{(\lambda, w) \in \Lambda \times W; \varphi_\lambda(w) = 0\}.$$

The natural projection $\pi : \Lambda \times W \rightarrow \Lambda$ induces a smooth map $\pi : Z \rightarrow \Lambda$. We have the following key observation.

Lemma 1.23. *If λ is a regular value of $\pi : Z \rightarrow \Lambda$, then 0 is a regular value of φ_λ , i.e., f_λ is a Morse function.*

Proof. Suppose λ is a regular value of π . If λ does not belong to $\pi(Z)$ the function f_λ has no critical points on M , and in particular, it is a Morse function.

Thus, we have to prove that for every $w \in W$ such that $\varphi_\lambda(w) = 0$, the differential $D\varphi_\lambda : T_w W \rightarrow \mathbb{R}^m$ is surjective. Set

$$T_1 := T_\lambda A, \quad T_2 = T_w W, \quad V = \mathbb{R}^m,$$

$$D_1 : D_\lambda \Phi : T_1 \rightarrow V, \quad D_2 = D_w \Phi : T_2 \rightarrow V.$$

Note that $D\Phi = D_1 + D_2$, $z = (\lambda, w) \in Z$, and

$$T_z Z = \ker(D_1 + D_2 : T_1 \oplus T_2 \rightarrow V).$$

The lemma is then a consequence of the following linear algebra fact.

• *Suppose T_1, T_2, V are finite dimensional real vector spaces and*

$$D_i : T_i \rightarrow V, \quad i = 1, 2,$$

are linear maps such that $D_1 + D_2 : T_1 \oplus T_2 \rightarrow V$ is surjective and the restriction of the natural projection

$$P : T_1 \oplus T_2 \rightarrow T_1$$

to $K = \ker(D_1 + D_2)$ is surjective. Then D_2 is surjective.

Indeed, let $v \in V$. Then there exists $(t_1, t_2) \in T_1 \oplus T_2$ such that $v = D_1 t_1 + D_2 t_2$. On the other hand, since $P : K \rightarrow T_1$ is onto, there exists $t'_2 \in T_2$ such that $(t_1, t'_2) \in K$. Note that

$$v = D_1 t_1 + D_2 t_2 - (D_1 t_1 + D_2 t'_2) = D_2(t_2 - t'_2) \implies v \in \mathbf{Im} D_2. \quad \square$$

Using the Morse–Sard–Federer theorem we deduce that the set $A_M \subset A$ of critical values of $\pi : Z \rightarrow A$ is negligible, i.e., it has measure zero (see Definition 1.1). Thus, for every $\lambda \in A \setminus A_M$ the function $f_\lambda : M \rightarrow \mathbb{R}$ is a Morse function. This completes Step 1.

Step 2. M is general. We can then find a countable open cover $(M_k)_{k \geq 1}$ of M such that M_k is special $\forall k \geq 1$. We deduce from Step 1 that for every $k \geq 1$ there exists a negligible set $A_k \subset A$ such that for every $\lambda \in A \setminus A_k$ the restriction of f_λ to M_k is a Morse function. Set

$$A_\infty = \bigcup_{k \geq 1} A_k.$$

Then A_∞ is negligible, and for every $\lambda \in A \setminus A_\infty$ the function $f_\lambda : M \rightarrow \mathbb{R}$ is a Morse function. The proof of the theorem will be completed as soon as we prove Lemma 1.22.

Proof of Lemma 1.22. We have to use the fact that the family F is sufficiently large relative to M . This condition is equivalent to the fact that if (λ_0, w_0) is such that $\varphi_{\lambda_0}(w_0) = 0$, then the differential

$$D_\lambda \Phi = \frac{\partial}{\partial \lambda} \Big|_{\lambda=\lambda_0} df_\lambda(w_0) : T_{\lambda_0} A \rightarrow \mathbb{R}^m$$

is onto. A fortiori, the differential $D\Phi : T_{(\lambda_0, w_0)}(A \times W) \rightarrow \mathbb{R}^m$ is onto. \square

Definition 1.24. A continuous function $g : M \rightarrow \mathbb{R}$ is called *exhaustive* if all the sublevel sets $\{g \leq c\}$ are compact. \square

Using Lemma 1.19 and Example 1.20 we deduce the following result.

Corollary 1.25. Suppose M is a submanifold of the Euclidean space E not containing the origin. Then for almost all $v \in E^*$, almost all $p \in E$, and almost any positive symmetric endomorphism A of E the functions

$$h_v, r_p, q_A : M \rightarrow \mathbb{R},$$

defined by

$$h_v(x) = v(x), \quad r_p(x) = \frac{1}{2}|x - p|^2, \quad q_A(x) = \frac{1}{2}(Ax, x),$$

are Morse functions. Moreover, if M is closed as a subset of E then the functions r_p and q_A are exhaustive. \square

Remark 1.26. (a) The Whitney embedding theorem states something stronger: any smooth manifold of dimension m can be embedded as a *closed* subset of an Euclidean space of dimension at most $2m + 1$. We deduce that any smooth manifold admits *exhaustive* Morse functions.

(b) Note that an exhaustive smooth function satisfies the *Palais–Smale condition*: any sequence $x_n \in M$ such that $f(x_n)$ is bounded from above and $|df(x_n)_g| \rightarrow 0$ contains a subsequence convergent to a critical point of f . Here $|df(x)_g|$ denotes the length of $df(x) \in T_x^*M$ with respect to some fixed Riemannian metric on M . \square

Definition 1.27. A Morse function $f : M \rightarrow \mathbb{R}$ is called *resonant* if there exist two distinct critical points p, q corresponding to the same critical value, i.e., $f(p) = f(q)$. If different critical points correspond to different critical values then f is called *nonresonant*³. \square

³ R. Thom refers to our non-resonant Morse functions as *excellent*.

It is possible that a Morse function f constructed in this corollary may be resonant. We want to show that any Morse function can be arbitrarily well approximated in the C^2 -topology by nonresonant ones.

Consider a smooth function $\eta : [0, \infty) \rightarrow [0, 1]$ satisfying the conditions

$$\eta(0) = 1, \quad \eta(t) = 0, \quad \forall t \geq 2, \quad -1 \leq \eta'(t) \leq 0, \quad \forall t \geq 0.$$

We set

$$\eta_\varepsilon(t) = \varepsilon^3 \eta(\varepsilon^{-1}t).$$

Observe that

$$\eta_\varepsilon(0) = \varepsilon, \quad -\varepsilon^2 \leq \eta'_\varepsilon(t) \leq 0.$$

Suppose $f : M \rightarrow \mathbb{R}$ is a smooth function and p is a nondegenerate critical point of f , $f(p) = c$. Fix coordinates $x = (x_-, x_+)$ adapted to p . Hence

$$f = c - |x_-|^2 + |x_+|^2, \quad \forall x \in U_\varepsilon = \{|x_-|^2 + |x_+|^2 < 2\varepsilon\}.$$

Set $u_\pm = |x_\pm|^2$, $u = u_- + u_+$ and define

$$f_{\pm\varepsilon} = f_{\pm\varepsilon,p} = f + \pm\eta_\varepsilon(u) = c - u_- + u_+ + \eta_\varepsilon(u).$$

Then $f = f_{\pm\varepsilon}$ on $X \setminus U_\varepsilon$, while along U_ε we have

$$df_{\pm\varepsilon} = (\eta'_\varepsilon - 1)du_- + (\eta'_\varepsilon + 1)du_+.$$

This proves that the only critical point of $f_{\pm\varepsilon}|_{U_\varepsilon}$ is $x = 0$. Thus $f_{\pm\varepsilon,p}$ has the same critical set as f , and

$$\|f - f_{\pm\varepsilon}\|_{C^2} \leq \varepsilon, \quad f_{\pm\varepsilon}(p) = f(p) \pm \varepsilon^3, \quad f_{\pm\varepsilon}(q) = f(q), \quad \forall q \in \mathbf{Cr}_f \setminus \{p\}.$$

Iterating this procedure, we deduce the following result.

Proposition 1.28. *Suppose $f : M \rightarrow \mathbb{R}$ is a Morse function on the compact manifold M . Then there exists a sequence of nonresonant Morse functions $f_n : M \rightarrow \mathbb{R}$ with the properties*

$$\mathbf{Cr}_{f_n} = \mathbf{Cr}(f), \quad \forall n, \quad f_n \xrightarrow{C^2} f, \quad \text{as } n \rightarrow \infty. \quad \square$$

The Topology of Morse Functions

The present chapter is the heart of Morse *theory*, which is based on two fundamental principles. The “weak” Morse principle states that as long as the real parameter t varies in an interval containing only regular values of a smooth function $f : M \rightarrow \mathbb{R}$, then the topology of the sublevel set $\{f \leq t\}$ is independent of t . We can turn this on its head and state that a change in the topology of $\{f \leq t\}$ is an indicator of the presence of a critical point.

The “strong” Morse principle describes precisely the changes in the topology of $\{f \leq t\}$ as t crosses a critical value of f . These changes are known in geometric topology as surgery operations, or handle attachments.

The surgery operations are more complex than they first appear, and we thought it wise to devote an entire section to this topic. It will give the reader a glimpse at the potential “zoo” of smooth manifolds that can be obtained by an iterated application of these operations.

2.1 Surgery, Handle Attachment, and Cobordisms

To formulate the central results of Morse theory we need to introduce some topological terminology. Denote by \mathbb{D}^k the k -dimensional, *closed* unit disk and by $\mathring{\mathbb{D}}^k$ its interior. We will refer to \mathbb{D}^k as the *standard k -cell*. The cell attachment technique is one of the most versatile methods of producing new topological spaces out of existing ones.

Given a topological space X and a continuous map $\varphi : \partial\mathbb{D}^k \rightarrow X$, we can attach a k -cell to X to form the topological space $X \cup_{\varphi} \mathbb{D}^k$. The compact spaces obtained by attaching finitely many cells to a point are homotopy equivalent to finite *CW*-complexes. We would like to describe a related operation in the more restricted category of *smooth* manifolds.

We begin with the operation of *surgery*. Suppose M is a smooth m -dimensional manifold. The operation of surgery requires several additional data:

- an embedding $S \hookrightarrow M$ of the standard k -dimensional sphere S^k , $k < m$, with trivializable normal bundle $T_S M$;
- a *framing* of the normal bundle $T_S M$, i.e. a bundle isomorphism

$$\varphi : T_S M \rightarrow \underline{\mathbb{R}}_S^{m-k} = \mathbb{R}^{m-k} \times S.$$

Equivalently, a framing of S defines an isotopy class of embeddings

$$\varphi : \mathbb{D}^{m-k} \times S^k \rightarrow M \text{ such that } \varphi(\{0\} \times S^k) = S.$$

Set $U := \varphi(\mathring{\mathbb{D}}^{m-k} \times S^k)$. Then U is a tubular neighborhood of S in M . We can now define a new *topological* manifold $M(S, \varphi)$ by removing U and then gluing instead $\hat{U} = S^{m-k-1} \times \mathbb{D}^{k+1}$ along $\partial U = \partial(M \setminus U)$ via the identifications

$$\partial \hat{U} \xrightarrow{\varphi} \partial U = \partial(M \setminus U).$$

For every $e_0 \in \partial \mathbb{D}^{m-k} = S^{m-k-1}$, the sphere $\varphi(e_0 \times S^k) \subset M$ will bound the disk $e_0 \times \mathbb{D}^{k+1}$ in $M(S, \varphi)$. Note that $e_0 \times S^k$ can be regarded as the graph of a section of the trivial bundle $\mathbb{D}^{m-k} \times S^k \rightarrow S^k$.

To see that $M(S, \varphi)$ is indeed a smooth manifold we observe that

$$U \setminus S \cong (\mathring{\mathbb{D}}^{m-k} \setminus 0) \times S^k.$$

Using spherical coordinates we obtain diffeomorphisms

$$\begin{aligned} (\mathring{\mathbb{D}}^{m-k} \setminus 0) \times S^k &\cong (0, 1) \times S^{m-k-1} \times S^k, \\ S^{m-k-1} \times (0, 1) \times S^k &\cong S^{m-k-1} \times (\mathbb{D}^{k+1} \setminus 0). \end{aligned}$$

Now attach $(S^{m-k-1} \times \mathbb{D}^{k+1})$ to U along $U \setminus S$ using the obvious diffeomorphism

$$(0, 1) \times S^{m-k-1} \times S^k \rightarrow S^{m-k-1} \times (0, 1) \times S^k.$$

The diffeomorphism type of $M(S, \varphi)$ depends on the isotopy class of the embedding $S \hookrightarrow M$ and on the regular homotopy class of the framing φ . We say that $M(S, \varphi)$ is obtained from M by a surgery of type (S, φ) .

Example 2.1 (Zero dimensional surgery). Suppose M is a smooth m -dimensional manifold consisting of two connected components M_{\pm} . A 0-dimensional sphere S^0 consists of two points p_{\pm} . Fix an embedding $S^0 \hookrightarrow M$ such that $p_{\pm} \in M_{\pm}$. Fix open neighborhoods U_{\pm} of $p_{\pm} \in M_{\pm}$ diffeomorphic to $\mathring{\mathbb{D}}^m$ and set $U = U_- \cup U_+$. Then

$$\partial(M \setminus U) \cong \partial U_- \cup \partial U_+ \cong S^0 \times S^{m-1}.$$

If we now glue $\mathbb{D}^1 \times S^{m-1} = [-1, 1] \times S^{m-1}$ such that $\{\pm 1\} \times S^{m-1}$ is identified with ∂U_{\pm} , we deduce that the surgery of $M_- \cup M_+$ along the zero sphere $\{p_{\pm}\}$ is diffeomorphic to the connected sum $M_- \# M_+$. Equivalently, we identify $(-1, 0) \times S^{m-1} \subset \mathbb{D}^1 \times S^{m-1}$ with the punctured neighborhood $U_- \setminus \{p_-\}$ (so that for $s \in (-1, 0)$ the parameter $-s$ is the radial distance in U_-) and then identify $(0, 1) \times S^{m-1}$ with the punctured neighborhood $U_+ \setminus \{p_+\}$ (so that $s \in (0, 1)$ represents the radial distance). \square

Example 2.2 (Codimension two surgery). Suppose M^m is a compact, oriented smooth manifold $m \geq 3$ and $i : S^{m-2} \hookrightarrow M$ is an embedding of a $(m - 2)$ -sphere with trivializable normal bundle. Set $S = i(S^{m-2})$. The natural orientation on S^{m-2} (as boundary of the unit disk in \mathbb{R}^{m-1}) induces an orientation on S . We have a short exact sequence

$$0 \rightarrow TS \rightarrow TM|_S \rightarrow T_S M \rightarrow 0$$

of vector bundles over S .

The orientation on S together with the orientation on M induce via the above sequence an orientation on the normal bundle $T_S M$. Fix a metric on this bundle and denote by $\mathbb{D}_S M$ the associated unit disk bundle. Since the normal bundle has rank 2, the orientation on $T_S M$ makes it possible to speak of *counterclockwise* rotations in each fiber. A trivialization is then uniquely determined by a choice of section

$$\mathbf{e} : S \rightarrow \partial\mathbb{D}_S M.$$

Given such a section \mathbf{e} , we obtain a positively oriented orthonormal frame (\mathbf{e}, \mathbf{f}) of $T_S M$, where \mathbf{f} is obtained from \mathbf{e} by a $\pi/2$ counterclockwise rotation. In particular, we obtain an embedding

$$\varphi_{\mathbf{e}} : \mathbb{D}^2 \times S^{m-2} \cong \mathbb{D}_S M \hookrightarrow M.$$

Once we fix such a section $\mathbf{e}_0 : S \rightarrow \partial\mathbb{D}_S M$ we obtain a trivialization

$$\partial\mathbb{D}_S M \cong S^1 \times S,$$

and then any other framing is described by a smooth map $S^{m-2} \rightarrow S^1$. We see that the homotopy classes of framings are classified by $\pi_{m-2}(S^1)$. In particular, this shows that the choice of framing becomes relevant only when $m = 3$.

The surgery on the framed sphere (S, \mathbf{e}_0) has the effect of removing a tubular neighborhood $U \cong \varphi_{\mathbf{e}_0}(\mathbb{D}^2 \times S^{m-2})$ and replacing it with the manifold $\hat{U} = S^1 \times \mathbb{D}^{m-1}$, which has identical boundary.

The section \mathbf{e}_0 of $\partial\mathbb{D}_S \rightarrow S$ traces a submanifold $L_0 \subset \partial\mathbb{D}_S M$ diffeomorphic to S^{m-2} . Via the trivialization $\varphi_{\mathbf{e}_0}$ it traces a sphere $\varphi_{\mathbf{e}_0}(L_0) \subset \partial U$ called the *attaching sphere* of the surgery. After the surgery, this attaching sphere will bound the disk $\{1\} \times \mathbb{D}^{m-1} \subset \hat{U}$. \square

Example 2.3 (Surgery on knots in S^3). Suppose $M = S^3$ and that K is a smooth embedding of a circle S^1 in S^3 . Such embeddings are commonly referred to as *knots*.

A classical result of Seifert (see [Rolf, 5.A]) states that any such knot bounds an orientable Riemann surface X smoothly embedded in S^3 . The interior-pointing unit normal along $\partial X = K$ defines a nowhere vanishing section of the normal bundle $T_K S^3$ and thus defines a framing of this bundle. This

is known as the *canonical framing*¹ of the knot. It defines a diffeomorphism between a tubular neighborhood U of the knot and the solid torus $\mathbb{D}^2 \times S^1$.

The canonical framing traces the curve

$$\ell = \ell_K = \{1\} \times S^1 \subset \partial\mathbb{D}^2 \times S^1.$$

The curve ℓ is called the *longitude* of the knot, while the boundary $\partial\mathbb{D}^2 \times \{1\}$ of a fiber of the normal disk bundle defines a curve called the *meridian* of the knot and denoted by $\mu = \mu_K$.

Any other framing of the normal bundle will trace a curve φ on $\partial U \cong \partial\mathbb{D}^2 \times S^1$ isotopic inside U to the axis $K = \{0\} \times S^1$ of the solid torus U . Thus in $H_1(\partial\mathbb{D}^2 \times S^1, \mathbb{Z})$ it has the form

$$[\varphi] = p[\mu] + [\ell],$$

where the integer p is the winding number of φ in the meridional plane \mathbb{D}^2 . The curve φ is called the *attaching curve* of the surgery.

The integer p completely determines the isotopy class of φ . Thus every surgery on a knot in S^3 is uniquely determined by an integer p called the *coefficient of the surgery*, and the surgery with this framing coefficient will be called *p-surgery*. We denote by $S^3(K, p)$ the result of a p -surgery on the knot K .

The attaching curve of the surgery φ is a *parallel* of the knot K . By definition, a parallel of K is a knot K' located in a thin tubular neighborhood of K with the property that the radial projection onto K defines a homeomorphism $K' \rightarrow K$. Conversely, every parallel K' of the knot K can be viewed as the attaching curve of a surgery. The surgery coefficient is then the *linking number* of K and K' , denoted by $\mathbf{lk}(K, K')$.

When we perform a p -surgery on K we remove the solid torus $U = \mathbb{D}^2 \times S^1$ and we replace it with a new solid torus $\hat{U} = S^1 \times \mathbb{D}^2$, so that in the new manifold the attaching curve $K_p = \ell + p\mu$ will bound the disk $\{1\} \times \mathbb{D}^2 \subset \hat{U}$.

Let us look at a very simple yet fundamental example. Think of S^3 as the round sphere

$$\{(z_0, z_1) \in \mathbb{C}^2; |z_0|^2 + |z_1|^2 = 2\}.$$

Consider the closed subsets $U_i = \{(z_0, z_1) \in S^3; |z_i| \leq 1\}$, $i = 0, 1$. Observe that U_0 is a solid torus via the diffeomorphism

$$U_0 \ni (z_0, z_1) \mapsto (z_0, \frac{z_1}{|z_1|}) \in \mathbb{D}^2 \times S^1.$$

Denote by K_i the knot in S^3 defined by $z_i = 0$. For example, K_0 admits the parametrization

$$[0, 1] \ni t \mapsto (0, \sqrt{2}e^{2\pi it}) \in S^3.$$

The knots K_0, K_1 are disjoint and form the *Hopf link*. Both are unknotted (see Figure 2.1).

¹ Its homotopy class is indeed independent of the choice of the Seifert surface X .

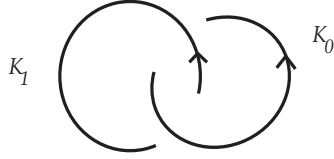

Fig. 2.1. The Hopf link.

For example, K_0 bounds the embedded 2-disk

$$X_0 := \{\zeta \in \mathbb{C}; |\zeta| \leq 2\} \hookrightarrow \{(z_0, z_1) = (\sqrt{2 - |\zeta|^2}, \zeta), \in S^3\}.$$

Observe that U_0 is a tubular neighborhood of K_0 , and the above isomorphism identifies it with the trivial 2-disk bundle, thus defining a framing of K_0 . This framing is the canonical framing of U_0 . The longitude of this framing is the curve

$$\ell_0 = \partial U_0 \cap X_0 = \{(1, e^{2\pi it}); t \in [0, 1]\}.$$

The meridian of K_0 is the curve $z_0 = e^{2\pi it}, z_1 = 1, t \in [0, 1]$. Via the diffeomorphism

$$U_1 \rightarrow \mathbb{D}^2 \times S^1, \quad U_1 \ni (z_0, z_1) \mapsto \left(z_1, \frac{1}{|z_0|} z_0\right) \in \mathbb{D}^2 \times S^1,$$

this curve can be identified with the *meridian* μ_1 of K_1 .

Set $M_p := S^3(K, p)$. The manifold M_p is obtained by removing U_0 from S^3 and gluing back a solid torus $\hat{U}_0 = S^1 \times \mathbb{D}^2$ to the complement of U_0 , which is the solid torus U_1 , so that

$$\partial \hat{U}_0 \supset \hat{\mu}_0 = \{1\} \times \partial \mathbb{D}^2 \mapsto p[\mu_0] + [\ell_0] = p[\mu_0] + [\mu_1].$$

For $p = 0$ we see that the disk $\{1\} \times \partial \mathbb{D}^2 \in S^1 \times \mathbb{D}^2 = \hat{U}_0$ bounds a disk in \hat{U}_0 and a meridional disk in U_1 . The result of zero surgery on the unknot will then be $S^1 \times S^2$.

If $p \neq 0$, we can compute the fundamental group of M_p using the van Kampen theorem. Denote by T the solid torus $\partial \hat{U}_0$, by j_0 the inclusion induced morphism $\pi_1(T) \rightarrow \pi_1(\hat{U}_0)$, and by j_1 the inclusion induced morphism $\pi_1(T) \rightarrow \pi_1(U_1)$. As generators of $\pi_1(T)$ we can choose μ_0 and the attaching curve of the surgery $\varphi = \mu_0^p \ell_0$ because the intersection number of these two curves is ± 1 . As generator of $\pi_1(U_1)$ we can choose $\ell_1 = \mu_0$ because the longitude of K_1 is the meridian of K_0 . As generator of $\pi_1(\hat{U}_0)$ we can choose $j_0(\mu_0)$ because j_0 is surjective and $\varphi \in \ker j_0$. Thus $\pi_1(M_p)$ is generated by μ_0, φ with the relation

$$1 = j_0(\hat{\mu}_0) = j_p(\hat{\mu}_0) = \mu_0^p \ell_0, \quad \ell_0 = j_0(\ell_0) = j_p(\ell_0), \quad j_p(\mu_0) = j_0(\mu_0).$$

Hence $\pi_1(M_p) \cong \mathbb{Z}/p$. In fact, M_p is a lens space. More precisely, we have an *orientation preserving* diffeomorphism

$$S^3(K_0, \pm|p|) \cong L(|p|, |p| \pm 1). \quad \square$$

Example 2.4 (Surgery on the trefoil knot). Suppose K is a knot in S^3 . Choose a closed tubular neighborhood U of K . The canonical framing of K defines a diffeomorphism $U = \mathbb{D}^2 \times S^1$. Denote by E_K the exterior

$$E_K = S^3 \setminus \text{int}(U).$$

Let $T = \partial E_K = \partial U$, and denote by $i_* : \pi_1(T) \rightarrow \pi_1(E_K)$ the inclusion induced morphism. Let $K' \subset T$ be a *parallel* of K , i.e., a simple closed curve that intersects a meridian $\mu = \partial \mathbb{D}^2 \times \{pt\}$ of the knot exactly once.

The parallel K' determines a surgery on the knot K with surgery coefficient $p = \mathbf{lk}(K, K')$. To compute the fundamental group of $S^3(K, p)$ we use as before the van Kampen theorem.

Suppose $\pi_1(E_K)$ has a presentation with the set of generators \mathcal{G}_K and relations \mathcal{R}_K . Let $\hat{U} = S^1 \times \mathbb{D}^2$ and denote by j the natural map

$$\partial U = \partial \mathbb{D}^1 \times S^1 \rightarrow S^1 \times \mathbb{D}^2 = \hat{U}.$$

Then $\pi_1(\hat{U})$ is generated by $\hat{\ell} = j_*(\mu)$ and we deduce that $S^3(K, p)$ has a presentation with generators $\mathcal{G} \cup \{\hat{\ell}\}$ and relation

$$i_*(K') = 1, \quad \hat{\ell} = j_*(\mu).$$

Equivalently, a presentation of $S^3(K, p)$ is obtained from a presentation of $\pi_1(E_K)$ by adding a single relation

$$i_*(K') = 1.$$

The fundamental group of the complement of the knot is called the *group of the knot*, and we will denote it by G_K . Let us explain how to compute a presentation of G_K and the morphism i_* .

Observe first that $\pi_1(T)$ is a free Abelian group of rank 2. As basis of $\pi_1(T)$ we can choose any pair (μ, γ) , where γ is a parallel of K situated on T . Then we can write

$$K' = a\mu + b\gamma.$$

If w denotes the linking number of γ and K , and ℓ denotes the longitude of K , then we can write $\gamma = w\mu + \ell$,

$$K' = p\mu + \ell = a\mu + b(w\mu + \ell) \implies b = 1, \quad a = p - w, \quad K' = (p - w)\mu + \gamma.$$

Thus i_* is completely understood if we know $i_*(\mu)$ and $i_*(\gamma)$ for some parallel γ of K .

The group of the knot K can be given an explicit presentation in terms of the *knot diagram*. This algorithmic presentation is known as the *Wirtinger*

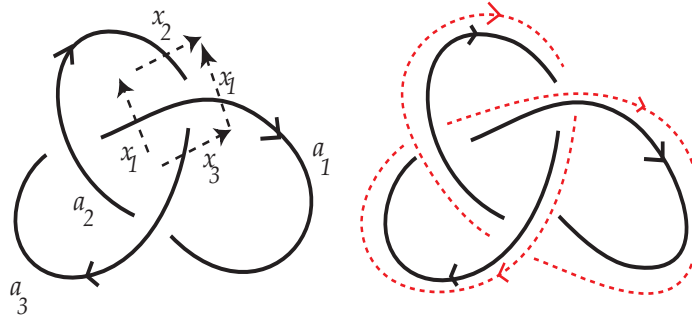

Fig. 2.2. The (left-handed) trefoil knot and its blackboard parallel.

presentation. We describe it the special case of the (left-handed) trefoil knot depicted in Figure 2.2 and we refer to [Rolf, III.A] for proofs.

The Wirtinger algorithm goes as follows.

- Choose an orientation of the knot and a basepoint $*$ situated off the plane of the diagram. Think of the basepoint as the location of the eyes of the reader.
- The diagram of the knot consists of several disjoint arcs. Label them by a_1, a_2, \dots, a_ν in increasing cyclic order given by the above chosen orientation of the knot. In the case of the trefoil knot we have three arcs, a_1, a_2, a_3 .
- To each arc a_k there corresponds a generator x_k represented by a loop starting at $*$ and winding around a_k once in the positive direction, where the positive direction is determined by the right-hand rule: if you point your right-hand thumb in the direction of a_k , then the rest of your palm should be wrapping around a_k in the direction of x_k (see Figure 2.3).
- For each crossing of the knot diagram we have a relation. The crossings are of two types, positive (+) (or right-handed) and negative (−) (or left-handed) (see Figure 2.3). Label by i the crossing where the arc a_i begins and the arc a_{i-1} ends. Denote by $a_{k(i)}$ the arc going over the i th crossing and set

$$\epsilon(i) = \pm 1 \text{ if } i \text{ is a } \pm\text{-crossing.}$$

Then the relation introduced by the i th crossing is

$$x_i = x_{k(i)}^{-\epsilon(i)} x_{i-1} x_{k(i)}^{\epsilon(i)}.$$

The knot diagram defines a parallel of K called the *blackboard parallel* and denoted by K_{bb} . It is obtained by tracing a contour parallel and very close to the diagram of K and situated to the left of K with respect to the chosen orientation. In Figure 2.2 the blackboard parallel of the trefoil knot is depicted with a thin line.

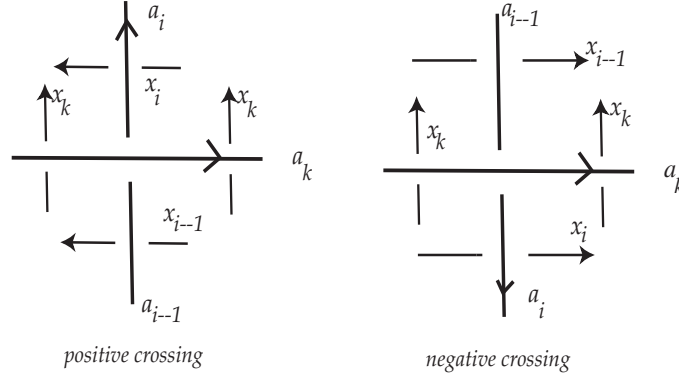

Fig. 2.3. The Wirtinger relations.

The linking number of K and K_{bb} is called the *writhe* of the knot diagram and it is denoted by $w(K)$. It is not an invariant of the knot. It is equal to the signed number of crossings of the diagram, i.e., the difference between the number of positive crossings and the number of negative crossings. One can show that

$$i_*(K_{bb}) = \prod_{i=1}^{\nu} x_{k(i)}^{\epsilon(i)}, \quad i_*(\mu) = x_{\nu}. \quad (2.1)$$

Set $G = G_K$, where K is the (left-handed) trefoil knot. In this case all the crossings in the diagram depicted in Figure 2.2 are negative and we have $w(K) = -3$. The group G has three generators x_1, x_2, x_3 , and since all the crossings are negative we conclude that $\epsilon(i) = -1, \forall i = 1, 2, 3$, so that we have three relations

$$x_1 = x_2 x_3 x_2^{-1}, \quad x_2 = x_3 x_1 x_3^{-1}, \quad x_3 = x_1 x_2 x_1^{-1}, \quad (2.2)$$

$$k(1) = 2, \quad k(2) = 3, \quad k(3) = 1. \quad (2.3)$$

From the equalities (2.3) we deduce

$$c = i_*(K_{bb}) = x_2^{-1} x_3^{-1} x_1^{-1}, \quad i_*(\mu) = x_3. \quad (2.4)$$

For $x \in G$ we denote by $T_x : G \rightarrow G$ the conjugation $g \mapsto xgx^{-1}$. We deduce

$$x_i = T_{x_{k(i)}} x_{i-1}, \quad \forall i = 1, 2, 3 \implies x_3 = T_{x_{k(1)}^{-1} x_{k(2)}^{-1} x_{k(3)}^{-1}} x_3 = T_c x_3,$$

i.e., x_3 commutes with $c = x_2^{-1} x_3^{-1} x_1^{-1}$. Set for simplicity

$$a = x_1, \quad b = x_2, \quad x_3 = T_a b = aba^{-1}.$$

We deduce from (2.2) that G has the presentation

$$G = \langle a, b \mid aba = bab \rangle.$$

Consider the group

$$H = \langle x, y \mid x^3 = y^2 \rangle.$$

We have a map

$$H \rightarrow G, \quad x \mapsto ab, \quad y \mapsto aba.$$

It is easily seen to be a morphism with inverse $a = x^{-1}y$, $b = a^{-1}x = y^{-1}x^2$ so that $G \cong H$.

If we perform -1 surgery on the (left handed) trefoil knot, then the attaching curve of the surgery is isotopic to

$$K' = -1 - w\mu + K_{bb}, \quad w = \text{lk}(K_{bb}, \ell) = -3,$$

and we conclude

$$i_*(K_{bb}) = c = x_2^{-1}x_3^{-1}x_1^{-1} = b^{-1}ab^{-1}a^{-1}a = b^{-1}ab^{-1}, \quad i_*(\mu) = aba^{-1}.$$

The fundamental group $\pi_1(S^3(K, -1))$ is obtained from G by introducing a new relation

$$i_*(\mu)^{-1-w} = c^{-1} \stackrel{w=-3}{\iff} ab^2a^{-1} = ba^{-1}b.$$

Hence the fundamental group of $S^3(K, -1)$ has the presentation

$$\langle a, b \mid aba = bab, ab^2a^{-1} = ba^{-1}b \rangle \iff \langle a, b \mid aba = bab, a^2b^2 = aba^{-1}ba \rangle.$$

Observe that its abelianization is trivial. However, this group is nontrivial. It has order 120 and it can be given the equivalent presentation

$$\langle x, y \mid x^3 = y^5 = (xy)^2 \rangle.$$

It is isomorphic to the binary icosahedral group I^* . This is the finite subgroup of $SU(2)$ that projects onto the subgroup $I \subset SO(3)$ of isometries of a regular icosahedron via the $2 : 1$ map $SU(2) \rightarrow SO(3)$.

The manifold $S^3(K, -1)$ is called the *Poincaré sphere*, and it is traditionally denoted by $\Sigma(2, 3, 5)$ because it is diffeomorphic to

$$\{z = (z_0, z_1, z_2) \in \mathbb{C}^3; \quad z_0^2 + z_1^3 + z_2^5 = 0, \quad |z| = \varepsilon\}.$$

It is a \mathbb{Z} -homology sphere, meaning that its homology is isomorphic to the \mathbb{Z} -homology of S^3 . □

Suppose that X is an m -dimensional smooth manifold with boundary. We want to describe what it means to attach a k -handle to X . This operation will produce a new smooth manifold with boundary.

A k -handle of dimension m (or a handle of index k) is the manifold with corners

$$\mathbf{H}_{k,m} := \mathbb{D}^k \times \mathbb{D}^{m-k}.$$

The disk $\mathbb{D}^k \times \{0\} \subset \mathbf{H}_{k,m}$ is called the *core*, while the disk $\{0\} \times \mathbb{D}^{m-k} \subset \mathbf{H}_{k,m}$ is called the *cocore*. The boundary of the handle decomposes as

$$\partial \mathbf{H}_{k,m} = \partial_- \mathbf{H}_{k,m} \cup \partial_+ \mathbf{H}_{k,m},$$

where

$$\partial_- \mathbf{H}_{k,m} := \partial \mathbb{D}^k \times \mathbb{D}^{m-k}, \quad \partial_+ \mathbf{H}_{k,m} := \mathbb{D}^k \times \partial \mathbb{D}^{k-m}.$$

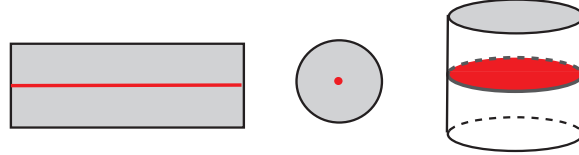

Fig. 2.4. A 1-handle of dimension 2, a 0-handle of dimension 2 and a 2-handle of dimension 3. The mid section disks are the cores of these handles.

The operation of attaching a k -handle (of dimension m) requires several additional data.

- A $(k - 1)$ -dimensional sphere $\Sigma \hookrightarrow \partial X$ embedded in ∂X with *trivializable* normal bundle $T_\Sigma \partial X$. This normal bundle has rank $m - k = \dim \partial X - \dim \Sigma$.
- A framing φ of the normal bundle $T_\Sigma \partial X$.

The framing defines a diffeomorphism from $\mathbb{D}^{m-k} \times S^{k-1}$ to a tubular neighborhood N of Σ in ∂X . Using this identification we detect inside N a copy of $\partial_- \mathbf{H}_{k,m} = \Sigma \times \mathbb{D}^{m-k}$. Now attach $\mathbf{H}_{k,m}$ to ∂X by identifying $\partial_- \mathbf{H}_{k,m}$ with its copy inside N and denote the resulting manifold by $X^+ = X(\Sigma, \varphi)$.

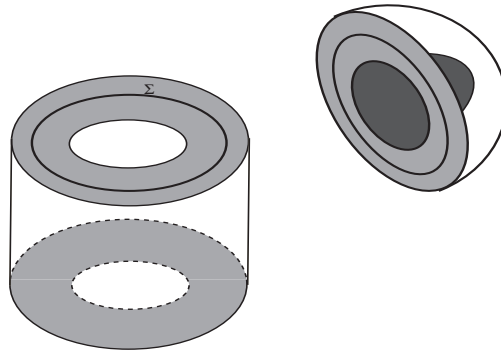

Fig. 2.5. Attaching a 2-handle of dimension 3.

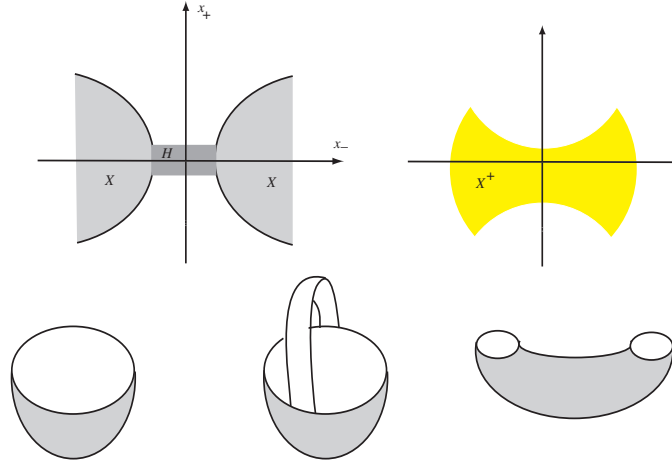

Fig. 2.6. Attaching a 1-handle of dimension 2 and smoothing the corners.

The manifold X^+ has corners, but they can be smoothed out (see Figure 2.6). The smoothing procedure is local, so it suffices to understand it in the special case

$$X \cong (-\infty, 0] \times \partial\mathbb{D}^k \times \mathbb{R}^{m-k}, \quad \partial X = \{0\} \times \partial\mathbb{D}^k \times \mathbb{R}^{m-k} (\cong N).$$

Consider the decomposition

$$\mathbb{R}^m = \mathbb{R}^k \times \mathbb{R}^{m-k}, \quad \mathbb{R}^m \ni x = (x_-, x_+) \in \mathbb{R}^k \times \mathbb{R}^{m-k}.$$

We have a homeomorphism

$$(-\infty, 0] \times \partial\mathbb{D}^k \times \mathbb{R}^{m-k} \longrightarrow \{x \in \mathbb{R}^m; |x_+|^2 - |x_-|^2 \leq -1\},$$

defined by

$$(-\infty, 0] \times \partial\mathbb{D}^k \times \mathbb{R}^{m-k} \ni (t, \theta, x_+) \mapsto ((e^{-2t} + |x_+|^2)^{1/2} \cdot \theta, x_+) \in \mathbb{R}^k \times \mathbb{R}^{m-k}.$$

The manifold X^+ obtained after the surgery is homeomorphic to

$$\{x \in \mathbb{R}^m; |x_+|^2 - |x_-|^2 \leq 1\},$$

which is a *smooth* manifold with boundary.

This homeomorphism is visible in Figure 2.6, but a formal proof can be read from Figure 2.7.

Let us explain Figure 2.7. We set $r_{\pm} = |x_{\pm}|$ and observe that

$$X \cong \{r_- \geq 1\}, \quad \mathbf{H}_{k,m} = \{r_-, r_+ \leq 1\}.$$

After we attach the handle we obtain

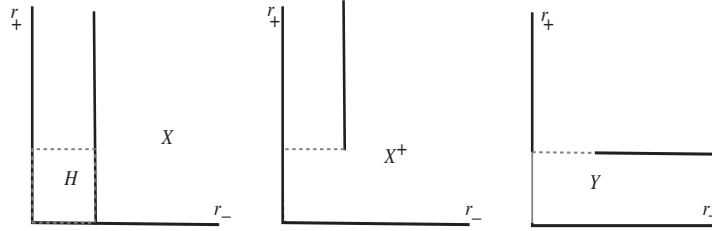

Fig. 2.7. *Smoothing corners.*

$$X_+ = \{r_- \geq 1\} \cup \{r_- \leq 1, r_+ \leq 1\}.$$

Now fix a homeomorphism

$$X_+ \rightarrow Y = \{r_+ \leq 1\},$$

which is the identity in a neighborhood of the region $\{r_- \cdot r_+ = 0\}$. Clearly Y is homeomorphic to the region $r_+^2 - r_-^2 \leq 1$ via the homeomorphism

$$Y \ni (x_-, x_+) \mapsto (x_-, (1 + r_-^2)^{1/2} x_+).$$

Let us analyze the difference between the topologies of ∂X^+ and ∂X .

Observe that we have a decomposition

$$\partial X^+ = (\partial X \setminus \partial_- \mathbf{H}_{k,m}) \cup_{\varphi} \partial_+ \mathbf{H}_{k,m}.$$

Above, $(\partial X \setminus \partial_- \mathbf{H}_{k,m})$ is a manifold with boundary diffeomorphic to $\partial \mathbb{D}^{m-k} \times S^{k-1}$ which is identified with the boundary of $\partial_+ \mathbf{H}_{k,m} = \mathbb{D}^k \times \partial \mathbb{D}^{m-k}$ via the chosen framing φ . In other words, ∂X^+ is obtained from ∂X via the surgery given by the data (S, φ) .

In general, if M_1 is obtained from M_0 by a surgery of type (S, φ) , then M_1 is cobordant to M_0 . Indeed, consider the manifold

$$X = [0, 1] \times M_0.$$

We obtain an embedding $S \hookrightarrow \{1\} \times M_0 \hookrightarrow \partial X$ and a framing φ of its normal bundle. Then

$$\partial X(S, \varphi) = M_0(S, \varphi) \sqcup M_0.$$

The above cobordism $X(S, \varphi)$ is called the *trace* of the surgery.

2.2 The Topology of Sublevel Sets

Suppose M is a smooth connected m -dimensional manifold and $f : M \rightarrow \mathbb{R}$ is an *exhaustive* Morse function, i.e., the sublevel set

$$M^c = \{x \in M; f(x) \leq c\}$$

is compact for every $c \in \mathbb{R}$. We fix a smooth vector field X on M that is *gradient-like* with respect to f . This means that

$$X \cdot f > 0 \text{ on } M \setminus \mathbf{Cr}_f,$$

and for every critical point p of f there exist coordinates (x^i) adapted to p such that

$$X = -2 \sum_{i=1}^{\lambda} x^i \partial_{x^i} + 2 \sum_{j>\lambda} x^j \partial_{x^j}, \quad \lambda = \lambda(f, p).$$

In these coordinates near p the flow Γ_t generated by $-X$ is described by

$$\Gamma_t(x) = e^{2t}x_- + e^{-2t}x_+,$$

where $x = x_- + x_+$,

$$x_- := (x^1, \dots, x^\lambda, 0, \dots, 0), \quad x_+ := (0, \dots, 0, x^{\lambda+1}, \dots, x^m).$$

To see that there exist such vector fields choose a Riemannian metric g adapted to f , i.e., a metric with the property that for every critical point p of f there exist coordinates (x^i) adapted to p such that near p we have

$$g = \sum_{i=1}^m (dx^i)^2, \quad f = f(p) + \sum_{j=1}^{\lambda} (x^j)^2 - \sum_{k>\lambda} (x^k)^2.$$

We denote by $\nabla f = \nabla^g f \in \text{Vect}(M)$ the *gradient* of f with respect to the metric g , i.e., the vector field g -dual to the differential df . More precisely, ∇f is defined by the equality

$$g(\nabla f, X) = df(X) = X \cdot f, \quad \forall X \in \text{Vect}(M).$$

In local coordinates (x^i) , if

$$df = \sum_i \frac{\partial f}{\partial x^i} dx^i, \quad g = \sum_{i,j} g_{ij} dx^i dx^j,$$

then

$$\nabla f = \sum_j g^{ij} \partial_{x^j} f,$$

where $(g^{ij})_{1 \leq i, j \leq m}$ denotes the matrix inverse to $(g_{ij})_{1 \leq i, j \leq m}$. In particular, near a critical point p of index λ the gradient of f in the above coordinates is given by

$$\nabla f = -2 \sum_{i=1}^{\lambda} x^i \partial_{x^i} + 2 \sum_{j>\lambda} x^j \partial_{x^j}.$$

This shows that $X = \nabla f$ is a gradient-like vector field.

Remark 2.5. As explained in [Sm, Theorem B], any gradient-like vector field can be obtained by the method described above. \square

Notation. In the sequel, when referring to $f^{-1}((a, b))$, we will use the more suggestive notation $\{a < f < b\}$. The same goes for $\{a \leq f < b\}$, etc. \square

Theorem 2.6. *Suppose that the interval $[a, b] \in \mathbb{R}$ contains no critical values of f . Then the sublevel sets M^a and M^b are diffeomorphic. Furthermore, M^a is a deformation retract of M^b , so that the inclusion $M^a \hookrightarrow M^b$ is a homotopy equivalence.*

Proof. Since there are no critical values of f in $[a, b]$ and the sublevel sets M^c are compact, we deduce that there exists $\varepsilon > 0$ such that

$$\{a - \varepsilon < f < b + \varepsilon\} \subset M \setminus \mathbf{Cr}_f.$$

Fix a gradient-like vector field Y and construct a smooth function

$$\rho : M \rightarrow [0, \infty)$$

such that

$$\rho(x) = \begin{cases} |Yf|^{-1} & a \leq f(x) \leq b, \\ 0 & f(x) \notin (a - \varepsilon, b + \varepsilon). \end{cases}$$

We can now construct the vector field $X := -\rho Y$ on M , and we denote by

$$\Phi : \mathbb{R} \times M \rightarrow M, \quad (t, x) \mapsto \Phi_t(x)$$

the flow generated by X . If $u(t)$ is an integral curve of X , i.e., $u(t)$ satisfies the differential equation

$$\dot{u} = X(u),$$

then differentiating f along $u(t)$, we deduce that in the region $\{a \leq f \leq b\}$ we have the equality

$$\frac{df}{dt} = Xf = -\frac{1}{Yf} Yf = -1.$$

In other words, in the region $\{a \leq f \leq b\}$ the function f decreases at a rate of one unit per second. This implies

$$\Phi_{b-a}(M^b) = M^a, \quad \Phi_{a-b}(M^a) = M^b,$$

so that Φ_{b-a} establishes a diffeomorphism between M^b and M^a .

To show that M^a is a deformation retract of M^b , we consider

$$H : [0, 1] \times M^b \rightarrow M^b, \quad H(t, x) = \Phi_{t \cdot (f(x) - a)^+}(x),$$

where for every real number r we set $r^+ := \max(r, 0)$. Observe that if $f(x) \leq a$, then

$$H(t, x) = x, \quad \forall t \in [0, 1],$$

while for every $x \in M^b$ we have

$$H(1, x) = \Phi_{(f(x)-a)^+}(x) \in M^a.$$

This proves that M^a is a deformation retract of M^b . □

Theorem 2.7 (Fundamental structural theorem). *Suppose c is a critical value of f containing a single critical point p of Morse index λ . Then for every $\varepsilon > 0$ sufficiently small the sublevel set $\{f \leq c + \varepsilon\}$ is diffeomorphic to $\{f \leq c - \varepsilon\}$ with a λ -handle of dimension m attached. If $x = (x_-, x_+)$ are coordinates adapted to the critical point, then the core of the handle is given by*

$$e_\lambda(p) := \{x_+ = 0, |x_-|^2 \leq \varepsilon\}.$$

In particular, $\{f \leq c + \varepsilon\}$ is homotopic to $\{f \leq c - \varepsilon\}$ with the λ -cell e_λ attached.

Proof. We follow the elegant approach in [M3, Section I.3]. There exist $\varepsilon > 0$ and local coordinates (x^i) in an open neighborhood U of p with the following properties.

- The region $\{|f - c| \leq \varepsilon\}$ is compact and contains no critical point of f other than p .
- $x^i(p) = 0, \forall i$ and the image of U under the diffeomorphism

$$(x^1, \dots, x^m) : U \rightarrow \mathbb{R}^m$$

contains the closed disk

$$D = \left\{ \sum (x^i)^2 \leq 2\varepsilon \right\}.$$

•

$$f|_D = c - \sum_{i \leq \lambda} (x^i)^2 + \sum_{j > \lambda} (x^j)^2.$$

We set

$$x_- := (x^1, \dots, x^\lambda, 0, \dots, 0), \quad u_- := \sum_{i \leq \lambda} (x^i)^2,$$

$$x_+ := (0, \dots, 0, x^{\lambda+1}, \dots, x^m), \quad u_+ := \sum_{j > \lambda} (x^j)^2.$$

We have

$$f|_D = c - u_- + u_+.$$

We fix a smooth function $\mu : [0, \infty) \rightarrow \mathbb{R}$ with the following properties (see Figure 2.8).

$$\mu(0) > \varepsilon, \quad \mu(t) = 0, \quad \forall t \geq 2\varepsilon, \quad (2.5)$$

$$-1 < \mu'(t) \leq 0, \quad \forall t \geq 0. \quad (2.6)$$

Now let (see Figure 2.8)

$$h := \mu(0) > \varepsilon, \quad r := \min\{t; \mu(t) = 0\} \leq 2\varepsilon.$$

Define

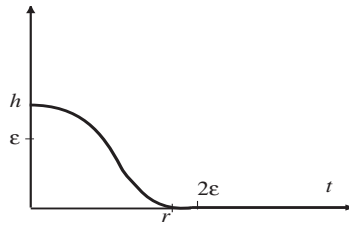

Fig. 2.8. The cutoff function μ .

$$F : M \rightarrow \mathbb{R}, \quad F = f - \mu(u_- + 2u_+),$$

so that along D we have

$$F|_U = c - u_- + u_+ - \mu(u_- + 2u_+),$$

while on $M \setminus D$ we have $F = f$.

Lemma 2.8. *The function F satisfies the following properties.*

(a) F is a Morse function,

$$\mathbf{Cr}_F = \mathbf{Cr}_f, \quad F(p) < c - \varepsilon, \quad \text{and} \quad F(q) = f(q), \quad \forall q \in \mathbf{Cr}_f \setminus \{p\}.$$

(b) $\{f \leq a\} \subset \{F \leq a\}$, $\forall a \in \mathbb{R}$, $\{F \leq c + \delta\} = \{f \leq c + \delta\}$, $\forall \delta \geq \varepsilon$.

Proof. (a) Clearly $\mathbf{Cr}_F \cap (M \setminus D) = \mathbf{Cr}_f \cap (M \setminus U)$. To show that $\mathbf{Cr}_F \cap D = \mathbf{Cr}_f \cap D$ we use the fact that along D we have

$$F = f - \mu(u_- + 2u_+), \quad dF = -(1 + \mu')du_- + (1 - 2\mu')du_+.$$

The condition (2.6) implies that $du_- = 0 = du_+$ at every critical point q of F in U , so that $x_-(q) = 0$, $x_+(q) = 0$, i.e., $q = p$. Clearly $F(p) = f(p) - \mu(0) < c - \varepsilon$. Clearly p is a nondegenerate critical point of F .

(b) Note first that

$$F \leq f \implies \{f \leq a\} \subset \{F \leq a\}, \quad \forall a \in \mathbb{R}.$$

Again we have

$$\{F \leq c + \delta\} \cap (M \setminus D) = \{f \leq c + \delta\} \cap (M \setminus D),$$

so we have to prove

$$\{F \leq c + \delta\} \cap D \subset \{f \leq c + \delta\} \cap D.$$

Suppose $q \in \{F \leq c + \delta\} \cap D$ and set $u_{\pm} = u_{\pm}(q)$. This means that

$$u_- + u_+ \leq 2\varepsilon, \quad u_+ \leq u_- + \delta + \mu(u_- + 2u_+).$$

Using the condition $-1 < \mu'$ we deduce

$$\mu(t) = \mu(t) - \mu(2\varepsilon) \leq 2\varepsilon - t \leq 2\delta - t, \quad \forall t \leq 2\varepsilon.$$

If $u_- + 2u_+ \leq 2\varepsilon$, we have

$$\begin{aligned} u_- + \delta + \mu(u_- + 2u_+) &\leq 3\delta - 2u_+ \Rightarrow u_+ \leq \delta \\ &\Rightarrow u_+ - u_- \leq \delta \Rightarrow f(q) \leq c + \delta. \end{aligned}$$

If $u_- + 2u_+ \geq 2\varepsilon$, then $f(q) = F(q) \leq c + \varepsilon$. \square

The above lemma implies that F is an exhaustive Morse function such that the interval $[c - \varepsilon, c + \varepsilon]$ consists only of regular values. We deduce from Theorem 2.6 that $\{F \leq c + \varepsilon\}$ is diffeomorphic to $\{F \leq c - \varepsilon\}$. Since

$$\{F \leq c + \varepsilon\} = \{f \leq c + \varepsilon\},$$

it suffices to show that $\{F \leq c - \varepsilon\}$ is diffeomorphic to $\{f \leq c - \varepsilon\}$ with a λ -handle attached.

Denote by H the closure of

$$\{F \leq c - \varepsilon\} \setminus \{f \leq c - \varepsilon\} = \{F \leq c - \varepsilon\} \cap \{f > c - \varepsilon\}.$$

Observe that

$$H = \{F \leq c - \varepsilon\} \cap \{f \geq c - \varepsilon\} \subset D.$$

The region H is described by the system of inequalities

$$\begin{cases} u_- + u_+ \leq 2\varepsilon, \\ f = -u_- + u_+ \geq -\varepsilon, & \mu = \mu(u_- + 2u_+). \\ F = -u_- + u_+ - \mu \leq -\varepsilon, \end{cases}$$

Its boundary decomposes as $\partial H = \partial_- H \cup \partial_+ H$, where

$$\partial_- H = \begin{cases} u_- + u_+ \leq 2\varepsilon & f = -u_- + u_+ = -\varepsilon, \\ F = -u_- + u_+ - \mu \leq -\varepsilon, \end{cases}$$

and

$$\partial_+ H = \begin{cases} u_- + u_+ \leq 2\varepsilon, \\ f = -u_- + u_+ \geq -\varepsilon, \\ F = -u_- + u_+ - \mu = -\varepsilon. \end{cases}$$

Let us analyze the region R in the Cartesian plane described by the system of inequalities

$$x, y \geq 0, \quad x + y \leq 2\varepsilon, \quad -x + y - \mu(x + 2y) \leq -\varepsilon, \quad -x + y \geq -\varepsilon.$$

The region

$$\{y - x \geq -\varepsilon, \quad x + y \leq 2\varepsilon, \quad x, y \geq 0\}$$

is the shaded polygonal area depicted in Figure 2.9. The two lines $y - x = -\varepsilon$

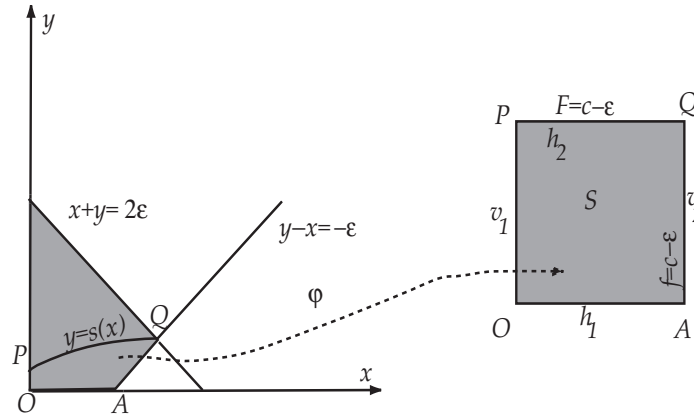

Fig. 2.9. A planar convex region.

and $x + y = 2\varepsilon$ intersect at the point $Q = (\frac{3\varepsilon}{2}, \frac{\varepsilon}{2})$. We want to investigate the equation

$$-x + y - \mu(x + 2y) + \varepsilon = 0.$$

Set

$$\eta_x(y) := -x + y - \mu(x + 2y) + \varepsilon.$$

Observe that since $\mu(x) > \mu(0) - x$, we have

$$\eta_x(0) = -x - \mu(x) + \varepsilon < -\mu(0) + \varepsilon < 0,$$

while

$$\lim_{y \rightarrow \infty} \eta_x(y) = \infty.$$

Since $y \mapsto \eta_x(y)$ is strictly increasing there exists a unique solution $y = s(x)$ of the equation $\eta_x(y) = 0$. Using the implicit function theorem we deduce that $s(x)$ depends smoothly on x and

$$\frac{ds}{dx} = \frac{1 + \mu'}{1 - 2\mu'} \in [0, 1].$$

The point Q lies on the graph of the function $y = s(x)$, $s(0) > 0$, and since $s'(x) \in [0, 1]$, we deduce that the slope-1 segment AQ lies below the graph of $s(x)$. We now see that the region R is described by the system of inequalities

$$x, y \geq 0, \quad y \leq s(x), \quad y - x \geq -\varepsilon.$$

Fix a homeomorphism φ from R to the standard square

$$S = \{ (t_-, t_+) \in \mathbb{R}^2; \quad 0 \leq t_{\pm} \leq 1 \}$$

such that the vertices O, A, P, Q are mapped to the vertices

$$(0, 0), \quad (1, 0), \quad (1, 1), \quad (0, 1)$$

(see Figure 2.9). Denote by h_i and v_j the horizontal and vertical edges of S (see Figure 2.9).

Observe that we have a natural projection

$$u : H \rightarrow \mathbb{R}^2, \quad H \ni q \mapsto (x, y) = (u_-(q), u_+(q)).$$

Its image is precisely the region R , and we denote by $t = (t_-, t_+)$ the composition $\varphi \circ u$. We now have a homeomorphism

$$H \mapsto \mathbf{H}_\lambda = \mathbb{D}^\lambda \times \mathbb{D}^{m-\lambda},$$

$$H \ni q \mapsto (t_-(q)\theta_-(q), t_+(q)\theta_+(q)) \in \mathbb{D}^\lambda \times \mathbb{D}^{m-\lambda},$$

where

$$\theta_{\pm}(q) = u_{\pm}^{-1/2}(q)x_{\pm}(q)$$

denote the angular coordinates in

$$\Sigma_- = \{ u_- = 1, \quad x_+ = 0 \} \cong S^{\lambda-1}$$

and

$$\Sigma_+ = \{ u_+ = 1, \quad x_- = 0 \} \cong S^{m-\lambda-1}.$$

Then $\partial_+ H$ corresponds to the part of H mapped by u onto h_2 , and $\partial_- H$ corresponds to the part of H mapped by u onto v_2 . The core is the part mapped onto the horizontal segment h_1 , while the co-core is the part of H mapped onto v_1 . This discussion shows that indeed $\{ F \leq c - \varepsilon \}$ is obtained from $\{ f \leq c - \varepsilon \}$ by attaching the λ -handle H . \square

Remark 2.9. Suppose that c is a critical value of the exhaustive Morse function $f : M \rightarrow \mathbb{R}$ and the level set $f^{-1}(c)$ contains critical points p_1, \dots, p_k with Morse indices $\lambda_1, \dots, \lambda_k$. Then the above argument shows that for $\varepsilon > 0$ sufficiently small the sublevel set $\{ f \leq c + \varepsilon \}$ is obtained from $\{ f \leq c - \varepsilon \}$ by attaching handles H_1, \dots, H_k of indices $\lambda_1, \dots, \lambda_k$. \square

Corollary 2.10. *Suppose M is a smooth manifold and $f : M \rightarrow \mathbb{R}$ is an exhaustive Morse function on M . Then M is homotopy equivalent to a CW-complex that has exactly one λ -cell for every critical point of f of index λ .* \square

Example 2.11 (Planar pentagons). Let us show how to use the fundamental structural theorem in a simple yet very illuminating example. We define a *regular planar pentagon* to be a closed polygonal line in the plane consisting of five straight line segments of equal length 1. We would like to understand the topology of the space of all possible regular planar pentagons.

Consider one such pentagon with vertices J_0, J_1, J_2, J_3, J_4 such that

$$\text{dist}(J_i, J_{i+1}) = 1.$$

There are a few trivial ways of generating new pentagons out of a given one. We can translate it, or we can rotate it about a fixed point in the plane. The new pentagons are not that interesting, and we will declare all pentagons obtained in this fashion from a given one to be equivalent. In other words, we are really interested in orbits of pentagons with respect to the obvious action of the affine isometry group of the plane.

There is an natural way of choosing a representative in such an orbit. We fix a cartesian coordinate system and we assume that the vertex J_0 is placed at the origin, while the vertex J_4 lies on the positive x -semiaxis, i.e., J_4 has coordinates $(1, 0)$.

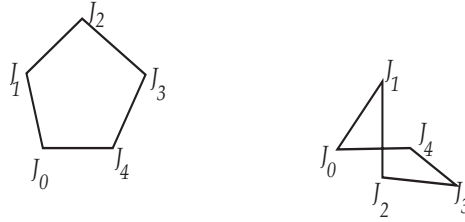

Fig. 2.10. *Planar pentagons.*

Note that we can regard such a pentagon as a robot arm with four segments such that the last vertex J_4 is fixed at the point $(0, 1)$. Now recall some of the notation in Example 1.5.

A possible position of such a robot arm is described by four complex numbers,

$$z_1, \dots, z_4, \quad |z_i| = 1, \quad \forall i = 1, 2, 3, 4.$$

Since all the segments of such a robot arm have length 1, the position of the vertex J_k is given by the complex number $z_1 + \dots + z_k$.

The space C of configurations of the robot arm constrained by the condition that J_4 can only slide along the positive x -semiaxis is a 3-dimensional manifold. On C we have a Morse function

$$h : C \rightarrow \mathbb{R}, \quad h(\mathbf{z}) = \mathbf{Re}(z_1 + z_2 + z_3 + z_4),$$

which measures the distance of the last joint to the origin. The space of pentagons can be identified with the level set $\{h = 1\}$.

Consider the function $f = -h : C \rightarrow \mathbb{R}$. The sublevel sets of f are compact. Moreover, the computations in Example 1.10 show that f has exactly five critical points, a local minimum

$$(1, 1, 1, 1),$$

and four critical configurations of index 1

$$(1, 1, 1, -1), \quad (1, 1, -1, 1), \quad (1, -1, 1, 1), \quad (-1, 1, 1, 1),$$

all situated on the level set $\{h = 2\} = \{f = -2\}$. The corresponding positions of the robot arm are depicted in Figure 2.11.

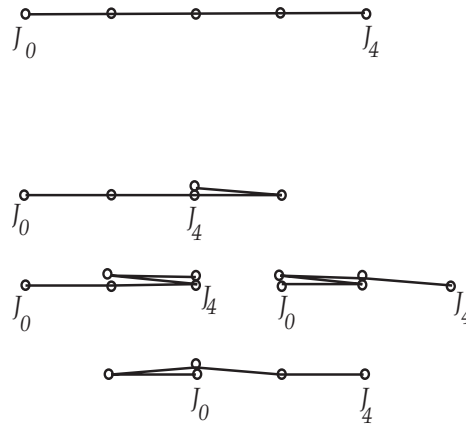

Fig. 2.11. Critical positions.

The level set $\{f = -1\}$ is not critical, and it is obtained from the sublevel set $\{f \leq -3\}$ by attaching four 1-handles.

The sublevel set $\{f \leq -3\}$ is a closed 3-dimensional ball, and thus the sublevel set $\{f \leq -1\}$ is a 3-ball with four 1-handles attached. Its boundary, $\{f = -1\}$, is therefore a Riemann surface of genus 4. We conclude that the space of orbits of regular planar pentagons is a Riemann surface of genus 4. For more general results on the topology of the space of planar polygons we refer to the very nice paper [KM]. \square

Remark 2.12. We can use the fundamental structural theorem to produce a new description of the trace of a surgery. We follow the presentation in [M4, Section 3].

Consider an orthogonal direct sum decomposition $\mathbb{R}^m = \mathbb{R}^\lambda \oplus \mathbb{R}^{m-\lambda}$. We denote by x the coordinates in \mathbb{R}^λ and by y the coordinates in $\mathbb{R}^{m-\lambda}$. Then identify

$$\mathbb{D}^\lambda = \{x \in \mathbb{R}^\lambda; |x| \leq 1\}, \quad \mathbb{D}^{m-\lambda} = \{y \in \mathbb{R}^{m-\lambda}; |y| \leq 1\},$$

$$\mathbf{H}_{\lambda,m} = \{(x,y) \in \mathbb{R}^m; |x|, |y| \leq 1\}.$$

Consider the regions (see Figure 2.12)

$$\hat{B}_\lambda := \{(x,y) \in \mathbb{R}^m; -1 \leq -|x|^2 + |y|^2 \leq 1, \quad 0 \leq |x| \cdot |y| < r\},$$

$$B_\lambda = \{(x,y) \in \hat{B}_\lambda; |x| \cdot |y| > 0\}.$$

The region B_λ has two boundary components (see Figure 2.12)

$$\partial_\pm B_\lambda = \{(x,y) \in B_\lambda; -|x|^2 + |y|^2 = \pm 1\}.$$

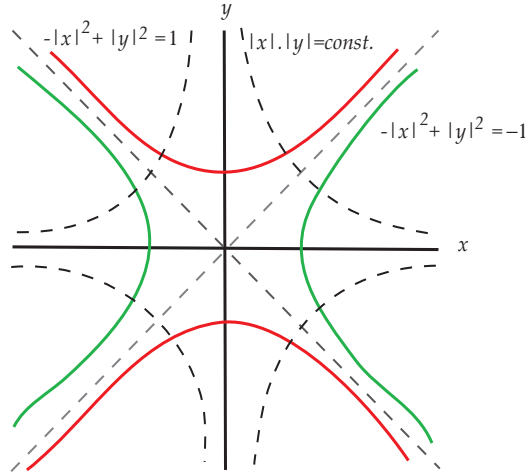

Fig. 2.12. A Morse theoretic picture of the trace of a surgery.

Consider the functions

$$f, h : \mathbb{R}^m \rightarrow \mathbb{R}, \quad f(x,y) = -|x|^2 + |y|^2, \quad h(x,y) = |x| \cdot |y|,$$

so that

$$B_\lambda = \{-1 \leq f \leq 1, \quad 0 < h < r\}, \quad \partial_\pm B_\lambda = \{f = \pm 1, \quad 0 < h < r\}.$$

Denote by U the gradient vector field of f . We have

$$U = -U_x + U_y, \quad U_x = 2 \sum_i x^i \partial_{x_i}, \quad U_y = 2 \sum_j y^j \partial_{y_j}.$$

The function h is differentiable in the region $h > 0$, and

$$\nabla h = \frac{|y|}{|x|}x + \frac{|x|}{|y|}y.$$

We deduce

$$U \cdot h = (\nabla h, U) = 0.$$

Define $V = \frac{1}{U \cdot f}U$. We have

$$V \cdot f = 1, \quad V \cdot h = 0.$$

Denote by Γ_t the flow generated by V . We have

$$\frac{d}{dt}f(\Gamma_t z) = 1, \quad \forall z \in \mathbb{R}^m \quad \text{and} \quad \frac{d}{dt}h(\Gamma_t z) = 0, \quad \forall z \in \mathbb{R}^m, \quad h(z) > 0.$$

Thus h is constant along the trajectories of V , and along such a trajectory f increases at a rate of one unit per second. We deduce that for any $z \in \partial_- B_\lambda$ we have

$$f(\Gamma_t z) = -1 + t, \quad h(\Gamma_t z) = h(z) \in (0, 1).$$

We obtain a diffeomorphism

$$\Psi : [-1, 1] \times \partial_- B_\lambda \rightarrow B_\lambda, \quad (t, z) \mapsto \Gamma_{t+1}(z).$$

Its inverse is

$$B_\lambda \ni w \mapsto (f(w), \Gamma_{-1-f(z)}w).$$

This shows that the pullback of $f : B_\lambda \rightarrow \mathbb{R}$ to $[-1, 1] \times \partial_- B_\lambda$ via Ψ coincides with the natural projection

$$[-1, 1] \times \partial_- B_\lambda \rightarrow [-1, 1].$$

Moreover, we have a diffeomorphism

$$\{1\} \times \partial_- B_\lambda \xrightarrow{\Psi} \partial_+ B_\lambda.$$

Now observe that we have a diffeomorphism

$$\begin{aligned} \Phi : (\mathbb{D}^{m-\lambda} \setminus \{0\}) \times S^{\lambda-1} &\rightarrow \partial_- B_\lambda, \\ (\mathbb{D}^{m-\lambda} \setminus \{0\}) \times S^{\lambda-1} \ni (u, v) &\mapsto (\cosh(|u|)v, \sinh(|u|)\theta_u) \in \mathbb{R}^\lambda \times \mathbb{R}^{m-\lambda}, \\ \theta_u &:= \frac{u}{|u|}. \end{aligned}$$

Suppose M is a smooth manifold of dimension $m-1$ and we have an embedding

$$\varphi : \mathbb{D}^{m-\lambda} \times S^{\lambda-1} \hookrightarrow M.$$

Consider the manifold $X = [-1, 1] \times M$ and set

$$X' = X \setminus \varphi\left([-1, 1] \times \{0\} \times S^{\lambda-1}\right).$$

Denote by W the manifold obtained from the disjoint union $X' \sqcup \hat{B}_\lambda$ by identifying $B_\lambda \subset \hat{B}_\lambda$ with an open subset of $[-1, 1] \times M$ via the gluing map $\gamma = \varphi \circ \Phi^{-1} \circ \Psi^{-1}$,

$$B_\lambda \xrightarrow{\Psi^{-1}} [-1, 1] \times \partial_- B_\lambda \xrightarrow{\Phi^{-1}} [-1, 1] \times (\mathring{\mathbb{D}}^{m-\lambda} \setminus \{0\}) \times S^{\lambda-1} \xrightarrow{\varphi} [-1, 1] \times M.$$

Via the above gluing, the restriction of f to B_λ is identified with the natural projection $\pi : X' \rightarrow [-1, 1]$, i.e.,

$$\gamma^*(f|_{B_\lambda}) = \pi|_{\gamma(B_\lambda)}$$

Gluing π and γ^*f we obtain a smooth function

$$F : W \rightarrow [-1, 1]$$

that has a unique critical point p with critical value $F(p) = 0$ and Morse index λ . Set

$$W^a = \{w \in W; F(w) \leq a\}.$$

We deduce from the fundamental structural theorem that $W^{1/2}$ is obtained from $W^{-1/2} \cong M$ by attaching a λ -handle with framing given by φ . The region $\{-\frac{1}{2} \leq F \leq \frac{1}{2}\}$ is therefore diffeomorphic to the trace of the surgery $M \rightarrow M(S^{\lambda-1}, \varphi)$. \square

2.3 Morse Inequalities

To formulate these important algebraic consequences of the topological facts established so far we need to introduce some terminology.

Denote by $\mathbb{Z}[[t, t^{-1}]]$ the ring of formal Laurent series with integral coefficients. More precisely,

$$\sum_{n \in \mathbb{Z}} a_n t^n \in \mathbb{Z}[[t, t^{-1}]] \iff a_n = 0 \quad \forall n \ll 0, \quad a_m \in \mathbb{Z}, \quad \forall m.$$

Suppose \mathbb{F} is a field. A graded \mathbb{F} -vector space

$$A_\bullet = \bigoplus_{n \in \mathbb{Z}} A_n$$

is said to be *admissible* if $\dim A^n < \infty$, $\forall n$, and $A_n = 0$, $\forall n \ll 0$. To an admissible graded vector space A_\bullet we associate its *Poincaré series*

$$P_{A_\bullet}(t) = \sum_n (\dim_{\mathbb{F}} A_n) t^n \in \mathbb{Z}[[t, t^{-1}]].$$

We define an order relation \succ on the ring $\mathbb{Z}[[t, t^{-1}]]$ by declaring that

$$X(t) \succ Y(t) \iff \text{there exists } Q \in \mathbb{Z}[[t, t^{-1}]] \text{ with nonnegative coefficients}$$

such that

$$X(t) = Y(t) + (1+t)Q(t). \quad (2.7)$$

Remark 2.13. (a) Assume that

$$X(t) = \sum_n x_n t^n \in \mathbb{Z}[[t, t^{-1}]], \quad Y(t) = \sum_n y_n t^n \in \mathbb{Z}[[t, t^{-1}]]$$

are such that $X \succ Y$. Then there exists $Q \in \mathbb{Z}[[t, t^{-1}]]$ such that

$$X(t) = Y(t) + (1+t)Q(t), \quad Q(t) = \sum_n q_n t^n, \quad q_n \geq 0.$$

Then we can rewrite the above equality as

$$(1+t)^{-1}X(t) = (1+t)^{-1}Y(t) + Q(t).$$

Using the identity

$$(1+t)^{-1} = \sum_{n \geq 0} (-1)^n t^n$$

we deduce

$$\sum_{k \geq 0} (-1)^k x_{n-k} - \sum_{k \geq 0} (-1)^k y_{n-k} = q_n \geq 0.$$

Thus the order relation \succ is equivalent to the *abstract Morse inequalities*

$$X \succ Y \iff \sum_{k \geq 0} (-1)^k x_{n-k} \geq \sum_{k \geq 0} (-1)^k y_{n-k}, \quad \forall n \geq 0. \quad (2.8)$$

Note that (2.7) implies immediately the *weak Morse inequalities*

$$x_n \geq y_n, \quad \forall n \geq 0. \quad (2.9)$$

(b) Observe that \succ is an order relation satisfying

$$X \succ Y \iff X + R \succ Y + R, \quad \forall R \in \mathbb{Z}[[t, t^{-1}]],$$

$$X \succ Y, \quad Z \succ 0 \implies X \cdot Z \succ Y \cdot Z. \quad \square$$

Lemma 2.14 (Subadditivity). *Suppose we have a long exact sequence of admissible graded vector spaces $A_\bullet, B_\bullet, C_\bullet$:*

$$\cdots \rightarrow A_k \xrightarrow{i_k} B_k \xrightarrow{j_k} C_k \xrightarrow{\partial_k} A_{k-1} \rightarrow \cdots.$$

Then

$$P_{A_\bullet} + P_{C_\bullet} \succ P_{B_\bullet}. \quad (2.10)$$

Proof. Set

$$\begin{aligned} a_k &= \dim A_k, & b_k &= \dim B_k, & c_k &= \dim C_k, \\ \alpha_k &= \dim \ker i_k, & \beta_k &= \dim \ker j_k, & \gamma_k &= \dim \ker \partial_k. \end{aligned}$$

Then

$$\begin{aligned} & \begin{cases} a_k = \alpha_k + \beta_k \\ b_k = \beta_k + \gamma_k \\ c_k = \gamma_k + \alpha_{k-1} \end{cases} \implies a_k - b_k + c_k = \alpha_k + \alpha_{k-1} \\ & \implies \sum_k (a_k - b_k + c_k)t^k = \sum_k t^k (\alpha_k + \alpha_{k-1}) \\ & \implies P_{A_\bullet}(t) - P_{B_\bullet}(t) + P_{C_\bullet}(t) = (1+t)Q(t), \quad Q(t) = \sum_k \alpha_k t^k. \end{aligned}$$

□

For every compact topological space X we denote by $b_k(X) = b_k(X, \mathbb{F})$ the k th *Betti number* (with coefficients in \mathbb{F})

$$b_k(X) := \dim H_k(X, \mathbb{F}),$$

and by $P_X(t) = P_{X, \mathbb{F}}(t)$ the Poincaré polynomial

$$P_{X, \mathbb{F}}(t) = \sum_k b_k(X, \mathbb{F})t^k.$$

If Y is a subspace of X then the relative Poincaré polynomial $P_{X,Y}(t)$ is defined in a similar fashion. The *Euler characteristic* of X is

$$\chi(X) = \sum_{k \geq 0} (-1)^k b_k(X),$$

and we have the equality

$$\chi(X) = P_X(-1).$$

Corollary 2.15 (Topological Morse inequalities). *Suppose $f : M \rightarrow \mathbb{R}$ is a Morse function on a smooth compact manifold of dimension M with Morse polynomial*

$$P_f(t) = \sum_{\lambda} \mu_f(\lambda) t^{\lambda}.$$

Then for every field of coefficients \mathbb{F} we have

$$P_f(t) \succ P_{M, \mathbb{F}}(t).$$

In particular,

$$\sum_{\lambda \geq 0} (-1)^{\lambda} \mu_f(\lambda) = P_f(-1) = P_{M, \mathbb{F}}(-1) = \chi(M).$$

Proof. Let $c_1 < c_1 < \dots < c_{\nu}$ be the critical values of f . Set (see Figure 2.13)

$$t_0 = c_1 - 1, t_{\nu} = c_{\nu} + 1, t_k = \frac{c_k + c_{k+1}}{2}, k = 1, \dots, \nu - 1, M_i = \{f \leq t_i\}.$$

For simplicity, we drop the field of coefficients from our notations.

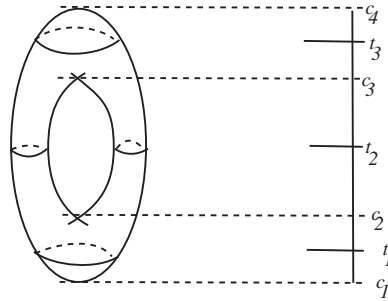

Fig. 2.13. Slicing a manifold by a Morse function.

From the long exact homological sequence of the pair (M_i, M_{i-1}) and the subadditivity lemma we deduce

$$P_{M_{i-1}} + P_{M_i, M_{i-1}} \succ P_{M_i}.$$

Summing over $i = 1, \dots, \nu$, we deduce

$$\sum_{i=1}^{\nu} P_{M_{i-1}} + \sum_{i=1}^{\nu} P_{M_i, M_{i-1}} \succ \sum_{i=1}^{\nu} P_{M_i} \implies \sum_{k=1}^{\nu} P_{M^k, M^{k-1}} \succ P_{M^{\nu}}.$$

Using the equality $M_{\nu} = M$ we deduce

$$\sum_{i=1}^{\nu} P_{M_i, M_{i-1}} \succ P_M.$$

Denote by $\mathbf{Cr}_i \subset \mathbf{Cr}_f$ the critical points on the level set $\{f = c_i\}$. From the fundamental structural theorem and the excision property of the singular homology we deduce

$$H_{\bullet}(M_i, M_{i-1}; \mathbb{F}) \cong \bigoplus_{p \in \mathbf{Cr}_i} H_{\bullet}(\mathbf{H}_{\lambda(p)}, \partial_{-}\mathbf{H}_{\lambda(p)}; \mathbb{F}) \cong \bigoplus_{p \in \mathbf{Cr}_i} H_{\bullet}(e_{\lambda(p)}, \partial e_{\lambda(p)}; \mathbb{F}).$$

Now observe that $H_k(e_{\lambda}, \partial e_{\lambda}; \mathbb{F}) = 0, \forall k \neq \lambda$, while $H_{\lambda}(e_{\lambda}, \partial e_{\lambda}; \mathbb{F}) \cong \mathbb{F}$. Hence

$$P_{M_i, M_{i-1}}(t) = \sum_{p \in \mathbf{Cr}_i} t^{\lambda(p)}.$$

Hence

$$P_f(t) = \sum_{i=1}^{\nu} P_{M_i, M_{i-1}}(t) \succ P_M. \quad \square$$

Remark 2.16. The above proof yields the following more general result. If

$$X_1 \subset \dots \subset X_{\nu} = X$$

is an increasing filtration by closed subsets of the compact space X , then

$$\sum_{i=1}^{\nu} P_{X_i, X_{i-1}}(t) \succ P_X(t). \quad \square$$

Suppose \mathbb{F} is a field and f is a Morse function on a compact manifold. We say that a critical point $p \in \mathbf{Cr}_f$ of index λ is \mathbb{F} -*completable* if the boundary of the core $e_{\lambda}(p)$ defines a trivial homology class in $H_{\lambda-1}(M^{c-\varepsilon}, \mathbb{F})$, $c = f(p)$, $0 < \varepsilon \ll 1$. We say that f is \mathbb{F} -*completable* if all its critical points are \mathbb{F} -completable.

We say that f is an \mathbb{F} -*perfect* Morse function if its Morse polynomial is equal to the Poincaré polynomial of M with coefficients in \mathbb{F} , i.e., all the Morse inequalities become equalities.

Proposition 2.17. *Any \mathbb{F} -completable Morse function on a smooth, closed, compact manifold is \mathbb{F} -perfect.*

Proof. Suppose $f : M \rightarrow \mathbb{R}$ is a Morse function on the compact, smooth m -dimensional manifold. Denote by $c_1 < \dots < c_{\nu}$ the critical values of M and set (see Figure 2.13)

$$t_0 = c_1 - 1, t_{\nu} = c_{\nu} + 1, \quad t_i := \frac{c_i + c_{i+1}}{2}, \quad i = 1, \dots, \nu - 1.$$

Denote by $\mathbf{Cr}_i \subset \mathbf{Cr}_f$ the critical points on the level set $\{f = c_i\}$. Set $M_i := \{f \leq t_i\}$. From the fundamental structural theorem and the excision property of the singular homology we deduce

$$H_\bullet(M_i, M_{i-1}; \mathbb{F}) \cong \bigoplus_{p \in \mathbf{Cr}_i} H_\bullet(\mathbf{H}_{\lambda(p)}, \partial_- \mathbf{H}_{\lambda(p)}; \mathbb{F}) \cong \bigoplus_{p \in \mathbf{Cr}_i} H_\bullet(e_{\lambda(p)}, \partial e_{\lambda(p)}; \mathbb{F}).$$

Now observe that $H_k(e_\lambda, \partial e_\lambda; \mathbb{F}) = 0$, $\forall k \neq \lambda$, while $H_\lambda(e_\lambda, \partial e_\lambda; \mathbb{F}) \cong \mathbb{F}$. This last isomorphism is specified by fixing an orientation on $e_\lambda(p)$, which then produces a basis of $H_\lambda(H_\lambda, \partial_- H_\lambda; \mathbb{F})$ described by the relative homology class $[e_\lambda, \partial e_\lambda]$.

The connecting morphism

$$H_\bullet(M_i, M_{i-1}; \mathbb{F}) \xrightarrow{\partial} H_{\bullet-1}(M_{i-1}, \mathbb{F})$$

maps $[e_\lambda, \partial e_{\lambda(p)}]$ to the image of $[\partial e_\lambda]$ in $H_{\lambda(p)-1}(M_{i-1}, \mathbb{F})$. Since f is \mathbb{F} -completable we deduce that these connecting morphisms are trivial. Hence for every $1 \leq i \leq \nu$ we have a short exact sequence

$$0 \rightarrow H_\bullet(M_{i-1}, \mathbb{F}) \rightarrow H_\bullet(M_i, \mathbb{F}) \rightarrow \bigoplus_{p \in \mathbf{Cr}_i} H_\bullet(e_{\lambda(p)}, \partial e_{\lambda(p)}; \mathbb{F}) \rightarrow 0.$$

Hence

$$P_{M_i, \mathbb{F}}(t) = P_{M_{i-1}, \mathbb{F}}(t) + \sum_{p \in \mathbf{Cr}_i} t^{\lambda(p)}.$$

Summing over $i = 1, \dots, \nu$ and observing that $M_0 = \emptyset$ and $M_\nu = M$, we deduce

$$P_{M, \mathbb{F}}(t) = \sum_{i=1}^{\nu} \sum_{p \in \mathbf{Cr}_i} t^{\lambda(p)} = P_f(t). \quad \square$$

Let us describe a simple method of recognizing completable functions.

Proposition 2.18. *Suppose $f : M \rightarrow \mathbb{R}$ is a Morse function on a compact manifold satisfying the gap condition*

$$|\lambda(p) - \lambda(q)| \neq 1, \quad \forall p, q \in \mathbf{Cr}_f.$$

Then f is \mathbb{F} -completable for any field \mathbb{F} .

Proof. We continue to use the notation in the proof of Proposition 2.17. Set

$$\Lambda := \{ \lambda(p); p \in \mathbf{Cr}_f \}, \quad \Lambda_i = \{ \lambda(p); p \in \mathbf{Cr}_i \} \subset \mathbb{Z}.$$

The gap condition shows that

$$\lambda \in \Lambda \implies \lambda \pm 1 \in \mathbb{Z} \setminus \Lambda. \quad (2.11)$$

Note that the fundamental structural theorem implies

$$H_k(M_i, M_{i-1}; \mathbb{F}) = 0 \iff k \in \mathbb{Z} \setminus \Lambda, \quad (2.12)$$

since M_i/M_{i-1} is homotopic to a wedge of spheres of dimensions belonging to Λ .

We will prove by induction over $i \geq 0$ that

$$k \in \mathbb{Z} \setminus \Lambda \implies H_k(M_i, \mathbb{F}) = 0, \quad (A_i)$$

and that the connecting morphism

$$\partial : H_k(M_i, M_{i-1}; \mathbb{F}) \longrightarrow H_{k-1}(M_{i-1}, \mathbb{F}) \quad (B_i)$$

is trivial for every $k \geq 0$.

The above assertions are trivially true for $i = 0$. Assume $i > 0$. We begin by proving (B_i) .

This statement is obviously true if $H_k(M_i, M_{i-1}; \mathbb{F}) = 0$, so we may assume $H_k(M_i, M_{i-1}; \mathbb{F}) \neq 0$. Note that (2.12) implies $k \in \Lambda$, and thus the gap condition (2.11) implies that $k - 1 \in \mathbb{Z} \setminus \Lambda$.

The inductive assumption (A_{i-1}) implies that $H_{k-1}(M_{i-1}, \mathbb{F}) = 0$, so that the connecting morphism

$$\partial : H_k(M_i, M_{i-1}; \mathbb{F}) \rightarrow H_{k-1}(M_{i-1}, \mathbb{F})$$

is zero. This proves (B_i) . In particular, for every $k \geq 0$ we have an exact sequence

$$0 \rightarrow H_k(M_{i-1}, \mathbb{F}) \rightarrow H_k(M_i, \mathbb{F}) \rightarrow H_k(M_i, M_{i-1}; \mathbb{F}).$$

Suppose $k \in \mathbb{Z} \setminus \Lambda$. Then $H_k(M_i, M_{i-1}; \mathbb{F}) = 0$, so that $H_k(M_i, \mathbb{F}) \cong H_k(M_{i-1}, \mathbb{F})$. From (A_{i-1}) we now deduce $H_k(M_{i-1}, \mathbb{F}) = 0$. This proves (A_i) as well.

To conclude the proof of the proposition observe that (B_i) implies that f is \mathbb{F} -completable. \square

Corollary 2.19. *Suppose $f : M \rightarrow \mathbb{R}$ is a Morse function on a compact manifold whose critical points have only even indices. Then f is a perfect Morse function.* \square

Example 2.20. Consider the round sphere

$$S^n = \{ (x^0, \dots, x^n) \in \mathbb{R}^{n+1}; \sum_i |x^i|^2 = 1 \}.$$

The height function

$$h_n : S^n \rightarrow \mathbb{R}, \quad (x^0, \dots, x^n) \mapsto x^0$$

is a Morse function with two critical points: a global maximum at the north pole $x^0 = 1$ and a global minimum at the south pole, $x^0 = -1$.

For $n > 1$ this is a perfect Morse function, and we deduce

$$P_{S^n}(t) = P_{h_n}(t) = 1 + t^n.$$

Consider the manifold $M = S^m \times S^n$. For $|n - m| \geq 2$ the function

$$h_{m,n} : S^m \times S^n \rightarrow \mathbb{R}, \quad S^m \times S^n \ni (x, y) \mapsto h_m(x) + h_n(y),$$

is a Morse function with Morse polynomial

$$P_{h_{m,n}}(t) = P_{h_m}(t)P_{h_n}(t) = 1 + t^m + t^n + t^{m+n},$$

and since $|n - m| \geq 2$, we deduce that it is a perfect Morse function. □

Example 2.21. Consider the complex projective space $\mathbb{C}\mathbb{P}^n$ with projective coordinates $[z_0, \dots, z_n]$ and define

$$f : \mathbb{C}\mathbb{P}^n \rightarrow \mathbb{R}, \quad f([z_0, z_1, \dots, z_n]) = \frac{\sum_{j=1}^n j|z_j|^2}{|z_0|^2 + \dots + |z_n|^2}.$$

We want to prove that f is a perfect Morse function.

The projective space $\mathbb{C}\mathbb{P}^n$ is covered by the coordinate charts

$$V_k = \{ z_k \neq 0 \}, \quad k = 0, 1, \dots, n,$$

with affine complex coordinates

$$v^i = v^i(k) = \frac{z_i}{z_k}, \quad i \in \{0, 1, \dots, n\} \setminus \{k\}.$$

Fix k and set

$$|v|^2 := |v(k)|^2 = \sum_{i \neq k} |v^i|^2.$$

Then

$$f|_{V_k} = \underbrace{\left(k + \sum_{j \neq k} j|v^j|^2 \right)}_{=: k+a(v)} \underbrace{(1 + |v|^2)^{-1}}_{=: b(v)}.$$

Observe that $db = -b^2 d|v|^2$ and

$$\begin{aligned} df|_{V_k} &= bda - (k + a)b^2 d|v|^2 = b^2 \sum_{j \neq k} (j(1 + |v|^2) - (k + a)) d|v^j|^2 \\ &= \sum_{j \neq k} ((j - k) + (|v|^2 - a)) d|v^j|^2. \end{aligned}$$

Since

$$d|v^j|^2 = \bar{v}^j dv^j + v^j d\bar{v}^j,$$

and the collection $\{dv^j, d\bar{v}^j; j \neq k\}$ defines a trivialization of $T^*V_k \otimes \mathbb{C}$ we deduce that v is a critical point of $f|_{V_k}$ if and only if

$$(j(1 + |v|^2) - (k + a))v^j = 0, \quad \forall j \neq k.$$

Hence $f|_{V_k}$ has only one critical point p_k with coordinates $v(k) = 0$. Near this point we have the Taylor expansions

$$(1 + |v|^2)^{-1} = 1 - |v|^2 + \dots,$$

$$f|_{V_k} = (k + a(v))(1 - |v|^2 + \dots) = k + \sum_{j \neq k} (j - k)|v^j|^2 + \dots.$$

This shows that Hessian of f at p_k is

$$H_{f,p_k} = 2 \sum_{j \neq k} (j - k)(x_j^2 + y_j^2), \quad v^j = x_j + y_j i.$$

Hence p_k is nondegenerate and has index $\lambda(p_k) := 2k$. This shows that f is a \mathbb{Q} -perfect Morse function with Morse polynomial

$$P_{\mathbb{C}\mathbb{P}^n}(t) = P_f(t) = \sum_{j=0}^n t^{2j} = \frac{1 - t^{2(n+1)}}{1 - t^2}.$$

Let us point out an interesting fact which suggests some of the limitations of the homological techniques we have described in this section.

Consider the perfect Morse function $h_{2,4} : S^2 \times S^4 \rightarrow \mathbb{R}$ described in Example 2.20. Its Morse polynomial is

$$P_{2,4} = 1 + t^2 + t^4 + t^6$$

and thus coincides with the Morse polynomial of the perfect Morse function $f : \mathbb{C}\mathbb{P}^3 \rightarrow \mathbb{R}$ investigated in this example. However $S^2 \times S^4$ is not even homotopic to $\mathbb{C}\mathbb{P}^3$, because the cohomology ring of $S^2 \times S^4$ is not isomorphic to the cohomology ring of $\mathbb{C}\mathbb{P}^3$. \square

Remark 2.22. The above example may give the reader the impression that on any smooth compact manifold there should exist perfect Morse functions. This is not the case. In Exercise 5.14 we describe a class of manifolds which do not admit perfect Morse functions. The Poincaré sphere is one such example. \square

2.4 Morse–Smale Dynamics

Suppose $f : M \rightarrow \mathbb{R}$ is a Morse function on the compact manifold M and ξ is a gradient-like vector field relative to f . We denote by Φ_t the flow on M determined by $-\xi$.

Lemma 2.23. *For every $p_0 \in M$ the limits*

$$\Phi_{\pm\infty}(p_0) := \lim_{t \rightarrow \pm\infty} \Phi_t(p_0)$$

exist and are critical points of f . □

Proof. Set $\gamma(t) := \Phi_t(p_0)$. If $\gamma(t)$ is the constant path, then the statement is obvious. Assume that $\gamma(t)$ is not constant.

Since $\xi \cdot f \geq 0$ and $\dot{\gamma}(t) = -\xi(\gamma(t))$, we deduce that

$$\dot{f} := \frac{d}{dt} f(\gamma(t)) = df(\dot{\gamma}) = -\xi \cdot f \leq 0.$$

From the condition $\xi \cdot f > 0$ on $M \setminus \mathbf{C}r_f$ and the assumption that $\gamma(t)$ is not constant we deduce

$$\dot{f}(t) < 0, \quad \forall t.$$

Define $\Omega_{\pm\infty}$ to be the set of points $q \in M$ such that there exists a sequence $t_n \rightarrow \pm\infty$ with the property that

$$\lim_{n \rightarrow \infty} \gamma(t_n) = q.$$

Since M is compact we deduce $\Omega_{\pm\infty} \neq \emptyset$. We want to prove that $\Omega_{\pm\infty}$ consist of a single point which is a critical point of f . We discuss only Ω_∞ , since the other case is completely similar.

Observe first that

$$\Psi_t(\Omega_\infty) \subset \Omega_\infty, \quad \forall t \geq 0.$$

Indeed, if $q \in \Omega_\infty$ and $\gamma(t_n) \rightarrow q$, then

$$\gamma(t_n + t) = \Psi_t(\gamma(t_n)) \rightarrow \Psi_t(q) \in \Omega_\infty.$$

Suppose q_0, q_1 are two points in Ω_∞ . Then there exists an increasing sequence $t_n \rightarrow \infty$ such that

$$\gamma(t_{2n+i}) \rightarrow q_i, \quad i = 0, 1, \quad t_{2n+1} \in (t_{2n}, t_{2n+2}).$$

We deduce

$$f(\gamma(t_{2n})) > f(\gamma(t_{2n+1})) > f(\gamma(t_{2n+2})).$$

Letting $n \rightarrow \infty$ we deduce $f(q_0) = f(q_1)$, $\forall q_0, q_1 \in \Omega_\infty$, so that there exists $c \in \mathbb{R}$ such that

$$\Omega_\infty \subset f^{-1}(c).$$

If $q \in \Omega_\infty \setminus \mathbf{Cr}_f$, then $t \mapsto \Psi_t(q) \in \Omega_\infty$ is a nonconstant trajectory of $-\xi$ contained in a level set $f^{-1}(c)$. This is impossible since f decreases strictly on such nonconstant trajectories. Hence

$$\Omega_\infty \subset \mathbf{Cr}_f.$$

To conclude it suffices to show that Ω_∞ is connected. Denote by \mathcal{C} the set of connected components of Ω_∞ . Assume that $\#\mathcal{C} > 1$. Fix a metric d on M and set

$$\delta := \min\{\text{dist}(C, C'); C, C' \in \mathcal{C}, C \neq C'\} > 0.$$

Let $C_0 \neq C_1 \in \mathcal{C}$ and $q_i \in C_i$, $i = 0, 1$. Then there exists an increasing sequence $t_n \rightarrow \infty$ such that

$$\gamma(t_{2n+i}) \rightarrow q_i, \quad i = 0, 1, \quad t_{2n+1} \in (t_{2n}, t_{2n+2}).$$

Observe that

$$\begin{aligned} \lim \text{dist}(\gamma(t_{2n}), C_0) &= \text{dist}(q_0, C_0) = 0, \\ \lim \text{dist}(\gamma(t_{2n+1}), C_0) &= \text{dist}(q_1, C_0) \geq \delta. \end{aligned}$$

From the mean value theorem we deduce that for all $n \gg 0$ there exists $s_n \in (t_{2n}, t_{2n+1})$ such that

$$\text{dist}(\gamma(s_n), C_0) = \frac{\delta}{2}.$$

A subsequence of $\gamma(s_n)$ converges to a point $q \in \Omega_\infty$ such that $\text{dist}(q, C_0) = \frac{\delta}{2}$. This is impossible since $q \in \Omega_\infty \subset \mathbf{Cr}_f \setminus C_0$. This concludes the proof of Lemma 2.23. \square

Suppose $f : M \rightarrow \mathbb{R}$ is a Morse function and $p_0 \in \mathbf{Cr}_f$, $c_0 = f(p_0)$. Fix a gradient-like vector field ξ on M and denote by Φ_t the flow on M generated by $-\xi$. We set

$$W^\pm(p_0) = W^\pm(p_0, \xi) := \Phi_{\pm\infty}^{-1}(p_0) = \{x \in M; \lim_{t \rightarrow \pm\infty} \Phi_t(x) = p_0\}.$$

$W^\pm(p_0, \xi)$ is called the *stable/unstable manifold* of p_0 (relative to the gradient-like vector field ξ). We set

$$S^\pm(p_0, \varepsilon) = W^\pm(p_0) \cap \{f = c_0 \pm \varepsilon\}.$$

Proposition 2.24. *Let $m = \dim M$, $\lambda = \lambda(f, p_0)$. Then $W^-(p_0)$ is a smooth manifold homeomorphic to \mathbb{R}^λ , while $W^+(p_0)$ is a smooth manifold homeomorphic to $\mathbb{R}^{m-\lambda}$.*

Proof. We will only prove the statement for the unstable manifold since $-\xi$ is a gradient-like vector field for $-f$ and $W^+(p_0, \xi) = W^-(p_0, -\xi)$. We will need the following auxiliary result.

Lemma 2.25. *For any sufficiently small $\varepsilon > 0$ the set $S^-(p_0, \varepsilon)$ is a sphere of dimension $\lambda - 1$ smoothly embedded in the level set $\{f = c_0 - \varepsilon\}$ with trivializable normal bundle.*

Proof. Pick local coordinates $x = (x_-, x_+)$ adapted to p_0 . Fix $\varepsilon > 0$ sufficiently small so that in the neighborhood

$$U = \{ |x_-|^2 + |x_+|^2 < r \}$$

the vector field ξ has the form

$$-2x_- \partial_{x_-} + x_+ \partial_{x_+} = -2 \sum_{i \leq \lambda} x^i \partial_{x^i} + 2 \sum_{j > \lambda} x^j \partial_{x^j}.$$

A trajectory $\Phi_t(q)$ of $-\xi$ which converges to p_0 as $t \rightarrow -\infty$ must stay inside U for all $t \ll 0$. Inside U , the only such trajectories have the form $e^{2t}x_-$, and they are all included in the disk

$$\mathbb{D}^-(p_0, r) = \{ x_+ = 0, |x_-|^2 \leq r \}.$$

Moreover, since f decreases strictly on nonconstant trajectories, we deduce that if $\varepsilon < r$, then

$$S^-(p_0, \varepsilon) = \partial \mathbb{D}^-(p_0, \varepsilon). \quad \square$$

Fix now a diffeomorphism $u : S^{\lambda-1} \rightarrow S^-(p_0, \varepsilon)$. If (r, θ) , $\theta \in S^{\lambda-1}$, denote the polar coordinates on \mathbb{R}^λ , we can define

$$F : \mathbb{R}^\lambda \rightarrow W^{-1}(p_0), \quad F(r, \theta) = \Phi_{\frac{1}{2} \log r}(u(\theta)).$$

The arguments in the proof of Lemma 2.25 show that F is a diffeomorphism. \square

Remark 2.26. The stable and unstable manifolds of a critical point are not closed subset of M . In fact, their closures tend to be quite singular, and one can say that the topological complexity of M is hidden in the structure of these singularities. \square

We have the following fundamental result of S. Smale [Sm].

Theorem 2.27. *Suppose $f : M \rightarrow \mathbb{R}$ is a Morse function on a compact manifold. Then there exists a gradient-like vector field ξ such that for any $p_0, p_1 \in \mathbf{Cr}_f$ the unstable manifold $W^-(p_0, \xi)$ intersects the stable manifold $W^+(p_1, \xi)$ transversally.*

Proof. For the sake of clarity we prove the theorem in the special case when f is nonresonant. The general case is only notationally more complicated. Let

$$\Delta_f = \{c_1 < \cdots < c_\nu\}$$

be the set of critical values of f . Denote by p_i the critical point of f on the level set $\{f = c_i\}$. Clearly $W^-(p)$ intersects $W^+(p)$ transversally at p . In general, $W^+(p_i) \cap W^-(p_j)$ is a union of trajectories of $-\xi$ and

$$W^+(p_i) \cap W^-(p_j) \neq \emptyset \implies f(p_i) \leq f(p_j) \iff i \leq j.$$

Note that if r is a regular value of f , then manifolds $W^\pm(p, \xi)$ intersect the level set $\{f = r\}$ transversally, since ξ is transversal to the level set and tangent to W^\pm . For every regular value r we set

$$W^\pm(p_i, \xi)_r := W^\pm(p_i, \xi) \cap \{f = r\}.$$

Observe that

$$W^-(p_j, \xi) \pitchfork W^+(p_i, \xi) \iff W^-(p_j, \xi)_r \pitchfork W^+(p_i, \xi)_r,$$

for some regular value $f(p_i) < r < f(p_j)$.

For any real numbers $a < b$ such that the interval $[a, b]$ contains only regular values and any gradient-like vector field ξ we have a diffeomorphism

$$\Phi_{b,a}^\xi : \{f = a\} \longrightarrow \{f = b\}$$

obtained by following the trajectories of the flow of the vector field $\langle \xi \rangle := \frac{1}{\xi \cdot f} \xi$ along which f increases at a rate of one unit per second. We denote by $\Phi_{a,b}^\xi$ its inverse. Note that

$$W^\pm(p_i, \xi)_a = \Phi_{a,b}^\xi(W^\pm(p_i, \xi)_b), \quad W^\pm(p_i, \xi)_b = \Phi_{b,a}^\xi(W^\pm(p_i, \xi)_a).$$

For every $r \in \mathbb{R}$ we set $M_r := \{f = r\}$.

Lemma 2.28 (Main deformation lemma). *Suppose $a < b$ are such that $[a, b]$ consists only of regular values of f . Suppose $h : M_b \rightarrow M_b$ is a diffeomorphism of M_b isotopic to the identity. This means that there exists a smooth map*

$$H : [0, 1] \times M_b \rightarrow M_b, \quad (t, x) \mapsto h_t(x),$$

such that $x \mapsto h_t(x)$ is a diffeomorphism of M_b , $\forall t \in [0, 1]$, $h_0 = \mathbb{1}_{M_b}$, $h_1 = h$. Then there exists a gradient-like vector field η for f which coincides with ξ outside $\{a < f < b\}$ such that the diagram below is commutative:

$$\begin{array}{ccc} M_b & \xrightarrow{h} & M_b \\ & \searrow \Phi_{b,a}^\xi & \nearrow \Phi_{b,a}^\eta \\ & M_a & \end{array}$$

Proof. For the simplicity of exposition we assume $a = 0, b = 1$ and that $t \mapsto h_t$ is independent of t for t close to 0 and 1. Note that we have a diffeomorphism

$$\Psi : [0, 1] \times M_1 \rightarrow \{0 \leq f \leq 1\}, \quad (t, x) \mapsto \Phi_{t,1}^\xi(x) \in \{f = t\}.$$

Its inverse is

$$y \mapsto (f(y), \Phi_{1,f(y)}^\xi(y)).$$

Using the isotopy H we obtain a diffeomorphism

$$\hat{H} := [0, 1] \times M_1 \rightarrow [0, 1] \times M_1, \quad \hat{H}(t, x) = (t, h_t(x)).$$

It is now clear that the pushforward of the vector field $\langle \xi \rangle$ via the diffeomorphism

$$F = \Psi \circ H \circ \Psi^{-1} : \{0 \leq f \leq 1\} \rightarrow \{0 \leq f \leq 1\}$$

is a vector field $\hat{\eta}$ which coincides with $\langle \xi \rangle$ near M_0, M_1 and satisfies $\hat{\eta} \cdot f = 1$. The vector field

$$\eta = (\xi \cdot f)\hat{\eta}$$

extends to a vector field that coincides with ξ outside $\{0 < f < 1\}$ and satisfies $\langle \eta \rangle = \hat{\eta}$. Moreover, the flow of $\langle \eta \rangle$ fits in the commutative diagram

$$\begin{array}{ccc} M_1 & \xrightarrow{F} & M_1 \\ \uparrow \Phi_{1,0}^\xi & & \uparrow \Phi_{1,0}^\eta \\ M_0 & \xrightarrow{F} & M_0 \end{array}$$

Now observe that $F|_{M_0} = \mathbb{1}_{M_0}$ and

$$F_{M_1} = \Phi_{1,1}^\xi h_1 \Phi_{1,1}^\xi = h_1 = h. \quad \square$$

Lemma 2.29 (Moving lemma). *Suppose X, Y are two smooth submanifolds of the compact smooth manifold V and X is compact. Then there exists a diffeomorphism of $h : V \rightarrow V$ isotopic to the identity² such that $h(X)$ intersects Y transversally.* □

We omit the proof which follows from the transversality results in [Hir, Chapter 3] and the isotopy extension theorem, [Hir, Chapter 8].

We can now complete the proof of Theorem 2.27. Let $1 \leq k \leq \nu$. Suppose we have constructed a gradient-like vector field ξ such that

$$W^+(p_i) \pitchfork W^-(p_j, \xi), \quad \forall i < j \leq k.$$

² The diffeomorphism h can be chosen to be arbitrarily C^0 -close to the identity.

We will show that for $\varepsilon > 0$ sufficiently small there exists a gradient-like vector field η which coincides with ξ outside the region $\{c_{k+1} - 2\varepsilon < f < c_{k+1} - \varepsilon\}$ and such that

$$W^-(p_{k+1}, \eta) \pitchfork W^+(p_j, \eta), \quad \forall j \leq k.$$

For $\varepsilon > 0$ sufficiently small, $W^-(p_{k+1}, \xi)_{c_{k+1}-\varepsilon}$ is a sphere of dimension $\lambda(p_{k+1}) - 1$ embedded in $\{f = c_{k+1} - \varepsilon\}$. We set

$$a := c_{k+1} - 2\varepsilon, \quad b = c_{k+1} - \varepsilon,$$

and

$$X_b = \bigcup_{j \leq k} W^+(p_j, \xi)_b.$$

Using the moving lemma, we can find a diffeomorphism $h : M_b \rightarrow M_b$ isotopic to the identity such that (see Figure 2.14)

$$h(X_b) \pitchfork W^-(p_{k+1}, \xi)_b. \tag{2.13}$$

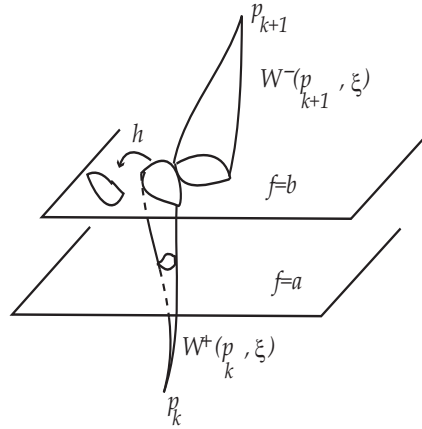

Fig. 2.14. Deforming a gradient-like flow.

Using the main deformation lemma we can find a gradient-like vector field η which coincides with ξ outside $\{a < f < b\}$ such that

$$\Phi_{b,a}^\eta = h \circ \Phi_{b,a}^\xi.$$

Since η coincides with ξ outside $\{a < f < b\}$, we deduce

$$W^+(p_j, \eta)_a = W^+(p_j, \xi)_a, \quad \forall j \leq k, \quad W^-(p_{k+1}, \xi)_b = W^-(p_{k+1}, \eta)_b.$$

Now observe that

$$W^+(p_j, \eta)_b = \Phi_{b,a}^\eta W^+(p_j, \eta)_a = h\Phi_{b,a}^\xi W^+(p_j, \xi)_a = hW^+(p_j, \xi)_b,$$

and we deduce from (2.13) that

$$W^+(p_j, \eta)_b \pitchfork W^-(p_{k+1}, \eta)_b, \quad \forall j \leq k.$$

Performing this procedure gradually, from $k = 1$ to $k = \nu$, we obtain a gradient-like vector field with the properties stipulated in Theorem 2.27. \square

Definition 2.30. (a) If $f : M \rightarrow \mathbb{R}$ is a Morse function and ξ is a gradient like vector field such that

$$W^-(p, \xi) \pitchfork W^+(q, \xi), \quad \forall p, q \in \mathbf{Cr}_f,$$

then we say that (f, ξ) is a Morse–Smale pair on M and that ξ is a Morse–Smale vector field adapted to f . \square

Remark 2.31. Observe that if (f, ξ) is a Morse–Smale pair on M and $p, q \in \mathbf{Cr}_f$ are two distinct critical points such that $\lambda_f(p) \leq \lambda_f(q)$, then

$$W^-(p, \xi) \cap W^+(q, \xi) = \emptyset.$$

Indeed, suppose this is not the case. Then

$$\dim W^-(p, \xi) + \dim W^+(q, \xi) = \dim M + (\lambda(p) - \lambda(q)) \leq \dim M,$$

and because $W^-(p, \xi)$ intersects $W^+(q, \xi)$ transversally, we deduce that

$$\dim(W^-(p, \xi) \cap W^+(q, \xi)) = 0.$$

Since the intersection $W^-(p, \xi) \cap W^+(q, \xi)$ is flow invariant and $p \neq q$, this zero dimensional intersection must contain at least one nontrivial flow line. \square

Definition 2.32. A Morse function $f : M \rightarrow \mathbb{R}$ is called self-indexing if

$$f(p) = \lambda_f(p), \quad \forall p \in \mathbf{Cr}_f. \quad \square$$

Theorem 2.33 (Smale). Suppose M is a compact smooth manifold of dimension m . Then there exist Morse–Smale pairs (f, ξ) on M such that f is self-indexing.

Proof. We follow closely the strategy in [M4, Section 4]. We begin by describing the main technique that allows us to gradually modify f to a self-indexing Morse function.

Lemma 2.34 (Rearrangement lemma). *Suppose $f : M \rightarrow \mathbb{R}$ is a Morse function such that $0, 1$ are regular values of f and the region $\{0 < f < 1\}$ contains precisely two critical points p_0, p_1 . Furthermore, assume that ξ is a gradient-like vector field on M such that*

$$W(p_0, \xi) \cap W(p_1, \xi) \cap \{0 \leq f \leq 1\} = \emptyset,$$

where we have used the notation $W(p_i) = W^+(p_i) \cup W^-(p_i)$.

Then for any real numbers $a_0, a_1 \in [0, 1]$ there exists a Morse function $g : M \rightarrow \mathbb{R}$ with the following properties:

- (a) g coincides with f outside the region $\{0 < f < 1\}$.
- (b) $g(p_i) = a_i, \forall i = 0, 1$.
- (c) $f - g$ is constant in a neighborhood of $\{p_0, p_1\}$.
- (d) ξ is a gradient-like vector field for g .

Proof. Let

$$W := \left(W^+(p_0, \xi) \cup W^-(p_0, \xi) \cup W^+(p_1, \xi) \cup W^-(p_1, \xi) \right) \cap \{0 \leq f \leq 1\},$$

$$M_0 := \{f = 0\}, \quad M'_0 = M_0 \setminus (W^-(p_0, \xi) \cup W^-(p_1, \xi)),$$

$$W^-(p_i, \xi)_0 := W^-(p_i, \xi) \cap M_0.$$

Denote by $\langle \xi \rangle$ the vector field $\frac{1}{\xi \cdot f} \xi$ on $\{0 \leq f \leq 1\} \setminus W$ and by Φ_t^ξ its flow. Then Φ_t^ξ defines a diffeomorphism

$$\Psi : [0, 1] \times M'_0 \rightarrow \{0 \leq f \leq 1\} \setminus W, \quad (t, x) \mapsto \Phi_t^\xi(x).$$

Its inverse is

$$y \mapsto \Psi^{-1}(y) = (f(y), \Phi_{-f(y)}^\xi(y)).$$

Choose open neighborhoods U_i of $W^-(p_i, \xi)_0$ in M_0 such that $U \cap U' = \emptyset$. This is possible since $W(p_0) \cap W(p_1) \cap M_0 = \emptyset$.

Now fix a smooth function $\mu : M_0 \rightarrow [0, 1]$ such that $\mu = i$ on U_i . Denote by \hat{U}_i the set of points y in $\{0 \leq f \leq 1\}$ such that either $y \in W^+(p_i, \xi)$ or the trajectory of $-\xi$ through y intersects M_0 in $U_i, i = 0, 1$ (see Figure 2.15). We can extend μ to a smooth function $\hat{\mu}$ on $\{0 \leq f \leq 1\}$ as follows.

If $y \notin (\hat{U}_0 \cup \hat{U}_1)$, then $\Psi^{-1}(y) = (t, x), x \in M_0 \setminus (U_0 \cup U_1)$, and we set

$$\hat{\mu}(y) := \mu(x).$$

Then we set $\hat{\mu}(y) = i \forall y \in \hat{U}_i$.

Now fix a smooth function $G : [0, 1] \times [0, 1] \rightarrow [0, 1]$ satisfying the following conditions:

- $\frac{\partial G}{\partial t}(s, t) > 0, \forall 0 \leq s, t \leq 1$.
- $G(s, 0) = 0, G(s, 1) = 1$.

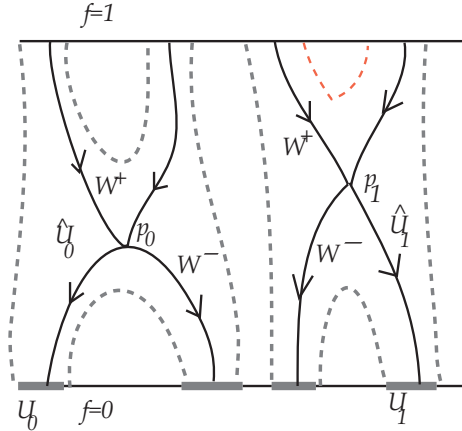

Fig. 2.15. Decomposing a Morse flow.

- $G(s, t) = t$ near the segments $t = 0, 1$.
- $G(i, t) - t = (a_i - f(p_i))$ for t near $f(p_i)$.

We can think of G as a 1-parameter family of increasing diffeomorphisms

$$G_s : [0, 1] \rightarrow [0, 1], \quad s \mapsto G_s(t) = G(s, t)$$

such that $g_0(f(p_0)) = a_0$ and $g_1(f(p_1)) = a_1$.

Now define

$$h : \{0 \leq f \leq 1\} \rightarrow [0, 1], \quad h(y) = G(\hat{\mu}(y), f(y)).$$

It is now easy to check that g has all the desired properties. □

Remark 2.35. (a) To understand the above construction it helps to think of the Morse function f as a clock, i.e. a way of measuring time. For example, the time at the point y is $f(y)$.

We can think of the family $s \mapsto G_s$ as 1-parameter family of “clock modifiers”. If a clock indicates time $t \in [0, 1]$, then by modifying the clock with G_s it will indicate time $G_s(t)$.

The function h can be perceived as a different way of measuring time, obtained by modifying the “old clock” f using the modifier G_s . More precisely, the new time at y will be $G_{\hat{\mu}(y)}(f(y))$.

(b) The rearrangement lemma works in the more general context, when instead of only two critical points, we have a partition $C_0 \sqcup C_1$ of the set of critical points in the region $\{0 < f < 1\}$ such that f is constant on C_0 and on C_1 , and $W(p_0, \xi) \cap W(p_1, \xi) = \emptyset, \forall p_0 \in C_0, \forall p_1 \in C_1$. □

We can now complete the proof of Theorem 2.33. Suppose (f, ξ) is a Morse–Smale pair on M such that f is nonresonant. Remark 2.31 shows that

$$p \neq q \text{ and } \lambda(p) \leq \lambda(q) \implies W^-(p, \xi) \cap W^+(q, \xi) = \emptyset.$$

We say that a pair of critical points $p, q \in \mathbf{Cr}_f$ is an *inversion* if

$$\lambda(p) < \lambda(q) \text{ and } f(p) > f(q).$$

We see that if (p, q) is an inversion, then

$$W^-(p, \xi) \cap W^+(q, \xi) = \emptyset.$$

Using the rearrangement lemma and Theorem 2.27 we can produce inductively a new Morse–Smale pair (g, η) such that $\mathbf{Cr}_g = \mathbf{Cr}_f$, and g is nonresonant and has no inversions.

To see how this is done, define the *level function*

$$\ell_f : \mathbf{Cr}_f \rightarrow \mathbb{Z}_{\geq 0}, \quad \ell_f(p) := \#\{q \in \mathbf{Cr}_f; f(q) < f(p)\},$$

denote by $\nu(f)$ the number of inversions of f , and then set

$$\mu(f) = \max\{\ell_f(q); (p, q) \text{ inversion of } f\}.$$

If $\nu(f) > 0$, then there exists an inversion (p, q) such that $\ell_f(p) = \mu(f) + 1$ and $\ell_f(q) = \mu(f)$. We can then use the rearrangement lemma to replace f with f' such that $\nu(f') < \nu(f)$.

This implies that there exist regular values $r_0 < r_1 < \dots < r_m$ such that all the critical points in the region $\{r_\lambda < g < r_{\lambda+1}\}$ have the same index λ .

Using the rearrangement lemma again (see Remark 2.35(b)) we produce a new Morse–Smale pair (h, τ) with critical values $c_0 < \dots < c_m$, and all the critical points on $\{h = c_\lambda\}$ have the same index λ .

Finally, via an increasing diffeomorphism of \mathbb{R} we can arrange that $c_\lambda = \lambda$. \square

Observe that the above arguments prove the following slightly stronger result.

Corollary 2.36. *Suppose (f, ξ) is a Morse–Smale pair on the compact manifold M . Then we can modify f to a smooth Morse function $g : M \rightarrow \mathbb{R}$ with the following properties:*

- (a) $\mathbf{Cr}_g = \mathbf{Cr}_f$ and $\lambda(f, p) = \lambda(g, p) = g(p)$, $\forall p \in \mathbf{Cr}_f = \mathbf{Cr}_g$.
- (b) ξ is a gradient-like vector field for g .

In particular, (g, ξ) is a self-indexing Morse–Smale pair.

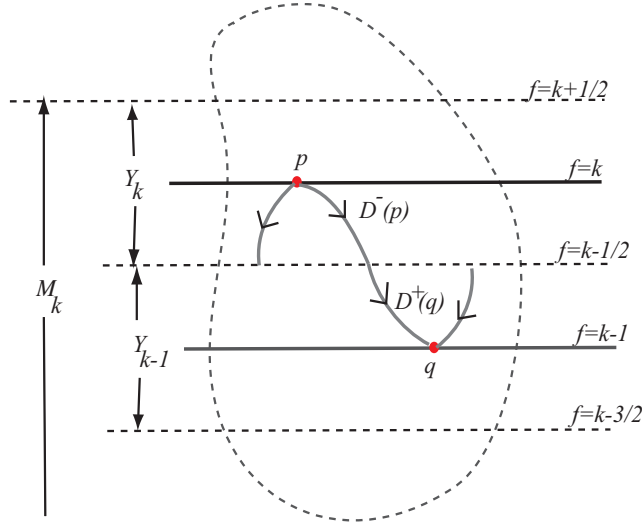

Fig. 2.16. Constructing the Thom–Smale complex.

2.5 Morse–Floer Homology

Suppose (f, ξ) is a Morse–Smale pair on the compact m -dimensional manifold M such that f is self-indexing. In particular, the real numbers $k + \frac{1}{2}$ are regular values of f . We set

$$M_k = \left\{ f \leq k + \frac{1}{2} \right\}, \quad Y_k = \left\{ k - \frac{1}{2} \leq f \leq k + \frac{1}{2} \right\}.$$

Then Y_k is a smooth manifold with boundary (see Figure 2.16)

$$\partial Y_k = \partial_- Y_k \cup \partial_+ Y_k, \quad \partial_{\pm} Y_k = \left\{ f = k \pm \frac{1}{2} \right\}.$$

Set

$$C_k(f) := H_k(M_k, M_{k-1}; \mathbb{Z}), \quad \mathbf{Cr}_k = \{p \in \mathbf{Cr}_f; \lambda(p) = k\} \subset \{f = k\}.$$

Finally, for $p \in \mathbf{Cr}_k$ denote by $D^{\pm}(p)$ the unstable disk

$$D^{\pm}(p) := W^{\pm}(p, \xi) \cap Y_k.$$

Using excision and the fundamental structural theorem of Morse theory we obtain an isomorphism

$$C_k(f) \cong \bigoplus_{p \in \mathbf{Cr}_k} H_k(D^-(p), \partial D^-(p); \mathbb{Z}).$$

By fixing an orientation $\mathbf{or}^-(p)$ on each unstable manifold $W^-(p)$ we obtain isomorphisms

$$H_k(D^-(p), \partial D^-(p); \mathbb{Z}) \rightarrow \mathbb{Z}, \quad p \in \mathbf{Cr}_k.$$

We denote by $\langle p|$ the generator of $H_k(D^-(p), \partial D^-(p); \mathbb{Z})$ determined by the choice of orientation $\mathbf{or}^-(p)$.

Observe that we have a natural morphism $\partial : C_k \rightarrow C_{k-1}$ defined as the composition

$$H_k(M_k, M_{k-1}; \mathbb{Z}) \rightarrow H_{k-1}(M_{k-1}, \mathbb{Z}) \rightarrow H_{k-1}(M_{k-1}, M_{k-2}; \mathbb{Z}). \quad (2.14)$$

Arguing exactly as in the proof of [Ha, Theorem 2.35] (on the equivalence of cellular homology with the singular homology)³ we deduce that

$$\cdots \rightarrow C_k(f) \xrightarrow{\partial} C_{k-1}(f) \rightarrow \cdots \quad (2.15)$$

is a chain complex whose homology is isomorphic to the homology of M . This is called the *Thom–Smale complex* associated to the self-indexing Morse function f .

We would like to give a more geometric description of the Thom–Smale complex. More precisely, we will show that it is isomorphic to a chain complex which can be described entirely in terms of Morse data.

Observe first that the connecting morphism

$$\partial_k : H_k(M_k, M_{k-1}) \rightarrow H_{k-1}(M_{k-1})$$

can be geometrically described as follows. The relative class $\langle p| \in C_k$ is represented by the fundamental class of the *oriented* manifold with boundary $(D^-(p), \partial D^-(p))$. The orientation $\mathbf{or}^-(p)$ induces an orientation on $\partial D^-(p)$, and thus the oriented closed manifold $\partial D^-(p)$ defines a homology class in $H_{k-1}(M_{k-1}, \mathbb{Z})$ which represents $\partial \langle p|$.

Assume for simplicity that the ambient manifold M is *oriented*. (As explained Remark 2.39 (a) this assumption is not needed.) The orientation \mathbf{or}_M on M and the orientation $\mathbf{or}^-(p)$ on $D^-(p)$ determine an orientation $\mathbf{or}^+(p)$ on $D^+(p)$ via the equalities

$$T_p M = T_p D^-(p) \oplus T_p D^+(p), \quad \mathbf{or}^-(p) \wedge \mathbf{or}^+(p) = \mathbf{or}_M.$$

Since ξ is a Morse–Smale gradient like vector field, we deduce that $\partial D^-(p)$ and $D^+(q)$ intersect transversally. In particular, if $p \in \mathbf{Cr}_k$ and $q \in \mathbf{Cr}_{k-1}$, then

³ *For the cognoscenti.* The increasing filtration $\cdots \subset M_{k-1} \subset M_k \subset \cdots$ defines an increasing filtration on the singular chain complex $C_\bullet(M, \mathbb{Z})$. The associated (homological) spectral sequence has the property that $E_{p,q}^2 = 0$ for all $q > 0$ so that the spectral sequence degenerates at E^2 and the edge morphism induces an isomorphism $H_p(M) \rightarrow E_{p,0}^2$. The E^1 term is precisely the chain complex (2.15).

$$\dim \partial D^-(p) + \dim D^+(p) = (k-1) + \dim M - (k-1) = m,$$

so that $\partial D^-(p)$ intersects $D^+(p)$ transversally in finitely many points. We denote by $\langle p|q \rangle$ the *signed* intersection number

$$\langle p|q \rangle := \#(D^-(p) \cap \partial D^+(q)), \quad p \in \mathbf{Cr}_k, \quad q \in \mathbf{Cr}_{k-1}.$$

Observe that each point s in $D^+(q) \cap \partial D^-(p)$ corresponds to a unique trajectory $\gamma(t)$ of the flow generated by $-\xi$ such that $\gamma(-\infty) = p$ and $\gamma(\infty) = q$. We will refer to such a trajectory as a *tunnelling* from p to q . Thus $\langle p|q \rangle$ is a signed count of tunnellings from p to q .

Proposition 2.37 (Thom–Smale). *There exists $\epsilon_k \in \{\pm 1\}$ such that*

$$\partial \langle p| = \epsilon_k \sum_{q \in \mathbf{Cr}_{k-1}} \langle p|q \rangle \cdot \langle q|, \quad \forall p \in \mathbf{Cr}_k. \quad (2.16)$$

Proof. We have

$$\partial \langle p| \in H_{k-1}(M_{k-1}, M_{k-2}; \mathbb{Z}) \cong H_{k-1}(Y_{k-1}, \partial_- Y_{k-1}; \mathbb{Z}).$$

From the Poincaré–Lefschetz duality theorem we deduce

$$H_{k-1}(Y_{k-1}, \partial_- Y_{k-1}; \mathbb{Z}) \cong H^{m-(k-1)}(Y_{k-1}, \partial_+ Y_{k-1}; \mathbb{Z}).$$

Since $H_j(Y_{k-1}, \partial_+ Y_{k-1}; \mathbb{Z})$ is a free Abelian group nontrivial only for $j = m - (k - 1)$ we deduce that the canonical map

$$H^{m-(k-1)}(Y_{k-1}, \partial_+ Y_{k-1}; \mathbb{Z}) \longrightarrow \text{Hom}(H_{m-(k-1)}(Y_{k-1}, \partial_+ Y_{k-1}; \mathbb{Z}), \mathbb{Z})$$

given by the Kronecker pairing is an isomorphism.

The group $H_{m-(k-1)}(Y_{k-1}, \partial_+ Y_{k-1}; \mathbb{Z})$ is freely generated by⁴

$$|q \rangle := [D^+(q), \partial D^+(q), \text{or}^+(q)], \quad q \in \mathbf{Cr}_{k-1}.$$

If we view $\partial \langle p|$ as a morphism $H_{m-(k-1)}(Y_{k-1}, \partial_+ Y_{k-1}; \mathbb{Z}) \longrightarrow \mathbb{Z}$, then its value on $|q \rangle$ is given (up to a sign ϵ_k which depends only on k) by the above intersection number $\langle p|q \rangle$. \square

Given a Morse–Smale pair (f, ξ) on an oriented manifold M and orientations of the unstable manifolds, we can form the *Morse–Floer complex*

$$(C_\bullet(f), \partial), \quad C_k(f) = \bigoplus_{p \in \mathbf{Cr}_k(f)} \mathbb{Z} \cdot \langle p|,$$

⁴ There is no typo! $|q \rangle$ is a *ket* vector and *not* a *bra* vector $\langle q|$.

where the boundary operator has the tunnelling description (2.16). Note that the definitions of $C_k(f)$ and ∂ depend on ξ but not on f .

In view of Corollary 2.36 we may as well assume that f is self-indexing. Indeed, if this is not the case, we can replace f by a different Morse function g with the same critical points and indices such that g is self-indexing and ξ is a gradient-like vector field for both f and g .

We conclude that ∂ is indeed a boundary operator, i.e., $\partial^2 = 0$, because it can alternatively be defined as the composition (2.14). We have thus proved the following result.

Corollary 2.38. *For any Morse–Smale pair (f, ξ) on the compact oriented manifold M there exists an isomorphism from the homology of the Morse–Floer complex to the singular homology of M . \square*

Remark 2.39. (a) The orientability assumption imposed on M is not necessary. We used it only for the ease of presentation. Here is how one can bypass it.

Choose for every $p \in \mathbf{Cr}_f$ orientations of the vector spaces T_p^-M of spanned by the eigenvectors of the Hessian of f corresponding to negative eigenvalues. The unstable manifold $W^-(p)$ is homeomorphic to a vector space and its tangent space at p is precisely T_p^-M . Thus, the chosen orientation on T_p^-M induces an orientation on $W^-(p)$. Similarly, the chosen orientation on T_p^-M defines an orientation on the normal bundle $T_{W^+(p)}M$ of the embedding $W^+(p) \hookrightarrow M$.

Now observe that if X and Y are submanifolds in M intersecting transversally, such that TX is oriented and the normal bundle $T_Y M$ of $Y \hookrightarrow M$ is oriented, then there is a canonical orientation of $X \cap Y$ induced from the short exact sequence of bundles

$$0 \rightarrow T(X \cap Y) \hookrightarrow (TX)|_{X \cap Y} \rightarrow (T_Y M)|_{X \cap Y} \rightarrow 0.$$

Hence, if $\lambda(p) - \lambda(q) = 1$, then $W^-(p) \cap W^+(q)$ is an oriented one-dimensional manifold.

On the other hand, each component of $W^-(p) \cap W^+(q)$ is a trajectory of the gradient flow and thus comes with another orientation given by the direction of the flow.

We conclude that on each component of $W^-(p) \cap W^+(q)$ we have a pair of orientations which differ by a sign ϵ . We can now define $n(p, q)$ to be the sum of all these ϵ 's. We then get an operator

$$\hat{\partial} : C_k(f) \rightarrow C_{k-1}(f), \quad \hat{\partial}\langle p | = \sum_q n(p, q)\langle q |.$$

One can prove that it coincides, up to an overall sign, with the previous boundary operator.

(b) For different proofs of the above corollary we refer to [BaHu, Sal, Sch].

(c) Corollary 2.38 has one unsatisfactory feature. The isomorphism is not induced by a morphism between the Morse–Floer complex and the singular chain complexes and thus does not highlight the geometric nature of this construction.

For any homology class in a smooth manifold M , the Morse–Smale flow Φ_t on M selects a very special singular chain representing this class. For example, if a homology class is represented by the singular cycle c , then is also represented by the cycle $\Phi_t(c)$ and, stretching our imagination, by the cycle $\Phi_\infty(c) = \lim_{t \rightarrow \infty} \Phi_t(c)$.

The Morse–Floer complex is, loosely speaking, the subcomplex of the singular complex generated by the family of singular simplices of the form $\Phi_\infty(\sigma)$, where σ is a singular simplex. The supports of such asymptotic simplices are invariant subsets of the Morse–Smale flow and thus must be unions of orbits of the flow.

The isomorphism between the Morse–Floer homology and the singular homology suggests that the subcomplex of the singular chain complex generated by asymptotic simplices might be homotopy equivalent to the singular chain complex. For a rigorous treatment of this idea we refer to [La] or [HL].

There is another equivalent way of visualizing the Morse flow complex which goes back to R. Thom [Th]. Think of a Morse–Smale pair (f, ξ) on M as defining a “polyhedral structure⁵”, and then the Morse–Floer complex is the complex naturally associated to this structure. The faces of this “polyhedral structure” are labelled by the critical points of f , and their interiors coincide with the unstable manifolds of the corresponding critical point.

The boundary of a face is a union (with integral multiplicities) of faces of one dimension lower. To better understand this point of view it helps to look at the simple situation depicted in Figure 2.17. Let us explain this figure.

First, we have the standard description of a Riemann surface of genus 2 obtained by identifying the edges of an 8-gon with the gluing rule

$$a_1 b_1 a_1^{-1} b_1^{-1} a_2 b_2 a_2^{-1} b_2^{-1}.$$

This polyhedral structure corresponds to a Morse function on the Riemann surface which has the following structure.

- There is a single critical point of index 2, denoted by F , and located in the center of the two-dimensional face. The relative interior of the top face is the unstable manifold of F , and all the trajectories contained in this face will leave F and end up either at a vertex or in the center of some edge.
- There are four critical points of index one, a_1, a_2, b_1, b_2 , located at the center of the edges labelled by the corresponding letter. The interiors of the edges are the corresponding one-dimensional unstable manifolds. The

⁵ The technically correct but less suggestive term would be that of Whitney regular stratification.

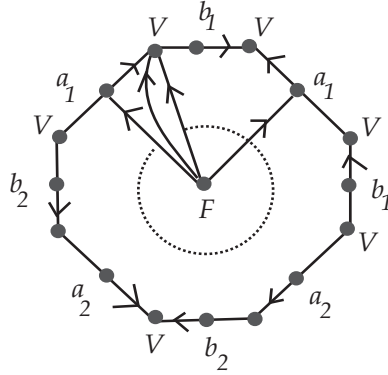

Fig. 2.17. The polyhedral structure determined by a Morse function on a Riemann surface of genus 2.

arrows along the edges describe orientations on these unstable manifolds. The gradient flow trajectories along an edge point away from the center.

- There is a unique critical point of index 0 denoted by V .

In the picture there are two tunnellings connecting F with a_1 , but they are counted with opposite signs. In general, we deduce

$$\langle F|a_i \rangle = \langle F|b_j \rangle = 0, \quad \forall i, j.$$

Similarly,

$$\langle a_i|V \rangle = \langle b_j|V \rangle = 0, \quad \forall i, j.$$

(d) The dynamical description of the boundary map of the Morse–Floer complex in terms of tunnellings is due to Witten, [Wit] (see the nice story in [B3]), and it has become popular through the groundbreaking work of A. Floer, [F].

The tunnelling approach has been used quite successfully in infinite dimensional situations leading to various flavors of the so called *Floer homologies*.

These are situations when the stable and unstable manifolds are infinite dimensional yet they intersect along finite dimensional submanifolds. One can still form the operator ∂ using the description in Proposition 2.37, but the equality $\partial^2 = 0$ is no longer obvious, because in this case an alternative description of ∂ of the type (2.14) is lacking. For more information on this aspect we refer to [ABr, Sch].

□

2.6 Morse–Bott Functions

Suppose $f : M \rightarrow \mathbb{R}$ is a smooth function on the m -dimensional manifold M .

Definition 2.40. A smooth submanifold $S \hookrightarrow M$ is said to be a nondegenerate critical submanifold of f if the following hold.

- S is compact and connected.
- $S \subset \mathbf{Cr}_f$.
- $\forall s \in S$ we have $T_s S = \ker H_{f,s}$, i.e.,

$$H_{f,s}(X, Y) = 0, \quad \forall Y \in T_s M \iff X \in T_s S (\subset T_s M).$$

The function f is called a Morse–Bott function if its critical set consists of nondegenerate critical submanifolds. \square

Suppose $S \hookrightarrow M$ is a nondegenerate critical submanifold of f . Assume for simplicity that $f|_S = 0$. Denote by $T_S M$ the normal bundle of $S \hookrightarrow M$, $T_S M := (TM)|_S / TS$. For every $s \in S$ and every $X, Y \in T_s S$ we have

$$H_{f,s}(X, Y) = 0,$$

so that the Hessian of f at s induces a quadratic form $Q_{f,s}$ on $T_s M / T_s S = (T_S M)_s$. We thus obtain a quadratic form Q_f on $T_S M$, which we regard as a function on the total space of $T_S M$, quadratic along the fibers.

The same arguments in the proof of Theorem 1.12 imply the following Morse lemma with parameters.

Proposition 2.41. There exists an open neighborhood U of $S \hookrightarrow E = T_S M$ and a smooth open embedding $\Phi : U \rightarrow M$ such that $\Phi|_S = \mathbb{1}_S$ and

$$\Phi^* f = \frac{1}{2} Q_f.$$

If we choose a metric g on E , then we can identify the Hessians $Q_{f,s}$ with a symmetric automorphism $Q : E \rightarrow E$. This produces an orthogonal decomposition

$$E = E_+ \oplus E_-,$$

where E_{\pm} is spanned by the eigenvectors of H corresponding to positive/negative eigenvalues. If we denote by r_{\pm} the restriction to E_{\pm} of the function

$$u(v, s) = g_s(v, v),$$

then we can choose the above Φ so that

$$\Phi^* f = -u_- + u_+.$$

The topological type of E_{\pm} is independent of the various choices, and thus it is an invariant of (S, f) denoted by $E_{\pm}(S)$ or $E_{\pm}(S, f)$. We will refer to $E_-(S)$ as the negative normal bundle of S . In particular, the rank of E_- is an invariant of S called the Morse index of the critical submanifold S , and it is denoted by $\lambda(f, S)$. The rank of E_+ is called the Morse coindex of S , and it is denoted by $\hat{\lambda}(f, S)$. \square

Definition 2.42. Let \mathbb{F} be a field. The \mathbb{F} -Morse–Bott polynomial of a Morse–Bott function $f : M \rightarrow \mathbb{R}$ defined on the compact manifold M is the polynomial

$$P_f(t) = P_f(t; \mathbb{F}) = \sum_S t^{\lambda(f, S)} P_{S, \mathbb{F}}(t),$$

where the summation is over all the critical submanifolds of f . Note that the Morse–Bott polynomial of a Morse function coincides with the Morse polynomial defined earlier. \square

Arguing exactly as in the proof of the fundamental structural theorem we obtain the following result.

Theorem 2.43 (Bott). Suppose $f : M \rightarrow \mathbb{R}$ is an exhaustive smooth function and $c \in \mathbb{R}$ is a critical value such that $\mathbf{Cr}_f \cap f^{-1}(c)$ consists of finitely many critical submanifolds S_1, \dots, S_k . For $i = 1, \dots, k$ denote by $D^-(S_i)$ the (closed) unit disk bundle of $E_-(S_i)$ (with respect to some metric on $E_-(S_i)$). Then for $\varepsilon > 0$ the sublevel set $M^{c+\varepsilon} = \{f \leq c + \varepsilon\}$ is homotopic to the space obtained from $M^{c-\varepsilon} = \{f \leq c - \varepsilon\}$ by attaching the disk bundles $D^-(S_i)$ to $M^{c-\varepsilon}$ along the boundaries $\partial D^-(S_i)$. In particular, for every field \mathbb{F} we have an isomorphism

$$H_\bullet(M^{c+\varepsilon}, M^{c-\varepsilon}; \mathbb{F}) = \bigoplus_{i=1}^k H_\bullet(D^-(S_i), \partial D^-(S_i); \mathbb{F}). \quad (2.17)$$

\square

Let \mathbb{F} be a field and X a compact CW -complex. For a real vector bundle $\pi : E \rightarrow X$ of rank r over X , we denote by $D(E)$ the unit disk bundle of E with respect to some metric. We say that E is \mathbb{F} -orientable if there exists a cohomology class

$$\tau \in H^r(D(E), \partial D(E); \mathbb{F})$$

such that its restriction to each fiber $(D(E)_x, \partial D(E)_x)$, $x \in X$ defines a generator of the relative cohomology group $H^r(D(E)_x, \partial D(E)_x; \mathbb{F})$. The class τ is called the *Thom class* of E associated to a given orientation.

For example, every vector bundle is $\mathbb{Z}/2$ -orientable, and every complex vector bundle is \mathbb{Q} -orientable. Every real vector bundle over a simply connected space is \mathbb{Q} -orientable.

The *Thom isomorphism theorem* states that if the vector bundle $\pi : E \rightarrow X$ is \mathbb{F} -orientable, then for every $k \geq 0$ the morphism

$$H^k(X, \mathbb{F}) \ni \alpha \longmapsto \tau_E \cup \pi^* \alpha \in H^{k+r}(D(E), \partial D(E); \mathbb{F})$$

is an isomorphism for any $k \in \mathbb{Z}$. Equivalently, the transpose map

$$H_{k+r}(D(E), \partial D(E); \mathbb{F}) \rightarrow H_k(X, \mathbb{F}), \quad c \mapsto \pi_*(c \cap \tau_E)$$

is an isomorphism. This implies

$$P_{D(E),\partial D(E)}(t) = t^r P_X(t). \tag{2.18}$$

Definition 2.44. *Suppose \mathbb{F} is a field, and $f : M \rightarrow \mathbb{R}$ is a Morse–Bott function. We say that f is \mathbb{F} -orientable if for every critical submanifold S the bundle $E_-(S)$ is \mathbb{F} -orientable. \square*

Corollary 2.45. *Suppose $f : M \rightarrow \mathbb{R}$ is an \mathbb{F} -orientable Morse–Bott function on the compact manifold. Then we have the Morse–Bott inequalities*

$$P_f(t) \succ P_{M,\mathbb{F}}(t).$$

In particular,

$$\sum_S (-1)^{\lambda(f,S)} \chi(S) = P_f(-1) = P_M(-1) = \chi(M).$$

Proof. Denote by $c_1 < \dots < c_\nu$ the critical values of f and set

$$t_k = \frac{c_k + c_{k+1}}{2}, \quad k = 1, \nu - 1, \quad t_0 = c_1 - 1, \quad t_\nu = c_\nu + 1, \quad M_k = \{f \leq t_k\}.$$

As explained in Remark 2.16, we have an inequality

$$\sum_k P_{M_k, M_{k-1}} \succ P_M.$$

Using the equality (2.17) we deduce

$$\sum_k P_{M_k, M_{k-1}} = \sum_S P_{D^-(S), \partial D^-(S)},$$

where the summation is over all the critical submanifolds of f . Since $E_-(S)$ is orientable for every S , we deduce from (2.18) that

$$P_{D^-(S), \partial D^-(S)} = t^{\lambda(f,S)} P_S. \quad \square$$

Definition 2.46. *Suppose $f : M \rightarrow \mathbb{R}$ is a Morse–Bott function on a compact manifold M . Then f is called \mathbb{F} -completable if for every critical value c and every critical submanifold $S \subset f^{-1}(c)$ the inclusion*

$$\partial D^-(S) \rightarrow \{f \leq c - \varepsilon\}$$

induces the trivial morphism in homology. \square

Arguing exactly as in the proof of Proposition 2.17 we obtain the following result.

Theorem 2.47. *Suppose $f : M \rightarrow \mathbb{R}$ is a \mathbb{F} -completable, \mathbb{F} -orientable, Morse–Bott function on a compact manifold. Then f is \mathbb{F} -perfect, i.e., $P_f(t) = P_M(t)$. \square*

Corollary 2.48. *Suppose $f : M \rightarrow \mathbb{R}$ is an orientable Morse–Bott function such that for every critical submanifold M we have $\lambda(f, S) \in 2\mathbb{Z}$ and $P_S(t)$ is even, i.e.,*

$$b_k(S) \neq 0 \implies k \in 2\mathbb{Z}.$$

Then f is \mathbb{Q} -perfect and thus $P_f(t) = P_M(t)$.

Proof. Using the same notation as in the proof of Corollary 2.45, we deduce by induction over k from the long exact sequences of the pairs (M_k, M_{k-1}) that $b_j(M_k) = 0$ if j is odd, and we have short exact sequence

$$0 \rightarrow H_j(M_{k-1}) \rightarrow H_j(M_k) \rightarrow H_j(M_k, M_{k-1}) \rightarrow 0$$

if j is even. \square

2.7 Min–Max Theory

So far we have investigated how to use information about the critical points of smooth function on a smooth manifold to extract information about the manifold itself. In this section we will turn the situation on its head. We will use topological methods to extract information about the critical points of a smooth function.

To keep the technical details to a minimum so that the geometric ideas are as transparent as possible, we will restrict ourselves to the case of a smooth function f on a *compact, connected* smooth manifold M without boundary equipped with a Riemannian metric g .

We can substantially relax the compactness assumption, and the same geometrical principles we will outline below will still apply, but will require more technical work.

Morse theory shows that if we have some information about the critical points of f we can obtain lower estimates for their number. For example, if all the critical points are nondegenerate, then their number is bounded from below by the sum of Betti numbers of M . What happens if we drop the nondegeneracy assumption? Can we still produce interesting lower bounds for the number of critical points?

We already have a very simple lower bound. Since a function on a compact manifold must have a minimum and a maximum, it must have at least two critical points. This lower bound is in some sense optimal because the height function on the round sphere has precisely two critical points. This optimality is very unsatisfactory since, as pointed out by G. Reeb in [Re], if the only

critical points of f are (nondegenerate) minima and maxima, then M must be homeomorphic to a sphere.

Min-max theory is quite a powerful technique for producing critical points that often are saddle type points. We start with the basic structure of this theory. For simplicity we denote by M^c the sublevel set $\{f \leq c\}$.

The min-max technology requires a special input.

Definition 2.49. *A collection of min-max data for the smooth function*

$$f : M \rightarrow \mathbb{R}$$

is a pair $(\mathcal{H}, \mathcal{S})$ satisfying the following conditions.

- \mathcal{H} is a collection of homeomorphisms of M such that for every regular value a of M there exist $\varepsilon > 0$ and $h \in \mathcal{H}$ such that

$$h(M^{a+\varepsilon}) \subset M^{a-\varepsilon}.$$

- \mathcal{S} is a collection of subsets of M such that

$$h(S) \in \mathcal{S}, \quad \forall h \in \mathcal{H}, \quad \forall S \in \mathcal{S}. \quad \square$$

The key existence result of min-max theory is the following.

Theorem 2.50 (Min-max principle). *Suppose $(\mathcal{H}, \mathcal{S})$ is a collection of min-max data for the smooth function $f : M \rightarrow \mathbb{R}$. Then the real number*

$$c = c(\mathcal{H}, \mathcal{S}) := \inf_{S \in \mathcal{S}} \sup_{x \in S} f(x)$$

is a critical value of f .

Proof. We argue by contradiction. Assume that c is a regular value. Then there exist $\varepsilon > 0$ and $h \in \mathcal{H}$ such that

$$h(M^{c+\varepsilon}) \subset M^{c-\varepsilon}.$$

From the definition of c we deduce that there exists $S \in \mathcal{S}$ such that $\sup_{x \in S} f(x) < c + \varepsilon$, that is,

$$S \subset M^{c+\varepsilon}.$$

Then $S' = h(S) \in \mathcal{S}$ and $h(S) \subset M^{c-\varepsilon}$. It follows that $\sup_{x \in S'} f(x) \leq c - \varepsilon$, so that

$$\inf_{S' \in \mathcal{S}} \sup_{x \in S'} f(x) \leq c - \varepsilon.$$

This contradicts the choice of c as a min-max value. □

The usefulness of the min-max principle depends on our ability to produce interesting min-max data. We will spend the remainder of this section describing a few classical constructions of min-max data.

In all these constructions the family of homeomorphisms \mathcal{H} will be the same. More precisely, we fix gradient-like vector field ξ and we denote by Φ_t the flow generated by $-\xi$. The condition (a) in the definition of min-max data is clearly satisfied for the family

$$\mathcal{H}_f := \{\Phi_t; t \geq 0\}.$$

Constructing the family \mathcal{S} requires much more geometric ingenuity.

Example 2.51. Suppose \mathcal{S} is the collection

$$\mathcal{S} = \left\{ \{x\}; x \in M \right\}.$$

The condition (b) is clearly satisfied, and in this case we have

$$c(\mathcal{H}_f, \mathcal{S}) = \min_{x \in M} f(x).$$

This is obviously a critical value of f . □

Example 2.52 (Mountain-Pass points). Suppose x_0 is a strict local minimum of f , i.e. there exists a small, closed geodesic ball U centered at $x_0 \in M$ such that

$$c_0 = f(x_0) < f(x), \quad \forall x \in U \setminus \{x_0\}.$$

Note that

$$c'_0 := \min_{x \in \partial U} f(x) > c_0.$$

Assume that there exists another point $x_1 \in M \setminus U$ such that (see Figure 2.18)

$$c_1 = f(x_1) \leq f(x_0).$$

Now denote by \mathcal{P}_{x_0} the collection of smooth paths $\gamma : [0, 1] \rightarrow M$ such that

$$\gamma(0) = x_0, \quad \gamma(1) \in M^{c_0} \setminus U.$$

The collection \mathcal{P}_{x_0} is nonempty, since M is connected and $x_1 \in M^{c_0} \setminus U$. Observe that for any $\gamma \in \mathcal{P}_{x_0}$ and any $t \geq 0$ we have

$$\Phi_t \circ \gamma \in \mathcal{P}_{x_0}.$$

Now define

$$\mathcal{S} = \left\{ \gamma([0, 1]); \gamma \in \mathcal{P}_{x_0} \right\}.$$

Clearly the pair $(\mathcal{H}_f, \mathcal{S})$ satisfies all the conditions in Definition 2.49, and we deduce that

$$c = \inf_{\gamma \in \mathcal{P}_{x_0}} \max_{s \in [0, 1]} f(\gamma(s))$$

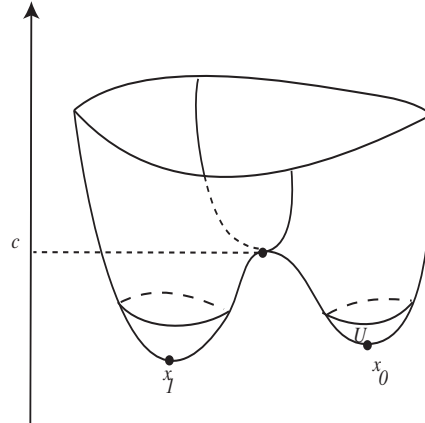

Fig. 2.18. A mountain pass from x_0 to x_1 .

is a critical value of f such that $c \geq c'_0 > c_0$ (see Figure 2.18).

This statement is often referred to as the *Mountain-pass lemma* and critical points on the level set $\{f = c\}$ are often referred to as *mountain-pass points*. Observe that the Mountain Pass Lemma implies that if a smooth function has two strict local minima then it must admit a third critical point.

The search strategy described in the Mountain-pass lemma is very intuitive if we think of f as a height function. The point x_0 can be thought of as a depression and the boundary ∂U as a mountain range surrounding x_0 . We look at all paths γ from x_0 to points of lower altitude, and on each of them we pick a point x_γ of greatest height. Then we select the path γ such that the point x_γ has the smallest possible altitude.

It is perhaps instructive to give another explanation of why there should exist a critical value greater than c_0 . Observe that the sublevel set M^{c_0} is disconnected while the manifold M is connected. The change in the topological type in going from M^{c_0} to M can be explained only by the presence of a critical value greater than c_0 . \square

To produce more sophisticated examples of min-max data we will use a technique pioneered by Lusternik and Schnirelmann. Denote by \mathcal{C}_M the collection of closed subsets of M . For a closed subset $C \subset M$ and $\varepsilon > 0$ we denote by $N_\varepsilon(C)$ the open tube of radius ε around C , i.e. the set of points in M at distance $< \varepsilon$ from C .

Definition 2.53. An index theory on M is a map

$$\gamma : \mathcal{C}_M \rightarrow \bar{\mathbb{Z}}_{\geq 0} := \{0, 1, \dots\} \cup \{\infty\}$$

satisfying the following conditions.

- **Normalization.** For every $x \in M$ there exists $r = r(x) > 0$ such that

$$\gamma(\{x\}) = 1 = \gamma(\overline{N_\varepsilon(x)}), \quad \forall x \in M, \quad \forall \varepsilon \in (0, r).$$

• **Topological invariance.** If $f : M \rightarrow M$ is a homeomorphism, then

$$\gamma(C) = \gamma(f(C)), \quad \forall C \in \mathcal{C}_M.$$

• **Monotonicity.** If $C_0, C_1 \in \mathcal{C}_M$ and $C_0 \subset C_1$, then $\gamma(C_0) \leq \gamma(C_1)$.

• **Subadditivity.** $\gamma(C_0 \cup C_1) \leq \gamma(C_0) + \gamma(C_1)$. □

Suppose we are given an index theory $\gamma : \mathcal{C}_M \rightarrow \overline{\mathbb{Z}}_{\geq 0}$. For every positive integer k we define

$$\Gamma_k := \left\{ C \in \mathcal{C}_M; \gamma(C) \geq k \right\}.$$

The axioms of an index theory imply that for each k the pair $(\mathcal{H}_f, \Gamma_k)$ is a collection of min-max data. Hence, for every k the min-max value

$$c_k = \inf_{C \in \Gamma_k} \max_{x \in C} f(x)$$

is a critical value. Since

$$\Gamma_1 \supset \Gamma_2 \supset \dots,$$

we deduce that

$$c_1 \leq c_2 \leq \dots.$$

Observe that the decreasing family $\Gamma_1 \supset \Gamma_2 \supset \dots$ stabilizes at Γ_m , where $m = \gamma(M)$. If by accident it happens that

$$c_1 > c_2 > \dots > c_{\gamma(M)},$$

then we could conclude that f has at least $\gamma(M)$ critical points. We want to prove that this conclusion holds even if some of these critical values are equal.

Theorem 2.54. *Suppose that for some $k, p > 0$ we have*

$$c_k = c_{k+1} = \dots = c_{k+p} = c,$$

and denote by K_c the set of critical points on the level set c . Then either c is an isolated critical value of f and K_c contains at least $p + 1$ critical points, or c is an accumulation point of \mathbf{Cr}_f , i.e. there exists a sequence of critical values $d_n \neq c$ converging to c .

Proof. Assume that c is an isolated critical value. We argue by contradiction. Suppose K_c contains at most p points. Then $\gamma(K_c) \leq p$. At this point we need a deformation result whose proof is postponed. Set

$$T_r(K_c) := \overline{N_r(K_c)}.$$

Lemma 2.55 (Deformation lemma). *Suppose c is an isolated critical value of f and $K_c = \mathbf{Cr}_f \cap \{f = c\}$ is finite. Then for every $\delta > 0$ there exist $0 < \varepsilon, r < \delta$ and a homeomorphism $h = h_{\delta, \varepsilon, r}$ of M such that*

$$h(\overline{M^{c+\varepsilon} \setminus T_r(K_c)}) \subset M^{c-\varepsilon}.$$

Consider ε, r sufficiently small as in the deformation lemma. Then the normalization and subadditivity axioms imply

$$\gamma(T_r(K_c)) \leq \gamma(K_c) = p.$$

We choose $C \in \Gamma_{k+p}$ such that

$$\max_{x \in C} f(x) \leq c_{k+p} + \varepsilon = c + \varepsilon.$$

Note that

$$C \subset T_r(K_c) \cup \overline{C \setminus T_r(K_c)},$$

and from the subadditivity of the index we deduce

$$\gamma(\overline{C \setminus T_r(K_c)}) \geq \gamma(C) - \gamma(T_r(K_c)) \geq k.$$

Hence

$$\gamma(h(\overline{C \setminus T_r(K_c)})) = \gamma(\overline{C \setminus T_r(K_c)}) \geq k,$$

so that

$$C' := h(\overline{C \setminus T_r(K_c)}) \in \Gamma_k.$$

Since

$$\overline{C \setminus T_r(K_c)} \subset \overline{M^{c+\varepsilon} \setminus T_r(K_v)},$$

we deduce from the deformation lemma that

$$C' \subset M^{c-\varepsilon}.$$

Now observe that the condition $C' \in \Gamma_k$ implies

$$c = c_k \leq \max_{x \in C'} f(x),$$

which is impossible since $C' \subset M^{c-\varepsilon}$. \square

Proof of the deformation lemma. The strategy is a refinement of the proof of Theorem 2.6. The homeomorphism will be obtained via the flow determined by a carefully chosen gradient-like vector field.

Fix a Riemannian metric g on M . For r sufficiently small, $N_r(K_c)$ is a finite disjoint union of open geodesic balls centered at the points of K_c . Let $r_0 > 0$ such that $N_{r_0}(K_c)$ is such a disjoint union and the only critical points

of f in $N_{r_0}(K_c)$ are the points in K_c . Fix ε_0 such that c is the only critical value in the interval $[c - \varepsilon_0, c + \varepsilon_0]$. For $r \in (0, r_0)$ define

$$b = b(r) := \inf \{ |\nabla f(x)|, x \in M^{c+\varepsilon_0} \setminus (M^{c-\varepsilon_0} \cup N_{r/8}(K_c)) \} > 0.$$

Choose $\varepsilon = \varepsilon(r) \in (0, \varepsilon_0)$ satisfying.

$$2\varepsilon < \min \left(\frac{b(r)r}{8}, b(r)^2, 1 \right) \implies \frac{2\varepsilon}{b(r)} < \frac{r}{8}, \quad \frac{2\varepsilon}{\min(1, b(r)^2)} \leq 1. \quad (2.19)$$

Define smooth cutoff functions

$$\alpha : M \rightarrow [0, 1], \quad \beta : M \rightarrow [0, 1]$$

such that

- $\alpha(x) = 0$ if $|f(x) - c| \geq \varepsilon_0$ and $\alpha(x) = 1$ if $|f(x) - c| \leq \varepsilon$;
- $\beta(x) = 1$ if $\text{dist}(x, K_c) \geq r/4$ and $\beta(x) = 0$ if $\text{dist}(x, K_c) < r/8$.

Finally, define a rescaling function

$$\varphi : [0, \infty) \rightarrow [0, \infty), \quad \varphi(s) := \begin{cases} 1 & s \in [0, 1], \\ s^{-1} & s \geq 1. \end{cases}$$

We can now construct the vector field ξ on M by setting

$$\xi(x) := -\alpha \cdot \beta \cdot \varphi(|\nabla^g f|^2) \nabla^g f.$$

Observe that ξ vanishes outside the region $\{c - \varepsilon_0 < f < c + \varepsilon_0\}$ and also vanishes in an $r/8$ -neighborhood of K_c . This vector field is not smooth, but it still is Lipschitz continuous. Note also that

$$|\xi(x)| \leq 1, \quad \forall x \in M.$$

The existence theorem for ODEs shows that for every $x \in M$ there exist $T_{\pm}(x) \in (0, \infty]$ and a C^1 -integral curve $\gamma_x : (-T_-(x), T_+(x)) \rightarrow M$ of ξ through x ,

$$\gamma_x(0) = x, \quad \dot{\gamma}_x(t) = \xi(\gamma_x(t)), \quad \forall t \in (-T_-(x), T_+(x)).$$

The compactness of M implies that the integral curves of ξ are defined for all $t \in \mathbb{R}$, i.e., $T_{\pm}(x) = \infty$. In particular, we obtain a (topological) flow Φ_t on M . To prove the deformation lemma it suffices to show that

$$\Phi_1(M^{c+\varepsilon} \setminus N_r(K_c)) \subset M^{c-\varepsilon}.$$

Note that by construction we have

$$\frac{d}{dt} f(\Phi_t(x)) \leq 0, \quad \forall x \in M,$$

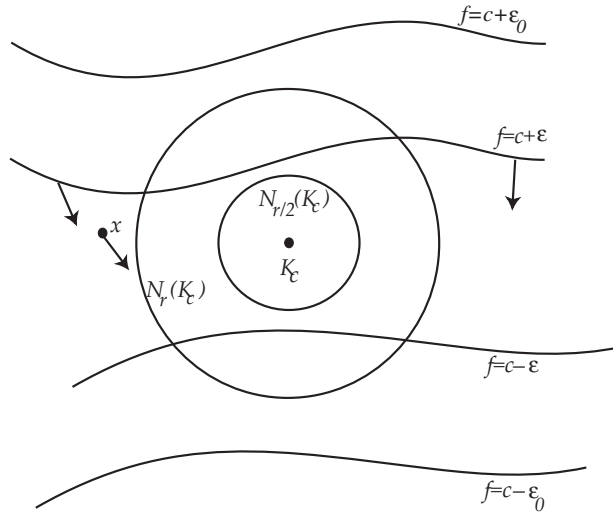

Fig. 2.19. A gradient-like flow.

so that

$$\Phi_1(M^{c-\epsilon}) \subset M^{c-\epsilon}.$$

Let $x \in M^{c+\epsilon} \setminus (N_r(K_c) \cup M^{c-\epsilon})$. We need to show that $\Phi_1(x) \in M^{c-\epsilon}$. We will achieve this in several steps.

For simplicity we set $x_t := \Phi_t(x)$. Consider the region

$$Z = \{c - \epsilon \leq f \leq c + \epsilon\} \setminus N_{r/2}(K_c),$$

and define

$$\mathcal{T}_x := \{t \geq 0; x_s \in Z, \forall s \in [0, t]\}.$$

Clearly $\mathcal{T}_x \neq \emptyset$.

Step 1. We will prove that if $t \in \mathcal{T}_x$, then

$$\text{dist}(x, x_s) < \frac{r}{8}, \quad \forall s \in [0, t].$$

In other words, during the time interval \mathcal{T}_x the flow line $t \mapsto x_t$ cannot stray too far from its initial point.

Observe that α and β are equal to 1 in the region Z and thus for every $t \in \mathcal{T}_x$ we have

$$\begin{aligned}
2\varepsilon &\geq f(x) - f(x_t) = - \int_0^t g(\nabla f(x_s), \xi(x_s)) ds \\
&= \int_0^t |\nabla f(x_s)|^2 \varphi(|\nabla f(x_s)|^2) ds \\
&\geq b(r) \int_0^t |\nabla f(x_s)| \varphi(|\nabla f(x_s)|^2) ds = b(r) \int_0^t \left| \frac{dx_s}{ds} \right| ds \\
&\geq b(r) \cdot \text{dist}(x, x_t).
\end{aligned}$$

From (2.19) we deduce

$$\text{dist}(x, x_t) \leq \frac{2\varepsilon}{b(r)} < \frac{r}{8}.$$

Step 2. We will prove that there exists $t > 0$ such that $\Phi_t(x) \in M^{c-\varepsilon}$. Loosely speaking, we want to show that there exists a moment of time t when the energy $f(x_t)$ drops below $c - \varepsilon$. Below this level the rate of decrease in energy will pickup.

We argue by contradiction, and thus we assume $f(x_t) > c - \varepsilon, \forall t > 0$. Thus

$$0 \leq f(x) - f(x_t) \leq 2\varepsilon, \quad \forall t > 0.$$

Since $x_s \in \{c - \varepsilon \leq f \leq c + \varepsilon\}, \forall s \geq 0$, we deduce

$$\mathcal{J}_x = \left\{ t \geq 0; \text{dist}(x_s, K_c) \geq \frac{r}{2}, \quad \forall s \in [0, t] \right\}.$$

Hence

$$\text{dist}(x_t, K_c) \geq \text{dist}(x, K_c) - d(x, x_t) > r - \frac{r}{8}, \quad \forall t \in \mathcal{J}_x$$

This implies that $T = \sup \mathcal{J}_x = \infty$. Indeed, if $T < \infty$ then

$$\begin{aligned}
\text{dist}(x_T, K_c) &\geq r - \frac{r}{8} > \frac{r}{2} \\
\implies \text{dist}(x_t, K_c) &> \frac{r}{2}, \quad \forall t \text{ sufficiently close to } T.
\end{aligned}$$

This contradicts the maximality of T .

Hence we deduce

$$x_t \in Z \iff c - \varepsilon < f(x_t) \leq c + \varepsilon, \quad \text{dist}(x_t, K_c) > \frac{r}{2}, \quad \forall t \geq 0.$$

This is impossible, since there exists a positive constant ν such that

$$|\xi(x)| > \nu, \quad \forall x \in Z,$$

which implies that

$$\frac{df(x_t)}{dt} \leq -b(r)\nu \implies \lim_{t \rightarrow \infty} f(x_t) = -\infty,$$

which is incompatible with the condition $0 \leq f(x) - f(x_t) \leq 2\varepsilon$ for every $t \geq 0$.

Step 3. We will prove that $\Phi_1(x) \in M^{c-\varepsilon}$ by showing that there exists $t \in (0, 1]$ such that $x_t \in M^{c-\varepsilon}$. Let

$$t_0 := \inf\{t \geq 0; x_t \in M^{c-\varepsilon}\}.$$

From Step 2 we see that t_0 is well defined and $f(x_{t_0}) = c - \varepsilon$. We claim that the path

$$[0, t_0] \ni s \mapsto x_s$$

does not intersect the neighborhood $N_{r/2}(K_c)$, i.e.,

$$\text{dist}(x_s, K_c) \geq \frac{r}{2}, \quad \forall s \in [0, t_0].$$

Indeed, from Step 1 we deduce

$$\text{dist}(x_s, K_c) > r - \frac{r}{8}, \quad \forall s \in [0, t_0].$$

Now observe that

$$\frac{df(x_s)}{ds} = -|\nabla f|^2 \varphi(|\nabla f|^2) \geq -\max(1, b(r)^2).$$

Thus, for every $s \in [0, t_0]$ we have

$$f(x) - f(x_s) \geq s \max(1, b(r)^2) \implies f(x_s) \leq c + \varepsilon - s \max(1, b(r)^2).$$

If we let $s = t_0$ in the above inequality and use the equality $f(x_{t_0}) = c - \varepsilon$, we deduce

$$c - \varepsilon \leq c + \varepsilon - t_0 \max(1, b(r)^2) \implies t_0 \leq \frac{2\varepsilon}{\max(1, b(r)^2)} \stackrel{(2.19)}{\leq} 1.$$

This completes the proof of the deformation lemma. \square

We now have the following consequence of Theorem 2.54.

Corollary 2.56. *Suppose $\gamma : \mathcal{C}_M \rightarrow \bar{\mathbb{Z}}_{\geq 0}$ is an index theory on M . Then any smooth function on M has at least $\gamma(M)$ critical points.* \square

To complete the story we need to produce interesting index theories on M . It turns out that the Lusternik–Schnirelmann category of a space is such a theory.

Definition 2.57. (a) A subset $S \subset M$ is said to be contractible in M if the inclusion map $S \hookrightarrow M$ is homotopic to the constant map.

(b) For every closed subset $C \subset M$ we define its Lusternik–Schnirelmann category of C in M and denote it by $\text{cat}_M(C)$, to be the smallest positive integer k such that there exists a cover of C by closed subsets

$$S_1, \dots, S_k \subset M$$

that are contractible in M . If such a cover does not exist, we set

$$\text{cat}_M(C) := \infty. \quad \square$$

Theorem 2.58 (Lusternik–Schnirelmann). If M is a compact smooth manifold, then the correspondence

$$\mathcal{C}_M \ni C \mapsto \text{cat}_M(C)$$

defines an index theory on M . Moreover, if R denotes one of the rings $\mathbb{Z}/2, \mathbb{Z}, \mathbb{Q}$ then

$$\text{cat}(M) := \text{cat}_M(M) \geq \text{CL}(M, R) + 1,$$

where $\text{CL}(M, R)$ denotes the cuplength of M with coefficients in R , i.e., the largest integer k such that there exists

$$\alpha_1, \dots, \alpha_k \in H^\bullet(M, R)$$

with the property that

$$\alpha_1 \cup \dots \cup \alpha_k \neq 0.$$

Proof. It is very easy to check that cat_M satisfies all the axioms of an index theory: normalization, topological invariance, monotonicity, and subadditivity, and we leave this task to the reader. The lower estimate of $\text{cat}(M)$ requires a bit more work. We argue by contradiction. Let

$$\ell := \text{CL}(M, R)$$

and assume that $\text{cat}(M) \leq \ell$. Then there exist $\alpha_1, \dots, \alpha_\ell \in H^\bullet(M, R)$ and closed sets $S_1, \dots, S_\ell \subset M$, contractible in M , such that

$$M = \bigcup_{k=1}^{\ell} S_k, \quad \alpha_1 \cup \dots \cup \alpha_\ell \neq 0.$$

Denote by j_k the inclusion $S_k \hookrightarrow M$.

Since S_k is contractible in M , we deduce that the induced map

$$j_k^* : H^\bullet(M, R) \rightarrow H^\bullet(S_k, R)$$

is trivial. In particular, the long exact sequence of the pair (M, S_k) shows that the natural map

$$i_k : H^\bullet(M, S_k; R) \rightarrow H^\bullet(M)$$

is onto. Hence there exists $\beta_k \in H^\bullet(M, S_k)$ such that

$$i_k(\beta_k) = \alpha_k.$$

Now we would like to take the cup products of the classes β_k , but we hit a technical snag. The cup product in *singular* cohomology,

$$H^\bullet(M, S_i; R) \times H^\bullet(M, S_j; R) \rightarrow H^\bullet(M, S_i \cup S_j; R),$$

is defined only if the sets S_i, S_j are “reasonably well behaved” (“excisive” in the terminology of [Spa, Section 5.6]). Unfortunately, we cannot assume this. There are two ways out of this technical conundrum. Either we modify the definition of cat_M to allow only covers by closed, contractible, and *excisive* sets, or we work with a more supple cohomology. We adopt this second option and we choose to work with Alexander cohomology $\bar{H}^\bullet(-, R)$, [Spa, Section 6.4].

This cohomology theory agrees with the singular cohomology for spaces which are not too “wild”. In particular, we have an isomorphism $\bar{H}^\bullet(M, R) \cong H^\bullet(M, R)$, and thus we can think of the α_k ’s as Alexander cohomology classes.

Arguing exactly as above, we can find classes $\beta_k \in \bar{H}^\bullet(M, S_k; R)$ such that

$$i_k(\beta_k) = \alpha_k.$$

In Alexander cohomology there is a cup product

$$\cup : \bar{H}^\bullet(M, A; R) \times \bar{H}^\bullet(M, B; R) \rightarrow \bar{H}^\bullet(M, A \cup B; R),$$

well defined for *any* closed subsets of M . In particular, we obtain a class

$$\beta_1 \cup \cdots \cup \beta_\ell \in \bar{H}^\bullet(M, S_1 \cup \cdots \cup S_\ell; R)$$

that maps to $\alpha_1 \cup \cdots \cup \alpha_\ell$ via the natural morphism

$$\bar{H}^\bullet(M, S_1 \cup \cdots \cup S_\ell; R) \rightarrow \bar{H}^\bullet(M, R).$$

Now observe that $\hat{H}^\bullet(M, S_1 \cup \cdots \cup S_\ell; R) = 0$, since $S_1 \cup \cdots \cup S_\ell = M$. We reached a contradiction since $\alpha_1 \cup \cdots \cup \alpha_\ell \neq 0$. □

Example 2.59. Since $\text{CL}(\mathbb{R}\mathbb{P}^n, \mathbb{Z}/2) = \text{CL}((S^1)^n, \mathbb{Z}) = \text{CL}(\mathbb{C}\mathbb{P}^n, \mathbb{Z}) = n$ we deduce

$$\text{cat}(\mathbb{R}\mathbb{P}^n) \geq n + 1, \quad \text{cat}((S^1)^n) \geq n + 1, \quad \text{cat}(\mathbb{C}\mathbb{P}^n) \geq n + 1.$$

□

Corollary 2.60. *Every even smooth function $f : S^n \rightarrow \mathbb{R}$ has at least $2(n+1)$ critical points.*

Proof. Observe that f descends to a smooth function \bar{f} on $\mathbb{R}P^n$ which has at least $\text{cat}(\mathbb{R}P^n) \geq n+1$ critical points. Every critical point of \bar{f} is covered by precisely two critical points of f . \square

Applications

It is now time to reap the benefits of the theoretical work we sowed in the previous chapter. Most applications of Morse theory that we are aware of share one thing in common. More precisely, they rely substantially on the special geometric features of a concrete situation to produce an interesting Morse function, and then squeeze as much information as possible from geometrical data. Often this process requires deep and rather subtle incursions into the differential geometry of the situation at hand. The end result will display surprising local-to-global interactions.

The applications we have chosen to present follow this pattern and will lead us into unexpected geometrical places that continue to be at the center of current research.

3.1 The Cohomology of Complex Grassmannians

Denote by $G_{k,n}$ the Grassmannian of complex k -dimensional subspaces of an n -dimensional complex vector space. The Grassmannian $G_{k,n}$ is a complex manifold of complex dimension $k(n-k)$ (see Exercise 5.22) and we have a diffeomorphism

$$G_{k,n} = G_{n-k,n}$$

which associates to each k -dimensional subspace its orthogonal complement with respect to a fixed Hermitian metric on the ambient space. Denote by $P_{k,n}(t)$ the Poincaré polynomial of $G_{k,n}$ with rational coefficients.

Proposition 3.1. *For every $1 \leq k \leq n$ the polynomial $P_{k,n}(t)$ is even, i.e., the odd Betti numbers of $G_{k,n}$ are trivial. Moreover,*

$$P_{k,n+1}(t) = P_{k,n}(t) + t^{2(n+1-k)}P_{k-1,n}(t)$$

$\forall 1 \leq k \leq n.$

Proof. We carry out an induction on $\nu = k + n$. The statement is trivially valid for $\nu = 2$, i.e., $(k, n) = (1, 1)$.

Suppose U is a complex n -dimensional vector space equipped with a Hermitian metric (\bullet, \bullet) . Set $V := \mathbb{C} \oplus U$ and denote by e_0 the standard basis of \mathbb{C} . The metric on U defines a metric on V , its direct sum with the standard metric on \mathbb{C} . For every complex Hermitian vector space W we denote by $G_k(W)$ the Grassmannian of k -dimensional complex subspaces of W and by $S(W)$ the linear space of Hermitian linear operators $T : W \rightarrow W$. Note that we have a natural map

$$G_k(W) \rightarrow S(W), \quad L \mapsto P_L,$$

where $P_L : W \rightarrow W$ denotes the orthogonal projection on L . This map is a smooth embedding. (See Exercise 5.22.)

Denote by $A : \mathbb{C} \oplus U \rightarrow \mathbb{C} \oplus U$ the orthogonal projection onto \mathbb{C} . Then $A \in S(V)$ and we define

$$f : S(V) \rightarrow \mathbb{R}, \quad f(T) = \mathbf{Re} \operatorname{tr}(AT).$$

This defines a smooth function on $G_k(V)$,

$$L \mapsto f(L) = \mathbf{Re} \operatorname{tr}(AP_L) = (P_L e_0, e_0).$$

Equivalently, $f(L) = \cos^2 \angle(e_0, L)$. Observe that we have natural embeddings $G_k(U) \hookrightarrow G_k(V)$ and

$$G_{k-1}(U) \rightarrow G_k(V), \quad G_{k-1}(U) \ni L \mapsto \mathbb{C}e_0 \oplus L.$$

Lemma 3.2.

$$\begin{aligned} 0 \leq f \leq 1, \quad \forall L \in G_k(V), \\ f^{-1}(0) = G_k(U), \quad f^{-1}(1) = G_{k-1}(U). \end{aligned}$$

Proof. If $L \subset V$ is a k -dimensional subspace, we have $0 \leq (P_L e_0, e_0) \leq 1$. Observe that

$$\begin{aligned} (P_L e_0, e_0) = 1 &\iff e_0 \in L, \\ (P_L e_0, e_0) = 0 &\iff e_0 \in L^\perp \iff L \subset (e_0)^\perp = U. \end{aligned}$$

Hence for $i = 0, 1$ we have $S_i = \{f = i\} = G_{k-i}(U)$. □

Lemma 3.3. *The only critical values of f are 0 and 1.*

Proof. Let $L \in G_k(V)$ such that $0 < f(L) < 1$. This means that

$$0 < (P_L e_0, e_0) = \cos^2 \angle(e_0, L) < 1.$$

In particular, L intersects the hyperplane $U \subset V$ transversally along a $k - 1$ -dimensional subspace $L' \subset L$. Fix an orthonormal basis e_1, \dots, e_{k-1} of L' and extend it to an orthonormal basis e_1, \dots, e_n of U . Then

$$L = L' + \mathbb{C}\mathbf{v}, \quad \mathbf{v} = c_0 e_0 + \sum_{j \geq k} c_j e_j, \quad |c_0|^2 + \sum_{j \geq k} |c_j|^2 = 1$$

and $(P_L e_0, e_0) = |c_0|^2$. If we choose

$$\mathbf{v}(t) = a_0(t) e_0 + \sum_{j \geq k} a_j(t) e_j, \quad |a_0(t)|^2 = 1 - \sum_{j \geq k} |a_j(t)|^2,$$

such that $a_0(t)$ and $a_j(t)$ depend smoothly on t , $\frac{d|a_0|^2}{dt}|_{t=0} \neq 0$, $a_0(0) = c_0$, then

$$t \longmapsto L_t = L' + \mathbb{C}\mathbf{v}(t)$$

is a smooth path in $G_k(V)$ and $\frac{df}{dt}(L_t)|_{t=0} \neq 0$. This proves that $L_0 = L$ is a regular point of f . \square

Lemma 3.4. *The level sets $S_i = f^{-1}(i)$, $i = 0, 1$, are nondegenerate critical manifolds.*

Proof. Observe that S_0 is a complex submanifold of $G_k(V)$ of complex dimension $k(n - k)$ and thus complex codimension

$$\text{codim}_{\mathbb{C}}(S_0) = k(n + 1 - k) - k(n - k) = k.$$

Similarly,

$$\text{codim}_{\mathbb{C}}(S_1) = (n + 1 - k)k - (n + 1 - k)(k - 1) = (n - k + 1).$$

To prove that S_0 is a nondegenerate critical manifold it suffices to show that for every $L \in S_0 = G_k(U)$ there exists a smooth map $\Phi : \mathbb{C}^k \rightarrow G_k(V)$ such that

$$\Phi(0) = L, \quad \Phi \text{ is an immersion at } 0 \in \mathbb{C}^k,$$

and

$$f \circ \Phi \text{ has a nondegenerate minimum at } 0 \in \mathbb{C}^k.$$

For every $u \in U$ denote by $X_u : V \rightarrow V$ the skew-Hermitian operator defined by

$$X_u(e_0) = u, \quad X_u(v) = -(v, u)e_0, \quad \forall v \in U.$$

Observe that the map $U \ni u \mapsto X_u \in \text{Hom}_{\mathbb{C}}(V, V)$ is \mathbb{R} -linear. The operator X_u defines a 1-parameter family of unitary maps $e^{tX_u} : V \rightarrow V$. Set

$$\bar{\Phi}(u) := e^{X_u} L, \quad P(u) := P_{\bar{\Phi}(u)}.$$

Then

$$P(u) = e^{X_u} P_L e^{-X_u}, \quad \dot{P}_u = \left. \frac{dP(tu)}{dt} \right|_{t=0} = [X_u, P_L]$$

and

$$(\dot{P}_u e_0, u) = -(P_L X_u(e_0), u) = -|u|^2,$$

so that if $u \in L$ we have

$$\dot{P}_u = 0 \implies u = 0.$$

This proves that the map

$$L \rightarrow G_k(V), \quad L \ni u \mapsto \Phi(u) \in G_k(V),$$

is an immersion at $u = 0$. Let us compute $f(\Phi(u))$. We have

$$\begin{aligned} f(\Phi(u)) &= (P(u)e_0, e_0) = (P_L e^{-X_u} e_0, e^{-X_u} e_0) \\ &= \left(P_L \left(1 - X_u + \frac{1}{2} X_u^2 - \cdots \right) e_0, \left(1 - X_u + \frac{1}{2} X_u^2 - \cdots \right) e_0 \right) \\ &= (P_L X_u e_0, X_u e_0) + \cdots = |u|^2 + \cdots, \end{aligned}$$

where at the last step we used the equalities $X_u e_0 = u$, $P_L u = u$, $P_L e_0 = 0$. Hence

$$\left. \frac{d^2 f(\Phi(tu))}{dt^2} \right|_{t=0} = 2(P_L X_u e_0, X_u e_0) = 2|u|^2.$$

This shows that $0 \in L$ is a nondegenerate minimum of $L \ni u \mapsto f(\Phi(u)) \in \mathbb{R}$, and since $\dim_{\mathbb{C}} L = \text{codim}_{\mathbb{C}} S_0$, we deduce that S_0 is a nondegenerate critical manifold.

Let $L \in S_1$. Denote by L_0 the intersection of L and U and by L'_0 the orthogonal complement of L_0 in U . Observe that

$$\dim_{\mathbb{C}} L'_0 = n - k + 1 = \text{codim}_{\mathbb{C}} S_1,$$

and we will show that the smooth map

$$\Phi : L'_0 \rightarrow G_k(V), \quad u \mapsto \Phi(u) = e^{X_u} L$$

is an immersion at $0 \in L'_0$ and that $f \circ \Phi$ has a nondegenerate maximum at 0.

Again we set $P(u) = P_{\Phi(u)}$ and we have

$$\begin{aligned} \dot{P}_u &:= \left. \frac{dP(tu)}{dt} \right|_{t=0} = [X_u, P_L], \\ \dot{P}_u e_0 &= X_u P_L e_0 - P_L X_u e_0 = X_u e_0 = u \implies (\dot{P}_u e_0, u) = |u|^2. \end{aligned}$$

Now observe that

$$\begin{aligned} f(\Phi(u)) &= (P_L e^{-X_u} e_0, e^{-X_u} e_0) \\ &= \left(P_L \left(1 - X_u + \frac{1}{2} X_u^2 + \cdots \right) e_0, \left(1 - X_u + \frac{1}{2} X_u^2 + \cdots \right) e_0 \right) \end{aligned}$$

$$\begin{aligned}
 (X_u e_0 = u, P_L X_u e_0 = 0) \\
 &= \left(e_0 + \frac{1}{2} X_u^2 e_0 + \cdots, e_0 - u + \frac{1}{2} X_u^2 e_0 \right) \\
 &= |e_0|^2 + \frac{1}{2} (X_u^2 e_0, e_0) + \frac{1}{2} (e_0, X_u^2 e_0) + \cdots \\
 (X_u^* = -X_u) \\
 &= 1 - (X_u e_0, X_u e_0) + \cdots = 1 - |u|^2 + \cdots .
 \end{aligned}$$

This shows that S_1 is a nondegenerate critical manifold. \square

Remark 3.5. The above computations can be refined to prove that the normal bundle of $S_0 = G_k(U) \hookrightarrow G_k(V)$ is isomorphic as a complex vector bundle to the dual of the tautological vector bundle on the Grassmannian $G_k(U)$, while the normal bundle of $S_1 = G_{k-1}(U) \hookrightarrow G_k(V)$ is isomorphic to the dual of the tautological quotient bundle on the Grassmannian $G_{k-1}(U)$. \square

We have

$$\lambda(f, S_0) = 0, \quad \lambda(f, S_1) = 2(n+1-k).$$

The negative bundles $E^-(S_i)$ are orientable since they are complex vector bundles

$$E^-(S_0) = 0, \quad E^-(S_1) = T_{S_1} G_k(V).$$

Since $S_0 \cong G_{k,n}$, $S_1 \cong G_{k-1,n}$, we deduce from the induction hypothesis that the Poincaré polynomials $P_{S_i}(t)$ are even. Hence the function f is a perfect Morse–Bott function, and we deduce

$$P_{G_k(V)} = P_{S_0}(t) + t^{2(n+1-k)} P_{S_1}(t),$$

or

$$P_{k,n+1}(t) = P_{k,n}(t) + t^{2(n+1-k)} P_{k-1,n}(t). \quad \square$$

Let us make a change in variables

$$Q_{k,\ell} = P_{k,n}, \quad \ell = (n-k).$$

The last identity can be rewritten

$$Q_{k,\ell+1} = Q_{k,\ell} + t^{2(\ell+1)} Q_{k-1,\ell+1}.$$

On the other hand, $Q_{k,\ell} = Q_{\ell,k}$, and we deduce

$$Q_{k,\ell+1} = Q_{\ell+1,k} = Q_{\ell+1,k-1} + t^{2k} Q_{\ell,k}.$$

Subtracting the last two equalities, we deduce

$$(1 - t^{2k}) Q_{k,\ell} = (1 - t^{2(\ell+1)}) Q_{k-1,\ell+1}.$$

We deduce

$$Q_{k,\ell} = \frac{(1 - t^{2(\ell+1)})}{(1 - t^{2k})} Q_{k-1,\ell+1} \implies P_{k,n} = \frac{(1 - t^{2(n-k+1)})}{(1 - t^{2k})} P_{k-1,n}.$$

Iterating, we deduce that the Poincaré polynomial of the complex Grassmannian $G_{k,n}$ is

$$P_{k,n}(t) = \frac{\prod_{j=(n-k+1)}^n (1 - t^{2j})}{\prod_{i=1}^k (1 - t^{2i})} = \frac{\prod_{i=1}^n (1 - t^{2i})}{\prod_{j=1}^k (1 - t^{2j}) \prod_{i=1}^{n-k} (1 - t^{2i})}.$$

3.2 Lefschetz Hyperplane Theorem

A *Stein manifold* is a complex submanifold M of \mathbb{C}^ν such that the natural inclusion $M \hookrightarrow \mathbb{C}^\nu$ is a proper map. Let m denote the *complex* dimension of M and denote by $\zeta = (\zeta^1, \dots, \zeta^\nu)$ the complex linear coordinates on \mathbb{C}^ν . We set $\mathbf{i} = \sqrt{-1}$.

Example 3.6. Suppose $M \subset \mathbb{C}^\nu$ is an affine algebraic submanifold of \mathbb{C}^ν , i.e. there exist polynomials $P_1, \dots, P_r \in \mathbb{C}[\zeta^1, \dots, \zeta^\nu]$ such that

$$M = \{ \zeta \in \mathbb{C}^\nu; P_i(\zeta) = 0, \forall i = 1, \dots, r \}.$$

Then M is a Stein manifold. □

Suppose $M \hookrightarrow \mathbb{C}^\nu$ is a Stein manifold. Modulo a translation of M we can assume that the function $f : \mathbb{C}^\nu \rightarrow \mathbb{R}$, $f(\zeta) = |\zeta|^2$ restricts to a Morse function which is necessarily exhaustive because M is properly embedded. The following theorem due to A. Andreotti and T. Frankel [AF] is the main result of this section.

Theorem 3.7. *The Morse indices of critical points of $f|_M$ are not greater than m .* □

Corollary 3.8. *A Stein manifold of complex dimension m has the homotopy type of an m -dimensional CW complex.¹ In particular,*

$$H_k(M, \mathbb{Z}) = 0, \quad \forall k > m. \quad \square$$

¹ With a bit of extra work one can prove that if X is affine *algebraic*, then f has only *finitely* many critical points, so X is homotopic to a compact CW complex. There exist, however, Stein manifolds for which f has infinitely many critical values.

Before we begin the proof of Theorem 3.7 we need to survey a few basic facts of complex differential geometry.

Suppose M is a complex manifold of complex dimension m . Then the (real) tangent bundle TM is equipped with a natural automorphism

$$J : TM \rightarrow TM$$

satisfying $J^2 = -1$ called the associated *almost complex structure*. If $(z^k)_{1 \leq k \leq m}$ are complex coordinates on M , $z^k = x^k + iy^k$, then

$$J\partial_{x^k} = \partial_{y^k}, \quad J\partial_{y^k} = -\partial_{x^k}.$$

We can extend J by complex linearity to the complexified tangent bundle ${}^cTM := TM \otimes_{\mathbb{R}} \mathbb{C}$, $J_c : {}^cTM \rightarrow {}^cTM$. The equality $J^2 = -1$ shows that $\pm i$ are the only eigenvalues of J_c . If we set

$$TM^{1,0} := \ker(\mathbf{i} - J_c), \quad TM^{0,1} := \ker(\mathbf{i} + J_c),$$

then we get a direct sum decomposition

$${}^cTM = TM^{1,0} \oplus TM^{0,1}.$$

Locally $TM^{1,0}$ is spanned by the vectors

$$\partial_{z^k} = \frac{1}{2}(\partial_{x^k} - \mathbf{i}\partial_{y^k}), \quad k = 1, \dots, m,$$

while $TM^{0,1}$ is spanned by

$$\partial_{\bar{z}^k} = \frac{1}{2}(\partial_{x^k} + \mathbf{i}\partial_{y^k}), \quad k = 1, \dots, m.$$

We denote by $\text{Vect}^c(M)$ the space of *smooth* sections of cTM , and by $\text{Vect}(M)$ the space of smooth sections of TM , i.e., *real* vector fields on M .

Given $V \in \text{Vect}(M)$ described in local coordinates by

$$V = \sum_k (a^k \partial_{x^k} + b^k \partial_{y^k}),$$

and if we set $v^k = a^k + \mathbf{i}b^k$, we obtain the (local) equalities

$$V = \sum_k (v^k \partial_{z^k} + \bar{v}^k \partial_{\bar{z}^k}), \quad JV = \sum_k (\mathbf{i}v^k \partial_{z^k} - \mathbf{i}\bar{v}^k \partial_{\bar{z}^k}). \quad (3.1)$$

The operator J induces an operator $J^t : T^*M \rightarrow T^*M$ that extends by complex linearity to ${}^cT^*M$. Again we have a direct sum decomposition

$${}^cT^*M = T^*M^{1,0} \oplus T^*M^{0,1},$$

$$T^*M^{1,0} = \ker(\mathbf{i} - J_c^t), \quad T^*M^{0,1} = \ker(\mathbf{i} + J_c^t).$$

Locally, $T^*M^{1,0}$ is spanned by $dz^k = dx^k + i dy^k$, while $T^*M^{0,1}$ is spanned by $d\bar{z}^k = dx^k - i dy^k$. The decomposition

$${}^cT^*M = T^*M^{1,0} \oplus T^*M^{0,1}$$

induces a decomposition of $\Lambda^r {}^cT^*M$,

$$\Lambda^r {}^cT^*M = \bigoplus_{p+q=r} \Lambda^{p,q}T^*M, \quad \Lambda^{p,q}T^*M = \Lambda^p T^*M^{1,0} \otimes_{\mathbb{C}} \Lambda^q T^*M^{0,1}.$$

The bundle $\Lambda^{p,q}T^*M$ is locally spanned by the forms $dz^I \wedge d\bar{z}^J$, where I, J are ordered multi-indices of length $|I| = p$, $|J| = q$,

$$I = (i_1 < i_2 < \cdots < i_p), \quad J = (j_1 < \cdots < j_q),$$

and

$$dz^I = dz^{i_1} \wedge \cdots \wedge dz^{i_p}, \quad d\bar{z}^J = d\bar{z}^{j_1} \wedge \cdots \wedge d\bar{z}^{j_q}.$$

We denote by $\Omega^{p,q}(M)$ the space of smooth sections of $\Lambda^{p,q}T^*M$ and by $\Omega^r(M, \mathbb{C})$ the space of smooth sections of $\Lambda^r {}^cT^*M$. The elements of $\Omega^{p,q}(M)$ are called (p, q) -forms.

The exterior derivative of a (p, q) -form α admits a decomposition

$$d\alpha = (d\alpha)^{p+1,q} + (d\alpha)^{p,q+1}.$$

We set

$$\partial\alpha := (d\alpha)^{p+1,q}, \quad \bar{\partial}\alpha := (d\alpha)^{p,q+1}.$$

If f is a $(0, 0)$ -form (i.e., a complex valued function on M), then locally we have

$$\partial f = \sum_k (\partial_{z^k} f) dz^k, \quad \bar{\partial} f = \sum_k (\partial_{\bar{z}^k} f) d\bar{z}^k.$$

In general, if

$$\alpha = \sum_{|I|=p, |J|=q} \alpha_{IJ} dz^I \wedge d\bar{z}^J, \quad \alpha_{IJ} \in \Omega^{0,0}$$

then

$$\partial\alpha = \sum_{|I|=p, |J|=q} \partial\alpha_{IJ} \wedge dz^I \wedge d\bar{z}^J, \quad \bar{\partial}\alpha = \sum_{|I|=p, |J|=q} \bar{\partial}\alpha_{IJ} \wedge dz^I \wedge d\bar{z}^J.$$

We deduce that for every $f \in \Omega^{0,0}(M)$ we have the local equality

$$\partial\bar{\partial}f = \sum_{j,k} \partial_{z^j} \partial_{\bar{z}^k} f dz^j \wedge d\bar{z}^k. \quad (3.2)$$

If $U = \sum_j (a^j \partial_{x^k} + b^j \partial_{y^j})$ and $V = \sum_k (c^k \partial_{x^k} + d^k \partial_{y^k})$ are locally defined real vector fields on M and we set

$$w^j = (a^j + \mathbf{i}b^j), \quad v^k = (c^k + \mathbf{i}d^k),$$

then using (3.2) we deduce

$$\partial\bar{\partial}f(U, V) = \sum_{j,k} (\partial_{z^j} \partial_{\bar{z}^k} f)(w^j \bar{v}^k - \bar{u}^k v^j). \quad (3.3)$$

Lemma 3.9. *Suppose $f : M \rightarrow \mathbb{R}$ is a smooth real valued function on the complex manifold M and p_0 is a critical point of f . Denote by H the Hessian of f at p_0 . We define the complex Hessian of f at p_0 to be the \mathbb{R} -bilinear map*

$$C_f : T_{p_0}M \times T_{p_0}M \rightarrow \mathbb{R},$$

$$C_f(U, V) := H(U, V) + H(JU, JV), \quad \forall U, V \in T_{p_0}M.$$

Then

$$C_f(U, V) = \mathbf{i}\partial\bar{\partial}f(U, JV).$$

Proof. Fix complex coordinates (z^1, \dots, z^m) near p_0 such that $z^j(p_0) = 0$. Set $f_0 = f(p_0)$. Near p_0 we have a Taylor expansion

$$f(z) = f_0 + \frac{1}{2} \sum_{j,k} (a_{jk} z^j z^k + b_{jk} \bar{z}^j \bar{z}^k + c_{jk} z^j \bar{z}^k) + \dots$$

Since f is real valued, we deduce

$$b_{jk} = \bar{a}_{jk}, \quad c_{jk} = \bar{c}_{kj} = (\partial_{z^j} \partial_{\bar{z}^k} f)(0).$$

Given real vectors

$$U = \sum_j (u^j \partial_{z^j} + \bar{u}^j \partial_{\bar{z}^j}) \in T_{p_0}M, \quad V = \sum_k (v^k \partial_{z^k} + \bar{v}^k \partial_{\bar{z}^k}),$$

we set $H(U) := H(U, U)$, and we have

$$H(U) = \sum_{j,k} (a_{jk} u^j u^k + b_{jk} \bar{u}^j \bar{u}^k + c_{jk} u^j \bar{u}^k).$$

Using the polarization formula

$$H(U, V) = \frac{1}{4} (H(U+V) - H(U-V))$$

we deduce

$$H(U, V) = \sum_{j,k} (a_{jk} u^j v^k + b_{jk} \bar{u}^j \bar{v}^k) + \frac{1}{2} \sum_{j,k} c_{jk} (u^j \bar{v}^k + \bar{u}^j v^k).$$

Using (3.1) we deduce

$$H(JU, JV) = - \sum_{j,k} (a_{jk} u^j v^k + b_{jk} \bar{u}^j \bar{v}^k) + \frac{1}{2} \sum_{j,k} c_{jk} (u^j \bar{v}^k + \bar{u}^j v^k),$$

so that

$$C_f(U, V) = H(U, V) + H(JU, JV) = \sum_{j,k} c_{jk} (u^j \bar{v}^k + \bar{u}^j v^k).$$

Using (3.1) again we conclude that

$$\begin{aligned} C(U, JV) &= \sum_{j,k} c_{jk} (-i u^j \bar{v}^k + i \bar{u}^j v^k) \\ &= -i \sum_{j,k} c_{jk} (u^j \bar{v}^k - \bar{u}^j v^k) \stackrel{(3.3)}{=} -i \partial \bar{\partial} f(U, V). \end{aligned}$$

Replacing V by $-JV$ in the above equality we obtain the desired conclusion. \square

Lemma 3.10 (Pseudoconvexity). *Consider the function*

$$f : \mathbb{C}^\nu \rightarrow \mathbb{R}, \quad f(\zeta) = \frac{1}{2} |\zeta|^2.$$

Then for every $q \in \mathbb{C}^\nu$ and every real tangent vector $U \in T_q \mathbb{C}^\nu$ we have

$$i(\partial \bar{\partial} f)_q(U, JU) = |U|^2.$$

Proof. We have

$$f = \frac{1}{2} \sum_k \zeta^k \bar{\zeta}^k, \quad \partial \bar{\partial} f = \frac{1}{2} \sum_k d\zeta^k \wedge d\bar{\zeta}^k.$$

If

$$U = \sum_k (u^k \partial_{\zeta^k} + \bar{u}^k \partial_{\bar{\zeta}^k}) \in T_q \mathbb{C}^\nu,$$

then

$$JU = i \sum_k (u^k \partial_{\zeta^k} - \bar{u}^k \partial_{\bar{\zeta}^k})$$

and

$$\begin{aligned}
 (\partial\bar{\partial}f)_{p_0}(U, JU) &= \frac{1}{2} \sum_k d\zeta^k \wedge d\bar{\zeta}^k(U, JU) \\
 &= \frac{1}{2} \sum_k \begin{vmatrix} d\zeta^k(U) & d\zeta^k(JU) \\ d\bar{\zeta}^k(U) & d\bar{\zeta}^k(JU) \end{vmatrix} \\
 &= \frac{1}{2} \sum_k \left(d\zeta^k(U)d\bar{\zeta}^k(JU) - d\zeta^k(JU)d\bar{\zeta}^k(U) \right) \\
 &= -i \sum_k u^k \bar{u}^k = -i|U|^2.
 \end{aligned}$$

□

Proof of Theorem 3.7 Let $M \hookrightarrow \mathbb{C}^\nu$ be a Stein manifold of complex dimension m and suppose $f : \mathbb{C}^\nu \rightarrow \mathbb{R}$, $f(\zeta) = \frac{1}{2}|\zeta|^2$ restricts to a Morse function on M . Suppose p_0 is a critical point of $f|_M$ and denote by H the Hessian of $f|_M$ at p_0 . We want to prove that $\lambda(f, p_0) \leq m$. Equivalently, we have to prove that if $S \subset T_{p_0}M$ is a real subspace such that the restriction of H to S is negative definite, then

$$\dim_{\mathbb{R}} S \leq m.$$

Denote by $J : TM \rightarrow TM$ the associated almost complex structure. We will first prove that $S \cap JS = 0$. We argue by contradiction.

Suppose $S \cap JS \neq 0$. Then there exists $U \in S \setminus 0$ such that $JU \in S$. Then

$$H(U, U) < 0, \quad H(JU, JU) < 0 \implies C_f(U, U) = H(U, U) + H(JU, JU) < 0.$$

Lemma 3.9 implies

$$0 > C_f(U, U) = i(\partial\bar{\partial}f|_M)_{p_0}(U, JU) = i(\partial\bar{\partial}f)_{p_0}(U, JU),$$

while the pseudoconvexity lemma implies

$$0 > i(\partial\bar{\partial}f)_{p_0}(U, JU) = |U|^2,$$

which is clearly impossible. Hence $S \cap JS = 0$ and we deduce

$$2m = \dim_{\mathbb{R}} T_{p_0}M \geq \dim_{\mathbb{R}} S + \dim_{\mathbb{R}} JS = 2 \dim_{\mathbb{R}} S. \quad \square$$

Let us discuss a classical application of Theorem 3.7. Suppose $V \subset \mathbb{C}\mathbb{P}^\nu$ is a smooth complex submanifold of complex dimension m described as the zero set of a finite collection of homogeneous polynomials²

$$Q_1, \dots, Q_r \in \mathbb{C}[z^0, \dots, z^\nu].$$

² By Chow's theorem, every complex submanifold of $\mathbb{C}\mathbb{P}^\nu$ can be described in this fashion [GH, I.3].

Consider a hyperplane $H \subset \mathbb{C}\mathbb{P}^n$. Modulo a linear change in coordinates we can assume that it is described by the equation $z^0 = 0$. Its complement can be identified with \mathbb{C}^ν with coordinates $\zeta_k = \frac{z^k}{z^0}$. Denote by M the complement of $V_\infty := V \cap H$ in V ,

$$M = V \setminus V_\infty.$$

Let us point out that V_∞ *need not be smooth*. Notice that M is a submanifold of \mathbb{C}^ν described as the zero set of the collection of polynomials

$$P_j(\zeta^1, \dots, \zeta^\nu) = Q_j(1, \zeta^1, \dots, \zeta^\nu),$$

and thus it is an affine algebraic submanifold of \mathbb{C}^ν . In particular, M is a Stein manifold. By Theorem 3.7 we deduce

$$H_{m+k}(M, \mathbb{Z}) = 0, \quad \forall k > 0.$$

On the other hand, we have the Poincaré–Lefschetz duality isomorphism [Spa, Theorem 6.2.19]³

$$H_j(V \setminus V_\infty, \mathbb{Z}) \rightarrow H^{2m-j}(V, V_\infty; \mathbb{Z}),$$

and we deduce

$$H^{m-k}(V, V_\infty; \mathbb{Z}) = 0, \quad \forall k > 0.$$

The long exact sequence cohomological sequence of the pair (V, V_∞) ,

$$\begin{aligned} \dots \rightarrow H^{m-k}(V, V_\infty; \mathbb{Z}) \rightarrow H^{m-k}(V, \mathbb{Z}) \rightarrow H^{m-k}(V_\infty; \mathbb{Z}) \xrightarrow{\delta} \\ \rightarrow H^{m-(k-1)}(V, V_\infty; \mathbb{Z}) \rightarrow \dots, \end{aligned}$$

implies that the natural morphism

$$H^{m-k}(V, \mathbb{Z}) \rightarrow H^{m-k}(V_\infty; \mathbb{Z})$$

is an isomorphism if $k > 1$, and it is an injection if $k = 1$. Note that

$$k > 1 \iff m - k < \frac{1}{2} \dim_{\mathbb{R}} V_\infty, \quad k = 1 \iff m - k = \frac{1}{2} \dim_{\mathbb{R}} V_\infty.$$

We have obtained the celebrated *Lefschetz hyperplane theorem*.

Theorem 3.11 (Lefschetz). *If V is a projective algebraic manifold and V_∞ is the intersection of V with a hyperplane, then the natural restriction morphism*

$$H^j(V, \mathbb{Z}) \rightarrow H^j(V_\infty, \mathbb{Z})$$

is an isomorphism for $j < \frac{1}{2} \dim_{\mathbb{R}} V_\infty$ and an injection for $j = \frac{1}{2} \dim_{\mathbb{R}} V_\infty$. \square

³ This duality isomorphism does not require V_∞ to be smooth. Only $V \setminus V_\infty$ needs to be smooth; V_∞ is automatically tautly embedded, since it is triangulable.

3.3 Symplectic Manifolds and Hamiltonian Flows

A *symplectic pairing* on a finite dimensional vector space V is, by definition, a nondegenerate skew-symmetric bilinear form ω on V . The nondegeneracy means that the induced linear map

$$I_\omega : V \rightarrow V^*, \quad v \mapsto \omega(v, \bullet),$$

is an isomorphism. We will identify a symplectic pairing with an element of A^2V^* called a *symplectic form*.

Suppose ω is a symplectic pairing on the vector space V . An *almost complex structure tamed* by ω is an \mathbb{R} -linear operator $J : V \rightarrow V$ such that $J^2 = -\mathbb{1}_V$ and the bilinear form

$$g = g_{\omega, J} : V \times V \rightarrow \mathbb{R}, \quad g(u, v) = \omega(u, Jv)$$

is symmetric and positive definite. We denote by \mathcal{J}_ω the space of almost complex structures tamed by ω .

Proposition 3.12. *Suppose ω is a symplectic pairing on the real vector space V . Then \mathcal{J}_ω is a nonempty contractible subset of $\text{End}(V)$. In particular, the dimension of V is even, $\dim V = 2n$, and for every $J \in \mathcal{J}_\omega$ there exists a $g_{\omega, J}$ -orthonormal basis $(e_1, f_1, \dots, e_n, f_n)$ of V such that*

$$Je_i = f_i, \quad Jf_i = -e_i, \quad \forall i \text{ and } \omega(u, v) = g(Ju, v), \forall u, v \in V.$$

We say that the basis (e_i, f_i) is adapted to ω .

Proof. Denote by \mathcal{M}_V the space of Euclidean metrics on V , i.e., the space of positive definite, symmetric bilinear forms on V . Then \mathcal{M}_V is a contractible space.

Any $h \in \mathcal{M}_V$ defines a linear isomorphism $A_h : V \rightarrow V$ uniquely determined by

$$\omega(u, v) = h(A_h u, v).$$

We say that h is *adapted* to ω if $A_h^2 = -\mathbb{1}_V$. We denote by \mathcal{M}_ω the space of metrics adapted to ω . We have thus produced a homeomorphism

$$\mathcal{M}_\omega \rightarrow \mathcal{J}_\omega, \quad h \mapsto A_h,$$

and it suffices to show that \mathcal{M}_ω is nonempty and contractible. More precisely, we will show that \mathcal{M}_ω is a retract of \mathcal{M}_V .

Fix a metric $h \in \mathcal{M}_V$. For every linear operator $B : V \rightarrow V$ we denote by B^* the adjoint of B with respect to h . Since ω is skew-symmetric, we have

$$A_h^* = -A_h.$$

Set $T_h = (A_h^* A_h)^{1/2} = (-A_h^2)^{1/2}$. Observe that A_h commutes with T_h . We define a new metric

$$\hat{h}(u, v) := h(T_h u, v) \iff h(u, v) = \hat{h}(T_h^{-1} u, v).$$

Then

$$\omega(u, v) = h(A_h u, v) = \hat{h}(T_h^{-1} A_h u, v) \implies A_{\hat{h}} = T_h^{-1} A_h.$$

We deduce that

$$A_{\hat{h}}^2 = T_h^{-2} A_h^2 = -\mathbb{1}_V,$$

so that $\hat{h} \in \mathcal{M}_\omega$ and therefore $\mathcal{M}_\omega \neq \emptyset$. Now observe that $\hat{h} = h \iff h \in \mathcal{M}_\omega$. This shows that the correspondence $h \mapsto \hat{h}$ is a retract of \mathcal{M}_V onto \mathcal{M}_ω . \square

If ω is a symplectic pairing on the vector space V and (e_i, f_i) is a basis of V adapted to ω , then

$$\omega = \sum_i e^i \wedge f^i,$$

where (e^i, f^i) denotes the dual basis of V^* . Observe that

$$\frac{1}{n!} \omega^n = e^1 \wedge f^1 \wedge \cdots \wedge e^n \wedge f^n.$$

Definition 3.13. (a) A symplectic structure on a smooth manifold M is a 2-form $\omega \in \Omega^2 T^*M$ satisfying

- $d\omega = 0$.
- For every $x \in M$ the element $\omega_x \in \Lambda^2 T_x^*M$ is a symplectic pairing on $T_x M$.

We will denote by $I_\omega : TM \rightarrow T^*M$ the bundle isomorphism defined by ω and we will refer to it as the symplectic duality.

(b) A symplectic manifold is a pair (M, ω) , where ω is a symplectic form on the smooth manifold M . A symplectomorphism of (M, ω) is a smooth map $f : M \rightarrow M$ such that

$$f^* \omega = \omega. \quad \square$$

Observe that if (M, ω) is a symplectic manifold, then M must be even dimensional, $\dim M = 2n$, and the form $dv_\omega := \frac{1}{n!} \omega^n$ is nowhere vanishing. We deduce that M is orientable. We will refer to dv_ω as the *symplectic volume form*, and we will refer to the orientation defined by dv_ω as the *symplectic orientation*. Note that if $f : M \rightarrow M$ is symplectomorphism then

$$f^*(dv_\omega) = dv_\omega.$$

In particular, f is a *local diffeomorphism*.

Example 3.14 (The standard model). Consider the vector space \mathbb{C}^n with Euclidean coordinates $z_j = x^j + iy^j$. Then

$$\Omega = \sum_{j=1}^n dx^j \wedge dy^j = \frac{i}{2} \sum_{j=1}^n dz_j \wedge d\bar{z}_j = -\mathbf{Im} \sum_j dz^j \otimes d\bar{z}^j$$

defines a symplectic structure on \mathbb{C}^n . We will refer to (\mathbb{C}^n, Ω) as the *standard model*.

Equivalently, the standard model is the pair $(\mathbb{R}^{2n}, \Omega)$, where Ω is as above. \square

Example 3.15 (The classical phase space). Suppose M is a smooth manifold. The *classical phase space*, denoted by $\Phi(M)$, is the total space of the cotangent bundle of M . The space $\Phi(M)$ is equipped with a canonical symplectic structure. To describe it denote by $\pi : \Phi(M) \rightarrow M$ the canonical projection. The differential of π is a bundle morphism

$$D\pi : T\Phi(M) \rightarrow \pi^*TM.$$

Since π is a submersion, we deduce that $D\pi$ is surjective. In particular, its dual

$$(D\pi)^t : \pi^*T^*M \rightarrow T^*\Phi(M)$$

is injective, and thus we can regard the pullback π^*T^*M of T^*M to $\Phi(M)$ as a subbundle of $T^*\Phi(M)$.

The pullback π^*T^*M is equipped with a tautological section θ defined as follows. If $x \in M$ and $v \in T_x^*M$, so that $(v, x) \in \Phi(M)$, then

$$\theta(v, x) = v \in T_x^*M = (\pi^*T^*M)_{(v, x)}.$$

Since π^*T^*M is a subbundle of $T^*\Phi(M)$, we can regard θ as a 1-form on T^*M . We will refer to it as the *tautological 1-form* on the classical phase space.

If we choose local coordinates (x^1, \dots, x^n) on M we obtain a local frame (dx^1, \dots, dx^n) of T^*M . Any point in $\varphi \in T^*M$ is described by the numbers $(\xi_1, \dots, \xi_n, x^1, \dots, x^n)$, where $x = (x^i)$ are the coordinates of $\pi(\varphi)$ and $\sum \xi_i dx^i$ describes the vector in $T_{\pi(\varphi)}^*M$ corresponding to φ . The tautological 1-form is described in the coordinates (ξ_i, x^j) by

$$\theta = \sum_i \xi_i dx^i.$$

Set $\omega = -d\theta$. Clearly ω is closed. Locally,

$$\omega = \sum_i dx^i \wedge d\xi_i,$$

and we deduce that ω defines a symplectic structure on $\Phi(M)$. The pair $(\Phi(M), \omega)$ is called the *classical symplectic phase space*.

Let us point out a confusing fact. Suppose M is oriented, and the orientation is described locally by the n -form $dx^1 \wedge \dots \wedge dx^n$. This orientation induces an orientation on T^*M , the *topologists orientation* \mathbf{or}_{top} described locally by the fiber-first convention

$$d\xi_1 \wedge \cdots \wedge d\xi_n \wedge dx^1 \wedge \cdots \wedge dx^n.$$

This can be different from the symplectic orientation $\mathbf{or}_{\text{symp}}$ defined by

$$dx^1 \wedge d\xi_1 \wedge \cdots \wedge dx^n \wedge d\xi_n.$$

This discrepancy is encoded in the equality

$$\mathbf{or}_{\text{top}} = (-1)^{n(n+1)/2} \mathbf{or}_{\text{symp}}. \quad \square$$

Example 3.16 (Kähler manifolds). Suppose M is a complex manifold. A Hermitian metric on M is then a Hermitian metric h on the complex vector bundle $TM^{1,0}$. At every point $x \in M$ the metric h defines a *complex valued* \mathbb{R} -bilinear map

$$h_x : T_x M^{1,0} \times T_x M^{1,0} \rightarrow \mathbb{C}$$

such that for $X, Y \in T_x M^{1,0}$ and $z \in \mathbb{C}$ we have

$$\begin{aligned} zh_x(X, Y) &= h_x(zX, Y) = h_x(X, \bar{z}Y), \\ h_x(Y, X) &= \overline{h_x(X, Y)}, \quad h_x(X, X) > 0, \quad \text{if } X \neq 0. \end{aligned}$$

We now have an isomorphism of *real* vector spaces $T_x M \rightarrow T_x M^{1,0}$ given by

$$T_x M \ni X \mapsto X^{1,0} = \frac{1}{2}(X - iJX) \in T_x M^{1,0},$$

where $J \in \text{End}(TM)$ denotes the almost complex structure determined by the complex structure. Now define

$$g_x, \omega_x : T_x M \times T_x M \rightarrow \mathbb{R}$$

by setting

$$g_x(X, Y) = \mathbf{Re} h_x(X^{1,0}, Y^{1,0}) \quad \text{and} \quad \omega_x(X, Y) = -\mathbf{Im} h_x(X^{1,0}, Y^{1,0}),$$

where g_x is symmetric and ω_x is skew-symmetric. Note that

$$\begin{aligned} \omega_x(X, JX) &= -\mathbf{Im} h_x(X^{1,0}, (JX)^{1,0}) \\ &= -\mathbf{Im} h_x(X^{1,0}, iX^{1,0}) = \mathbf{Re} h_x(X^{1,0}, X^{1,0}). \end{aligned}$$

Thus ω_x defines a symplectic pairing on $T_x M$, and the almost complex structure J is tamed by ω_x .

Conversely, if $\omega \in \Omega^2(M)$ is a nondegenerate 2-form tamed by the complex structure J , then we obtain a Hermitian metric on M .

A *Kähler manifold* is a complex Hermitian manifold (M, h) such that the associated 2-form $\omega_h = -\mathbf{Im} h$ is symplectic.

By definition, a Kähler manifold is symplectic. Moreover, any *complex* submanifold of a Kähler manifold has an induced symplectic structure.

For example, the Fubini–Study form on the complex projective space $\mathbb{C}\mathbb{P}^n$ defined in projective coordinates $\mathbf{z} = [z_0, z_1, \dots, z_n]$ by

$$\omega = i\partial\bar{\partial} \log |\mathbf{z}|^2, \quad |\mathbf{z}|^2 = \sum_{k=0}^n |z_k|^2,$$

is tamed by the complex structure, and thus $\mathbb{C}\mathbb{P}^n$ is a Kähler manifold. In particular, any complex submanifold of $\mathbb{C}\mathbb{P}^n$ has a symplectic structure. The complex submanifolds of $\mathbb{C}\mathbb{P}^n$ are precisely the projective algebraic manifolds, i.e., the submanifolds of $\mathbb{C}\mathbb{P}^n$ defined as the zero sets of a finite family of homogeneous polynomials in $n + 1$ complex variables. \square

Example 3.17 (Codajoint orbits). To understand this example we will need a few basic facts concerning *homogeneous spaces*. For proofs and more information we refer to [Helg, Chapter II].

A smooth *right* action of a Lie group G on the smooth manifold M is a smooth map

$$M \times G \rightarrow M, \quad G \times M \ni (x, g) \mapsto R_g(x) := x \cdot g$$

such that

$$R_{\mathbf{1}} = \mathbb{1}_M, \quad (x \cdot g) \cdot h = x \cdot (gh), \quad \forall x \in M, \quad g, h \in G.$$

The action is called *effective* if $R_g \neq \mathbb{1}_M, \forall g \in G \setminus \{\mathbf{1}\}$.

Suppose G is a compact Lie group and H is a subgroup of G that is closed as a subset of G . Then H carries a natural structure of a Lie group such that H is a closed submanifold of G . The space $H \backslash G$ of right cosets of H equipped with the quotient topology carries a natural structure of a smooth manifold. Moreover, the right action of G on $H \backslash G$ is smooth, transitive, and the stabilizer of each point is a closed subgroup of G conjugated to H .

Conversely, given a smooth and transitive right action of G on a smooth manifold M , then for every point $m_0 \in M$ there exists a G -equivariant diffeomorphism $M \rightarrow G_{m_0} \backslash G$, where G_{m_0} denotes the stabilizer of m_0 . Via this isomorphism the tangent space of M at m_0 is identified with the quotient $T_1G/T_1G_{m_0}$.

Suppose G is a compact connected Lie group. We denote by \mathcal{L}_G the Lie algebra of G , i.e., the vector space of left invariant vector fields on G . As a vector space it can be identified with the tangent space T_1G . The group G acts on itself by conjugation,

$$C_g : G \rightarrow G, \quad h \mapsto ghg^{-1}.$$

Note that $C_g(1) = 1$. Denote by Ad_g the differential of C_g at 1. Then Ad_g is a linear isomorphism $\text{Ad}_g : \mathcal{L}_G \rightarrow \mathcal{L}_G$. The induced group morphism

$$\text{Ad} : G \rightarrow \text{Aut}_{\mathbb{R}}(\mathcal{L}_G), \quad g \mapsto \text{Ad}_g,$$

is called the *adjoint representation* of G . Observe that $\text{Ad}_{gh}^* = \text{Ad}_h^* \circ \text{Ad}_g^*$, and thus we have a *right action* of G on \mathcal{L}_G^*

$$\mathcal{L}_G^* \times G \longrightarrow \mathcal{L}_G^*, \quad (\alpha, g) \mapsto \alpha \cdot g := \text{Ad}_g^* \alpha.$$

This is called the *coadjoint action* of G .

For every $X \in \mathcal{L}_G$ and $\alpha \in \mathcal{L}_G^*$ we set

$$X^\sharp(\alpha) := \left. \frac{d}{dt} \right|_{t=0} \text{Ad}_{e^{tX}}^* \alpha \in T_\alpha \mathcal{L}_G^* = \mathcal{L}_G^*.$$

More explicitly, we have

$$\langle X^\sharp(\alpha), Y \rangle = \langle \alpha, [X, Y] \rangle, \quad \forall Y \in \mathcal{L}_G, \quad (3.4)$$

where $\langle \bullet, \bullet \rangle$ is the natural pairing $\mathcal{L}_G^* \times \mathcal{L}_G \rightarrow \mathbb{R}$.

Indeed,

$$\langle X^\sharp(\alpha), Y \rangle = \left\langle \left. \frac{d}{dt} \right|_{t=0} \text{Ad}_{e^{tX}}^* (\alpha), Y \right\rangle = \left\langle \alpha, \left. \frac{d}{dt} \right|_{t=0} \text{Ad}_{e^{tX}} Y \right\rangle = \langle \alpha, [X, Y] \rangle.$$

For every $\alpha \in \mathcal{L}_G^*$ we denote by $\mathcal{O}_\alpha \subset \mathcal{L}_G^*$ the orbit of α under the coadjoint action of G , i.e.,

$$\mathcal{O}_\alpha := \{ \text{Ad}_g^*(\alpha); \quad g \in G \}.$$

The orbit \mathcal{O}_α is a compact subset of \mathcal{L}_G^* . Denote by G_α the *stabilizer* of α with respect to the coadjoint action,

$$G_\alpha := \{ g \in G; \quad \text{Ad}_g^*(\alpha) = \alpha \}.$$

The stabilizer G_α is a Lie subgroup of G , i.e., a subgroup such that the subset G_α is a closed submanifold of G . We denote by \mathcal{L}_α its Lie algebra. The obvious map

$$G \rightarrow \mathcal{O}_\alpha, \quad g \mapsto \text{Ad}_g^*(\alpha),$$

is continuous and surjective, and it induces a homeomorphism from the space $G_\alpha \backslash G$ of right cosets of G_α (equipped with the quotient topology) to \mathcal{O}_α given by

$$\Phi : G_\alpha \backslash G \ni G_\alpha \cdot g \mapsto \text{Ad}_g^*(\alpha) \in \mathcal{O}_\alpha.$$

For every $g \in G$ denote by $[g]$ the right coset $G_\alpha \cdot g$. The quotient $G_\alpha \backslash G$ is a smooth manifold, and the induced map

$$\Phi : G_\alpha \backslash G \rightarrow \mathcal{L}_G^*$$

is a smooth *immersion*, because the differential at the point $[1] \in G_\alpha \backslash G$ is injective. It follows that \mathcal{O}_α is a smooth submanifold of \mathcal{L}_G^* . In particular, the tangent space $T_\alpha \mathcal{O}_\alpha$ can be canonically identified with a subspace of \mathcal{L}_G^* .

Set

$$\mathcal{L}_\alpha^\perp := \{ \beta \in \mathcal{L}_G^*; \quad \langle \beta, X \rangle = 0, \quad \forall X \in \mathcal{L}_\alpha \}.$$

We claim that

$$T_\alpha \mathcal{O}_\alpha = \mathcal{L}_\alpha^\perp.$$

Indeed, let $\dot{\beta} \in T_\alpha \mathcal{O}_\alpha \subset \mathcal{L}_G^*$. This means that there exists $X = X_\beta \in \mathcal{L}_G$ such that

$$\dot{\beta} = \left. \frac{d}{dt} \right|_{t=0} \text{Ad}_{\exp(tX_\beta)}^* \alpha = X_\beta^\sharp(\alpha).$$

Using (3.4) we deduce that

$$\langle \dot{\beta}, Y \rangle = \langle \alpha, [X_\beta, Y] \rangle, \quad \forall Y \in \mathcal{L}_G.$$

On the other hand, α is G_α -invariant, so that

$$\begin{aligned} Z^\sharp(\alpha) &= 0, \quad \forall Z \in \mathcal{L}_\alpha \\ \stackrel{(3.4)}{\implies} \langle Z^\sharp(\alpha), X \rangle &= \langle \alpha, [Z, X] \rangle = 0, \quad \forall X \in \mathcal{L}_G, \quad \forall Z \in \mathcal{L}_\alpha. \end{aligned}$$

If we choose $X = X_\beta$ in the above equality, we deduce

$$\langle \dot{\beta}, Z \rangle = \langle \alpha, [X_\beta, Z] \rangle, \quad \forall Z \in \mathcal{L}_{G_\alpha} \implies \dot{\beta} \in \mathcal{L}_\alpha^\perp.$$

This shows that $T_\alpha \mathcal{O}_\alpha \subset \mathcal{L}_\alpha^\perp$. The dimension count

$$T_\alpha \mathcal{O}_\alpha = \dim \mathcal{O}_\alpha = \dim G_\alpha \backslash G = \dim \mathcal{L}_G - \dim \mathcal{L}_\alpha = \dim \mathcal{L}_\alpha^\perp$$

implies

$$T_\alpha \mathcal{O}_\alpha = \mathcal{L}_\alpha^\perp.$$

The differential of $\Phi : G_\alpha \backslash G \rightarrow \mathcal{O}_\alpha$ at [1] induces an isomorphism

$$\Phi_* : T_{[1]} G_\alpha \backslash G \rightarrow T_\alpha \mathcal{O}_\alpha$$

and thus a linear isomorphism

$$\Phi_* : T_{[1]} G_\alpha \backslash G = \mathcal{L} / \mathcal{L}_\alpha \longrightarrow \mathcal{L}_\alpha^\perp, \quad X \bmod \mathcal{L}_\alpha \mapsto X^\sharp(\alpha).$$

Observe that the vector space \mathcal{L}_α^\perp is naturally isomorphic to the dual of $\mathcal{L}_G / \mathcal{L}_\alpha$. The above isomorphism is then an isomorphism $(\mathcal{L}_\alpha^\perp)^* \rightarrow \mathcal{L}_\alpha^\perp$. We obtain a nondegenerate bilinear pairing

$$\omega_\alpha : \mathcal{L}_\alpha^\perp \times \mathcal{L}_\alpha^\perp \rightarrow \mathbb{R}, \quad \omega_\alpha(\dot{\beta}, \dot{\gamma}) = \langle \dot{\beta}, \Phi_*^{-1} \dot{\gamma} \rangle.$$

Equivalently, if we write

$$\dot{\beta} = X_\beta^\sharp(\alpha), \quad \dot{\gamma} = X_\gamma^\sharp(\alpha), \quad X_\beta, X_\gamma \in \mathcal{L}_G,$$

then

$$\omega_\alpha(\dot{\beta}, \dot{\gamma}) = \langle X_\beta^\sharp(\alpha), X_\gamma \rangle = \langle \alpha, [X_\beta, X_\gamma] \rangle. \quad (3.5)$$

Observe that ω_α is skew-symmetric, so that ω_α is a symplectic pairing. The group G_α acts on $T_\alpha \mathcal{O}_\alpha$ and ω_α is G_α -invariant. Since G acts transitively on

\mathcal{O}_α and ω_α is invariant with respect to the stabilizer of α , we deduce that ω_α extends to a G -invariant, nondegenerate 2-form $\omega \in \Omega^2(\mathcal{O}_\alpha)$. We want to prove that it is a symplectic form, i.e., $d\omega = 0$.

Observe that the differential $d\omega$ is also G -invariant and thus it suffices to show that

$$(d\omega)_\alpha = 0.$$

Let $Y_i = X_i^\sharp(\alpha) \in T_\alpha \mathcal{O}_\alpha$, $X_i \in \mathcal{L}_G$, $i = 1, 2, 3$. We have to prove that

$$(d\omega)_\alpha(Y_1, Y_2, Y_3) = 0.$$

We have the following identity [Ni, Section 3.2.1]

$$\begin{aligned} d\omega(X_1, Y_2, Y_3) &= Y_1\omega(Y_2, Y_3) - Y_2\omega(Y_3, Y_1) + Y_3\omega(Y_1, Y_2) \\ &\quad + \omega(Y_1, [Y_2, Y_3]) - \omega(Y_2, [Y_3, Y_1]) + \omega(Y_3, [Y_1, Y_2]). \end{aligned}$$

Since ω is G -invariant we deduce

$$\omega(Y_i, Y_j) = \text{const} \quad \forall i, j,$$

so the first row in the above equality vanishes. On the other hand, at α we have the equality

$$\begin{aligned} &\omega(Y_1, [Y_2, Y_3]) - \omega(Y_2, [Y_3, Y_1]) + \omega(Y_3, [Y_1, Y_2]) \\ &= \langle \alpha, [X_1, [X_2, X_3]] - [X_2, [X_3, X_2]] + [Y_3, [X_1, X_2]] \rangle. \end{aligned}$$

The last term is zero due to the Jacobi identity. This proves that ω is a symplectic form on \mathcal{O}_α .

Consider the special case $G = U(n)$. Its Lie algebra $\underline{u}(n)$ consists of skew-Hermitian $n \times n$ matrices and it is equipped with the Ad-invariant metric

$$(X, Y) = \mathbf{Re} \operatorname{tr}(XY^*).$$

This induces an isomorphism $\underline{u}(n)^* \rightarrow \underline{u}(n)$. The coadjoint action of $U(n)$ on $\underline{u}(n)^*$ is given by

$$\operatorname{Ad}_T^*(X) = T^*XT = T^{-1}XT, \quad \forall T \in U(n). \quad \forall X \in \underline{u}(n) \cong \underline{u}(n)^*.$$

Fix $S_0 \in \underline{u}(n)$. We can assume that S_0 has the diagonal form

$$S_0 = S_0(\boldsymbol{\lambda}) = \mathbf{i}\lambda_1 \mathbb{1}_{\mathbb{C}^{n_1}} \oplus \cdots \oplus \mathbf{i}\lambda_k \mathbb{1}_{\mathbb{C}^{n_k}}, \quad \lambda_j \in \mathbb{R},$$

with $n_1 + \cdots + n_k = n$ and the λ 's. The coadjoint orbit of S_0 consists of all the skew-Hermitian matrices with the same spectrum as S_0 , multiplicities included.

Consider a *flag* of subspaces of type $\boldsymbol{\nu} := (n_1, \dots, n_k)$, i.e. an increasing filtration \mathbb{F} of \mathbb{C}^n by complex subspaces

$$0 = V_0 \subset V_1 \subset \cdots \subset V_k = \mathbb{C}^n$$

such that $n_j = \dim_{\mathbb{C}} V_j/V_{j-1}$. Denote by $P_j = P_j(\mathbb{F})$ the orthogonal projection onto V_j . We can now form the skew-Hermitian operator

$$A_{\lambda}(\mathbb{F}) = \sum_j i\lambda_j(P_j - P_{j-1}).$$

Observe that the correspondence $\mathbb{F} \mapsto A_{\lambda}(\mathbb{F})$ is a bijection from the set of flags of type ν to the coadjoint orbit of $S_0(\lambda)$. We denote this set of flags by $\mathbf{Fl}_{\mathbb{C}}(\nu)$. The natural smooth structure on the coadjoint orbit induces a smooth structure on the set of flags. We will refer to this smooth manifold as the *flag manifold* of type $\nu := (n_1, \dots, n_k)$. Observe that

$$\mathbf{Fl}_{\mathbb{C}}(1, n-1) = \mathbb{C}\mathbb{P}^{n-1},$$

$$\mathbf{Fl}_{\mathbb{C}}(k, n-k) = G_k(\mathbb{C}^n) = \text{the Grassmannian of } k\text{-planes in } \mathbb{C}^n.$$

The diffeomorphism A_{λ} defines by pullback a $U(n)$ -invariant symplectic form on $\mathbf{Fl}_{\mathbb{C}}(\nu)$, *depending on λ* . However, since $U(n)$ acts transitively on the flag manifold, *this symplectic form is uniquely determined up to a multiplicative constant*. \square

Proposition 3.18. *Suppose (M, ω) is a symplectic manifold. We denote by $\mathcal{J}_{M, \omega}$ the set of almost complex structures on M tamed by ω , i.e., endomorphisms J of TM satisfying the following conditions*

- $J^2 = -\mathbb{1}_{TM}$.
- The bilinear form $g_{\omega, J}$ defined by

$$g(X, Y) = \omega(X, JY), \quad \forall X, Y \in \text{Vect}(M)$$

is a Riemannian metric on M .

Then the set $\mathcal{J}_{\omega, M}$ is nonempty and the corresponding set of metrics $\{g_{\omega, J}; J \in \mathcal{J}_{M, \omega}\}$ is a retract of the space of metrics on M .

Proof. This is a version of Proposition 3.12 for families of vector spaces with symplectic pairings. The proof of Proposition 3.12 extends word for word to this more general case. \square

Suppose (M, ω) is a symplectic manifold. Since ω is nondegenerate, we have a bundle isomorphism $I_{\omega} : TM \rightarrow T^*M$ defined by

$$\begin{aligned} \langle I_{\omega}X, Y \rangle &= \omega(X, Y) \iff \langle \alpha, Y \rangle = \omega(I_{\omega}^{-1}\alpha, Y), \\ \forall \alpha &\in \Omega^1(M), \quad \forall X, Y \in \text{Vect}(M). \end{aligned} \tag{3.6}$$

One can give an alternative description of the symplectic duality.

For every vector field X on M we denote by $X\lrcorner$ or i_X the *contraction* by X , i.e., the operation $X\lrcorner : \Omega^\bullet(M) \rightarrow \Omega^{\bullet-1}(M)$ defined by

$$\begin{aligned} (X\lrcorner\eta)(X_1, \dots, X_k) &= \eta(X, X_1, \dots, X_k), \\ \forall X_1, \dots, X_k \in \text{Vect}(M), \quad \eta &\in \Omega^{k+1}(M). \end{aligned}$$

Then

$$I_\omega = \lrcorner\omega \iff I_\omega X = X\lrcorner\omega, \quad \forall X \in \text{Vect}(M). \quad (3.7)$$

Indeed,

$$\langle I_\omega X, Y \rangle = \omega(X, Y) = (X\lrcorner\omega)(Y), \quad \forall Y \in \text{Vect}(M).$$

Lemma 3.19. *Suppose J is an almost complex structure tamed by ω . Denote by g the associated Riemannian metric and by $I_g : TM \rightarrow T^*M$ the metric duality isomorphism. Then*

$$I_\omega = I_g \circ J \iff I_\omega^{-1} = -J \circ I_g^{-1}. \quad (3.8)$$

Proof. Denote by $\langle \bullet, \bullet \rangle$ the natural pairing between T^*M and TM . For any $X, Y \in \text{Vect}(M)$ we have

$$\langle I_\omega X, Y \rangle = \omega(X, Y) = g(JX, Y) = \langle I_g(JX), Y \rangle$$

so that $I_\omega = I_g \circ J$. □

For every vector field X on M we denote by Φ_t^X the (local) flow it defines. We have the following result.

Proposition 3.20. *Suppose $X \in \text{Vect}(M)$. The following statements are equivalent:*

- (a) Φ_t^X is a symplectomorphism for all sufficiently small t .
- (b) The 1-form $I_\omega X$ is closed.

Proof. (a) is equivalent to $L_X\omega = 0$, where L_X denotes the Lie derivative along X . Using Cartan's formula $L_X = di_X + i_Xd$ and the fact that $d\omega = 0$ we deduce

$$L_X\omega = di_X\omega = d(I_\omega X).$$

Hence $L_X\omega = 0 \iff d(I_\omega X) = 0$. □

Definition 3.21. *For every smooth function $H : M \rightarrow \mathbb{R}$ we denote by $\nabla^\omega H$ the vector field*

$$\nabla^\omega H := I_\omega^{-1}(dH).$$

The vector field $\nabla^\omega H$ is called the Hamiltonian vector field associated with H , or the symplectic gradient of H . The function H is called the Hamiltonian of $\nabla^\omega H$. The flow generated by $\nabla^\omega H$ is called the Hamiltonian flow generated by H . □

Proposition 3.20 implies the following result.

Corollary 3.22. *A Hamiltonian flow on the symplectic manifold (M, ω) preserves the symplectic forms, and thus it is a one-parameter group of symplectomorphisms.*

Lemma 3.23. *Suppose (M, ω) is a symplectic manifold, J is an almost complex structure tamed by ω , and g is the associated metric. Then for every smooth function H on M we have*

$$\nabla^\omega H = -J\nabla^g H, \quad (3.9)$$

where $\nabla^g H$ denotes the gradient of H with respect to the metric g .

Proof. Using (3.8) we have

$$I_g \nabla^g H = dH = I_\omega \nabla^\omega H = I_g J \nabla^\omega H \implies J \nabla^\omega H = \nabla^g H. \quad \square$$

Example 3.24 (The harmonic oscillator). Consider the standard symplectic plane \mathbb{C} with coordinate $z = q + ip$ and symplectic form $\Omega = dq \wedge dp$. Let

$$H(p, q) = \frac{1}{2m} p^2 + \frac{k}{2} q^2, \quad k, m > 0.$$

The standard complex structure J given by

$$J\partial_q = \partial_p, \quad J\partial_p = -\partial_q$$

is tamed by Ω , and the associated metric is the canonical Euclidean metric $g = dp^2 + dq^2$. Then

$$\nabla^g H = \frac{p}{m} \partial_p + kq \partial_q, \quad \nabla^\Omega H = -J\nabla^g H = \frac{p}{m} \partial_q - kq \partial_p.$$

The flow lines of $\nabla^\Omega H$ are obtained by solving the *Hamilton equations*

$$\begin{cases} \dot{q} = \frac{p}{m} \\ \dot{p} = -kq \end{cases}, \quad p(0) = p_0, \quad q(0) = q_0.$$

Note that $m\ddot{q} = -kq$, which is precisely the Newton equation of a *harmonic oscillator* with elasticity constant k and mass m . Furthermore, $p = m\dot{q}$ is the *momentum* variable. The Hamiltonian H is the sum of the kinetic energy $\frac{1}{2m}p^2$ and the potential (elastic) energy $\frac{kq^2}{2}$. If we set⁴ $\omega := \sqrt{\frac{k}{m}}$, then we deduce

$$q(t) = q_0 \cos(\omega t) + \frac{p_0}{m\omega} \sin(\omega t), \quad p(t) = -q_0 m\omega \sin(\omega t) + p_0 \cos(\omega t).$$

⁴ The overuse of the letter ω in this example is justified only by the desire to stick with the physicists' traditional notation.

The period of the oscillation is $T = \frac{2\pi}{\omega}$. The total energy $H = \frac{1}{2m}p^2 + \frac{kq^2}{2}$ is conserved during the motion, so that all the trajectories of this flow are periodic and are contained in the level sets $H = \text{const}$, which are ellipses. The motion along these ellipses is *clockwise* and has constant angular velocity ω . For more on the physical origins of symplectic geometry we refer to the beautiful monograph [Ar]. \square

Definition 3.25. *Given two smooth functions f, g on a symplectic manifold (M, ω) we define the Poisson bracket of f and g to be the Lie derivative of g along the symplectic gradient vector field of f . We denote it by $\{f, g\}$, so that⁵*

$$\{f, g\} := L_{\nabla^\omega f} g. \quad \square$$

We have an immediate corollary of the definition.

Corollary 3.26. *The smooth function f on the symplectic manifold (M, ω) is conserved along the trajectories of the Hamiltonian flow generated by $H \in C^\infty(M)$ if and only if $\{H, f\} = 0$. \square*

Lemma 3.27. *If (M, ω) is a symplectic manifold and $f, g \in C^\infty(M)$ then*

$$\{f, g\} = -\omega(\nabla^\omega f, \nabla^\omega g), \quad \nabla^\omega \{f, g\} = [\nabla^\omega f, \nabla^\omega g]. \quad (3.10)$$

In particular, $\{f, g\} = -\{g, f\}$ and $\{f, f\} = 0$.

Proof. Set $X_f = \nabla^\omega f$, $X_g = \nabla^\omega g$. We have

$$\{f, g\} = dg(X_f) \stackrel{(3.6)}{=} \omega(I_\omega^{-1} dg, X_f) = -\omega(X_f, X_g).$$

For every smooth function u on M we set $X_u := \nabla^\omega u$. We have

$$X_{\{f, g\}}u = \{\{f, g\}, u\} = -\{u, \{f, g\}\} = -X_u\{f, g\} = X_u\omega(X_f, X_g).$$

Since $L_{X_u}\omega = 0$, we deduce

$$\begin{aligned} X_u\omega(X_f, X_g) &= \omega([X_u, X_f], X_g) + \omega(X_f, [X_u, X_g]) \\ &= -[X_u, X_f]g + [X_u, X_g]f = -X_uX_fg + X_fX_u g + X_uX_g f - X_gX_u f. \end{aligned}$$

The equality $\{f, g\} = -\{g, f\}$ is equivalent to $X_g f = -X_f g$, and we deduce

$$\begin{aligned} X_{\{f, g\}}u &= -X_uX_fg + X_fX_u g + X_uX_g f - X_gX_u f \\ &= -2X_uX_fg - X_fX_g u + X_gX_f u = 2X_{\{f, g\}}u - [X_f, X_g]u. \end{aligned}$$

⁵ **Warning:** The existing literature does not seem to be consistent on the right choice of sign for $\{f, g\}$. We refer to [McS, Remark 3.3] for more discussions on this issue.

Hence

$$X_{\{f,g\}}u = [X_f, X_g]u, \quad \forall u \in C^\infty(M) \iff X_{\{f,g\}} = [X_f, X_g]. \quad \square$$

Corollary 3.28 (Conservation of energy). *Suppose (M, ω) is a symplectic manifold and H is a smooth function. Then any trajectory of the Hamiltonian flow generated by H is contained in a level set $H = \text{const}$. In other words, H is conserved by the flow.*

Proof. Indeed, $\{H, H\} = 0$. \square

Corollary 3.29. *The Poisson bracket defines a Lie algebra structure on the vector space of smooth functions on a symplectic manifold. Moreover, the symplectic gradient map*

$$\nabla^\omega : C^\infty(M) \rightarrow \text{Vect}(M)$$

is a morphism of Lie algebras.

Proof. We have

$$\begin{aligned} \{\{f, g\}, h\} + \{g, \{f, h\}\} &= X_{\{f,g\}}h + X_g X_f h = [X_f, X_g]h + X_g X_f h \\ &= X_f X_g h = \{f, \{g, h\}\}. \end{aligned}$$

\square

Example 3.30 (The standard Poisson bracket). Consider the standard model (\mathbb{C}^n, Ω) with coordinates $z_j = q^j + ip_j$ and symplectic form $\Omega = \sum_j dq^j \wedge dp_j$. Then for every smooth function f on \mathbb{C}^n we have

$$\nabla^\Omega f = - \sum_j (\partial_{p_j} f) \partial_{q^j} + \sum_j (\partial_{q^j} f) \partial_{p_j},$$

so that

$$\{f, g\} = \sum_j \left((\partial_{q^j} f)(\partial_{p_j} g) - (\partial_{p_j} f)(\partial_{q^j} g) \right). \quad \square$$

Suppose we are given a smooth *right* action of a Lie group G on a symplectic manifold (M, ω) ,

$$M \times G \rightarrow M, \quad G \times M \ni (x, g) \mapsto R_g(x) := x \cdot g.$$

The action of G is called *symplectic* if $R_g^* \omega = \omega, \forall g \in G$.

Denote by \mathcal{L}_G the Lie algebra of G . Then for any $X \in \mathcal{L}_G$ we denote by $X^\flat \in \text{Vect}(M)$ the infinitesimal generator of the flow $\Phi_t^X(z) = z \cdot e^{tX}, z \in M, t \in \mathbb{R}$. We denote by $\langle \bullet, \bullet \rangle$ the natural pairing $\mathcal{L}_G^* \times \mathcal{L}_G \rightarrow \mathbb{R}$.

Definition 3.31. A Hamiltonian action of the Lie group G on the symplectic manifold (M, ω) is a smooth right symplectic action of G on M together with an \mathbb{R} -linear map

$$\xi : \mathcal{L}_G \rightarrow C^\infty(M), \quad \mathcal{L}_G \ni X \mapsto \xi_X \in C^\infty(M),$$

such that

$$\nabla^\omega \xi_X = X^\flat, \quad \{\xi_X, \xi_Y\} = \xi_{[X, Y]}, \quad \forall X, Y \in \mathcal{L}_G.$$

The induced map $\mu : M \rightarrow \mathcal{L}_G^*$ defined by

$$\langle \mu(x), X \rangle := \xi_X(x), \quad \forall x \in M, \quad X \in \mathcal{L}_G,$$

is called the moment map of the Hamiltonian action. □

Example 3.32 (The harmonic oscillator again). Consider the action of S^1 on $\mathbb{C} = \mathbb{R}^2$ given by

$$\mathbb{C} \times S^1 \ni (z, e^{i\theta}) \mapsto z * e^{i\theta} := e^{-i\theta} z.$$

Using the computations in Example 3.24 we deduce that this action is Hamiltonian with respect to the symplectic form $\Omega = dx \wedge dy = \frac{i}{2} dz \wedge d\bar{z}$. If we identify the Lie algebra of S^1 with the Euclidean line \mathbb{R} via the differential of the natural covering map $t \mapsto e^{it}$, then we can identify the dual of the Lie algebra with \mathbb{R} , and then the moment map of this action is $\mu(z) = \frac{1}{2}|z|^2$. □

Lemma 3.33. Suppose we have a Hamiltonian action

$$M \times G \rightarrow M, \quad (x, g) \mapsto x \cdot g,$$

of the compact connected Lie group G on the symplectic manifold (M, ω) . Denote by $\mu : M \rightarrow \mathcal{L}_G^*$ the moment map of this action. Then

$$\mu(x \cdot g) = \text{Ad}_g^* \mu(x), \quad \forall g \in G, \quad x \in M.$$

Proof. Set $\xi_X = \langle \mu, X \rangle$. Since G is compact and connected, it suffices to prove the identity for g of the form $g = e^{tX}$. Now observe that

$$(X^\flat \mu)(x) = \frac{d}{dt} \Big|_{t=0} \mu(x \cdot e^{tX}) \quad \text{and} \quad X^\sharp(\mu(x)) = \frac{d}{dt} \Big|_{t=0} \text{Ad}_{e^{tX}}^* \mu(x),$$

and we have to show that

$$(X^\flat \mu)(x) = X^\sharp(\mu(x)), \quad \forall X \in \mathcal{L}_G, \quad x \in M.$$

For every $Y \in \mathcal{L}_G$ we have

$$\begin{aligned} \frac{d}{dt} \Big|_{t=0} \langle \mu(x \cdot e^{tX}), Y \rangle &= X^\flat \cdot \langle \mu(x), Y \rangle = \{\xi_X, \xi_Y\} = \xi_{[X, Y]} \\ &= \langle \mu(x), [X, Y] \rangle \stackrel{(3.4)}{=} \langle X^\sharp(\mu(x)), Y \rangle. \end{aligned}$$

□

Example 3.34 (Coadjoint orbits again). Suppose G is a compact connected Lie group. Fix $\alpha \in \mathcal{L}_G^* \setminus \{0\}$ and denote by \mathcal{O}_α the coadjoint orbit of α . Denote by ω the natural symplectic structure on \mathcal{O}_α described by (3.5). We want to show that the natural right action of G on $(\mathcal{O}_\alpha, \omega)$ is Hamiltonian and that the moment map of this action $\mu : \mathcal{O}_\alpha \rightarrow \mathcal{L}_G^*$ is given by

$$\mathcal{O}_\alpha \ni \beta \mapsto -\beta \in \mathcal{L}_G^*.$$

Let $X \in \mathcal{L}_G$. Set $h = h_X : \mathcal{L}_G^* \rightarrow \mathbb{R}$, $h(\beta) = -\langle \beta, X \rangle$, where as usual $\langle \bullet, \bullet \rangle$ denotes the natural pairing $\mathcal{L}_G^* \times \mathcal{L}_G \rightarrow \mathbb{R}$. In this case $X^\sharp = X^\flat$. We want to prove that

$$X^\sharp = \nabla^\omega h_X, \quad (3.11)$$

that is, for all $\beta \in \mathcal{O}_\alpha$ and all $\dot{\beta} \in T_\beta \mathcal{O}_\alpha$ we have

$$\omega(X^\sharp, \dot{\beta}) = dh_X(\dot{\beta}).$$

We can find $Y \in \mathcal{L}_G$ such that $\dot{\beta} = Y^\sharp(\beta)$. Then using (3.5) we deduce

$$\omega(X^\sharp, \dot{\beta}) = \langle \beta, [X, Y] \rangle.$$

On the other hand,

$$dh_X(Y)|_\beta = \frac{d}{dt} \Big|_{t=0} \langle \text{Ad}_{e^{tY}}^* \beta, X \rangle = \frac{d}{dt} \Big|_{t=0} \langle \beta, \text{Ad}_{e^{tY}} X \rangle = -\langle \beta, [X, Y] \rangle.$$

This proves that X^\sharp is the hamiltonian vector field determined by h_X . Moreover,

$$\{h_X, h_Y\}|_\beta = -\omega(X^\sharp, Y^\sharp)|_\beta = -\langle \beta, [X^\sharp, Y^\sharp] \rangle = h_{[X, Y]}(\beta).$$

This proves that the natural right action of G on G_α is Hamiltonian with moment map $\mu(\beta) = -\beta$. \square

Proposition 3.35. *Suppose we are given a Hamiltonian action of the compact Lie group G on the symplectic manifold. Then there exists a G -invariant almost complex structure tamed by ω . We will say that J and its associated metric*

$$h(X, Y) = \omega(X, JY), \quad \forall X, Y \in \text{Vect}(M)$$

are G -tamed by ω .

Proof. Fix an invariant metric on G , denote by dV_g the associated volume form, and denote by $|G|$ the volume of G with respect to this volume form.

Note first that there exist G -invariant Riemannian metrics on M . To find such a metric, pick an arbitrary metric g on M and then form its G -average \hat{g} ,

$$\hat{g}(X, Y) := \frac{1}{|G|} \int_G u^* g(X, Y) dV_u, \quad \forall X, Y \in \text{Vect}(M).$$

By construction, \hat{g} is G -invariant. As in the proof of Proposition 3.12 Define $B = B_{\hat{g}} \in \text{End}(TM)$ by

$$\hat{g}(BX, Y) = \omega(X, Y), \quad \forall X, Y \in \text{Vect}(M).$$

Clearly B is G -invariant because ω is G -invariant. Now define a new G -invariant metric h on M by

$$h(X, Y) := \hat{g}((B^*B)^{1/2}X, Y), \quad \forall X, Y \in \text{Vect}(M).$$

Then h defines a skew-symmetric almost complex structure J on TM by

$$\omega(X, Y) = h(JX, Y), \quad \forall X, Y \in \text{Vect}(M).$$

By construction J is a G -invariant almost complex structure tamed by ω . \square

Example 3.36 (A special coadjoint orbit). Suppose (M, ω) is a compact oriented manifold with a Hamiltonian action of the compact Lie group G . Denote by $\mu : M \rightarrow \mathcal{L}_G^*$ the moment map of this action. If \mathbb{T} is a subtorus of G , then there is an induced Hamiltonian action of \mathbb{T} on M with moment map $\mu_{\mathbb{T}}$ obtained as the composition

$$M \xrightarrow{\mu} \mathcal{L}_G^* \twoheadrightarrow \mathfrak{t}^*,$$

where $\mathcal{L}_G^* \twoheadrightarrow \mathfrak{t}^*$ denotes the natural projection obtained by restricting to the subspace \mathfrak{t} a linear function on \mathcal{L}_G .

Consider the projective space $\mathbb{C}\mathbb{P}^n$. As we have seen, for every $\lambda \in \mathbb{R}^*$ we obtain a $U(n+1)$ -equivariant identification of $\mathbb{C}\mathbb{P}^n$ with a coadjoint orbit of $U(n+1)$ given by

$$\Psi_{\lambda} := \mathbb{C}\mathbb{P}^n \ni L \mapsto i\lambda P_L \in \underline{\mathfrak{u}}(n+1),$$

where P_L denotes the unitary projection onto the complex line L , and we have identified $\underline{\mathfrak{u}}(n+1)$ with its dual via the Ad-invariant metric

$$(X, Y) = \mathbf{Re} \, \text{tr}(XY^*), \quad X, Y \in \underline{\mathfrak{u}}(n+1).$$

We want to choose λ such that the natural complex structure on $\mathbb{C}\mathbb{P}^n$ is adapted to the symplectic structure $\Omega_{\lambda} = \Psi_{\lambda}^* \omega_{\lambda}$, where ω_{λ} is the natural symplectic structure on the coadjoint orbit $\mathcal{O}_{\lambda} := \Psi_{\lambda}(\mathbb{C}\mathbb{P}^n)$. Due to the $U(n+1)$ equivariance, it suffices to check this at $L_0 = [1, 0, \dots, 0]$.

Note that if $L = [z_0, \dots, z_n]$ then P_L is described by the Hermitian matrix $(p_{jk})_{0 \leq j, k \leq n}$, where

$$p_{jk} = \frac{1}{|\mathbf{z}|^2} z_j \bar{z}_k, \quad \forall 0 \leq j, k \leq n.$$

In particular, $P_{L_0} = \text{Diag}(1, 0, \dots, 0)$.

If $L_t := [1, tz_1, \dots, tz_n] \in \mathbb{C}\mathbb{P}^n$, then

$$\dot{P} = \frac{d}{dt}\Big|_{t=0} \Psi_\lambda(P_{L_t}) = \mathbf{i}\lambda \begin{bmatrix} 0 & \bar{z}_1 & \cdots & \bar{z}_n \\ z_1 & 0 & \cdots & 0 \\ \vdots & \vdots & \ddots & \vdots \\ z_n & 0 & \cdots & 0 \end{bmatrix}.$$

On the other hand, let $X = (x_{ij})_{0 \leq i, j \leq n} \in \underline{u}(n+1)$. Then $x_{ji} = -\bar{x}_{ij}$, $\forall i, j$ and X defines a tangent vector $X^\sharp \in T_{L_0} \mathcal{O}_\lambda$

$$X^\sharp := \mathbf{i}\lambda \frac{d}{dt}\Big|_{t=0} e^{-tX} P_{L_0} e^{tX} = -\mathbf{i}\lambda [P_{L_0}, X] = \mathbf{i}\lambda \begin{bmatrix} 0 & \bar{x}_{10} & \cdots & \bar{x}_{n0} \\ x_{10} & 0 & \cdots & 0 \\ \vdots & \vdots & \ddots & \vdots \\ x_{n0} & 0 & \cdots & 0 \end{bmatrix}.$$

These two computations show that if we identify X^\sharp with the column vector $(x_{10}, \dots, x_{n0})^t$, then the complex J structure on $T_{L_0} \mathbb{C}\mathbb{P}^n$ acts on X^\sharp via the usual multiplication by \mathbf{i} .

Given $X, Y \in \underline{u}(n+1)$ we deduce from (3.5) that at $L_0 \in \mathcal{O}_\lambda$ we have

$$\omega_\lambda(X^\sharp, Y^\sharp) = \mathbf{R} \operatorname{tr}(\mathbf{i}\lambda P_{L_0} \cdot [X, Y]^*) = \lambda \mathbf{Im}[X, Y]_{0,0}^*,$$

where $[X, Y]_{0,0}^*$ denotes the $(0,0)$ entry of the matrix $[X, Y]^* = [Y^*, X^*] = [Y, X] = -[X, Y]$. We have

$$[X, Y]_{0,0} = \sum_{k=0}^n (x_{0k} y_{k0} - y_{0,k} x_{k0}) = - \sum_{k=1}^n (\bar{x}_{k0} y_{k0} - x_{k0} \bar{y}_{k0}).$$

Then

$$\omega(X^\sharp, JX^\sharp) = 2\lambda \sum_k |x_{0k}|^2$$

Thus, if λ is *positive*, then Ω_λ is tamed by the canonical almost complex structure on $\mathbb{C}\mathbb{P}^n$. *In the sequel we will choose $\lambda = 1$.*

We thus have a Hamiltonian action of $U(n+1)$ on $(\mathbb{C}\mathbb{P}^n, \Omega_1)$. The moment map μ of this action is the opposite of the inclusion

$$\Psi_1 : \mathbb{C}\mathbb{P}^n \hookrightarrow \underline{u}(n+1), \quad L \mapsto \mathbf{i}P_L,$$

so that

$$\mu(L) = -\Psi_1(L) = -\mathbf{i}P_L.$$

The *right* action of $U(n+1)$ on $\mathbb{C}\mathbb{P}^n$ is described by

$$\mathbb{C}\mathbb{P}^n \times U(n+1) \ni (L, T) \longmapsto T^{-1}L$$

because $P_{T^{-1}L} = T^{-1}P_L T$.

Consider now the torus $\mathbb{T}^n \subset U(n+1)$ consisting of diagonal matrices of determinant equal to 1, i.e.,⁶ matrices of the form

$$A(\mathbf{t}) = \text{Diag}(e^{-i(t_1+\dots+t_n)}, e^{it_1}, \dots, e^{it_n}), \quad \mathbf{t} = (t_1, \dots, t_n) \in \mathbb{R}^n.$$

Its action on $\mathbb{C}\mathbb{P}^n$ is described in homogeneous coordinates by

$$[z_0, \dots, z_n]A(\mathbf{t}) = [e^{i(t_1+\dots+t_n)}z_0, e^{-it_1}z_1, \dots, e^{-it_n}z_n].$$

This action *is not effective* since the elements $\text{Diag}(\zeta^{-n}, \zeta, \dots, \zeta)$, $\zeta^{n+1} = 1$ act trivially. We will explain in the next section how to get rid of this minor inconvenience.

The Lie algebra $\mathfrak{t}^n \subset \mathfrak{u}(n+1)$ of this torus can be identified with the vector space of skew-Hermitian diagonal matrices with trace zero.

We can identify the Lie algebra of \mathbb{T}^n with its dual using the Ad-invariant metric on $\mathfrak{u}(n+1)$. Under this identification the moment map of the action of \mathbb{T}^n is the map $\hat{\mu}$ defined as the composition of the moment map

$$\mu : \mathbb{C}\mathbb{P}^n \rightarrow \mathfrak{u}(n+1)$$

with the orthogonal projection $\mathfrak{u}(n+1) \rightarrow \mathfrak{t}^n$. Since $\text{tr } P_L = \dim_{\mathbb{C}} L = 1$ we deduce

$$\hat{\mu}(L) = -\text{Diag}(iP_L) + \frac{i}{n+1} \mathbb{1}_{\mathbb{C}^{n+1}},$$

where $\text{Diag}(P_L)$ denotes the diagonal part of the matrix representing P_L . We deduce

$$\hat{\mu}([z_0, \dots, z_n]) = -\frac{i}{|\mathbf{z}|^2} \text{Diag}(|z_0|^2, \dots, |z_n|^2) + \frac{i}{n+1} \mathbb{1}_{\mathbb{C}^{n+1}}.$$

Thus the *opposite* action of \mathbb{T}^n given by

$$[z_0, \dots, z_n]A(\mathbf{t}) = [e^{-i(t_1+\dots+t_n)}z_0, e^{it_1}z_1, \dots, e^{it_n}z_n]$$

is also Hamiltonian, and the moment map is

$$\mu(L) = \frac{i}{|\mathbf{z}|^2} \text{Diag}(|z_0|^2, \dots, |z_n|^2) - \frac{i}{n+1} \mathbb{1}_{\mathbb{C}^{n+1}}.$$

We now identify the Lie algebra \mathfrak{t}^n with the vector space⁷

$$W := \left\{ \mathbf{w} = (w_0, \dots, w_n) \in \mathbb{R}^{n+1}; \sum_i w_i = 0 \right\}.$$

A vector $\mathbf{w} \in W$ defines the Hamiltonian flow on $\mathbb{C}\mathbb{P}^n$,

⁶ \mathbb{T}^n is a maximal torus for the subgroup $SU(n+1) \subset U(n+1)$.

⁷ In down-to-earth terms, we get rid of the useless factor i in the above formulæ.

$$e^{it} *_w [z_0, \dots, z_n] = [e^{iw_0 t} z_0, e^{iw_1 t} z_1, \dots, e^{iw_n t} z_n],$$

with the Hamiltonian function

$$\xi_{\mathbf{w}}([z_0, \dots, z_n]) = \frac{1}{|\mathbf{z}|^2} \sum_{j=0}^n w_j |z_j|^2.$$

The flow does not change if we add to $\xi_{\mathbf{w}}$ a constant

$$c = \frac{c}{|\mathbf{z}|^2} \sum_{j=1}^n |z_j|^2.$$

Thus the Hamiltonian flow generated by $\xi_{\mathbf{w}}$ is identical to the Hamiltonian flow generated by

$$f = \frac{1}{|\mathbf{z}|^2} \sum_{j=0}^n w'_j |z_j|^2, \quad w'_j = w_j + c.$$

Note that if we choose $w'_j = j$ (so that $c = \frac{n}{2}$), we obtain the perfect Morse function we discussed in Example 2.21. In the next two sections we will show that this “accident” is a manifestation of a more general phenomenon. \square

3.4 Morse Theory of Moment Maps

In this section we would like to investigate in greater detail the Hamiltonian actions of a torus

$$\mathbb{T}^\nu := \underbrace{S^1 \times \dots \times S^1}_\nu$$

on a compact symplectic manifold (M, ω) . As was observed by Atiyah in [A] the moment map of such an action generates many Morse–Bott functions. Following [A] we will then show that this fact alone imposes surprising constraints on the structure of the moment map. In the next section we will prove that these Morse–Bott functions are in fact *perfect*.

Theorem 3.37. *Suppose (M, ω) is a symplectic manifold equipped with a Hamiltonian action of the torus $\mathbb{T} = \mathbb{T}^\nu$. Let $\mu : M \rightarrow \mathfrak{t}^*$ be the moment map of this action, where \mathfrak{t} denotes the Lie algebra of \mathbb{T} . Then for every $X \in \mathfrak{t}$ the function*

$$\xi_X : M \rightarrow \mathbb{R}, \quad \xi_X(x) = \langle \mu(x), X \rangle$$

is a Morse–Bott function. The critical submanifolds are symplectic submanifolds of M , and all the Morse indices and coindices are even.

Proof. Fix an almost complex structure J and metric h on TM that are equivariantly tamed by ω .

For every subset $A \subset \mathbb{T}$ we denote by $\text{Fix}_A(M)$ the set of points in M fixed by all the elements in A , i.e.

$$\text{Fix}_A(M) = \{x \in M; x \cdot a = x, \forall a \in A\}.$$

Lemma 3.38. *Suppose G is a subgroup of \mathbb{T} . Denote by \bar{G} its closure. Then*

$$\text{Fix}_G(M) = \text{Fix}_{\bar{G}}(M)$$

is a union of \mathbb{T} -invariant symplectic submanifolds of M .

Proof. Clearly $\text{Fix}_G(M) = \text{Fix}_{\bar{G}}(M)$. Since \mathbb{T} is commutative, the set $\text{Fix}_G(M)$ is \mathbb{T} -invariant. Let $x \in \text{Fix}_G(M)$ and $g \in G \setminus \{1\}$. Denote by A_g the differential at x of the smooth map

$$M \ni y \mapsto y \cdot g \in M.$$

The map A_g is a unitary automorphism of the Hermitian space $(T_x M, h, J)$. Define

$$\text{Fix}_g(T_x M) := \ker(\mathbb{1} - A_g) \quad \text{and} \quad \text{Fix}_G(T_x M) = \bigcap_{g \in G} \text{Fix}_g(T_x M).$$

Consider the exponential map defined by the equivariantly tamed metric h ,

$$\exp_x : T_x M \rightarrow M.$$

Fix $r > 0$ such that \exp_x is a diffeomorphism from $\{v \in T_x M; |v|_h < r\}$ onto an open neighborhood of $x \in M$.

Since g is an isometry, it maps geodesics to geodesics and we deduce that $\forall v \in T_x M$ such that $|v|_h < r$ we have

$$(\exp_x(v)) \cdot g = \exp(A_g v).$$

Thus $\exp(v)$ is a fixed point of g if and only if v is a fixed point of A_g , i.e., $v \in \text{Fix}_g(T_x M)$. We deduce that the exponential map induces a homeomorphism from a neighborhood of the origin in the vector space $\text{Fix}_G(T_x M)$ to an open neighborhood of $x \in \text{Fix}_G(M)$. This proves that $\text{Fix}_G(M)$ is a submanifold of M and for every $x \in \text{Fix}_G(M)$ we have

$$T_x \text{Fix}_G(M) = \text{Fix}_G(T_x M).$$

The subspace $\text{Fix}_G(T_x M) \subset T_x M$ is J -invariant, which implies that $\text{Fix}_G(M)$ is a symplectic submanifold. \square

Let $X \in \mathfrak{t} \setminus \{0\}$ and denote by G_X the one parameter subgroup

$$G_X = \{ e^{tX} \in \mathbb{T}; t \in \mathbb{R} \}.$$

Its closure is a connected subgroup of \mathbb{T} , and thus it is a torus \mathbb{T}_X of positive dimension. Denote by \mathfrak{t}_X its Lie algebra. Consider the function

$$\xi_X(x) = \langle \mu(x), X \rangle, \quad x \in M.$$

Lemma 3.39. $\mathbf{Cr}_{\xi_X} = \mathbf{Fix}_{\mathbb{T}_X}(M)$.

Proof. Let $X^\flat = \nabla^\omega \xi_X$. From (3.9) we deduce

$$X^\flat = \nabla^\omega \xi_X = -J\nabla^h \xi_X.$$

This proves that $x \in \mathbf{Cr}_{\xi_X} \iff x \in \mathbf{Fix}_{G_X}(M)$. \square

We can now conclude the proof of Theorem 3.37. We have to show that the components of $\mathbf{Fix}_{\mathbb{T}_X}(M)$ are nondegenerate critical manifolds.

Let F be a connected component of $\mathbf{Fix}_{\mathbb{T}_X}(M)$ and pick $x \in F$. As in the proof of Lemma 3.38, for every $t \in \mathbb{R}$ we denote by $A_t : T_x M \rightarrow T_x M$ the differential at x of the smooth map

$$M \ni y \mapsto y \cdot e^{tX} =: \Phi_t^X(y) \in M.$$

Then A_t is a unitary operator and

$$\ker(\mathbb{1} - A_t) = T_x F, \quad \forall t \in \mathbb{R}.$$

We let

$$\dot{A} := \left. \frac{d}{dt} \right|_{t=0} A_t.$$

Then \dot{A} is a skew-hermitian endomorphism of $(T_x M, J)$, and we have

$$A_t := e^{t\dot{A}} \quad \text{and} \quad T_x F = \ker \dot{A}.$$

Observe that

$$\dot{A}u = [U, X^\flat]_x, \quad \forall u \in T_x M, \quad \forall U \in \mathbf{Vect}(M), \quad U(x) = u. \quad (3.12)$$

Indeed,

$$\dot{A}u = \left. \frac{d}{dt} \right|_{t=0} A_t u = \left. \frac{d}{dt} \right|_{t=0} \left((\Phi_t^X)_* U \right)_x = -(L_{X^\flat} U)_x = [U, X^\flat, U]_x.$$

Consider the Hessian H_x of ξ_X at x . For $U_1, U_2 \in \mathbf{Vect}(M)$ we set

$$u_i := U_i(x) \in T_x M,$$

and we have

$$H_x(u_1, u_2) = (U_1(U_2\xi_X))|_x.$$

On the other hand,

$$\begin{aligned} U_1(U_2\xi_X) &= U_1d\xi_X(U_2) = U_1\omega(X^\flat, U_2) \\ &= (L_{U_1}\omega)(X^\flat, U_2) + \omega([U_1, X^\flat], U_2) + \omega(X^\flat, [U_1, U_2]). \end{aligned}$$

At x we have

$$[U_1, X^\flat]_x = \dot{A}u_1, \quad X^\flat(x) = 0,$$

and we deduce

$$H_x(u_1, u_2) = \omega(\dot{A}u_1, u_2) = h(J\dot{A}u_1, u_2). \quad (3.13)$$

Now observe that $B = J\dot{A}$ is a symmetric endomorphism of T_xM which commutes with J . Moreover,

$$\ker B = \ker \dot{A} = T_xF.$$

Thus B induces a symmetric linear isomorphism $B : (T_xF)^\perp \rightarrow (T_xF)^\perp$. Since it commutes with J , all its eigenspaces are J -invariant and in particular even-dimensional. This proves that F is a nondegenerate critical submanifold of ξ_X , and its Morse index is even, thus completing the proof of Theorem 3.37. \square

Note the following corollary of the proof of Lemma 3.39.

Corollary 3.40. *Let $X \in \mathfrak{t}$. Then for every critical submanifold C of ξ_X and every $x \in C$ we have*

$$T_xC = \{ u \in T_xM; \exists U \in \text{Vect}(M), [X^\flat, U]_x = 0, U(x) = u \},$$

where $X^\flat = \nabla^\omega \xi_X$. \square

We want to present a remarkable consequence of the result we have just proved known as the *moment map convexity theorem*. For an alternative proof we refer to [GS].

Recall that a (right) action $X \times G \rightarrow X$, $(g, x) \mapsto R_g(x) = x \cdot g$ of a group G on a set X is called *effective* if $R_g \neq \mathbb{1}_X, \forall g \in G \setminus \{1\}$.

We have the following remarkable result of Atiyah [A] and Guillemin and Sternberg [GS] that generalizes an earlier result of Frankel [Fra].

Theorem 3.41 (Atiyah–Guillemin–Sternberg). *Suppose we are given a Hamiltonian action of the torus $\mathbb{T} = \mathbb{T}^\nu$ on the compact connected symplectic manifold (M, ω) . Denote by $\mu : M \rightarrow \mathfrak{t}^*$ the moment map of this action and by $\{C_\alpha; \alpha \in \mathcal{A}\}$ the components of the fixed point set $\text{Fix}_{\mathbb{T}}(M)$. Then the following hold.*

- (a) μ is constant on each component C_α .
 (b) If $\mu_\alpha \in \mathfrak{t}^*$ denotes the constant value of μ on C_α , then $\mu(M) \subset \mathfrak{t}^*$ is the convex hull of the finite set $\{\mu_\alpha; \alpha \in \mathcal{A}\} \subset \mathfrak{t}^*$.
 (c) If the action of the torus is effective, then $\mu(M)$ has nonempty interior.

Proof. For every $x \in M$ we denote by \mathbf{St}_x the stabilizer of x ,

$$\mathbf{St}_x := \{g \in \mathbb{T}; x \cdot g = x\}.$$

Then \mathbf{St}_x is a *closed* subgroup of \mathbb{T} . The connected component of $\mathbf{1} \in \mathbf{St}_x$ is a subtorus $\mathbb{T}_x \subset \mathbb{T}$. We denote by \mathfrak{t}_x its Lie algebra.

The differential of μ defines for every point $x \in M$ a linear map

$$\dot{\mu}_x : T_x M \rightarrow \mathfrak{t}^*.$$

We denote its transpose by $\dot{\mu}_x^*$. It is a linear map

$$\dot{\mu}_x^* : \mathfrak{t} \rightarrow T_x^* M.$$

Observe that for every $X \in \mathfrak{t}$ we have

$$\dot{\mu}_x^*(X) = (d\xi_X)_x, \quad \text{where } \xi_X = \langle \mu, X \rangle : M \rightarrow \mathbb{R}. \quad (3.14)$$

Lemma 3.42. *For every $x \in M$ we have $\ker \dot{\mu}_x^* = \mathfrak{t}_x$.*

Proof. From the equality (3.14) we deduce that $X \in \ker \dot{\mu}_x^*$ if and only if $d\langle \mu, X \rangle$ vanishes at x . Since X^\flat is the Hamiltonian vector field determined by $\langle \mu, X \rangle$, we deduce that

$$X \in \ker \dot{\mu}_x^* \iff X^\flat(x) = 0 \iff X \in T_{\mathbf{1}} \mathbf{St}_x = \mathfrak{t}_x. \quad \square$$

Lemma 3.42 shows that μ is constant on the connected components C_α of $\text{Fix}_{\mathbb{T}}(M)$ because (the transpose of) its differential is identically zero along the fixed point set.

There are finitely many components since these components are the critical submanifolds of a Morse–Bott function ξ_X , where $X \in \mathbb{T}$ is such that $\mathbb{T}_X = \mathbb{T}$.

To prove the convexity statement it suffices to prove that if all the points μ_α lie on the same side of an affine hyperplane in \mathfrak{t}^* , then any other point $\eta \in \mu(M)$ lies on the same side of that hyperplane.

Any hyperplane in \mathfrak{t}^* is determined by a vector $X \in \mathfrak{t} \setminus 0$, unique up to a multiplicative constant. Let $X \in \mathfrak{t} \setminus 0$ and set

$$c_X = \min \{ \mu_\alpha, X \}; \quad \alpha \in \mathcal{A}, \quad m_X = \min_{x \in X} \xi_X(x) = \min_{x \in M} \langle \mu(x), X \rangle.$$

We have to prove that $m_X = c_X$.

Clearly $m_X \leq c_X$. To prove the opposite inequality observe that m_X is a critical value of ξ_X . Since ξ_X is a Morse–Bott function we deduce that its lowest level set

$$\{x \in M; \xi_X(x) = m_X\}$$

is a union of critical submanifolds. Pick one such critical submanifold C .

If we could prove that $C \cap \text{Fix}_{\mathbb{T}}(M) \neq \emptyset$, then we could conclude that $C_\alpha \subset C$ for some α and thus $c_X \leq m_X$.

The submanifold C is a connected component of $\text{Fix}_{\mathbb{T}_X}(M)$. It is a symplectic submanifold of M , and the torus $\mathbb{T}_\perp := \mathbb{T}/\mathbb{T}_X$ acts on C . Moreover,

$$\text{Fix}_{\mathbb{T}_\perp}(C) = C \cap \text{Fix}_{\mathbb{T}}(M),$$

so it suffices to show that

$$\text{Fix}_{\mathbb{T}_\perp}(C) \neq \emptyset.$$

Denote by \mathfrak{t}_\perp the Lie algebra of \mathbb{T}_\perp and by \mathfrak{t}_X the Lie algebra of \mathbb{T}_X . Observe that \mathfrak{t}_\perp^* is naturally a subspace of \mathfrak{t}^* ,

$$\mathfrak{t}_\perp^* = \mathfrak{t}_X^\perp := \{ \nu \in \mathfrak{t}^*; \langle \nu, Y \rangle = 0, \forall Y \in \mathfrak{t}_X \}.$$

Lemma 3.42 shows that for every $Y \in \mathfrak{t}_X$ the restriction of $\langle \mu, Y \rangle$ to C is a constant $\varphi(Y)$ depending linearly on Y . In other words, it is an element $\varphi \in \mathfrak{t}_X^*$. Choose a linear extension $\tilde{\varphi} : \mathfrak{t} \rightarrow \mathbb{R}$ of φ and set

$$\mu^\perp := \mu|_C - \tilde{\varphi}.$$

Observe that for every $Y \in \mathfrak{t}_X$ we have $\langle \mu^\perp, Y \rangle = 0$, and thus μ^\perp is valued in $\mathfrak{t}_X^\perp = \mathfrak{t}_\perp^*$. For every $Z \in \mathfrak{t}$ we have (along C)

$$\nabla^\omega \langle \mu, Z \rangle = \nabla^\omega \langle \mu^\perp, Z \rangle,$$

and we deduce that the action of \mathbb{T}_\perp on C is Hamiltonian with μ^\perp as moment map.

Choose now a vector $Z \in \mathfrak{t}_\perp$ such that the one-parameter group e^{tZ} is dense in \mathbb{T}_\perp . Lemma 3.39 shows that the union of the critical submanifolds of the Morse–Bott function $\xi_Z^\perp = \langle \mu^\perp, Z \rangle$ on C is fixed point set of \mathbb{T}_\perp . In particular, a critical submanifold corresponding to the minimum value of ξ_Z^\perp is a connected component of $\text{Fix}_{\mathbb{T}_\perp}(C)$. This proves the convexity statement.

Note one consequence of the above argument.

Corollary 3.43. *For every $X \in \mathbb{T}$ the critical values of ξ_X are*

$$\{ \langle \mu_\alpha, X \rangle; \alpha \in \mathcal{A} \} = \left\langle \mu(\text{Fix}_{\mathbb{T}}(M)), X \right\rangle.$$

Proof. If M_X is a critical submanifold of X , then the above proof shows that it must contain at least one of the C_α 's. Conversely, every C_α lies in the critical set of ξ_X . \square

To prove that $\mu(M)$ has nonempty interior if the action of \mathbb{T} is effective we use the following result.

Lemma 3.44. *The set of points $x \in M$ such that $\mu_x : T_x M \rightarrow \mathfrak{t}^*$ is surjective, open, and dense in M .*

Proof. Recall that an *integral weight* of \mathbb{T} is a vector $w \in \mathfrak{t}$ such that

$$e^{2\pi w} = 1 \in \mathbb{T}.$$

The integral weights define a lattice $L_{\mathbb{T}} \subset \mathfrak{t}$. This means that L is a discrete Abelian subgroup of \mathfrak{t} of rank equal to $\dim_{\mathbb{R}} \mathfrak{t}$. Observe that we have a natural isomorphism of Abelian groups

$$L_{\mathbb{T}} \rightarrow \text{Hom}(S^1, \mathbb{T}), \quad L_{\mathbb{T}} \ni w \mapsto \varphi_w \in \text{Hom}(S^1, \mathbb{T}), \quad \varphi_w(e^{it}) = e^{tw}.$$

Any primitive⁸ sublattice L' of $L_{\mathbb{T}}$ determines a closed subtorus $\mathbb{T}_{L'} := \{e^{tw}; w \in L'\}$, and any closed subtorus is determined in this fashion. This shows that there are at most countably many closed subtori of \mathbb{T} .

If $\mathbb{T}' \subset \mathbb{T}$ is a nontrivial closed subtorus, then it acts effectively on M , and thus its fixed point set is a closed proper subset of M . Baire's theorem then implies that

$$Z := M \setminus \bigcup_{\{1\} \neq \mathbb{T}' \subset \mathbb{T}} \text{Fix}_{\mathbb{T}'}(M) = \{z \in M; \mathfrak{t}_z = 0\}$$

is a dense subset of M . Lemma 3.42 shows that for any $z \in Z$ the map $\mu_z^* : \mathfrak{t} \rightarrow T_z^* M$ is one-to-one, or equivalently that μ_z is onto. The lemma now follows from the fact that the submersiveness is an open condition. \square

The image of the moment map contains a lot of information about the action.

Theorem 3.45. *Let (M, ω) , μ and \mathbb{T} be as above. Assume that \mathbb{T} acts effectively. For any face F of the polyhedron $\mu(M)$ we set*

$$F^\perp := \{X \in \mathfrak{t}; \exists c \in \mathbb{R} : \langle \eta, X \rangle = c, \forall \eta \in F\}.$$

Observe that F^\perp is a vector subspace of \mathfrak{t} whose dimension equals the codimension of F . It is called the conormal space of the face F . Then the following hold.

(a) *For any face F of the convex polyhedron $\mu(M)$ of positive codimension k the closed set*

$$M_F := \mu^{-1}(F)$$

is a connected symplectic submanifold of M of codimension $2k$, i.e.,

$$\text{codim } M_F = 2\text{codim } F.$$

Moreover, if we set

⁸ The sublattice $L' \subset L$ is called primitive if L/L' is a free Abelian group.

$$\mathbf{St}_F := \{g \in \mathbb{T}; x \cdot g = x, \forall x \in M_F\},$$

then

$$T_1\mathbf{St}_F = F^\perp$$

and thus the identity component of \mathbf{St}_F is a torus \mathbb{T}_F of dimension k . In particular, if F is a zero dimensional face, we deduce that

$$2 \dim \mathfrak{t}^* = \text{codim } M_F \leq \dim M.$$

(b) Conversely, for any nontrivial subtorus \mathbb{T}' of \mathbb{T} and any connected component C of the fixed point set $\text{Fix}_{\mathbb{T}'}(M)$ there exists a face F of $\mu(M)$ such that $C = M_F$. Moreover, $\mathbb{T}' \subset \mathbb{T}_F$.

Proof. A key ingredient in the proof is the following topological result.

Lemma 3.46 (Connectivity lemma). *Suppose $f : M \rightarrow \mathbb{R}$ is a Morse–Bott function on the compact connected manifold M such that Morse index and coindex of any critical submanifold are not equal to 1. Then for every $c \in \mathbb{R}$ the level set $\{f = c\}$ is connected or empty.*

To keep the flow of arguments uninterrupted we will present the proof of this result after we have completed the proof of the theorem.

Suppose F is a proper face of $\mu(M)$ of codimension $k > 0$. Then there exists $X \in \mathbb{T}$ which defines a proper supporting hyperplane for the face F , i.e.,

$$\langle \eta, X \rangle \leq \langle \eta', X \rangle, \quad \forall \eta \in F, \quad \eta' \in \mu(M),$$

with equality if and only if $\eta' \in F$. Consider then the Morse–Bott function $\xi_X = \langle \mu, X \rangle$ and denote by m_X its minimum value on M . Then

$$M_F = \mu^{-1}(F) = \{\xi_X = m_X\}.$$

Lemma 3.46 shows that M_F is connected. It is clearly included in the critical set of ξ_X , so that M_F is a critical submanifold of ξ_X . It is thus a component of the fixed point set of \mathbb{T}_X .

Form the torus $\mathbb{T}_\perp := \mathbb{T}/\mathbf{St}_F$ and denote by \mathfrak{t}_\perp its Lie algebra. Note that

$$\mathfrak{t}_\perp = \mathfrak{t}/\mathfrak{t}_F.$$

The dual of the Lie algebra \mathfrak{t}_\perp can be identified with a subspace of \mathfrak{t}^* ,

$$\mathfrak{t}_\perp^* = \mathfrak{t}_F^\perp = \{\eta \in \mathfrak{t}^*; \langle \eta, \mathfrak{t}_F \rangle = 0\} \subset \mathfrak{t}^*.$$

As in the proof of Theorem 3.41 we deduce that for every $X \in \mathfrak{t}_F$ the function $\langle \mu, X \rangle$ is constant along M_F . The action of \mathbb{T}_\perp on M_F is Hamiltonian, and as moment map we can take

$$\mu^\perp = \mu|_{M_F} - \varphi,$$

where φ is an arbitrary element in \mathfrak{t}^* satisfying

$$\langle \varphi, X \rangle = \langle \mu(z), X \rangle, \quad \forall z \in M_F, \quad X \in \mathfrak{t}_F.$$

Then

$$\mu^\perp(M_F) = F - \varphi \subset \mathfrak{t}_F^\perp = \mathfrak{t}_\perp^*.$$

Since the action of \mathbb{T}^\perp on M_F is effective, we deduce that the relative interior of $\mu^\perp(M_F)$ is open. Thus, the relative interior of $F - \varphi$ as a subset of $\mathfrak{t}_F^\perp \subset \mathfrak{t}^*$ is nonempty, and by duality we deduce that

$$F^\perp = (\mathfrak{t}_F^\perp)^\perp = \mathfrak{t}_F.$$

This proves that \mathbb{T}_F is a torus of the same dimension as F^\perp , which is the codimension of F .

Let us prove that

$$\text{codim } M_F = 2\text{codim } F = 2 \dim F^\perp.$$

Since the action of \mathbb{T} is effective, we deduce that the action of \mathbb{T}/St_F on M_F is effective. Using Lemmas 3.44 and 3.42 we deduce that there exists a point $z \in M_F$ such that its stabilizer with respect to the \mathbb{T}/St_F -action is finite. This means that the stabilizer of z with respect to the \mathbb{T} -action is a closed subgroup whose identity component is \mathbb{T}_F , i.e., $\mathfrak{t}_z = \mathfrak{t}_F$.

We set $V_z := T_z M_F$ and we denote by E_z the orthogonal complement of V_z in $T_z M$ with respect to a metric h on M equivariantly adapted to the Hamiltonian action as in the proof of Theorem 3.37. Then E_z is a complex Hermitian vector space. Let $m := \dim_{\mathbb{C}} E_z$, so that $2m = \text{codim}_{\mathbb{R}} M_F$.

We will prove that

$$m = \dim F^\perp = \dim \mathbb{T}_F.$$

The torus \mathbb{T}_F acts unitarily on E_z , and thus we have a morphism

$$\mathbb{T}_F \ni g \rightarrow A_g \in U(m) = \text{Aut}(E_z, h).$$

We claim that its differential

$$\mathfrak{t}_F \ni X \rightarrow \dot{A}_X = \left. \frac{d}{dt} \right|_{t=0} A_{e^{tX}} \in \underline{u}(m) = T_1 U(m)$$

is injective.

Indeed, let $X \in \mathfrak{t}_F \setminus 0$. Then z is a critical point of ξ_X . Denote by H_z the Hessian of ξ_Z at z . Arguing exactly as in the proof of (3.13) we deduce

$$H_z(u_1, u_2) = \omega(\dot{A}_X u_1, u_2) = h(J \dot{A}_X u_1, u_2), \quad \forall u_1, u_2 \in E_z.$$

Since ξ_X is a nonconstant Morse–Bott function, we deduce that $H_z|_{E_z} \neq 0$, and thus $\dot{A}_X \neq 0$. This proves the claim.

Thus the image $\hat{\mathbb{T}}_F$ of \mathbb{T}_F in $U(m)$ is a torus of the same dimension as \mathbb{T}_F , and since the maximal tori of $U(m)$ have dimension m we deduce

$$\text{codim } F = \dim \mathbb{T}_F \leq m = \frac{1}{2} \text{codim}_{\mathbb{R}}(M_F).$$

If $k = \dim \mathbb{T}_F < m$, then $\hat{\mathbb{T}}_F$ can be included in a maximal torus \mathbb{T}^m of $U(m)$ which has strictly larger dimension.

We can now choose a unitary basis e_1, \dots, e_m of E_z such that $\hat{\mathbb{T}}_F$ acts trivially on all the vectors e_j , $j > k$. Then for $t > 0$ sufficiently small and $j > k$ the points $\exp_z(te_j) \in M$ are fixed by \mathbb{T}_F . These points should therefore belong to the path component of $\text{Fix}_{\mathbb{T}_F}(M)$ containing z .

On the other hand, the path component of $\text{Fix}_{\mathbb{T}_F}(M)$ containing z is M_F . Indeed, if $X \in \mathbb{T}_F$ defines a proper supporting hyperplane for the face F . If we set $G_X = \{e^{tX}; t \in \mathbb{R}\}$, then $\text{Fix}_{G_X}(M) \supset \text{Fix}_{\mathbb{T}_F}(M)$. The connected components of $\text{Fix}_{G_X}(M)$ are the critical submanifolds of $\xi_X = \langle \mu, X \rangle$ and one of them is M_F .

We have now reached a contradiction, since the geodesics $\exp_z(te_j)$, $j > k$ are perpendicular to M_F at z . Hence

$$k = \dim \mathbb{T}_F = m = \frac{1}{2} \text{codim}(M_F).$$

This proves (a).

Let us prove (b). Consider a nontrivial subtorus \mathbb{T}' and a connected component C of $\text{Fix}_{\mathbb{T}'}(M)$. Set

$$\mathbf{St}_C := \{g \in \mathbb{T}; x \cdot g = x, \forall x \in C\}$$

and denote by \mathbb{T}_C the identity component of \mathbf{St}_C . Then C is a critical submanifold of ξ_X for any vector $X \in \mathfrak{t}$ such that $\mathbb{T}_X = \mathbb{T}_C$. We have to prove that there exists a face F of $\mu(M)$ such that $C = M_F$.

Lemma 3.47. *There exists $X \in \mathfrak{t}$ such that $\mathbb{T}_X = \mathbb{T}_C$ and such that C consists of the local minima of ξ_X .*

Assume the validity of the lemma. The linear function

$$\ell_X : \mathfrak{t}^* \ni \eta \mapsto \langle \eta, X \rangle \in \mathbb{R}$$

has a unique local minimum on the convex polyhedron $\mu(M)$, which is achieved exactly along a face F of $\mu(M)$. This local minimum must therefore be a global minimum. This proves two things.

- The submanifold C consists of global minimum points of ξ_X since $\mu(C) \subset \mu(M)$ consists of local minima of ℓ_X .
- The set of global minimum points of ξ_X is M_F . Indeed, x is a global minimum of ξ_X if and only if $\mu(x)$ is a global minimum of ℓ_X .

On the other hand, the connectivity lemma (Lemma 3.46) shows that the set of global minima of ξ_X is a critical submanifold of ξ_X . Since C is also a

critical submanifold of ξ_X , we deduce that $C = M_F$, because by definition, the critical submanifolds are connected.

Proof of Lemma 3.47. Choose a point $z \in C$ such that $\mathfrak{t}_z = \mathfrak{t}_C$. We denote by E_z the orthogonal complement of $T_z C$ in $T_z M$ with respect to a metric h adapted to the Hamiltonian action. As in the proof of (a) we obtain an immersive morphism

$$\mathbb{T}_C \rightarrow \text{Aut}(E_z, h), \quad g \mapsto A_g.$$

For every $X \in \mathbb{T}$ we set

$$\dot{A}_X u := \left. \frac{d}{dt} \right|_{t=0} A_{e^{tX}} u, \quad \forall u \in E_z.$$

The Hessian H_z of ξ_X at z satisfies the equality (3.13), so that

$$H_z(u_1, u_2) = h(J\dot{A}_X u_1, u_2).$$

If $\mathbb{T}_X = \mathbb{T}_C$ then H_z is nondegenerate along E_z , and from the equality

$$\bigcap_{g \in \mathbb{T}_C} \ker(\mathbb{1} - A_g) = 0$$

we deduce as in the proof of (a) that

$$\dim_{\mathbb{R}} \mathbb{T}_C = \dim_{\mathbb{C}} E_z.$$

In particular, this means that the image $\hat{\mathbb{T}}_C$ of \mathbb{T}_C in $\text{Aut}(E_z, h)$ is a maximal torus of $\text{Aut}(E_z, h)$.

The eigenvalues of \dot{A}_X are purely imaginary, and $\lambda \in \mathbb{R}$ is an eigenvalue of H_z if and only if $-i\lambda$ is an eigenvalue of \dot{A}_X . Now choose X such that

- the eigenvalues of \dot{A}_X have negative imaginary part and
- $\mathbb{T}_X = \mathbb{T}_C$, i.e., the eigenvalues of \dot{A}_X are linearly independent over \mathbb{Q} .

Then the Hessian H_z is positive definite along E_z . This proves that C is a strict local minimum of ξ_X . \square

To complete the proof of Theorem 3.45 we need to prove the connectivity Lemma 3.46.

Proof of Lemma 3.46. For $c_1 < c_2$ we set

$$M_{c_1}^{c_2} = \{c_1 \leq f \leq c_2\}, \quad M^{c_2} = \{f \leq c_2\}, \quad M_{c_1} = \{f \geq c_1\}, \quad L_{c_1} = \{f = c_1\}.$$

For any critical submanifold S of f we denote by E_S^+ (respectively E_S^-) the stable (respectively unstable) part of the normal bundle of S spanned by eigenvectors of the Hessian corresponding to positive/negative eigenvalues.

Denote by D_S^\pm the unit disk bundle of E_S^\pm with respect to some metric on E_S^\pm .

Since the Morse index and coindex of S are not equal to 1, we deduce that ∂D_S^\pm is connected. Thus, if we attach D_S^\pm to a compact CW -complex X along ∂D_S^\pm , then the resulting space will have the same number of *path* components as X .

Let $f_{\min} := \min_{x \in M} f(x)$ and $f_{\max} = \max_{x \in M} f(x)$. Observe now that if $\varepsilon > 0$ then $\{f \leq f_{\min} + \varepsilon\}$ has the same number of connected components as $\{f = f_{\min}\}$.

Indeed, if C_1, \dots, C_k are the connected components of $\{f = f_{\min}\}$, then since f is a Morse–Bott function, we deduce that for $\varepsilon > 0$ sufficiently small the sublevel set $\{f \leq f_{\min} + \varepsilon\}$ is a disjoint union of tubular neighborhoods of the C_i 's.

The manifold M is homotopic to a space obtained from the sublevel set $\{f \leq f_{\min} + \varepsilon\}$ via a finite number of attachments of the above type. Thus M must have the same number of components as $\{f = f_{\min}\}$, so that $\{f = f_{\min}\}$ is path connected. We deduce similarly that for every regular value c of f the sublevel set M^c is connected. The same argument applied to $-f$ shows that the level set $\{f = f_{\max}\}$ is connected and the suprallevel sets M_c are connected.

To proceed further we need the following simple consequence of the above observations:

$$M_{c_1}^{c_2} \text{ is path connected if } L_{c_1} \text{ is path connected.} \quad (3.15)$$

Indeed, if $p_0, p_1 \in M_{c_1}^{c_2}$, then we can find a path connecting them inside M^{c_2} . If this path is not in $M_{c_1}^{c_2}$, then there is a first moment t_0 when it intersects L_{c_1} and a last moment t_1 when it intersects this level set. Now choose a path β in L_{c_1} connecting $\gamma(t_0)$ to $\gamma(t_1)$. The path

$$p_0 \xrightarrow{\gamma} \gamma(t_0) \xrightarrow{\beta} \gamma(t_1) \xrightarrow{\gamma} p_1$$

is a path in $M_{c_1}^{c_2}$ connecting p_0 to p_1 .

Consider the set

$$C := \{c \in [f_{\min}, f_{\max}]; L_{c'} \text{ is path connected } \forall c' \leq c\} \subset \mathbb{R}.$$

We want to prove that $C = [f_{\min}, f_{\max}]$.

Note first that $C \neq \emptyset$ since $f_{\min} \in C$. Set $c_0 = \sup C$. We will prove that $c_0 \in C$ and $c_0 = f_{\max}$.

If c_0 is a regular value of f , then $L_{c_0} \cong L_{c_0 - \varepsilon}$ for all $\varepsilon > 0$ sufficiently small, so that L_{c_0} is path connected and thus $c_0 \in C$.

Suppose c_0 is a critical value of f . Since $L_{c_0 + \varepsilon}$ is path connected, we deduce from (3.15) that $M_{c_0 - \varepsilon}^{c_0 + \varepsilon}$ is path connected for all $\varepsilon > 0$.

On the other hand, the level set L_{c_0} is a Euclidean neighborhood retract (see for example [Do, IV.8] or [Ha, Theorem A.7]), and we deduce (see [Do, VIII.6] or [Spa, Section 6.9]) that

$$\varinjlim_{\varepsilon} H^{\bullet}(M_{c_0-\varepsilon}^{c_0+\varepsilon}, \mathbb{Q}) = H^{\bullet}(L_{c_0}, \mathbb{Q}),$$

where H^{\bullet} denotes the *singular cohomology*.⁹ Hence

$$H^0(L_{c_0}, \mathbb{Q}) = H^0(M_{c_0-\varepsilon}^{c_0+\varepsilon}, \mathbb{Q}) = \mathbb{Q}, \quad \forall 0 < \varepsilon \ll 1.$$

Hence L_{c_0} is path connected. This proves $c_0 \in C$.

Let us prove that if $c_0 < f_{\max}$ then $c_0 + \varepsilon \in C$, contradicting the maximality of c_0 . Clearly this happens if c_0 is a regular value, since in this case $L_{c_0+\varepsilon} \cong L_{c_0} \cong L_{c_0-\varepsilon}$, $\forall 0 < \varepsilon \ll 1$. Thus we can assume that c_0 is a critical value.

Observe that since L_{c_0} is connected, then no critical submanifold of f in the level set L_{c_0} is a local maximum of f . Indeed, if S were such a critical submanifold then because f is Bott nondegenerate, S would be an isolated path component of L_{c_0} and thus $L_{c_0} = S$. On the other hand, M_{c_0} is path connected and thus one could find a path inside this region connecting a point on S to a point on $\{f = f_{\max}\}$. Since $c_0 < f_{\max}$, this would contradict the fact S is a local maximum of f .

We deduce that for any critical submanifold S in L_{c_0} the rank of E_S^+ is at least 2, because it cannot be either zero or one. In particular, the Thom isomorphism theorem implies that

$$H^1(D_S^+, \partial D_S^+; \mathbb{Z}/2) = 0,$$

and this implies that

$$\begin{aligned} H^1(M_{c_0-\varepsilon}^{c_0+\varepsilon}, L_{c_0+\varepsilon}; \mathbb{Z}/2) &\cong H^1(M_{c_0-\varepsilon}, M_{c_0+\varepsilon}; \mathbb{Z}/2) \\ &\cong \bigoplus_S H^1(D_S^+, \partial D_S^+; \mathbb{Z}/2) = 0, \end{aligned}$$

where the summation is taken over all the critical submanifolds contained in the level set L_{c_0} , the first isomorphism is given by excision, and the second from the structural theorem Theorem 2.43. The long cohomological sequence of the pair $(M_{c_0-\varepsilon}^{c_0+\varepsilon}, L_{c_0+\varepsilon})$ then implies that the morphism

$$H^0(M_{c_0-\varepsilon}^{c_0+\varepsilon}, \mathbb{Z}/2) \rightarrow H^0(L_{c_0+\varepsilon}, \mathbb{Z}/2)$$

is onto. Using (3.15) we deduce that $H^0(M_{c_0-\varepsilon}^{c_0+\varepsilon}, \mathbb{Z}/2) = \mathbb{Z}/2$, so that $L_{c_0+\varepsilon}$ is path connected. \square

Theorem 3.48. *Suppose (M, ω) is equipped with an effective Hamiltonian action of the torus \mathbb{T} with moment map $\mu : M \rightarrow \mathfrak{t}^*$. Then every η in the interior of $\mu(M)$ is a regular value of μ ; the fiber $\mu^{-1}(\eta)$ is connected and \mathbb{T} -invariant, and the stabilizer of every point $z \in \mu^{-1}(\eta)$ is finite.*

⁹ The point of this emphasis is that only the singular cohomology H^0 counts the number of *path* components. Other incarnations of cohomology count only components.

Proof. Let $\eta \in \text{int } \mu(M)$ and $z \in \mu^{-1}(\eta)$. Denote by \mathbb{T}_z the identity component of \mathbf{St}_z . We want to prove that \mathbf{St}_z is finite, i.e., $\mathbb{T}_z = 1$.

Indeed, if $\mathbb{T}_z \neq 1$ then z is a fixed point of a nontrivial torus. Denote by C_z the component of $\text{Fix}_{\mathbb{T}_z}(M)$ containing z . From Theorem 3.45(b) we deduce that $C_z = \mu^{-1}(F)$ for some *proper* face F of $\mu(M)$ and thus $\eta = \mu(z) \in F$. This contradicts the choice of η as an interior point of $\mu(M)$.

Denote by $\dot{\mu}_z : T_z M \rightarrow T_\eta \mathfrak{t}^*$ the differential of μ . Lemma 3.42 implies $\ker \dot{\mu}_z = \mathfrak{t}_z = 0$ so that $\dot{\mu}_z$ is surjective, i.e., η is a regular value of μ . Hence $\mu^{-1}(\eta)$ is a smooth submanifold of M of codimension equal to $\dim \mathbb{T}$. Set

$$n := \dim_{\mathbb{R}} \mathbb{T}, \quad 2m := \dim_{\mathbb{R}} M.$$

Choose a basis X_1, \dots, X_n of \mathfrak{t} such that for every $i = 1, \dots, n$ the hyperplane

$$H_i := \{ \zeta \in \mathfrak{t}^*; \langle \zeta, X_i \rangle = \eta_i := \langle \eta, X_i \rangle \}$$

does not contain¹⁰ any of the vertices of $\mu(M)$. Corollary 3.43 shows that this condition is equivalent to the requirement that η_i be a regular value of $\xi_i := \xi_{X_i}$, $\forall i = 1, \dots, n$. The fiber $\mu^{-1}(\eta)$ is therefore the intersection of regular level sets of the functions ξ_i ,

$$\mu^{-1}(\eta) = \{ z \in M; \xi_i(z) = \eta_i, \forall i = 1, \dots, n \} = \bigcap_{i=1}^n \{ \xi_i = \eta_i \}.$$

Since $\{\xi_i, \xi_j\} = 0$, $\forall i, j$, we deduce from Corollary 3.26 that ξ_i is constant along the trajectories of $X_j^b = \nabla^\omega \xi_j$. This proves that any intersection of level sets of ξ_i 's is a union of flow lines of *all* of the X_j^b 's. Hence $\mu^{-1}(\eta)$ is \mathbb{T} -invariant.

For $k = 1, \dots, n$ set

$$M_k := \{ z \in M; \xi_i = \eta_i, \forall i = 1, \dots, k \}.$$

Denote by $\mathbb{T}_k \subset \mathbb{T}$ the k -dimensional closed subtorus generated by

$$\{ e^{t_i X_i}; i \leq k, t_i \in \mathbb{R} \}.$$

We will prove by induction on k that M_k is connected.

For $k = 1$ this follows from the connectivity lemma as M_1 is the level set of the Morse–Bott function ξ_1 whose Morse indices and co-indices are all even.

Assume now that M_k is connected. We will prove that M_{k+1} is connected as well.

Since M_{k+1} is a level set of $\xi_{k+1}|_{M_k}$, it suffices to show that the restriction of $\xi_{k+1}|_{M_k}$ is a Morse–Bott function whose Morse indices and coindices are all even. For notational simplicity we set $\xi := \xi_{k+1}|_{M_k}$

¹⁰ The space of hyperplanes containing η and a vertex v of $\mu(M)$ is rather “thin”. The normals of such hyperplanes must be orthogonal to the segment $[\eta, v]$, so that a generic hyperplane will not contain these vertices.

Observe first that since ξ_i is \mathbb{T} -invariant, its critical set is also \mathbb{T} -invariant. Suppose $z \in M_k$ is a critical point of ξ . This means that there exist scalars $\lambda_1, \dots, \lambda_k \in \mathbb{R}$ such that

$$d\xi_{k+1}(z) = \sum_{i=1}^k \lambda_i d\xi_i(z) \iff X_{k+1}^\flat(z) - \sum_{i=1}^k \lambda_i X_i^\flat(z) = 0.$$

Thus if we set

$$X := X_{k+1} - \sum_{i=1}^k \lambda_i X_i,$$

we deduce that z is a fixed point of \mathbb{T}_X . Denote by C_z the component of $\text{Fix}_{\mathbb{T}_X}(M)$ containing z . Then C_z is a nondegenerate critical submanifold of ξ_X .

Lemma 3.49. *C_z intersects M_k transversally.*

Let us take the lemma for granted. Set $C_{z,k} := C_z \cap M_k$. We then have¹¹

$$T_{C_{z,k}} M_k \cong T_{C_z} M,$$

so that $C_{z,k}$ is a nondegenerate critical submanifold of $\xi_X|_{M_k}$ with the same index and co-index as the critical submanifold C_z of $\xi_X : M \rightarrow \mathbb{R}$. Since

$$\xi_X = \xi_{k+1} - \sum_{i=1}^k \lambda_i \xi_i$$

we deduce that $\xi_X|_{M_k} - \xi_{k+1}|_{M_k} = \text{const}$ so that $C_{z,k}$ is a nondegenerate critical submanifold of $\xi_{k+1}|_{M_k}$ with even index and co-index. Thus, to complete the proof of Theorem 3.48 it suffices to prove Lemma 3.49.

Proof of Lemma 3.49. It suffices to show that C_z and M_k intersect transversally at z . Thus we need to prove that

$$(T_z M_k)^\perp \cap (T_z C_z)^\perp = 0,$$

where the orthogonal complements are defined in terms of a metric h equivariantly tamed by ω . Denote by J the associated almost complex structure. Observe that

¹¹ We are using the following sequence of canonical isomorphisms of vector bundles over $C_{z,k}$:

$$\begin{aligned} T_{C_{z,k}} M_k &:= TM_k / TC_{z,k} = TM_k / (TM_k \cap TC_z) \cong (TM + TC_z) / TC_z, \\ T_{C_z} M &:= TM / TC_z = (TM + TC_z) / TC_z. \end{aligned}$$

$$(T_z M_k)^\perp = \text{span}_{\mathbb{R}}\{\nabla^h \xi_i(z); i = 1, \dots, k\} = J \text{span}_{\mathbb{R}}\{X_i^b(z); i = 1, \dots, k\}.$$

Since J is \mathbb{T} -invariant, we deduce that $L_{X^b} J = 0$, and since $[X^b, X_i^b] = [X, X_i]^b = 0$ we deduce that

$$L_{X^b}(JX_i^b) = J(L_{X^b} X_i^b) = 0.$$

Corollary 3.40 implies that $JX_i \in T_z C_z$, so that $(T_z M_k)^\perp \subset T_z C_z$ and therefore

$$(T_z M_k)^\perp \cap (T_z C_z)^\perp = 0. \quad \square$$

Definition 3.50. A toric symplectic manifold is a symplectic manifold (M, ω) equipped with an effective Hamiltonian action of a torus of dimension $\frac{1}{2} \dim M$. \square

Theorem 3.51. Suppose (M, ω) is a toric symplectic manifold of dimension $2m$. We denote by \mathbb{T} the m -dimensional torus acting on M and by μ the moment map of this action. The following hold:

- (a) For every face F of $\mu(M)$ the submanifold $M_F = \mu^{-1}(F)$ is a toric manifold of dimension $2 \dim F$.
- (b) For every η in the interior of $\mu(M)$ the fiber $M_\eta = \mu^{-1}(\eta)$ is diffeomorphic to \mathbb{T} .

Proof. As in Theorem 3.45 we set

$$\mathbf{St}_F := \{g \in \mathbb{T}; gx = x, \forall x \in M_F\}.$$

Theorem 3.45 shows that \mathbf{St}_F is a closed subgroup of \mathbb{T} and

$$\dim \mathbf{St}_F = \text{codim } F = m - \dim F.$$

Thus $\mathbb{T}_\perp = \mathbb{T}/\mathbf{St}_F$ is a torus of dimension M_F acting effectively on the symplectic manifold M_F of dimension $2(m - k)$.

For part (b) observe that M_η is a *connected* \mathbb{T} -invariant submanifold of M of dimension m . Let \mathcal{O} denote an orbit of \mathbb{T} on M_η . Then \mathcal{O} is a compact subset of M_η . Denote by G the stabilizer of a point in \mathcal{O} , so that

$$\mathcal{O} = \mathbb{T}/G.$$

On the other hand, by Theorem 3.48, G is a finite group, and since $\dim \mathbb{T} = m = \dim M_\eta$, we deduce that the orbit \mathcal{O} is an *open* subset of M_η . Hence $\mathcal{O} = M_\eta$ because \mathcal{O} is also a *closed* subset of M_η and M_η is connected. The isomorphism $\mathcal{O} = \mathbb{T}/G$ shows that M_η is a finite (free) quotient of \mathbb{T} so that $M_\eta \cong \mathbb{T}$. \square

Example 3.52 (A toric structure on $\mathbb{C}\mathbb{P}^2$). Consider the action of the two torus $\mathbb{T} = S^1 \times S^1$ on $\mathbb{C}\mathbb{P}^2$ described in Example 3.36. More precisely, we have

$$\begin{aligned} [z_0, z_1, z_2] \cdot (e^{it_1}, e^{it_2}) &= [e^{-i(t_1+t_2)} z_0, e^{it_1} z_1, e^{it_2} z_2] \\ &= [z_0, e^{(2t_1+t_2)i} z_1, e^{(t_1+2t_2)i} z_2], \end{aligned} \quad (3.16)$$

with Hamiltonian function

$$\mu([z_0, z_1, z_2]) = \frac{1}{|z|^2} (|z_0|^2, |z_1|^2, |z_2|^2) - \frac{1}{3}(1, 1, 1) \in \mathfrak{t}.$$

Set $\mathbf{b} := \frac{1}{3}(1, 1, 1)$.

This action is not effective because the subgroup

$$G = \{(\rho, \rho) \in \mathbb{T}; \rho^3 = 1\} \cong \mathbb{Z}/3$$

acts trivially. To obtain an effective action we need to factor out this subgroup and look at the action of \mathbb{T}^2/G . We will do this a bit later.

The Lie algebra of \mathbb{T} is identified with the subspace

$$\mathfrak{t} = \{\mathbf{w} \in \mathbb{R}^3; w_0 + w_1 + w_2 = 0\}.$$

The vector $\mathbf{w} \in \mathfrak{t}$ generates the Hamiltonian flow

$$\Phi_t^\lambda([z_0, z_1, z_2]) = [e^{iw_0 t} z_0, e^{iw_1 t} z_1, e^{iw_2 t} z_2]$$

with Hamiltonian function

$$\xi_{\mathbf{w}} = \frac{w_0|z_0|^2 + w_1|z_1|^2 + w_2|z_2|^2}{|z|^2}.$$

We can now explain how to concretely factor out the action of G . This is done in two steps as follows.

Step 1. Construct a smooth surjective morphism of two dimensional tori $\varphi : \mathbb{T} \rightarrow \mathbb{T}_0$ such that $\ker \varphi = G$.

Step 2. Define a new action of \mathbb{T}_0 on $\mathbb{C}\mathbb{P}^2$ by setting

$$[z_0, z_1, z_2] \cdot g = [z_0, z_1, z_2] \cdot \varphi^{-1}(g), \quad g \in \mathbb{T}_0,$$

where $\varphi^{-1}(g)$ denotes an element $h \in \mathbb{T}$ such that $\varphi(h) = g$. The choice of h is irrelevant since two different choices differ by an element in G which acts trivially on $\mathbb{C}\mathbb{P}^2$.

Step 1 does not have a unique solution, but formula (3.16) already suggests one. Define

$$\varphi : \mathbb{T} \rightarrow \mathbb{T}_0 = S^1 \times S^1, \quad \mathbb{T} \ni (e^{it_1}, e^{it_2}) \longmapsto (e^{i(2t_1+t_2)}, e^{i(t_1+2t_2)}) \in \mathbb{T}_0.$$

To find its “inverse” it suffices to find the inverse of $A = D\varphi|_1 : \mathfrak{t} \rightarrow \mathfrak{t}_0$. Using the canonical bases of \mathbb{T} given by the identifications $\mathbb{T} = S^1 \times S^1 = \mathbb{T}_0$ we deduce

$$A = \begin{bmatrix} 2 & 1 \\ 1 & 2 \end{bmatrix}, \quad A^{-1} = \frac{1}{3} \begin{bmatrix} 2 & -1 \\ -1 & 2 \end{bmatrix},$$

and

$$\mathbb{T}_0 \ni (e^{is_1}, e^{is_2}) \xrightarrow{\varphi^{-1}} \left(e^{i(2s_1-s_2)/3}, e^{i(-s_1+2s_2)/3} \right) \in \mathbb{T}.$$

The action of \mathbb{T}_0 on $\mathbb{C}\mathbb{P}^2$ is then given by

$$\begin{aligned} [z_0, z_1, z_2] \cdot (e^{is_1}, e^{is_2}) &= \left[e^{-(s_1+s_2)i/3} z_0, e^{(2s_1-s_2)i/3} z_1, e^{(-s_1+2s_2)i/3} z_2 \right] \\ &= [z_0, e^{s_1 i} z_1, e^{s_2 i} z_2]. \end{aligned} \tag{3.17}$$

Note that

$$\mathfrak{t}_0 \ni \partial_{s_1} \xrightarrow{A^{-1}} \mathbf{w}_1 = \frac{1}{3} \left(-1, \underbrace{2, -1}_{\text{first column of } A^{-1}} \right) \in \mathfrak{t},$$

and

$$\mathfrak{t}_0 \ni \partial_{s_2} \xrightarrow{A^{-1}} \mathbf{w}_2 = \frac{1}{3} \left(-1, \underbrace{-1, 2}_{\text{second column of } A^{-1}} \right) \in \mathfrak{t}.$$

The vector ∂_{s_i} generates the Hamiltonian flow $\Psi_t^i = \Phi_t^{\mathbf{w}_i}$ with Hamiltonian function $\chi_i := \xi_{\mathbf{w}_i}$. More explicitly,

$$\chi_1 = \frac{-|z_0|^2 + 2|z_1|^2 - |z_2|^2}{3|\mathbf{z}|^2}, \quad \chi_2 = \frac{-|z_0|^2 - |z_1|^2 + 2|z_2|^2}{3|\mathbf{z}|^2}.$$

Using the equality $|\mathbf{z}|^2 = |z_0|^2 + |z_1|^2 + |z_2|^2$, we deduce¹²

$$\chi_i = \frac{|z_i|^2}{|\mathbf{z}|^2} - \frac{1}{3}, \quad i = 1, 2.$$

We can thus take as moment map of the action of \mathbb{T}_0 on $\mathbb{C}\mathbb{P}^2$ the function

$$\nu([z_0, z_1, z_2]) = (\nu_1, \nu_2), \quad \nu_i = \chi_i + \frac{1}{3}$$

because the addition of a constant to a function changes neither the Hamiltonian flow it determines nor the Poisson brackets with other functions.

For the equality (3.17) we deduce that the fixed points of this action are

$$P_0 = [1, 0, 0], \quad P_1 = [0, 1, 0], \quad P_2 = [0, 0, 1].$$

Set $\nu_i = \nu(P_i)$, so that

$$\nu_0 = (0, 0), \quad \nu_1 = (1, 0), \quad \nu_2 = (0, 1).$$

The image of the moment map μ is the triangle Δ in \mathfrak{t}_0 with vertices $\nu_0 \nu_1 \nu_2$. Denote by E_i the edge of Δ opposite the vertex ν_i . We deduce that $\nu^{-1}(E_i)$ is the hyperplane in $\mathbb{C}\mathbb{P}^2$ described by $z_0 = 0$.

¹² Compare this result with the harmonic oscillator computations in Example 3.32.

As explained in Theorem 3.45, the line ℓ_i through the origin of \mathfrak{t} and perpendicular to E_i generates a 1-dimensional torus \mathbb{T}_{E_i} and $E_i = \text{Fix}_{\mathbb{T}_{E_i}}(\mathbb{C}\mathbb{P}^2)$. We have

$$\mathbb{T}_{E_0} = \{(e^{si}, e^{si}); s \in \mathbb{R}\}, \quad \mathbb{T}_{E_1} = \{(1, e^{si}); s \in \mathbb{R}\}, \quad \mathbb{T}_{E_2} = \{(e^{si}, 1); s \in \mathbb{R}\}.$$

Observe that the complex manifold

$$X := \nu^{-1}(\text{int } \Delta) = \mathbb{C}\mathbb{P}^2 \setminus \left(\mu^{-1}(E_0) \cup \mu^{-1}(E_1) \cup \mu^{-1}(E_2) \right)$$

is biholomorphic to the complexified torus $\mathbb{T}_0^{\mathbb{C}} = \mathbb{C}^* \times \mathbb{C}^*$ via the \mathbb{T}_0 -equivariant map

$$X \ni [z_0, z_1, z_2] \xrightarrow{\Phi} (\zeta_1, \zeta_2) = (z_1/z_0, z_2/z_1) \in \mathbb{C}^* \times \mathbb{C}^*.$$

For $\rho = (\rho_1, \rho_2) \in \text{int } (\Delta)$ we have

$$\begin{aligned} \nu^{-1}(\rho) &= \{ [1, z_1, z_2] \in \mathbb{C}\mathbb{P}^2; |z_i|^2 = \rho_i(1 + |z_1|^2 + |z_2|^2) \} \\ &= \{ [1, z_2, z_2]; |z_i|^2 = r_i \}, \quad r_i = \frac{\rho_i(\rho_1 + \rho_2)}{1 - (\rho_1 + \rho_2)}. \end{aligned}$$

This shows what happens to the fiber $\nu^{-1}(\rho)$ as ρ approaches one of the edges E_i . For example, as ρ approaches the edge E_1 given by $\rho_1 = 0$, the torus $\nu^{-1}(\rho)$ is shrinking in one direction since the codimension one cycle $|z_1|^2 = r_1$ on $\nu^{-1}(\rho)$ degenerates to a point as $\rho \rightarrow 0$. \square

3.5 S^1 -Equivariant Localization

The goal of this section is to prove that the Morse–Bott functions determined by the moment map of a Hamiltonian torus action are *perfect*. We will use the strategy in [Fra] based on a result of P. Conner (Corollary 3.69) relating the Betti numbers of a smooth manifold equipped with a smooth S^1 -action to the Betti numbers of the fixed point set.

To prove Conner’s result we use the equivariant localization theorem of Atiyah and Bott [AB2] which will require a brief digression into S^1 -equivariant cohomology. For simplicity we write $H^\bullet(X) := H^\bullet(X, \mathbb{C})$ for any topological space X .

Denote by S^∞ the unit sphere in an infinite dimensional, separable, complex Hilbert space. It is well known (see e.g. [Ha, Example 1.B.3]) that S^∞ is contractible. Using the identification

$$S^1 = \{z \in \mathbb{C}; |z| = 1\}$$

we see that there is a tautological *right free* action of S^1 on S^∞ . The quotient $BS^1 := S^\infty/S^1$ is the infinite dimensional complex projective space $\mathbb{C}\mathbb{P}^\infty$.

Its cohomology ring with complex coefficients is isomorphic to the ring of polynomials with complex coefficients in one variable of degree 2,

$$H^\bullet(BS^1) \cong \mathbb{C}[\tau], \quad \deg \tau = 2.$$

We obtain a principal S^1 -bundle $S^\infty \rightarrow BS^1$. To any principal S^1 -bundle $S^1 \hookrightarrow P \twoheadrightarrow B$ and any linear representation $\rho : S^1 \rightarrow \text{Aut}(\mathbb{C}) = \mathbb{C}^*$ we can associate a complex line bundle $L_\rho \rightarrow B$ whose total space is given by the quotient

$$P \times_\rho \mathbb{C} = (P \times \mathbb{C})/S^1,$$

where the *right action* of S^1 on $P \times \mathbb{C}$ is given by

$$(p, \zeta) \cdot e^{i\varphi} := (p \cdot e^{i\varphi}, \rho(e^{-i\varphi})\zeta), \quad \forall (p, \zeta) \in P \times \mathbb{C}, \quad e^{i\varphi} \in S^1.$$

L_ρ is called the *complex line bundle associated* with the principal S^1 -bundle $P \twoheadrightarrow B$ and the representation ρ . When ρ is the tautological representation given by the inclusion $S^1 \rightarrow \mathbb{C}^*$ we will say simply that L is the *complex line bundle associated with the principal S^1 -bundle*.

Example 3.53. Consider the usual action of S^1 on $S^{2n+1} \subset \mathbb{C}^{n+1}$. The quotient space is $\mathbb{C}\mathbb{P}^n$ and the S^1 -bundle $S^{2n+1} \rightarrow \mathbb{C}\mathbb{P}^n$ is called the *Hopf bundle*. Consider the identity morphism

$$\rho_1 : S^1 \rightarrow S^1 \subset \text{Aut}(\mathbb{C}), \quad e^{it} \mapsto e^{it}.$$

The associated line bundle

$$S^{2n+1} \times_{\rho_1} \mathbb{C} \rightarrow \mathbb{C}\mathbb{P}^n$$

can be identified with the tautological line bundle $\mathbb{U}_n \rightarrow \mathbb{C}\mathbb{P}^n$.

To see this, note that we have an S^1 -invariant smooth map

$$S^{2n+1} \times \mathbb{C} \rightarrow \mathbb{C}\mathbb{P}^n \times \mathbb{C}^{n+1},$$

given by

$$S^{2n+1} \times \mathbb{C} \ni (z_0, \dots, z_n, z) \mapsto ([z_0, \dots, z_n], (zz_0, \dots, zz_n))$$

which produces the desired isomorphism between $S^{2n+1} \times_{\rho_1} \mathbb{C}$ and the tautological line bundle \mathbb{U}_n .

More generally, for every integer m we denote by $\mathcal{O}(m) \rightarrow \mathbb{C}\mathbb{P}^n$ the line bundle associated with the Hopf bundle and the representation

$$\rho_{-m} : S^1 \rightarrow S^1, \quad e^{it} \mapsto e^{-mit}.$$

Thus $\mathcal{O}(-1) \cong \mathbb{U}_n$.

Observe that the sections of $\mathcal{O}(m)$ are given by smooth maps

$$\sigma : S^{2n+1} \rightarrow \mathbb{C}$$

satisfying

$$\sigma(e^{it}v) = e^{mit}\sigma(v).$$

Thus, if $m \geq 0$, and $P \in \mathbb{C}[z_0, \dots, z_n]$ is a homogeneous polynomial of degree m , then the smooth map

$$S^{2n+1} \ni (z_0, \dots, z_n) \mapsto P(z_0, \dots, z_n)$$

defines a section of $\mathcal{O}(m)$. □

We denote by $U_\infty \rightarrow BS^1$ the complex line bundle associated with the S^1 -bundle $S^\infty \rightarrow BS^1$. The space BS^1 is usually referred to as the *classifying space* of the group S^1 , while U_∞ is called the *universal line bundle*. To explain the reason behind this terminology we need to recall a few classical facts.

To any complex line bundle L over a CW -complex X we can associate a cohomology class $e(L) \in H^2(X)$ called the *Euler class* of L . It is defined by

$$e(L) := i^* \tau_L,$$

where $i : X \rightarrow L$ denotes the zero section inclusion, D_L denotes the unit disk bundle of L , and $\tau_L = H^2(D_L, \partial D_L; \mathbb{C})$ denotes the Thom class of L determined by the canonical orientation defined by the complex structure on L .

The Euler class is natural in the following sense. Given a continuous map $f : X \rightarrow Y$ between CW -complexes and a complex line bundle $L \rightarrow Y$, then

$$e(f^*L) = f^*e(L),$$

where $f^*L \rightarrow X$ denotes the pullback of $L \rightarrow Y$ via f .

Often the following result is very useful in determining the Euler class.

Theorem 3.54 (Gauss–Bonnet–Chern). *Suppose X is a compact oriented smooth manifold, $L \rightarrow X$ is a complex line bundle over X , and $\sigma : X \rightarrow L$ is a smooth section of L vanishing transversally. This means that near a point $x_0 \in \sigma^{-1}(0)$ the section σ can be represented as a smooth map $\sigma : X \rightarrow \mathbb{C}$ that is a submersion at x_0 . Then $S := \sigma^{-1}(0)$ is a smooth submanifold of X . It has a natural orientation induced from the orientation of TX and the canonical orientation of L via the isomorphism*

$$L|_S \cong (TX)|_S/TS.$$

Then $[S]$ determines a homology class that is Poincaré dual to $e(L)$. □

For a proof we refer to [BT, Proposition 6.24].

Example 3.55. The Euler class of the line bundle $\mathcal{O}(1) \rightarrow \mathbb{C}\mathbb{P}^n$ is the Poincaré dual of the homology class determined by the zero set of the section described in Example 3.53. This zero set is the hyperplane

$$H = \{ [z_0, z_1, \dots, z_n]; z_0 = 0 \}.$$

Its Poincaré dual is the canonical generator of $H^\bullet(\mathbb{C}\mathbb{P}^n)$. □

The importance of BS^1 stems from the following fundamental result [MS, §14].

Theorem 3.56. *Suppose X is a CW-complex. Then for every complex line bundle $L \rightarrow X$ there exists a continuous map $f : X \rightarrow BS^1$ and a line bundle isomorphism $f^*U_\infty \cong L$. Moreover,*

$$e(L) = f^*e(U_\infty) = -f^*(\tau) \in H^2(X),$$

where τ is the canonical generator¹³ of $H^2(\mathbb{C}\mathbb{P}^\infty)$. □

The cohomology of the total space of a circle bundle enters into a long exact sequence known as the *Gysin sequence*. For the reader's convenience we include here the statement and the proof of this result.

Theorem 3.57 (Gysin). *Suppose $S^1 \hookrightarrow P \xrightarrow{\pi} B$ is a principal S^1 -bundle over a CW-complex. Denote by $L \rightarrow B$ the associated complex line bundle and by $e = e(L) \in H^2(B, \mathbb{C})$ its Euler class. Then we have the following long exact sequence:*

$$\dots \rightarrow H^\bullet(P) \xrightarrow{\pi_!} H^{\bullet-1}(B) \xrightarrow{e \cup} H^{\bullet+1}(B) \xrightarrow{\pi^*} H^{\bullet+1}(P) \rightarrow \dots \quad (3.18)$$

The morphism $\pi_! : H^\bullet(P) \rightarrow H^{\bullet-1}(B)$ is called the Gysin map.

Proof. Denote by D_L the unit disk bundle of L determined by a Hermitian metric on L . Then ∂D_L is isomorphic as an S^1 -bundle to P . Denote by $i : B \rightarrow D_L$ the zero section inclusion. We have a Thom isomorphism

$$i_! : H^\bullet(B) \rightarrow H^{\bullet+2}(D_L, \partial D_L),$$

$$H^\bullet(B) \ni \beta \mapsto \tau_L \cup \pi^* \beta \in H^{\bullet+2}(D_L, \partial D_L).$$

Consider now the following diagram, in which the top row is the long exact cohomological sequence of the pair $(D_L, \partial D_L)$, all the vertical arrows are isomorphisms, and r, q are restriction maps (i.e., pullbacks by inclusions)

¹³ The minus sign in the above formula comes from the fact that the Euler class of the tautological line bundle over $\mathbb{C}\mathbb{P}^1 \cong S^2$ is the opposite of the generator of $H^2(\mathbb{C}\mathbb{P}^1)$ determined by the orientation of $\mathbb{C}\mathbb{P}^1$ as a complex manifold.

$$\begin{array}{ccccc}
 \xrightarrow{q} H^\bullet(\partial D_L) & \xrightarrow{\delta} & H^{\bullet+1}(D_L, \partial D_L) & \xrightarrow{r} & H^{\bullet+1}(D_L) \xrightarrow{q} \\
 \uparrow j & & \uparrow i_! & & \downarrow i^* \\
 H^\bullet(P) & & H^{\bullet-1}(B) & & H^{\bullet+1}(B)
 \end{array}$$

The bottom row can thus be completed to a long exact sequence, where the morphism $H^{\bullet-1}(B) \rightarrow H^{\bullet+1}(B)$ is given by

$$i^* r i_!(\alpha) = i^*(\tau_L \cup \pi^* \alpha) = i^*(\tau_L) \cup i^* \pi^*(\alpha) = e \cup \alpha, \quad \forall \alpha \in H^{\bullet-1}(B). \quad \square$$

Definition 3.58. (a) We define a left (respectively right) S^1 -space to be a topological space X together with a continuous left (respectively right) S^1 -action. The set of orbits of a left (resp. right) action is denoted by $S^1 \backslash X$ (respectively X/S^1).

(b) An S^1 -map between left S^1 -spaces X, Y is a continuous S^1 -equivariant map $X \rightarrow Y$.

(c) If X is a left S^1 -space we define

$$X_{S^1} := (S^\infty \times X)/S^1,$$

where the right action of S^1 on $P_X := (S^\infty \times X)$ is given by

$$(v, x) \cdot e^{it} := (v \cdot e^{it}, e^{-it} x), \quad \forall (v, x) \in S^\infty \times X, \quad t \in \mathbb{R}.$$

(d) We define the S^1 -equivariant cohomology of X to be

$$H_{S^1}^\bullet(X) := H^\bullet(X_{S^1}). \quad \square$$

Remark 3.59 (Warning!). Note that to any left action of a group G on a set S ,

$$G \times X \rightarrow S, \quad (g, s) \mapsto g \cdot s,$$

there is an associated right action

$$S \times G \rightarrow S, \quad (s, g) \mapsto s \circ g := g^{-1} \cdot s.$$

We will refer to it as the *right action* dual to the left action. Note that these two actions have the same sets of orbits, i.e.,

$$G \backslash S = S/G.$$

If S is a topological space and the left action of G is continuous then the spaces S/G and $G \backslash S$ with the quotient topologies are tautologically homeomorphic.

The differences between right and left actions tend to be blurred even more when the group G happens to be Abelian, because in this case there is another right action

$$S \times G \rightarrow S, \quad (s, g) \mapsto s * g = g \cdot s.$$

The \circ and $*$ actions are sometime confused leading to sign errors in computations of characteristic classes. \square

In the sequel we will work exclusively with *left* S^1 -spaces, and therefore we will refer to them simply as S^1 -spaces.

The natural S^1 -equivariant projection $S^\infty \times X \rightarrow S^\infty$ induces a continuous map

$$\Psi : X_{S^1} \rightarrow BS^1.$$

We denote by \mathcal{L}_X the complex line bundle $\Psi^*U_\infty \rightarrow X_{S^1}$.

Proposition 3.60. \mathcal{L}_X is isomorphic to the complex line bundle associated with the principal S^1 -bundle

$$S^1 \hookrightarrow P_X \rightarrow X_{S^1}$$

Proof. Argue exactly as in Example 3.53. □

We set $z := e(\mathcal{L}_X) \in H^2(X_{S^1})$. The \cup -product with z defines a structure of a $\mathbb{C}[z]$ -module on $H_{S^1}^\bullet(X)$. In fact, when we think of the equivariant cohomology of an S^1 -space, we think of a $\mathbb{C}[z]$ -module because it is through this additional structure that we gain information about the action of S^1 .

The module $H_{S^1}^\bullet(X)$ has a $\mathbb{Z}/2$ -grading given by the parity of the degree of a cohomology class, and the multiplication by z preserves this parity. We denote by $H_{S^1}^\pm(X)$ its even/odd part. Let us point out that $H_{S^1}^\bullet(X)$ is *not* \mathbb{Z} -graded as a $\mathbb{C}[z]$ -module.

Any S^1 -map between S^1 -spaces $f : X \rightarrow Y$ induces a morphism of $\mathbb{C}[z]$ -modules

$$f^* : H_{S^1}^\bullet(Y) \rightarrow H_{S^1}^\bullet(X),$$

and given any S^1 -invariant subset Y of an S^1 -space X we obtain a long exact sequence of $\mathbb{C}[z]$ -modules

$$\cdots \rightarrow H_{S^1}^\bullet(X, Y) \rightarrow H_{S^1}^\bullet(X) \rightarrow H_{S^1}^\bullet(Y) \xrightarrow{\delta} H_{S^1}^{\bullet+1}(X, Y) \rightarrow \cdots,$$

where

$$H_{S^1}^\bullet(X, Y) := H^\bullet(X_{S^1}, Y_{S^1}).$$

Moreover, any S^1 -maps that are equivariantly homotopic induce identical maps in equivariant cohomology.

Example 3.61. (a) Observe that if X is a point $*$, then

$$H_{S^1}^\bullet(*) \cong H^\bullet(BS^1) = \mathbb{C}[\tau].$$

Any S^1 -space X is equipped with a *collapse map* $c_X : X \rightarrow \{*\}$ that induces a morphism

$$c_X^* : \mathbb{C}[\tau] \rightarrow H_{S^1}^\bullet(X).$$

We see that c_X^* induces the canonical $\mathbb{C}[z]$ -module structure on $H_{S^1}^\bullet(X)$, where $z = c_X^*(-\tau)$.

(b) Suppose that S^1 acts trivially on X . Then

$$X_{S^1} = BS^1 \times X, \quad H_{S^1}^\bullet(X) \cong H^\bullet(BS^1) \otimes H^\bullet(X) \cong \mathbb{C}[\tau] \otimes H^\bullet(X)$$

and $z = -\tau$. Hence $H_{S^1}^\bullet(X)$ is a free $\mathbb{C}[z]$ -module.

(c) Suppose X is a *left* S^1 -space such that S^1 acts freely on X . The natural map $(S^\infty \times X) \rightarrow X$ is equivariant (with respect to the right action on $S^\infty \times X$ and the dual right action on X) and induces a map

$$X_{S^1} = (S^\infty \times X)/S^1 \rightarrow X/S^1.$$

If X and X/S^1 are a reasonable spaces (e.g., are locally contractible), then the map $\pi : X_{S^1} \rightarrow X/S^1$ is a fibration with fiber S^∞ . The long exact homotopy sequence of this fibration shows that π is a weak homotopy equivalence and thus induces an isomorphism in homology (see [Ha, Proposition 4.21]). In particular, $H_{S^1}^\bullet(X) \cong H^\bullet(X/S^1)$.

If $e(X/S^1)$ denotes the Euler class of the S^1 -bundle $X \rightarrow X/S^1$, then the multiplication by z is given by the cup product with $e(X/S^1)$. In particular, z is nilpotent. For example, if

$$X = S^{2n+1} = \left\{ (z_0, z_1, \dots, z_n) \in \mathbb{C}^{n+1}; \sum_k |z_k|^2 = 1 \right\},$$

and the action of S^1 is given by

$$e^{it} \cdot (z_0, \dots, z_n) = (e^{it} z_0, \dots, e^{it} z_n),$$

then $X/S^1 = \mathbb{C}\mathbb{P}^n$ and

$$H_{S^1}^\bullet(X) = H^\bullet(\mathbb{C}\mathbb{P}^n) \cong \mathbb{C}[z]/(z^{n+1}), \quad \deg z = 2.$$

(d) For every nonzero integer k denote by $[S^1, k]$ the circle S^1 equipped with the action of S^1 given by

$$S^1 \times [S^1, k] \ni (z, u) \mapsto z^k \cdot u.$$

Equivalently, we can regard $[S^1, k]$ as the quotient $S^1/\mathbb{Z}/k$ equipped with the natural action of S^1 . We want to prove that

$$H_{S^1}^\bullet([S^1, k]) = H^0(*) = \mathbb{C},$$

where $*$ denotes a space consisting of a single point. We have a fibration

$$\mathbb{Z}/k \hookrightarrow \underbrace{(S^\infty \times S^1)/S^1}_{:=L_1} \xrightarrow{\pi} \underbrace{(S^\infty \times [S^1, k])/S^1}_{:=L_k}.$$

In other words, L_1 is a cyclic covering space of L_k .

Note that $L_1 \cong S^\infty$ is contractible and

$$H^\bullet(L_k) = H_{S^1}^\bullet([S^1, k]).$$

We claim that

$$H_m(L_k, \mathbb{C}) = 0, \quad \forall m > 0, \quad (3.19)$$

so that $H_{S^1}^\bullet([S^1, k]) = H^0(*) = \mathbb{C}$.

To prove the claim, observe first that the action of \mathbb{Z}/k induces a free action on the set of singular simplices in L_1 and thus a linear action on the vector space $C_\bullet(L_1, \mathbb{C})$ of singular chains in L_1 with complex coefficients. We denote this action by

$$\mathbb{Z}/k \times c \ni (\rho, c) \mapsto \rho \circ c.$$

We denote by $\bar{C}_\bullet(L_1, \mathbb{C})$ the subcomplex of $C_\bullet(L_1, \mathbb{X})$ consisting of \mathbb{Z}/k -invariant chains.

We obtain by averaging a natural projection,

$$\mathbf{a} := C_\bullet(L_1, \mathbb{C}) \rightarrow \bar{C}_\bullet(L_1, \mathbb{C}), \quad c \mapsto \mathbf{a}(c) := \frac{1}{k} \sum_{\rho \in \mathbb{Z}/k} \rho \circ c.$$

This defines a *morphism of chain complexes*

$$\mathbf{a} : C_\bullet(L_1, \mathbb{C}) \rightarrow \bar{C}_\bullet(L_1, \mathbb{C}),$$

with image $\bar{C}_\bullet(L_1, \mathbb{C})$.

Each singular m -simplex σ in L_k admits precisely k -lifts to L_1 ,

$$\tilde{\sigma}^1, \dots, \tilde{\sigma}^k : \Delta_m \rightarrow L_1.$$

These lifts form an orbit of the \mathbb{Z}/k action on the set of singular simplices in L_1 . We define a map

$$C_m(L_k, \mathbb{C}) \rightarrow C_m(L_1, \mathbb{C}), \quad c = \sum_{\alpha} z_{\alpha} \sigma_{\alpha} \mapsto \hat{c} = \sum_{\alpha} z_{\alpha} \hat{\sigma}_{\alpha},$$

where

$$\hat{\sigma} := \frac{1}{k} \sum_{i=1}^k \tilde{\sigma}^i, \quad \forall \sigma : \Delta_m \rightarrow L_k.$$

Clearly \hat{c} is \mathbb{Z}/k -invariant and

$$\widehat{\partial c} = \partial \hat{c}.$$

We have thus produced a *morphism of chain complexes*

$$\pi^! : C_\bullet(L_k, \mathbb{C}) \rightarrow \bar{C}_\bullet(L_1, \mathbb{C}), \quad c \mapsto \hat{c}.$$

Denote by π_* the morphism of chain complexes $C_\bullet(L_1, \mathbb{C}) \rightarrow C_\bullet(L_k, \mathbb{C})$ induced by the projection $\pi : L_1 \rightarrow L_k$. Observe that

$$\pi^! \circ \pi_* = \mathbf{a}.$$

This shows that the restriction of the morphism π_* to the subcomplex $\bar{C}_\bullet(L_1, \mathbb{C})$ of invariant chains is injective.

Suppose now that c is a singular chain in $C_m(L_k, \mathbb{Z})$ such that $\partial c = 0$. Then

$$\pi_* \hat{c} = c, \quad \pi_*(\partial \hat{c}) = \partial \pi_* \hat{c} = \partial c = 0.$$

Since $\partial \hat{c}$ is an invariant chain and π_* is injective on the space of invariant chains we deduce $\partial \hat{c} = 0$.

On the other hand, L_1 is contractible, so there exists $\hat{u} \in C_{m-1}(L_1, \mathbb{C})$ such that $\partial \hat{u} = \hat{c}$. Thus

$$c = \pi_* \hat{c} = \pi_* \partial \hat{u} = \partial \pi_* \hat{u}.$$

This shows that every m -cycle in L_k is a boundary.

(e) Suppose $X = \mathbb{C}$ and S^1 acts on X via

$$S^1 \times \mathbb{C} \ni (e^{it}, z) \mapsto e^{-mit} z.$$

Then X_{S^1} is the total space of the complex line bundle $\mathcal{O}(m) \rightarrow \mathbb{C}\mathbb{P}^\infty$. \square

Remark 3.62. The spaces L_k in Example 3.61(c) are the Eilenberg–Mac Lane spaces $K(\mathbb{Z}/k, 1)$ while BS^1 is the Eilenberg–Mac Lane space $K(\mathbb{Z}, 2)$. We have (see [Ha, Example 2.43])

$$H_m(L_k, \mathbb{Z}) = \begin{cases} \mathbb{Z} & \text{if } m = 0, \\ 0 & \text{if } m \text{ is even and positive,} \\ \mathbb{Z}/k & \text{if } m \text{ is odd.} \end{cases} \quad \square$$

We will say that a topological space X has *finite type* if its singular homology with complex coefficients is a finite dimensional vector space, i.e.,

$$\sum_k b_k(X) < \infty.$$

An S^1 -space is said to be of *finite type* if its equivariant cohomology is a finitely generated $\mathbb{C}[z]$ -module.

Proposition 3.63. *If X is a reasonable space (e.g., a Euclidean neighborhood retract, ENR¹⁴) and X has finite type, then for any S^1 -action on X the resulting S^1 -space has finite type.*

¹⁴ For example, any compact CW -complex is an ENR or the zero set of an analytic map $F : \mathbb{R}^n \rightarrow \mathbb{R}^m$ is an ENR . For more details we refer to the appendix of [Ha].

Proof. X_{S^1} is the total space of a locally trivial fibration

$$X \hookrightarrow X_{S^1} \rightarrow B_{S^1}$$

and the cohomology of X_{S^1} is determined by the Leray–Serre spectral sequence of this fibration whose E_2 -term is

$$E_2^{p,q} = H^p(BS^1) \otimes H^q(X).$$

The complex E_2 has a natural structure of a *finitely generated* $\mathbb{C}[z]$ -module. The class z lives in $E_2^{2,0}$, so that $d_2 z = 0$. Since the differential d_2 is an odd derivation with respect to the \cup -product structure on E_2 (see [BT, Theorem 15.11]), we deduce that d_2 commutes with multiplication by z , so that d_2 is a morphism of $\mathbb{C}[z]$ -modules. Hence the later terms E_r of the spectral sequence will be *finitely generated* $\mathbb{C}[z]$ -modules since they are quotients of submodules of finitely generated $\mathbb{C}[z]$ -modules. If we let $r > 0$ denote the largest integer such that $b_r(X) \neq 0$, we deduce that

$$E_{r+1} = E_{r+2} = \cdots = E_\infty.$$

Hence E_∞ is a finitely generated $\mathbb{C}[z]$ -module. This proves that $H_{S^1}^\bullet(X)$ is an iterated extension of a finitely generated $\mathbb{C}[z]$ -module by modules of the same type. \square

The finitely generated $\mathbb{C}[z]$ -modules have a simple structure. Any such module M fits in a short (split) exact sequence of $\mathbb{C}[z]$ -modules

$$0 \rightarrow M_{\text{tors}} \rightarrow M \rightarrow M_{\text{free}} \rightarrow 0.$$

If M is $\mathbb{Z}/2$ -graded, and z is even, then there are induced $\mathbb{Z}/2$ -gradings in M_{free} and M_{tors} , so that the even/odd parts of the above sequence are also exact sequences.

The free part M_{free} has the form $\bigoplus_{i=1}^r \mathbb{C}[z]$, where the positive integer r is called the *rank* of M and is denoted by $\text{rank}_{\mathbb{C}[z]} M$. The classification of finitely generated torsion $\mathbb{C}[z]$ -modules is equivalent to the classification of endomorphisms of finite dimensional complex vector spaces according to their normal Jordan form.

If T is a finitely generated torsion $\mathbb{C}[z]$ -module then as a \mathbb{C} -vector space T is finite dimensional. The multiplication by z defines a \mathbb{C} -linear map

$$A_z : T \rightarrow T, \quad T \ni t \mapsto z \cdot t.$$

Denote by $P_z(\lambda)$ the characteristic polynomial of A_z , $P_z(\lambda) = \det(\lambda \mathbb{1}_T - A_z)$. The *support* of T is defined by

$$\text{supp } T := \{a \in \mathbb{C}; P_z(a) = 0\}.$$

For a free $\mathbb{C}[z]$ -module M we define $\text{supp } M := \mathbb{C}$. For an arbitrary $\mathbb{C}[z]$ -module M we now set

$$\operatorname{supp} M = \operatorname{supp} M_{\text{tors}} \cup \operatorname{supp} M_{\text{free}}.$$

Thus a finitely generated $\mathbb{C}[z]$ -module M is torsion if and only if its support is finite. Note that for such a module we have the equivalence

$$\operatorname{supp} M = \{0\} \iff \exists n \in \mathbb{Z}_{>0} : z^n \cdot m = 0, \quad \forall m \in M.$$

We say that a $\mathbb{C}[z]$ -module M is *negligible* if it is finitely generated and $\operatorname{supp} M = \{0\}$. Similarly, an S^1 -space X is called *negligible* if it has finite type and $H_{S^1}^\bullet(X)$ is a negligible $\mathbb{C}[z]$ -module

$$\operatorname{supp} M = \{0\}.$$

The negligible modules are pure torsion modules. Example 3.61 shows that if the action of S^1 on X is free and of finite type then X is negligible, while if S^1 acts trivially on X then $H_{S^1}^\bullet(X)_{\text{tors}} = 0$.

For an S^1 -action on a compact smooth manifold M the *equivariant localization theorem* of A. Borel [Bo] and Atiyah–Bott [AB2] essentially says that the free part of $H_{S^1}^\bullet(M)$ is due entirely to the fixed point set of the action.

Theorem 3.64. *Suppose S^1 acts smoothly and effectively on the compact smooth manifold M . Denote by $F = \operatorname{Fix}_{S^1}(M)$ the fixed point set of this action,*

$$F = \{x \in M; e^{it} \cdot x = x, \quad \forall t \in \mathbb{R}\}.$$

Then the kernel and cokernel of the morphism $i^ : H_{S^1}^\bullet(M) \rightarrow H_{S^1}^\bullet(F)$ are negligible $\mathbb{C}[z]$ -modules. In particular,*

$$\operatorname{rank}_{\mathbb{C}[z]} H_{S^1}^\pm(M) = \dim_{\mathbb{C}} H^\pm(F), \quad (3.20)$$

where for any topological space X we set

$$H^\pm(X) := \bigoplus_{k=\text{even/odd}} H^k(X).$$

Proof. We follow [AB2], which is in essence a geometrical translation of the spectral sequence argument employed in [Bo, Hs]. We equip M with an S^1 -invariant metric, so that S^1 acts by isometries. Arguing as in the proof of Lemma 3.39, we deduce that F is a (possibly disconnected) smooth submanifold of M . To proceed further we need to use the following elementary facts.

Lemma 3.65. *(a) If $A \xrightarrow{f} B \xrightarrow{g} C$ is an exact sequence of finitely generated $\mathbb{C}[z]$ -modules, then*

$$\operatorname{supp} B \subset \operatorname{supp} A \cup \operatorname{supp} C. \quad (3.21)$$

In particular, if the sequence $0 \rightarrow A \rightarrow B \rightarrow C \rightarrow 0$ is exact and two of the three modules in it are negligible, then so is the third.

(b) Suppose $f : X \rightarrow Y$ is an equivariant map between S^1 -spaces of finite type such that Y is negligible. Then X is negligible as well. In particular, if X is a finite type S^1 -space that admits an S^1 -map $f : X \rightarrow [S^1, k]$, $k > 0$, then X is negligible.

(c) Any finite type invariant subspace of a negligible S^1 -space is negligible.

(d) If U and V are negligible invariant open subsets of an S^1 space, then their union is also negligible.

Proof. Part (a) is a special case of a classical fact of commutative algebra, [S, I.5]. For the reader's convenience we present the simple proof of this special case.

Clearly the inclusion (3.21) is trivially satisfied when either A_{free} or C_{free} is nontrivial. Thus assume $A = A_{\text{tors}}$ and $C = C_{\text{tors}}$. Observe that we have a short exact sequence

$$0 \rightarrow \ker f \rightarrow B \rightarrow \text{Im } g \rightarrow 0. \quad (3.22)$$

Note that $\text{supp } \ker f \subset \text{supp } A$ and $\text{supp } \text{Im } g \subset \text{supp } C$. We then have an isomorphism of vector spaces

$$B \cong \ker f \oplus \text{Im } g.$$

Denote by α_z the linear map induced by multiplication by z on $\ker f$, by β_z the linear map induced on B , and by γ_z the linear map induced on $\text{Im } g$. Using the exactness (3.22) we deduce that β_z , regarded as a \mathbb{C} -linear endomorphism of $\ker f \oplus \text{Im } g$, has the upper triangular block decomposition

$$\beta_z = \begin{bmatrix} \alpha_z & * \\ 0 & \gamma_z \end{bmatrix},$$

where $*$ denotes a linear map $\text{Im } g \rightarrow \ker f$. Then

$$\det(\lambda \mathbb{1} - \beta_z) = \det(\lambda \mathbb{1} - \alpha_z) \det(\lambda \mathbb{1} - \gamma_z),$$

which shows that

$$\text{supp } B = \text{supp } \ker f \cup \text{supp } \text{Im } g \subset \text{supp } A \cup \text{supp } C.$$

(b) Consider an S^1 -map $f : X \rightarrow Y$. Note that $c_X = c_Y \circ f$, and we have a sequence

$$\mathbb{C}[\tau] = H_{S^1}^\bullet(*) \xrightarrow{c_Y^*} H_{S^1}^\bullet(Y) \xrightarrow{f^*} H_{S^1}^\bullet(X).$$

On the other hand, since $\text{supp } H_{S^1}^\bullet(Y) = \{0\}$, we deduce that $c_Y^*(\tau)^n = 0$ for some positive integer n . We deduce that $c_X^*(\tau) = 0$, so that $\text{supp } H_{S^1}^\bullet(X) = \{0\}$. If $Y = [S^1, k]$, then we know from Example 3.61(c) that $\text{supp } H_{S^1}^\bullet(Y) = \{0\}$.

(c) If U is an invariant subset of the negligible S^1 -space X , then applying (b) to the inclusion $U \hookrightarrow X$ we deduce that U is negligible.

(d) Finally, if U, V are negligible invariant open subsets of the S^1 -space X , then the Mayer–Vietoris sequence yields the exact sequence

$$H_{S^1}^{\bullet-1}(U \cap V) \rightarrow H_{S^1}^{\bullet}(U \cup V) \rightarrow H_{S^1}^{\bullet}(U) \oplus H_{S^1}^{\bullet}(V).$$

Part (c) shows that $U \cap V$ is negligible. The claim now follows from (a). \square

Our next result will use Lemma 3.65 to produce a large supply of negligible invariant subsets of M .

Lemma 3.66. *Suppose that the stabilizer of $x \in M$ is the finite cyclic group \mathbb{Z}/k . Then for any open neighborhood U of the orbit \mathcal{O}_x of x there exists an open S^1 -invariant neighborhood U_x of \mathcal{O}_x contained in U that is of finite type and is equipped with an S^1 -map $f : U_x \rightarrow [S^1, k]$. In particular, U_x is negligible.*

Proof. Fix an S^1 -invariant metric g on M . The orbit \mathcal{O}_x of x is equivariantly diffeomorphic to $[S^1, k]$. For $r > 0$ we set

$$U_x(r) = \{y \in M; \text{dist}(y, \mathcal{O}_x) < r\}.$$

Since S^1 acts by isometries, $U_x(r)$ is an open S^1 -invariant set.

For every $y \in \mathcal{O}_x$ we denote by $T_y \mathcal{O}_x^\perp$ the orthogonal complement of $T_y \mathcal{O}_x$ in $T_y M$. We thus obtain a vector bundle $T \mathcal{O}_x^\perp \rightarrow \mathcal{O}_x$. Denote by D_r^\perp the associated bundle of open disks of radius r . If $r > 0$ is sufficiently small then the exponential map determined by the metric g defines a diffeomorphism

$$\exp : D_r^\perp \rightarrow U_x(r).$$

In this case, arguing exactly as in the proof of the classical Gauss lemma in Riemannian geometry (see [Ni, Lemma 4.1.22]), we deduce that for every $y \in U_x(r)$ there exists a unique $\pi(y) \in \mathcal{O}_x$ such that

$$\text{dist}(y, \pi(y)) = \text{dist}(y, \mathcal{O}_x).$$

The resulting map $\pi : U_x(r) \rightarrow \mathcal{O}_x = [S^1, k]$ is continuous and equivariant. Clearly, $U_x(r)$ is of finite type for $r > 0$ sufficiently small, and for every neighborhood U of \mathcal{O}_x we can find $r > 0$ such that $U_x(r) \subset U$. \square

Remark 3.67. Observe that the assumption that the stabilizer of a point x is finite is equivalent to the fact that x is not a fixed point of the S^1 -action. \square

For every $\varepsilon > 0$ sufficiently small we define the S^1 -invariant subset of M

$$\bar{M}_\varepsilon := \{y \in M; \text{dist}(y, F) \geq \varepsilon\}, \quad U_\varepsilon = M \setminus \bar{M}_\varepsilon.$$

Observe that \bar{M}_ε is the complement of an open thin tube U_ε around the fixed point set F .

Lemma 3.68. *For all $\varepsilon > 0$ sufficiently small, the set \bar{M}_ε is negligible.*

Proof. Cover \bar{M}_ε by finitely many negligible open sets of the type U_x described in Lemma 3.66. Denote them by U_1, \dots, U_ν . Proposition 3.63 implies that $V_i = U_i \cap \bar{M}_\varepsilon$ is of finite type and we deduce from Lemma 3.65 and Lemma 3.66 that

$$\text{supp } H_{S^1}^\bullet(V_i) = \text{supp } H_{S^1}^\bullet(U_1) = \{0\}.$$

Now define recursively

$$W_1 = U_1, \quad W_{i+1} = W_i \cup V_{i+1}, \quad 1 \leq i < \nu.$$

Using Lemma 3.65(d) we deduce inductively that \bar{M}_ε is negligible. \square

Observe that the natural morphism $H_{S^1}^\bullet(U_\varepsilon) \rightarrow H_{S^1}^\bullet(F)$ is an isomorphism for all $\varepsilon > 0$ sufficiently small, so we need to understand the kernel and cokernel of the map

$$H_{S^1}^\bullet(M) \rightarrow H_{S^1}^\bullet(U_\varepsilon).$$

The long exact sequence of the pair (M, U_ε) shows that these are submodules of $H_{S^1}^\bullet(M, U_\varepsilon)$. Thus, it suffices to show that $H_{S^1}^\bullet(M, U_\varepsilon)$ is a negligible $\mathbb{C}[z]$ -module. By excision we have

$$H_{S^1}^\bullet(M, U_\varepsilon) = H_{S^1}^\bullet(\bar{M}_\varepsilon, \partial\bar{M}_\varepsilon).$$

Lemma 3.65(c) implies that $\partial\bar{M}_\varepsilon$ is negligible.

Using the long exact sequence of the pair $(\bar{M}_\varepsilon, \partial\bar{M}_\varepsilon)$ we obtain an exact sequence

$$H_{S^1}^\mp(\partial\bar{M}_\varepsilon) \rightarrow H_{S^1}^\pm(\bar{M}_\varepsilon, \partial\bar{M}_\varepsilon) \rightarrow H_{S^1}^\pm(\bar{M}_\varepsilon).$$

Since the two extremes of this sequence are negligible, we deduce from Lemma 3.65(a) that the middle module is negligible as well. This proves that both the kernel and the cokernel of the morphism $H_{S^1}^\bullet(M) \rightarrow H_{S^1}^\bullet(F)$ are negligible $\mathbb{C}[z]$ -modules.

On the other hand, according to Example 3.61(d), the $\mathbb{C}[z]$ -module $H_{S^1}^\bullet(F)$ is free and thus

$$\ker\left(H_{S^1}^\bullet(M) \rightarrow H_{S^1}^\bullet(F)\right) = H_{S^1}^\bullet(M)_{\text{tors}}.$$

We thus have an injective map $H_{S^1}^\bullet(M)_{\text{free}} \rightarrow H_{S^1}^\bullet(F)$ whose cokernel is a torsion module. We deduce that

$$\text{rank}_{\mathbb{C}[z]} H_{S^1}^\pm(M) = \text{rank}_{\mathbb{C}[z]} H_{S^1}^\pm(F) = \dim_{\mathbb{C}} H^\pm(F). \quad \square$$

From the localization theorem we deduce the following result of P. Conner [Co]. For a different approach we refer to [Bo, IV.5.4].

Corollary 3.69. *Suppose the torus \mathbb{T} acts on the compact smooth manifold M . Let M and F be as in Theorem 3.64. Then*

$$\dim_{\mathbb{C}} H^{\pm}(M) \geq \dim_{\mathbb{C}} H^{\pm}(\text{Fix}_{\mathbb{T}}(M)). \quad (3.23)$$

Proof. We will argue by induction on $\dim \mathbb{T}$. To start the induction, assume first that $\mathbb{T} = S^1$. Consider the S^1 -bundle $P_M = S^{\infty} \times M \rightarrow M_{S^1}$. Since S^{∞} is contractible the Gysin sequence of this S^1 -bundle can be rewritten as

$$\cdots \rightarrow H^{\bullet}(M) \rightarrow H_{S^1}^{\bullet-1}(M) \xrightarrow{z \cup} H_{S^1}^{\bullet+1}(M) \rightarrow H^{\bullet+1}(M) \rightarrow \cdots .$$

In particular we deduce that we have an injection

$$H_{S^1}^{\pm}(M)/zH_{S^1}^{\pm}(M) \hookrightarrow H^{\pm}(M).$$

Using a (noncanonical) direct sum decomposition

$$H_{S^1}^{\pm}(M) = H_{S^1}^{\pm}(M)_{\text{tors}} \oplus H_{S^1}^{\pm}(M)_{\text{free}}$$

we obtain an injection

$$H_{S^1}^{\pm}(M)_{\text{free}}/zH_{S^1}^{\pm}(M)_{\text{free}} \hookrightarrow H^{\pm}(M).$$

The above quotient is a finite dimensional complex vector space of dimension equal to the rank of $H_{S^1}^{\pm}(M)$, and from the localization theorem we deduce

$$\begin{aligned} \dim_{\mathbb{C}} H^{\pm}(F) &= \dim_{\mathbb{C}} H_{S^1}^{\pm}(M)_{\text{free}}/zH_{S^1}^{\pm}(M)_{\text{free}} \\ &\leq \dim_{\mathbb{C}} H^{\pm}(M) = \dim_{\mathbb{C}} H^{\pm}(M). \end{aligned}$$

□

Suppose now that \mathbb{T} is an n -dimensional torus such that $\mathbb{T}' = \mathbb{T} \times S^1$ acts on M . Let F' denote the fixed point set of \mathbb{T}' and let F denote the fixed point set of \mathbb{T} . They are both submanifolds of M and $F' \subset F$. The component S^1 acts on F , and we have

$$F' = \text{Fix}_{S^1}(F).$$

The induction hypothesis implies

$$\dim_{\mathbb{C}} H^{\pm}(M) \geq \dim_{\mathbb{C}} H^{\pm}(F),$$

while the initial step of the induction shows that

$$\dim_{\mathbb{C}} H^{\pm}(F) \geq \dim_{\mathbb{C}} H^{\pm}(\text{Fix}_{S^1}(F)) = \dim_{\mathbb{C}} H^{\pm}(F'). \quad \square$$

Theorem 3.70. *Suppose (M, ω) is a compact symplectic manifold equipped with a Hamiltonian action of a torus \mathbb{T} with moment map $\mu : M \rightarrow \mathfrak{t}^*$. Then for every $X \in \mathfrak{t}$ the function $\xi_X : M \rightarrow \mathbb{R}$ given by $\xi_X(x) = \langle \mu(x), X \rangle$, $x \in M$, is a perfect Morse–Bott function.*

Proof. We use the strategy in [Fra]. We already know from Theorem 3.37 that ξ_X is a Morse–Bott function. Moreover, its critical set is the fixed point set F of the closed torus $\mathbb{T}_X \subset \mathbb{T}$ generated by e^{tX} . Denote by $\{F_\alpha\}$ the connected components of this fixed point set and by λ_α the Morse index of the critical submanifold F_α . We then have the Morse–Bott inequalities

$$\sum_{\alpha} t^{\lambda_{\alpha}} P_{C_{\alpha}}(t) \succ P_M(t). \quad (3.24)$$

If we set $t = 1$ we deduce

$$\sum_k b_k(F) = \sum_{\alpha} \sum_k b_k(F_{\alpha}) \geq \sum_k b_k(M). \quad (3.25)$$

The inequality (3.23) shows that we actually have equality in (3.25), and this in turn implies that we have equality in (3.24), i.e., f is a perfect Morse–Bott function. \square

Remark 3.71. (a) The perfect Morse–Bott functions on complex Grassmannians used in the proof of Proposition 3.1 are of the type discussed in the above theorem. For a very nice discussion of Morse theory, Grassmannians and equivariant cohomology we refer to the survey paper [Gu]. For more refined applications of equivariant cohomology to Morse theory we refer to [AB1, B2].

(b) In the proof of Theorem 3.70 we have shown that for every Hamiltonian action of a torus \mathbb{T} on a compact symplectic manifold we have

$$\sum_k \dim H^k(\text{Fix}_{\mathbb{T}}(M)) = \sum_k H^k(M).$$

Such actions of \mathbb{T} are called *equivariantly formal* and enjoy many interesting properties. We refer to [Bo, XII] and [GKM] for more information on these types of actions. \square

Basics of Complex Morse Theory

In this final chapter we would like to introduce the reader to the complex version of Morse theory that has proved to be very useful in the study of the topology of complex projective varieties, and more recently in the study of the topology of symplectic manifolds.

The philosophy behind complex Morse theory is the same as that for the real Morse theory we have investigated so far. Given a complex submanifold M of a projective space $\mathbb{C}\mathbb{P}^N$ we consider a (complex) 1-dimensional family of (projective) hyperplanes H_t , $t \in \mathbb{C}\mathbb{P}^1$ and we study the family of slices $H_t \cap M$. These slices are in fact the fibers of a holomorphic map $f : M \rightarrow \mathbb{C}\mathbb{P}^1$.

In this case the “time variable” is complex, and we cannot speak of sublevel sets. However, the whole setup is much more rigid, since all the objects involved are holomorphic, and we can still extract nontrivial information about the family of slices $H_t \cap M$ from a finite collection of data, namely the behavior of the family near the singular slices, i.e., near those parameters τ such that H_τ does not intersect M transversally.

In the complex case the parameter t can approach a singular value τ in a more sophisticated way, and the right information is no longer contained in one number (index of a Hessian) but in a morphism of groups called monodromy, which encodes how the homology of a slice $H_t \cap M$ changes as t moves around a small loop surrounding a singular value τ .

We can then use this local information to obtain surprising results relating the topology of M to the topology of a generic slice $H_t \cap M$ and the singularities of the family.

To ease notation, in this chapter we will write \mathbb{P}^N instead of $\mathbb{C}\mathbb{P}^N$. For every complex vector space V we will denote by $\mathbb{P}(V)$ its projectivization, i.e., the space of complex one dimensional subspaces in V . Thus $\mathbb{P}^N = \mathbb{P}(\mathbb{C}^{N+1})$. The dual of $\mathbb{P}(V)$ is $\mathbb{P}(V^*)$, and it parametrizes the (projective) hyperplanes in $\mathbb{P}(V)$. We will denote the dual of $\mathbb{P}(V)$ by $\check{\mathbb{P}}(V)$.

We will denote by $\mathcal{P}_{d,N}$ the vector space of homogeneous complex polynomials of degree d in the variables z_0, \dots, z_N . Note that

$$\dim_{\mathbb{C}} \mathcal{P}_{d,N} = \binom{d+N}{d}.$$

We denote by $\mathbb{P}(d, N)$ the projectivization of $\mathcal{P}_{d,N}$. Observe that $\mathbb{P}(1, N) = \mathbb{P}^N$.

4.1 Some Fundamental Constructions

Loosely speaking, a *linear system* on a complex manifold is a holomorphic family of divisors (i.e., complex hypersurfaces) parametrized by a projective space. Instead of a formal definition we will analyze a special class of examples. For more information we refer to [GH].

Suppose $X \hookrightarrow \mathbb{P}^N$ is a compact submanifold of dimension n . Each polynomial $P \in \mathcal{P}_{d,N} \setminus \{0\}$ determines a (possibly singular) hypersurface

$$\mathcal{Z}_P := \left\{ [z_0 : \dots : z_N] \in \mathbb{P}^N; P(z_0, \dots, z_N) = 0 \right\}.$$

The intersection $X_P := X \cap \mathcal{Z}_P$ is a degree d hypersurface (thus a divisor) on X . Observe that \mathcal{Z}_P and X_P depend only on the image $[P]$ of P in the projectivization $\mathbb{P}(d, N)$ of $\mathcal{P}_{d,N}$.

Each projective subspace $U \subset \mathbb{P}(d, N)$ defines a family $(X_P)_{[P] \in U}$ of hypersurfaces on X . This is a *linear system*.¹ When $\dim U = 1$, i.e., U is a projective line, we say that the family $(X_P)_{P \in U}$ is a *pencil*. The intersection

$$B = B_U := \bigcap_{P \in U} X_P$$

is called the *base locus* of the linear system. The points in B are called *base points*.

Any point $x \in X \setminus B$ determines a hyperplane $H_x \subset U$ described by the equation

$$H_x := \{ P \in U; P(x) = 0 \}.$$

The hyperplane H_x determines a point in the dual projective space \check{U} . (Observe that if U is 1-dimensional then $U = \check{U}$.)

We see that a linear system determines a holomorphic map

$$f_U : X^* := X \setminus B \rightarrow \check{U}, \quad x \mapsto H_x.$$

We define the *modification of X* determined by the linear system $(X_P)_{P \in U}$ to be the variety

$$\hat{X} = \hat{X}_U = \left\{ (x, H) \in X \times \check{U}; P(x) = 0, \quad \forall P \in H \subset U \right\}.$$

¹ To be accurate, what we call a linear system is what algebraic geometers refer to as an *ample* linear system.

Equivalently, the modification of X determined by the linear system is the closure in $X \times \check{U}$ of the graph of f_U . Very often, B and \hat{X}_U are not smooth objects.

When $\dim U = 1$ the modification has the simpler description

$$\hat{X} = \hat{X}_U = \left\{ (x, P) \in X \times U; x \in \mathcal{Z}_P \right\}.$$

We have a pair of holomorphic maps π_X and \hat{f}_U induced by the natural projections:

$$\begin{array}{ccc} & \hat{X}_U \subset X \times \check{U} & \\ \pi_X \swarrow & & \searrow \hat{f}_U \\ X & \overset{f_U}{\dashrightarrow} & \check{U} \end{array}$$

When $\dim U = 1$ the map $\hat{f} : \hat{X} \rightarrow \check{U}$ can be regarded as a map to U .

The projection π_X induces a biholomorphic map $\hat{X}^* := \pi_X^{-1}(X^*) \rightarrow X^*$ and we have a commutative diagram

$$\begin{array}{ccc} & \hat{X}^* & \\ \pi_X \swarrow & & \searrow \hat{f}_U \\ X^* & \xrightarrow{f_U} & \check{U} \end{array}$$

Remark 4.1. When studying linear systems defined by projective subspaces $U \subset \mathbb{P}(d, N)$ it suffices to consider only the case $d = 1$, i.e. linear systems of hyperplanes.

To see this, define for $\mathbf{z} \in \mathbb{C}^{N+1} \setminus \{0\}$ and $\omega = (\omega_0, \dots, \omega_N) \in \mathbb{Z}_+^{N+1}$

$$|\omega| = \sum_{i=0}^N \omega_i, \quad \mathbf{z}^\omega = \prod_{i=0}^N z_i^{\omega_i} \in \mathcal{P}_{|\omega|, N}.$$

Any $P = \sum_{|\omega|=d} p_\omega \mathbf{z}^\omega \in \mathcal{P}_{d, N}$ defines a hyperplane in $\check{\mathbb{P}}(d, N)$,

$$H_P = \left\{ [z_\omega] \in \check{\mathbb{P}}(d, N); \sum_{|\omega|=d} p_\omega z_\omega = 0 \right\}.$$

We have the *Veronese embedding*

$$\mathbf{V}_{d, N} : \mathbb{P}^N \hookrightarrow \check{\mathbb{P}}(d, N), \quad [\mathbf{z}] \mapsto [(z_\omega)] := [(\mathbf{z}^\omega)_{|\omega|=d}]. \tag{4.1}$$

Observe that $\mathbf{V}(\mathcal{Z}_P) \subset H_P$, so that $\mathbf{V}(X \cap \mathcal{Z}_P) = \mathbf{V}(X) \cap H_P$. □

Definition 4.2. A Lefschetz pencil on $X \hookrightarrow \mathbb{P}^N$ is a pencil determined by a one dimensional projective subspace $U \hookrightarrow \mathbb{P}(d, N)$ with the following properties.

- (a) The base locus B is either empty or it is a smooth, complex codimension two submanifold of X .
- (b) \hat{X} is a smooth manifold.
- (c) The holomorphic map $\hat{f} : \hat{X} \rightarrow U$ is a nonresonant Morse function, i.e., no two critical points correspond to the same critical value and for every critical point x_0 of \hat{f} there exist holomorphic coordinates (z_j) near x_0 and a holomorphic coordinate u near $\hat{f}(x_0)$ such that

$$u \circ \hat{f} = \sum_j z_j^2.$$

The map $\hat{X} \rightarrow S$ is called the Lefschetz fibration associated with the Lefschetz pencil. If the base locus is empty, $B = \emptyset$, then $\hat{X} = X$ and the Lefschetz pencil is called a Lefschetz fibration. \square

We have the following genericity result. Its proof can be found in [Lam, Section 2].

Theorem 4.3. Fix a compact complex submanifold $X \hookrightarrow \mathbb{P}^N$. Then for any generic projective line $U \subset \mathbb{P}(d, N)$, the pencil $(X_P)_{P \in U}$ is Lefschetz. \square

According to Remark 4.1, it suffices to consider only pencils generated by degree 1 polynomials. In this case, the pencils can be given a more visual description.

Suppose $X \hookrightarrow \mathbb{P}^N$ is a compact complex manifold. Fix a codimension two projective subspace $A \hookrightarrow \mathbb{P}^N$ called the *axis*. The hyperplanes containing A form a one dimensional projective space $U \subset \mathbb{P}^N \cong \mathbb{P}(1, N)$. It can be identified with any line in \mathbb{P}^N that does not intersect A . Indeed, if S is such a line (called a *screen*), then any hyperplane H containing A intersects S in a single point $s(H)$. We have thus produced a map

$$U \ni H \mapsto s(H) \in S.$$

Conversely, any point $s \in S$ determines a unique hyperplane $[As]$ containing A and passing through s . The correspondence

$$S \ni s \mapsto [As] \in U$$

is the inverse of the above map; see Figure 4.1.

The base locus of the linear system

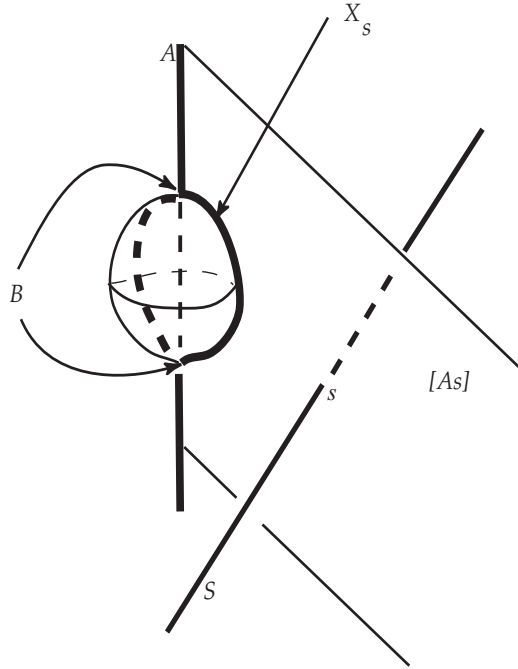

Fig. 4.1. Projecting onto the “screen” S .

$$(X_s = [As] \cap X)_{s \in S}$$

is $B = X \cap A$. All the hypersurfaces X_s pass through the base locus B . For generic A this is a smooth codimension 2 submanifold of X . We have a natural map

$$f : X \setminus B \rightarrow S, \quad X \setminus Bx \mapsto S \cap [Ax] \in S.$$

We can now define the elementary modification of X to be the incidence variety

$$\hat{X} := \{(x, s) \in X \times S; x \in X_s\}.$$

The critical points of \hat{f} correspond to the hyperplanes through A that contain a tangent (projective) plane to X . We have a diagram

$$\begin{array}{ccc} & \hat{X} & \\ \pi \swarrow & & \searrow \hat{f} \\ X & \overset{f}{\dashrightarrow} & S \end{array}$$

We define $\hat{B} := \pi^{-1}(B)$. Observe that

$$\hat{B} = \{(b, s) \in B \times S; b \in [As]\} = B \times S,$$

and the natural projection $\pi : \hat{B} \rightarrow B$ coincides with the projection $B \times S \rightarrow B$. Set $\hat{X}_s := \hat{f}^{-1}(s)$.

The projection π induces a homeomorphism $\hat{X}_s \rightarrow X_s$.

Example 4.4 (Pencils of lines). Suppose X is the projective plane

$$\{z_3 = 0\} \cong \mathbb{P}^2 \hookrightarrow \mathbb{P}^3.$$

Assume A is the line $z_1 = z_2 = 0$ and S is the line $z_0 = z_3 = 0$. The base locus consists of the single point $B = [1 : 0 : 0 : 0] \in X$. The pencil obtained in this fashion consists of all lines passing through B .

Observe that $S \subset X \cong \mathbb{P}^2$ can be identified with the line at ∞ in \mathbb{P}^2 . The map $f : X \setminus \{B\} \rightarrow S$ determined by this pencil is simply the projection onto the line at ∞ with center B . The modification of X defined by this pencil is called the *blowup* of \mathbb{P}^2 at B . \square

Example 4.5 (Pencils of cubics). Consider two homogeneous cubic polynomials $A, B \in \mathcal{P}_{3,2}$ (in the variables z_0, z_1, z_2). For generic A, B these are smooth cubic curves in \mathbb{P}^2 . (The genus formula in Corollary 4.14 will show that they are homeomorphic to tori.) By Bézout's theorem, these two general cubics meet in 9 distinct points, p_1, \dots, p_9 . For $\mathbf{t} := [t_0 : t_1] \in \mathbb{P}^1$ set

$$C_{\mathbf{t}} := \{[z_0 : z_1 : z_2] \in \mathbb{P}^2; t_0 A(z_0, z_1, z_2) + t_1 B(z_0, z_1, z_2) = 0\}.$$

The family $C_{\mathbf{t}}$, $\mathbf{t} \in \mathbb{P}^1$, is a pencil on $X = \mathbb{P}^2$. The base locus of this system consists of the nine points p_1, \dots, p_9 common to all these cubics. The modification

$$\hat{X} := \left\{ ([z_0, z_1, z_2], \mathbf{t}) \in \mathbb{P}^2 \times \mathbb{P}^1; t_0 A(z_0, z_1, z_2) + t_1 B(z_0, z_1, z_2) = 0 \right\}$$

is isomorphic to the blowup of X at these nine points,

$$\hat{X} \cong \hat{X}_{p_1, \dots, p_9}.$$

For general A, B the induced map $\hat{f} \rightarrow \mathbb{P}^1$ is a Morse map, and its generic fiber is an elliptic curve. The manifold \hat{X} is a basic example of an *elliptic fibration*. It is usually denoted by $E(1)$. \square

4.2 Topological Applications of Lefschetz Pencils

All of the results in this section originate in the remarkable work of S. Lefschetz [Lef] in the 1920s. We follow the modern presentation in [Lam]. In this section, unless otherwise stated, $H_{\bullet}(X)$ (respectively $H^{\bullet}(X)$) will denote the *integral* singular homology (respectively cohomology) of the space X .

Before we proceed with our study of Lefschetz pencils we want to mention two important results, frequently used in the sequel. The first one is called the *Ehresmann fibration theorem* [Ehr].

Theorem 4.6. *Suppose $\Phi : E \rightarrow B$ is a smooth map between two smooth manifolds such that*

- Φ is proper, i.e., $\Phi^{-1}(K)$ is compact for every compact $K \subset B$.
- Φ is a submersion.
- If $\partial E \neq \emptyset$ then the restriction $\partial\Phi$ of Φ to ∂E continues to be a submersion.

Then $\Phi : (E, \partial E) \rightarrow B$ is a locally trivial, smooth fiber bundle. \square

The second result needed in the sequel is a version of the excision theorem for singular homology, [Spa, Theorems 6.6.5 and 6.1.10].

Theorem 4.7 (Excision). *Suppose $f(X, A) \rightarrow (Y, B)$ is a continuous mapping between compact ENR pairs² such that*

$$f : X \setminus A \rightarrow Y \setminus B$$

is a homeomorphism. Then f induces an isomorphism

$$f_* : H_\bullet(X, A; \mathbb{Z}) \rightarrow H_\bullet(Y, B; \mathbb{Z}). \quad \square$$

Remark 4.8. For every compact oriented, m -dimensional manifold M denote by PD_M the Poincaré duality map

$$H^q(M) \rightarrow H_{m-q}(M), \quad u \mapsto u \cap [M].$$

The sign conventions for the \cap -product follow from the definition

$$\langle v \cup u, c \rangle = \langle v, u \cap c \rangle,$$

where $\langle -, - \rangle$ denotes the Kronecker pairing between singular cochains and chains.

Observe that if $f : X \rightarrow Y$ is a continuous map between topological spaces, then for every chain c in X and cochains u, v in Y ,

$$\begin{aligned} \langle v, u \cap p_*(c) \rangle &= \langle u \cup v, p_*(c) \rangle = \langle p^*(u) \cup p^*(v), c \rangle \\ &= \langle p^*(v), p^*(u) \cap c \rangle = \langle v, p_*(p^*(u) \cap c) \rangle, \end{aligned}$$

so that we obtain the *projection formula*

$$p_*(p^*(u) \cap c) = u \cap p_*(c). \quad (4.2)$$

\square

Suppose $X \hookrightarrow \mathbb{P}^N$ is an n -dimensional algebraic manifold, and $S \subset \mathbb{P}(d, N)$ is a one dimensional projective subspace defining a Lefschetz pencil $(X_s)_{s \in S}$ on X . As usual, denote by B the base locus

² E.g., (X, A) is a compact ENR pair if X is a compact CW -complex and A is a subcomplex.

$$B = \bigcap_{s \in S} X_s$$

and by \hat{X} the modification

$$\hat{X} = \left\{ (x, s) \in X \times S; x \in X_s \right\}.$$

We have an induced *Lefschetz fibration* $\hat{f} : \hat{X} \rightarrow S$ with fibers $\hat{X}_s := \hat{f}^{-1}(s)$, and a surjection $p : \hat{X} \rightarrow X$ that induces homeomorphisms $\hat{X}_s \rightarrow X_s$. Observe that $\deg p = 1$. Set

$$\hat{B} := p^{-1}(B).$$

We have a tautological diffeomorphism

$$\hat{B} \cong B \times S, \quad \hat{B} \ni (x, s) \mapsto (x, s) \in B \times S.$$

Since $S \cong S^2$ we deduce from Künneth's theorem that we have an isomorphism

$$H_q(\hat{B}) \cong H_q(B) \oplus H_{q-2}(B)$$

and a natural injection

$$H_{q-2}(B) \rightarrow H_q(\hat{B}), \quad H_{q-2}(B) \ni c \mapsto c \times [S] \in H_q(\hat{B}).$$

Using the inclusion map $\hat{B} \rightarrow \hat{X}$ we obtain a natural morphism

$$\kappa : H_{q-2}(B) \rightarrow H_q(\hat{X}).$$

Lemma 4.9. *The sequence*

$$0 \rightarrow H_{q-2}(B) \xrightarrow{\kappa} H_q(\hat{X}) \xrightarrow{p_*} H_q(X) \rightarrow 0 \quad (4.3)$$

is exact and splits for every q . In particular, \hat{X} is connected iff X is connected and

$$\chi(\hat{X}) = \chi(X) + \chi(B).$$

Proof. The proof will be carried out in several steps.

Step 1 p_* admits a natural right inverse. Consider the Gysin morphism

$$p^! : H_q(X) \rightarrow H_q(\hat{X}), \quad p^! = PD_{\hat{X}} p^* PD_X^{-1},$$

so that the diagram below is commutative:

$$\begin{array}{ccc} H^{2n-q}(X) & \xrightarrow{\cap[X]} & H_q(X) \\ \downarrow p^* & & \downarrow p^! \\ H^{2n-q}(\hat{X}) & \xrightarrow{\cap[\hat{X}]} & H_q(\hat{X}) \end{array}$$

We will show that $p_*p^! = \mathbb{1}$. Let $c \in H_q(X)$ and set $u := PD_X^{-1}(c)$, that is, $u \cap [X] = c$. Then

$$p^!(c) = PD_{\hat{X}}p^*u = p^*(u) \cap [\hat{X}]$$

and

$$p_*p^!(c) = p_*(p^*(u) \cap [\hat{X}]) \stackrel{(4.2)}{=} u \cap p_*([\hat{X}]) = \deg p(u \cap [X]) = c.$$

Step 2. Conclusion. We use the long exact sequences of the pairs (\hat{X}, \hat{B}) , (X, B) and the morphism between them induced by p_* . We have the following commutative diagram:

$$\begin{array}{ccccc} H_{q+1}(\hat{X}) & \longrightarrow & H_{q+1}(\hat{X}, \hat{B}) & \xrightarrow{\partial} & H_q(B) \oplus H_{q-2}(B) \longrightarrow \\ \downarrow p_* & & \downarrow p'_* & & \downarrow \mathbf{pr} \\ H_{q+1}(X) & \longrightarrow & H_{q+1}(X, B) & \xrightarrow{\partial} & H_q(B) \longrightarrow \end{array}$$

$$\begin{array}{ccc} \cdots \longrightarrow H_q(\hat{X}) & \longrightarrow & H_q(\hat{X}, \hat{B}) \\ \downarrow p_* & & \downarrow p'_* \\ \cdots \longrightarrow H_q(X) & \longrightarrow & H_q(X, B) \end{array}$$

The excision theorem shows that the morphisms p'_* are isomorphisms. Moreover, p_* is surjective. The conclusion in the lemma now follows by diagram chasing. \square

Decompose the projective line S into two closed hemispheres

$$S := D_+ \cup D_-, \quad E = D_+ \cap D_-, \quad \hat{X}_{\pm} := \hat{f}^{-1}(D_{\pm}), \quad \hat{X}_E := \hat{f}^{-1}(E)$$

such that all the critical values of $\hat{f} : \hat{X} \rightarrow S$ are contained in the interior of D_+ . Choose a point $*$ on the equator $E = \partial D_+ \cong \partial D_- \cong S^1$. Denote by r the number of critical points (= the number of critical values) of the Morse function \hat{f} . In the remainder of this chapter we will assume the following fact. Its proof is deferred to a later section.

Lemma 4.10.

$$H_q(\hat{X}_+, \hat{X}_*) \cong \begin{cases} 0 & \text{if } q \neq n = \dim_{\mathbb{C}} X, \\ \mathbb{Z}^r & \text{if } q = n. \end{cases}$$

Remark 4.11. The number r of nondegenerate singular points of a Lefschetz pencil defined by *linear polynomials* is a projective invariant of X called the *class* of X . For more information about this projective invariant we refer to [GKZ]. \square

Using the Ehresmann fibration theorem we deduce

$$\hat{X}_- \cong \hat{X}_* \times D_-, \quad \partial\hat{X}_\pm \cong \hat{X}_* \times \partial D_-,$$

so that

$$(\hat{X}_-, \hat{X}_E) \cong \hat{X}_* \times (D_-, E).$$

Clearly, \hat{X}_* is a deformation retract of \hat{X}_- . In particular, the inclusion $\hat{X}_* \hookrightarrow \hat{X}_-$ induces isomorphisms

$$H_\bullet(\hat{X}_*) \cong H_\bullet(\hat{X}_-).$$

Using excision and the Künneth formula we obtain the sequence of isomorphisms

$$H_{q-2}(\hat{X}_*) \xrightarrow{\times[D_-, E]} H_q(\hat{X}_* \times (D_-, E)) \cong H_q(\hat{X}_-, \hat{X}_E) \xrightarrow{\text{excis}} H_q(\hat{X}, \hat{X}_+). \quad (4.4)$$

Consider now the long exact sequence of the triple $(\hat{X}, \hat{X}_+, \hat{X}_*)$,

$$\cdots \rightarrow H_{q+1}(\hat{X}_+, \hat{X}_*) \rightarrow H_{q+1}(\hat{X}, \hat{X}_*) \rightarrow H_{q+1}(\hat{X}, \hat{X}_+) \xrightarrow{\partial} H_q(\hat{X}_+, \hat{X}_*) \rightarrow \cdots.$$

If we use Lemma 4.10 and the isomorphism (4.4) we deduce that we have the isomorphisms

$$L : H_{q+1}(\hat{X}, \hat{X}_*) \rightarrow H_{q-1}(\hat{X}_*), \quad q \neq n, n-1, \quad (4.5)$$

and the 5-term exact sequence

$$\begin{aligned} 0 \rightarrow H_{n+1}(\hat{X}, \hat{X}_*) \rightarrow H_{n-1}(\hat{X}_*) \rightarrow H_n(\hat{X}_+, \hat{X}_*) \rightarrow \\ \rightarrow H_n(\hat{X}, \hat{X}_*) \rightarrow H_{n-2}(\hat{X}_*) \rightarrow 0. \end{aligned} \quad (4.6)$$

Here is a first nontrivial consequence.

Corollary 4.12. *If X is connected and $n = \dim_{\mathbb{C}} X > 1$, then the generic fiber $\hat{X}_* \cong X_*$ is connected.*

Proof. Using (4.5) we obtain the isomorphisms

$$H_0(\hat{X}, \hat{X}_*) \cong H_{-2}(\hat{X}_*) = 0, \quad H_1(\hat{X}, \hat{X}_*) \cong H_{-1}(\hat{X}_*) = 0.$$

Using the long exact sequence of the pair (\hat{X}, \hat{X}_*) we deduce that $H_0(\hat{X}_*) \cong H_0(\hat{X})$. Since X is connected, Lemma 4.9 now implies $H_0(\hat{X}) = 0$, thus proving the corollary. \square

Corollary 4.13.

$$\chi(\hat{X}) = 2\chi(\hat{X}_*) + (-1)^n r, \quad \chi(X) = 2\chi(X_*) - \chi(B) + (-1)^n r.$$

Proof From (4.3) we deduce $\chi(\hat{X}) = \chi(X) + \chi(B)$. On the other hand, the long exact sequence of the pair (\hat{X}, \hat{X}_*) implies

$$\chi(\hat{X}) - \chi(\hat{X}_*) = \chi(\hat{X}, \hat{X}_*).$$

Using (4.5), (4.6), and the Lemma 4.10 we deduce

$$\chi(\hat{X}, \hat{X}_*) = \chi(\hat{X}_*) + (-1)^n r.$$

Thus

$$\chi(\hat{X}) = 2\chi(\hat{X}_*) + (-1)^n r \quad \text{and} \quad \chi(X) = 2\chi(\hat{X}_*) - \chi(B) + (-1)^n r. \quad \square$$

Corollary 4.14 (Genus formula). *For a generic degree d homogeneous polynomial $P \in \mathcal{P}_{d,2}$, the plane curve*

$$C_P := \{ [z_0, z_1, z_2] \in \mathbb{P}^2; P(z_0, z_1, z_2) = 0 \}$$

is a smooth Riemann surface of genus

$$g(C_P) = \frac{(d-1)(d-2)}{2}.$$

Proof Fix a projective line $\mathbb{L} \subset \mathbb{P}^2$ and a point $c \in \mathbb{P}^2 \setminus (C_P \cup \mathbb{L})$. We get a pencil of projective lines $\{[c\ell]; \ell \in \mathbb{L}\}$ and a projection map $f = f_c : C_P \rightarrow \mathbb{L}$, where for every $x \in C_P$ the point $f(x)$ is the intersection of the projective line $[cx]$ with \mathbb{L} . In this case we have no base locus, i.e., $B = \emptyset$ and $X = \hat{X} = V_P$. Since every generic line intersects C_P in d points, we deduce that f is a degree d holomorphic map. A point $x \in C_P$ is a critical point of f_c if and only if the line $[cx]$ is tangent to C_P .

For generic c the projection f_c defines a Lefschetz fibration. Modulo a linear change of coordinates we can assume that all the critical points are situated in the region $z_0 \neq 0$ and c is the point at infinity $[0 : 1 : 0]$.

In the affine plane $z_0 \neq 0$ with coordinates $x = z_1/z_0$, $y = z_2/z_0$, the point $c \in \mathbb{P}^2$ corresponds to the point at infinity on the lines parallel to the x -axis ($y = 0$). In this region the curve C_P is described by the equation

$$F(x, y) = 0,$$

where $F(x, y) = P(1, x, y)$ is a degree d inhomogeneous polynomial.

The critical points of the projection map are the points (x, y) on the curve $F(x, y) = 0$ where the tangent is horizontal,

$$0 = \frac{dy}{dx} = -\frac{F'_x}{F'_y}.$$

Thus, the critical points are solutions of the system of polynomial equations

$$\begin{cases} F(x, y) = 0, \\ F'_x(x, y) = 0. \end{cases}$$

The first polynomial has degree d , while the second polynomial has degree $d - 1$. For generic P this system will have exactly $d(d - 1)$ distinct solutions. The corresponding critical points will be nondegenerate. Using Corollary 4.13 with $X = \hat{X} = C_P$, $r = d(d - 1)$, and X_* a finite set of cardinality d we deduce

$$2 - 2(g(C_P) = \chi(C_P) = 2d - d(d - 1)$$

so that

$$g(C_P) = \frac{(d - 1)(d - 2)}{2}. \quad \square$$

Example 4.15. Consider again two generic cubic polynomials $A, B \in \mathcal{P}_{3,2}$ as in Example 4.5 defining a Lefschetz pencil on $\mathbb{P}^2 \hookrightarrow \mathbb{P}^3$. We can use the above Corollary 4.13 to determine the number r of singular points of this pencil. More precisely, we have

$$\chi(\mathbb{P}^2) = 2\chi(X_*) - \chi(B) + r.$$

We have seen that B consists of 9 distinct points. The generic fiber is a degree 3 plane curve, so by the genus formula it must be a torus. Hence $\chi(X_*) = 0$. Finally, $\chi(\mathbb{P}^2) = 3$. We deduce $r = 12$, so that the generic elliptic fibration $\hat{\mathbb{P}}^2_{p_1, \dots, p_9} \rightarrow \mathbb{P}^1$ has 12 singular fibers. \square

We can now give a new proof of the Lefschetz hyperplane theorem.

Theorem 4.16. *Suppose $X \subset \mathbb{P}^N$ is a smooth projective variety of (complex) dimension n . Then for any hyperplane $H \subset \mathbb{P}^N$ intersecting X transversally the inclusion $X \cap H \hookrightarrow X$ induces isomorphisms*

$$H_q(X \cap H) \rightarrow H_q(X)$$

if $q < \frac{1}{2} \dim_{\mathbb{R}}(X \cap H) = n - 1$ and an epimorphism if $q = n - 1$. Equivalently, this means that

$$H_q(X, X \cap H) = 0, \quad \forall q \leq n - 1.$$

Proof. Choose a codimension two projective subspace $A \subset \mathbb{P}^N$ such that the pencil of hyperplanes in \mathbb{P}^N containing A defines a Lefschetz pencil on X . Then the base locus $B = A \cap X$ is a smooth codimension two complex submanifold of X and the modification \hat{X} is smooth as well.

A transversal hyperplane section $X \cap H$ is diffeomorphic to a generic divisor X_* of the Lefschetz pencil, or to a generic fiber \hat{X}_* of the associated Lefschetz fibration $\hat{f} : \hat{X} \rightarrow S$, where S denotes the projective line in $\check{\mathbb{P}}^N = \mathbb{P}(1, N)$ dual to A .

Using the long exact sequence of the pair (X, X_*) we see that it suffices to show that

$$H_q(X, X_*) = 0, \quad \forall q \leq n - 1.$$

We analyze the long exact sequence of the triple $(\hat{X}, \hat{X}_+ \cup \hat{B}, \hat{X}_* \cup \hat{B})$. We have

$$H_q(\hat{X}, \hat{X}_+ \cup \hat{B}) = H_q(\hat{X}, \hat{X}_+ \cup B \times D_-) \stackrel{excis}{\cong} H_q(\hat{X}_-, \hat{X}_E \cup B \times D_-)$$

(use the Ehresmann fibration theorem)

$$\cong H_q((X_*, B) \times (D_-, E)) \cong H_{q-2}(X_*, B).$$

Using the excision theorem again we obtain an isomorphism

$$p_* : H_q(\hat{X}, \hat{X}_* \cup \hat{B}) \cong H_q(X, X_*).$$

Finally, we have an isomorphism

$$H_\bullet(\hat{X}_+ \cup \hat{B}, \hat{X}_* \cup \hat{B}) \cong H_\bullet(\hat{X}_+, \hat{X}_*). \tag{4.7}$$

Indeed, excise $B \times \text{Int}(D_-)$ from both terms of the pair $(\hat{X}_+ \cup \hat{B}, \hat{X}_* \cup \hat{B})$. Then

$$\hat{X}_+ \cup \hat{B} \setminus (B \times \text{Int}(D_-)) = \hat{X}_+,$$

and since $\hat{X}_* \cap \hat{B} = \{*\} \times B$, we deduce

$$\hat{X}_* \cup \hat{B} \setminus (B \times \text{Int}(D_-)) = \hat{X}_* \cup (D_+ \times B).$$

Observe that $\hat{X}_* \cap (D_+ \times B) = \{*\} \times B$ and that $D_+ \times B$ deformation retracts to $\{*\} \times B$. Hence $\hat{X}_* \cup (D_+ \times B)$ is homotopically equivalent to \hat{X}_* thus proving (4.7).

The long exact sequence of the triple $(\hat{X}, \hat{X}_+ \cup \hat{B}, \hat{X}_* \cup \hat{B})$ can now be rewritten

$$\cdots \rightarrow H_{q-1}(X_*, B) \xrightarrow{\partial} H_q(\hat{X}_+, \hat{X}_*) \rightarrow H_q(X, X_*) \rightarrow H_{q-2}(X_*, B) \xrightarrow{\partial} \cdots$$

Using the Lemma 4.10 we obtain the isomorphisms

$$L' : H_q(X, X_*) \rightarrow H_{q-2}(X_*, B), \quad q \neq n, n+1, \quad (4.8)$$

and the 5-term exact sequence

$$\begin{aligned} 0 \rightarrow H_{n+1}(X, X_*) \rightarrow H_{n-1}(X_*, B) \rightarrow H_n(\hat{X}_+, \hat{X}_*) \rightarrow \\ \rightarrow H_n(X, X_*) \rightarrow H_{n-2}(X_*, B) \rightarrow 0. \end{aligned} \quad (\boxtimes)$$

We now argue by induction on n . The result is obviously true for $n = 1$.

For the inductive step, observe first that B is a transversal hyperplane section of X_* , $\dim_{\mathbb{C}} X_* = n - 1$ and thus by induction we deduce that

$$H_q(X_*, B) = 0, \quad \forall q \leq n - 2.$$

Using (4.8) we deduce

$$H_q(X, X_*) \cong H_{q-2}(X_*, B) \cong 0, \quad \forall q \leq n - 1. \quad \square$$

Corollary 4.17. *If X is a hypersurface in \mathbb{P}^n , then*

$$b_k(X) = b_k(\mathbb{P}^n), \quad \forall k \leq n - 2.$$

In particular, if X is a hypersurface in \mathbb{P}^3 , then $b_1(X) = 0$. \square

Consider the connecting homomorphism

$$\partial : H_n(\hat{X}_+, \hat{X}_*) \rightarrow H_{n-1}(\hat{X}_*).$$

Its image

$$\mathbb{V}(X_*) := \partial \left(H_n(\hat{X}_+, \hat{X}_*) \right) = \ker \left(H_{n-1}(\hat{X}_*) \rightarrow H_{n-1}(\hat{X}) \right) \subset H_{n-1}(\hat{X}_*)$$

is called the module of *vanishing*³ *cycles*.

Using the long exact sequences of the pairs (\hat{X}_+, \hat{X}_*) and (X, X_*) and Lemma 4.10 we obtain the following commutative diagram:

$$\begin{array}{ccccccc} H_n(\hat{X}_+, \hat{X}_*) & \xrightarrow{\partial} & H_{n-1}(\hat{X}_*) & \longrightarrow & H_{n-1}(\hat{X}_+) & \longrightarrow & 0 \\ \downarrow p_1 & & \cong \downarrow p_2 & & \cong \downarrow p_3 & & \\ H_n(X, X_*) & \xrightarrow{\partial} & H_{n-1}(X_*) & \longrightarrow & H_{n-1}(X) & \longrightarrow & 0 \end{array}$$

All the vertical morphisms are induced by the map $p : \hat{X} \rightarrow X$. The morphism p_1 is onto because it appears in the sequence (\boxtimes) , where $H_{n-2}(X_*, B) = 0$ by the Lefschetz hyperplane theorem. Clearly p_2 is an isomorphism since p

³ They are called vanishing because they “melt” when pushed inside \hat{X} .

induces a homeomorphism $\hat{X}_* \cong X_*$. Using the refined five lemma [Mac, Lemma I.3.3] we conclude that p_3 is an isomorphism. The above diagram shows that

$$\begin{aligned} \mathbb{V}(X_*) &= \ker\left(i_* : H_{n-1}(X_*) \rightarrow H_{n-1}(X)\right) \\ &= \text{Image}\left(\partial : H_n(X, X_*) \rightarrow H_{n-1}(X_*)\right), \end{aligned} \quad (4.9a)$$

$$\text{rank } H_{n-1}(X_*) = \text{rank } \mathbb{V}(X_*) + \text{rank } H_{n-1}(X). \quad (4.9b)$$

Let us observe that Lemma 4.10 and the universal coefficients theorem implies that

$$H^n(\hat{X}_+, \hat{X}_*) = \text{Hom}\left(H_n(\hat{X}_+, \hat{X}_*), \mathbb{Z}\right).$$

The Lefschetz hyperplane theorem and the universal coefficients theorem show that

$$H^n(X, X_*) = \text{Hom}_{\mathbb{Z}}\left(H_n(X, X_*), \mathbb{Z}\right).$$

We obtain a commutative cohomological diagram with exact rows:

$$\begin{array}{ccccccc} H^n(\hat{X}_+, \hat{X}_*) & \xleftarrow{\delta} & H^{n-1}(\hat{X}_*) & \xleftarrow{\quad} & H^{n-1}(\hat{X}_+) & \xleftarrow{\quad} & 0 \\ \uparrow \text{mono} & & \uparrow \cong & & \uparrow & & \\ H^n(X, X_*) & \xleftarrow{\delta} & H^{n-1}(X_*) & \xleftarrow{i^*} & H^{n-1}(X) & \xleftarrow{\quad} & 0 \end{array}$$

This diagram shows that

$$\begin{aligned} \mathbb{I}(X_*)^\vee &:= \ker\left(\delta : H^{n-1}(\hat{X}_*) \rightarrow H^n(\hat{X}_+, \hat{X}_*)\right) \\ &\cong \ker\left(\delta : H^{n-1}(X_*) \rightarrow H^n(X, X_*)\right) \\ &\cong \text{Im}\left(i^* : H^{n-1}(X) \rightarrow H^{n-1}(X_*)\right). \end{aligned}$$

Define the module of *invariant cycles* to be the Poincaré dual of $\mathbb{I}(X_*)^\vee$,

$$\mathbb{I}(X_*) := \left\{ u \cap [X_*]; \quad u \in \mathbb{I}(X_*)^\vee \right\} \subset H_{n-1}(X_*),$$

or equivalently,

$$\mathbb{I}(X_*) = \text{Image}\left(i^! : H_{n+1}(X) \rightarrow H_{n-1}(X_*)\right), \quad i^! := PD_{X_*} \circ i^* \circ PD_X^{-1}.$$

The last identification can be loosely interpreted as saying that an invariant cycle is a cycle in a generic fiber X_* obtained by intersecting X_* with a cycle on X of dimension $\frac{1}{2} \dim_{\mathbb{R}} X = \dim_{\mathbb{C}} X$. The reason these cycles are called

invariant has to do with the monodromy of the Lefschetz fibration and it is elaborated in greater detail in a later section.

Since i^* is one-to-one on $H^{n-1}(X)$, we deduce $i^!$ is one-to-one, so that

$$\begin{aligned} \text{rank } \mathbb{I}(X_*) &= \text{rank } H_{n+1}(X) = \text{rank } H_{n-1}(X) \\ &= \text{rank } \text{Im} (i_* : H_{n-1}(X_*) \rightarrow H_{n-1}(X)). \end{aligned} \quad (4.10)$$

Using the elementary fact

$$\begin{aligned} \text{rank } H_{n-1}(X_*) &= \text{rank } \ker (H_{n-1}(X_*) \xrightarrow{i_*} H_{n-1}(X)) \\ &\quad + \text{rank } \text{Im} (i_* : H_{n-1}(X_*) \xrightarrow{i_*} H_{n-1}(X)), \end{aligned}$$

we deduce the following result.

Theorem 4.18 (Weak Lefschetz theorem). *For every projective manifold $X \hookrightarrow \mathbb{P}^N$ of complex dimension n and for a generic hyperplane $H \subset \mathbb{P}^N$, the Gysin morphism*

$$i^! : H_{n+1}(X) \rightarrow H_{n-1}(X \cap H)$$

is injective, and we have

$$\text{rank } H_{n-1}(X \cap H) = \text{rank } \mathbb{I}(X \cap H) + \text{rank } \mathbb{V}(X \cap H),$$

where

$$\mathbb{V}(X \cap H) = \ker (H_{n-1}(X \cap H) \rightarrow H_{n-1}(X)), \quad \mathbb{I}(X \cap H) = \text{Image } i^!. \quad \square$$

The module of invariant cycles can be given a more geometric description. Using Lemma 4.10, the universal coefficients theorem, and the equality

$$\mathbb{I}(X_*)^\vee = \ker (\delta : H^{n-1}(\hat{X}_*) \rightarrow H^n(\hat{X}_+, \hat{X}_*)),$$

we deduce

$$\mathbb{I}(X_*)^\vee = \left\{ \omega \in H^{n-1}(\hat{X}_*); \langle \omega, v \rangle = 0, \forall v \in \mathbb{V}(X_*) \right\}.$$

Observe that $n-1 = \frac{1}{2} \dim \hat{X}_*$ and thus the Kronecker pairing on $H_{n-1}(X_*)$ is given by the intersection form. This is nondegenerate by Poincaré duality. Thus

$$\mathbb{I}(X_*) := \left\{ y \in H_{n-1}(X_*); y \cdot v = 0, \forall v \in \mathbb{V}(X_*) \right\}. \quad (4.11)$$

We have thus proved the following fact.

Proposition 4.19. *A middle dimensional cycle on X_* is invariant if and only if its intersection number with any vanishing cycle is trivial.*

4.3 The Hard Lefschetz Theorem

The last theorem in the previous section is only the tip of the iceberg. In this section we delve deeply into the anatomy of an algebraic manifold and try to understand the roots of the weak Lefschetz theorem.

In this section, unless specified otherwise, $H_\bullet(X)$ denotes the homology with coefficients in \mathbb{R} . For every projective manifold $X \hookrightarrow \mathbb{P}^N$ we denote by X' its intersection with a generic hyperplane. Define inductively

$$X^{(0)} = X, \quad X^{(q+1)} := (X^{(q)})', \quad q \geq 0.$$

Thus $X^{(q+1)}$ is a generic hyperplane section of $X^{(q)}$.

Denote by $\omega \in H^2(X)$ the Poincaré dual of the hyperplane section X' , i.e.

$$[X'] = \omega \cap [X].$$

If a cycle $c \in H_q(X)$ is represented by a smooth (real) oriented submanifold of dimension q then its intersection with a generic hyperplane H is a $(q-2)$ -cycle in $X \cap H = X'$. This intuitive operation $c \mapsto c \cap H$ is none other than the Gysin map

$$i^! : H_q(X) \rightarrow H_{q-2}(X')$$

related to $\omega \cap : H_q(X) \rightarrow H_{q-2}(X)$ via the commutative diagram

$$\begin{array}{ccc} H_q(X) & \xrightarrow{i^!} & H_{q-2}(X') \\ & \searrow \omega \cap & \downarrow i_* \\ & & H_{q-2}(X) \end{array}$$

Proposition 4.20. *The following statements are equivalent.*

- HL₁.** $\mathbb{V}(X') \cap \mathbb{I}(X') = 0$.
- HL₂.** $\mathbb{V}(X') \oplus \mathbb{I}(X') = H_{n-1}(X')$
- HL₃.** *The restriction of $i_* : H_{n-1}(X') \rightarrow H_{n-1}(X)$ to $\mathbb{I}(X')$ is an isomorphism.*
- HL₄.** *The map $\omega \cap : H_{n+1}(X) \rightarrow H_{n-1}(X)$ is an isomorphism.*
- HL₅.** *The restriction of the intersection form on $H_{n-1}(X')$ to $\mathbb{V}(X')$ stays non-degenerate.*
- HL₆.** *The restriction of the intersection form to $\mathbb{I}(X')$ stays nondegenerate.*

Proof. • The weak Lefschetz theorem shows that **HL₁** \iff **HL₂**.

• **HL₂** \implies **HL₃**. From the equality

$$\mathbb{V}(X') = \ker\left(i_* : H_{n-1}(X') \rightarrow H_{n-1}(X)\right)$$

and **HL₂** we deduce that the restriction of i_* to $\mathbb{I}(X')$ is an isomorphism onto the image of i_* . On the other hand, the Lefschetz hyperplane theorem shows that the image of i_* is $H_{n-1}(X)$.

- **HL₃ ⇒ HL₄**. Theorem 4.18 shows that $i^! : H_{n+1}(X) \rightarrow H_{n-1}(X')$ is a monomorphism with image $\mathbb{I}(X')$. By **HL₃**, $i_* : \mathbb{I}(X') \rightarrow H_{n-1}(X)$ is an isomorphism, and thus $\omega \cap = i_* \circ i^!$ is an isomorphism.
- **HL₄ ⇒ HL₃** If $i_* \circ i^! = \omega \cap : H_{n+1}(X) \rightarrow H_{n-1}(X)$ is an isomorphism then we conclude that $i_* : \text{Im}(i^!) = \mathbb{I}(X') \rightarrow H_{n-1}(X)$ is onto. Using (4.10) we deduce that $\dim \mathbb{I}(X') = \dim H_{n-1}(X)$, so that $i_* : H_{n-1}(X') \rightarrow H_{n-1}(X)$ must be one-to-one. The Lefschetz hyperplane theorem now implies that i_* is an isomorphism.
- **HL₂ ⇒ HL₅, HL₂ ⇒ HL₆**. This follows from (4.11), which states that $\mathbb{I}(X')$ is the orthogonal complement of $\mathbb{V}(X')$ with respect to the intersection form.
- **HL₅ ⇒ HL₁, HL₆ ⇒ HL₁**. Suppose we have a cycle

$$c \in \mathbb{V}(X') \cap \mathbb{I}(X').$$

Then

$$c \in \mathbb{I}(X') \implies c \cdot v = 0, \quad \forall v \in \mathbb{V}(X'),$$

while

$$c \in \mathbb{V}(X') \implies c \cdot z = 0, \quad \forall z \in \mathbb{I}(X').$$

When the restriction of the intersection to either $\mathbb{V}(X')$ or $\mathbb{I}(X')$ is non-degenerate, the above equalities imply $c = 0$, so that $\mathbb{V}(X') \cap \mathbb{I}(X') = 0$. \square

Theorem 4.21 (The hard Lefschetz theorem). *The equivalent statements **HL₁, ..., HL₆** above are true (for the homology with real coefficients).*

This is a highly nontrivial result. Its complete proof requires sophisticated analytical machinery (Hodge theory) and is beyond the scope of this book. We refer the reader to [GH, Section 0.7] for more details. In the remainder of this section we will discuss other topological facets of this remarkable theorem.

We have a decreasing filtration

$$X = X^{(0)} \supset X' \supset X^{(2)} \supset \dots \supset X^{(n)} \supset \emptyset,$$

so that $\dim_{\mathbb{C}} X^{(q)} = n - q$, and $X^{(q)}$ is a generic hyperplane section of $X^{(q-1)}$. Denote by $\mathbb{I}_q(X) \subset H_{n-q}(X^{(q)})$ the module of invariant cycles

$$\mathbb{I}_q(X) = \text{Image}\left(i^! : H_{n-q+2}(X^{(q-1)}) \rightarrow H_{n-q}(X^{(q)})\right).$$

Its Poincaré dual (in $X^{(q)}$) is

$$\mathbb{I}_q(X)^\vee = \text{Image}\left(i^* : H^{n-q}(X^{(q-1)}) \rightarrow H^{n-q}(X^{(q)})\right) = PD_{X^{(q)}}^{-1}(\mathbb{I}_q(X)).$$

The Lefschetz hyperplane theorem implies that the morphisms

$$i_* : H_k(X^{(q)}) \rightarrow H_k(X^{(j)}), \quad q \geq j, \quad (4.12)$$

are isomorphisms for $k < \dim_{\mathbb{C}} X^{(q)} = (n - q)$. We conclude by duality that

$$i^* : H^k(X^{(j)}) \rightarrow H^k(X^{(q)}), \quad j \leq q,$$

is an isomorphism if $k + q < n$.

Using **HL**₃ we deduce that

$$i_* : \mathbb{I}_q(X) \rightarrow H_{n-q}(X^{(q-1)})$$

is an isomorphism. Using the Lefschetz hyperplane section isomorphisms in (4.12), we conclude that

$$i_* \text{ maps } \mathbb{I}_q(X) \text{ isomorphically onto } H_{n-q}(X). \quad (\dagger)$$

Using the equality

$$\mathbb{I}_q(X)^\vee = \text{Image} (i^* : H^{n-q}(X^{(q-1)}) \rightarrow H^{n-1}(X^{(q)}))$$

and the Lefschetz hyperplane theorem we obtain the isomorphisms

$$H^{n-q}(X) \xrightarrow{i^*} H^{n-q}(X') \xrightarrow{i^*} \dots \xrightarrow{i^*} H^{n-q}(X^{(q-1)}).$$

Using Poincaré duality we obtain

$$i^! \text{ maps } H_{n+q}(X) \text{ isomorphically onto } \mathbb{I}_q(X). \quad (\dagger\dagger)$$

Iterating **HL**₆ we obtain

$$\begin{aligned} \text{The restriction of the intersection form of } H_{n-q}(X) \text{ to } \mathbb{I}_q(X) \\ \text{is nondegenerate.} \end{aligned} \quad (\dagger\dagger\dagger)$$

The isomorphism i_* carries the intersection form on $\mathbb{I}_q(X)$ to a nondegenerate form on $H_{n-q}(X) \cong H_{n+q}(X)$. When $n - q$ is odd this is a skew-symmetric form, and thus the nondegeneracy assumption implies

$$\dim H_{n-q}(X) = \dim H_{n+q}(X) \in 2\mathbb{Z}.$$

We have thus proved the following result.

Corollary 4.22. *The odd dimensional Betti numbers $b_{2k+1}(X)$ of X are even.* □

Remark 4.23. The above corollary shows that not all even dimensional manifolds are algebraic. Take for example $X = S^3 \times S^1$. Using Künneth's formula we deduce

$$b_1(X) = 1.$$

This manifold is remarkable because it admits a complex structure, yet it is not algebraic! As a complex manifold it is known as the *Hopf surface* (see [Ch, Chapter 1]). □

The q th exterior power ω^q is Poincaré dual to the fundamental class

$$[X^{(q)}] \in H_{2n-2q}(X)$$

of $X^{(q)}$. Therefore we have the factorization

$$\begin{array}{ccc} H_k(X) & \xrightarrow{i^!} & H_{k-2q}(X^{(q)}) \\ & \searrow \omega^q \cap & \downarrow i_* \\ & & H_{k-2q}(X) \end{array}$$

Using (††) and (†) we obtain the following generalization of **HL**₄.

Corollary 4.24. *For $q = 1, 2, \dots, n$ the map*

$$\omega^q \cap : H_{n+q}(X) \rightarrow H_{n-q}(X)$$

is an isomorphism. □

Clearly, the above corollary is equivalent to the *hard Lefschetz theorem*. In fact, we can formulate an even more refined version.

Definition 4.25. (a) *An element $c \in H_{n+q}(X)$, $0 \leq q \leq n$, is called primitive if*

$$\omega^{q+1} \cap c = 0.$$

We will denote by $P_{n+q}(X)$ the subspace of $H_{n+q}(X)$ consisting of primitive elements.

(b) *An element $z \in H_{n-q}(X)$ is called effective if*

$$\omega \cap z = 0.$$

We will denote by $E_{n-q}(X)$ the subspace of effective elements. □

Observe that

$$c \in H_{n+q}(X) \text{ is primitive} \iff \omega^q \cap c \in H_{n-q}(X) \text{ is effective.}$$

Roughly speaking, a cycle is effective if it does not intersect the “part at infinity of X ”, $X \cap$ hyperplane.

Theorem 4.26 (Lefschetz decomposition). (a) *Every element $c \in H_{n+q}(X)$ decomposes uniquely as*

$$c = c_0 + \omega \cap c_1 + \omega^2 \cap c_2 + \dots, \quad (4.13)$$

where $c_j \in H_{n+q+2j}(X)$ are primitive elements.

(b) *Every element $z \in H_{n-q}(X)$ decomposes uniquely as*

$$z = \omega^q \cap z_0 + \omega^{q+1} \cap z_1 + \dots, \quad (4.14)$$

where $z_j \in H_{n+q+2j}(X)$ are primitive elements.

Proof. Observe that because the above representations are unique and since

$$(4.14) = \omega^q \cap (4.13),$$

we deduce that Corollary 4.24 is a consequence of the Lefschetz decomposition.

Conversely, let us show that (4.13) is a consequence of Corollary 4.24. We will use a descending induction starting with $q = n$.

A dimension count shows that

$$P_{2n}(X) = H_{2n}(X), \quad P_{2n-1}(X) = H_{2n-1}(X),$$

and (4.13) is trivially true for $q = n, n - 1$. The identity

$$\alpha \cap (\beta \cap c) = (\alpha \cup \beta) \cap c, \quad \forall \alpha, \beta \in H^\bullet(X), \quad c \in H_\bullet(X),$$

shows that for the induction step it suffices to prove that every element $c \in H_{n+q}(X)$ can be written uniquely as

$$c = c_0 + \omega \cap c_1, \quad c_1 \in H_{n+q+2}(X), \quad c_0 \in P_{n+q}(X).$$

According to Corollary 4.24 there exists a unique $z \in H_{n+q+2}(X)$ such that

$$\omega^{q+2} \cap z = \omega^{q+1} \cap c,$$

so that

$$c_0 := c - \omega \cap z \in P_{n+q}(X).$$

To prove the uniqueness of the decomposition assume

$$0 = c_0 + \omega \cap c_1, \quad c_0 \in P_{n+q}(X).$$

Then

$$0 = \omega^{q+1} \cap (c_0 + \omega \cap c_1) \implies \omega^{q+2} \cap c_1 = 0 \implies c_1 = 0 \implies c_0 = 0. \quad \square$$

The Lefschetz decomposition shows that the homology of X is completely determined by its primitive part. Moreover, the above proof shows that

$$0 \leq \dim P_{n+q} = b_{n+q} - b_{n+q+2} = b_{n-q} - b_{n-q-2},$$

which implies the *unimodality* of the Betti numbers of an algebraic manifold,

$$1 = b_0 \leq b_2 \leq \cdots \leq b_{2\lfloor n/2 \rfloor}, \quad b_1 \leq b_3 \leq \cdots \leq b_{2\lfloor (n-1)/2 \rfloor + 1},$$

where $\lfloor x \rfloor$ denotes the integer part of x . These inequalities introduce additional topological restrictions on algebraic manifolds. For example, the sphere S^4 cannot be an algebraic manifold because $b_2(S^4) = 0 < b_0(S^4) = 1$.

4.4 Vanishing Cycles and Local Monodromy

In this section we finally give the promised proof of Lemma 4.10.

Recall we are given a Morse function $\hat{f} : \hat{X} \rightarrow \mathbb{P}^1$ and its critical values t_1, \dots, t_r are all located in the upper closed hemisphere D_+ . We denote the corresponding critical points by p_1, \dots, p_r , so that

$$\hat{f}(p_j) = t_j, \quad \forall j.$$

We will identify D_+ with the unit closed disk at $0 \in \mathbb{C}$. Let $j = 1, \dots, r$.

- Denote by D_j a closed disk of very small radius ρ centered at $t_j \in D_+$. If $\rho \ll 1$ these disks are disjoint.
- Connect $*$ $\in \partial D_+$ to $t_j + \rho \in \partial D_j$ by a smooth path ℓ_j such that the resulting paths ℓ_1, \dots, ℓ_r are disjoint (see Figure 2.7). Set $\mathbf{k}_j := \ell_j \cup D_j$, $\ell = \bigcup \ell_j$ and $\mathbf{k} = \bigcup \mathbf{k}_j$.
- Denote by B_j a small closed ball of radius R in \hat{X} centered at p_j .

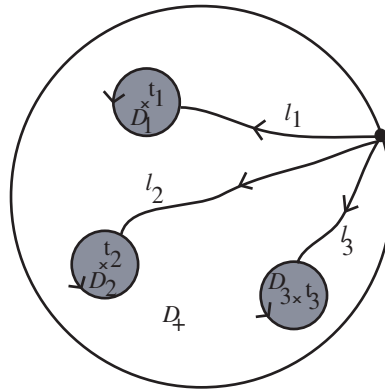

Fig. 4.2. Isolating the critical values.

The proof of Lemma 4.10 will be carried out in several steps.

Step 1. Localizing around the singular fibers. Set

$$L := f^{-1}(\ell), \quad K := \hat{f}^{-1}(\mathbf{k}).$$

We will show that \hat{X}_* is a deformation retract of L , and K is a deformation retract of \hat{X}_+ , so that the inclusions

$$(\hat{X}_+, \hat{X}_*) \hookrightarrow (\hat{X}_+, L) \hookrightarrow (K, L)$$

induce isomorphisms of all homology (and homotopy) groups.

Observe that \mathbf{k} is a strong deformation retract of D_+ and $*$ is a strong deformation retract of ℓ . Using the Ehresmann fibration theorem we deduce that we have fibrations

$$f : L \rightarrow \ell, \quad \hat{f} : \hat{X}_+ \setminus \hat{f}^{-1}\{t_1, \dots, t_r\} \rightarrow D_+ \setminus \{t_1, \dots, t_r\}.$$

Using the homotopy lifting property of fibrations (see [Ha, Section 4.3]) we obtain strong deformation retractions

$$L \rightarrow \hat{X}_*, \quad \hat{X}_+ \setminus \hat{f}^{-1}\{t_1, \dots, t_r\} \rightarrow K \setminus \hat{f}^{-1}\{t_1, \dots, t_r\}.$$

Fig. 4.3. *Isolating the critical points.*

Step 2. *Localizing near the critical points.* Set

$$\begin{aligned} \hat{X}_{D_j} &:= \hat{f}^{-1}(D_j), \quad \hat{X}_j := f^{-1}(t_j + \rho), \\ E_j &:= \hat{X}_{D_j} \cap B_j, \quad F_j := \hat{X}_j \cap B_j, \\ E &:= \cup_j E_j, \quad F := \cup_j F_j. \end{aligned}$$

The excision theorem shows that the inclusions $(\hat{X}_{D_j}, \hat{X}_j) \rightarrow (K, L)$ induce an isomorphism

$$\bigoplus_{j=1}^r H_{\bullet}(\hat{X}_{D_j}, \hat{X}_j) \rightarrow H_{\bullet}(K, L) \cong H_{\bullet}(\hat{X}_+, \hat{X}_*).$$

Now define

$$Y_j := \hat{X}_{D_j} \setminus \text{int}(B_j), \quad Z_j := F_j \setminus \text{int}(B_j).$$

The map \hat{f} induces a surjective submersion $\hat{f} : Y_j \rightarrow D_j$, and by the Ehresmann fibration theorem it defines a trivial fibration with fiber Z_j . In particular, Z_j is a deformation retract of Y_j , and thus $\hat{X}_j = F_j \cup Z_j$ is a deformation retract of $F_j \cup Y_j$. We deduce

$$H_\bullet(\hat{X}_{D_j}, \hat{X}_j) \cong H_\bullet(\hat{X}_{D_j}, F_j \cup Y_j) \cong H_\bullet(E_j, F_j),$$

where the last isomorphism is obtained by excising Y_j .

Step 3. Conclusion. We will show that for every $j = 1, \dots, r$ we have

$$H_q(E_j, F_j) = \begin{cases} 0 & \text{if } q \neq \dim_{\mathbb{C}} X = n \\ \mathbb{Z} & \text{if } q = n. \end{cases}$$

At this point we need to use the nondegeneracy of p_j . To simplify the presentation, in the sequel we will drop the subscript j .

By making B even smaller we can assume that there exist holomorphic coordinates (z_k) on B , and u near $\hat{f}(p)$, such that \hat{f} is described in these coordinates by $z_1^2 + \dots + z_n^2$. Then E and F can be given the explicit descriptions

$$\begin{aligned} E &= \left\{ \mathbf{z} = (z_1, \dots, z_n); \sum_i |z_i|^2 \leq r^2, \left| \sum_i z_i^2 \right| < \rho \right\}, \\ F &= F_\rho := \left\{ \mathbf{z} \in E; \sum_i z_i^2 = \rho \right\}. \end{aligned} \tag{4.15}$$

The region E can be contracted to the origin because $\mathbf{z} \in E \implies t\mathbf{z} \in E, \forall t \in [0, 1]$. This shows that the connecting homomorphism $H_q(E, F) \rightarrow H_{q-1}(F)$ is an isomorphism for $q \neq 0$. Moreover, $H_0(E, F) = 0$. Lemma 4.10 is now a consequence of the following result.

Lemma 4.27. F_ρ is diffeomorphic to the disk bundle of the tangent bundle TS^{n-1} .

Proof. Set

$$\begin{aligned} z_j &:= x_j + iy_j, \quad \mathbf{x} := (x_1, \dots, x_n), \quad \mathbf{y} := (y_1, \dots, y_n), \\ |\mathbf{x}|^2 &:= \sum_j x_j^2, \quad |\mathbf{y}|^2 := \sum_j y_j^2. \end{aligned}$$

The fiber F has the description

$$|\mathbf{x}|^2 = \rho + |\mathbf{y}|^2, \quad \mathbf{x} \cdot \mathbf{y} = 0 \in \mathbb{R}, \quad |\mathbf{x}|^2 + |\mathbf{y}|^2 \leq r^2.$$

In particular,

$$2|\mathbf{y}|^2 \leq r^2 - \rho.$$

Now let

$$\mathbf{u} := (\rho + |v|^2)^{-1/2} \mathbf{x} \in \mathbb{R}^n, \quad \mathbf{v} = \frac{2}{r^2 - \rho} \mathbf{y}.$$

In the coordinates \mathbf{u}, \mathbf{v} the fiber F has the description

$$|\mathbf{u}|^2 = 1, \quad \mathbf{u} \cdot \mathbf{v} = 0, \quad |\mathbf{v}|^2 \leq 1.$$

The first equality describes the unit sphere $S^{n-1} \subset \mathbb{R}^n$. Observe next that

$$\mathbf{u} \cdot \mathbf{v} \iff \mathbf{y} \perp \mathbf{u}$$

shows that \mathbf{v} is tangent to S^{n-1} at \mathbf{u} . It is now obvious that F is the disk bundle of TS^{n-1} . This completes the proof of Lemma 4.10. \square

We want to analyze in greater detail the picture emerging from the proof of Lemma 4.27. Denote by B a small closed ball centered at $0 \in \mathbb{C}^n$ and consider

$$f : B \rightarrow \mathbb{C}, \quad f(z) = z_1^2 + \cdots + z_n^2.$$

Let ρ be a positive and very small real number.

We have seen that the regular fiber $F_\rho = f^{-1}(\rho)$ ($0 < \rho \ll 1$) is diffeomorphic to a disk bundle over an $(n - 1)$ -sphere S_ρ of radius $\sqrt{\rho}$. This sphere is defined by the equation

$$S_\rho := \{\mathbf{Im} \mathbf{z} = 0\} \cap f^{-1}(\rho) \iff \{\mathbf{y} = 0, \quad |\mathbf{x}|^2 = \rho\}.$$

As $\rho \rightarrow 0$, i.e., we are looking at fibers closer and closer to the singular one $F_0 = f^{-1}(0)$, the radius of this sphere goes to zero, while for $\rho = 0$ the fiber is locally the cone $z_1^2 + \cdots + z_n^2 = 0$. We say that S_ρ is a *vanishing sphere*.

The homology class in F_ρ determined by an orientation on this vanishing sphere generates $H_{n-1}(F_\rho)$. Such a homology class was called *vanishing cycle* by Lefschetz. We will denote by Δ a homology class obtained in this fashion, i.e., from a vanishing sphere and an orientation on it (see Figure 4.4). The proof of Lemma 4.10 shows that Lefschetz's vanishing cycles coincide with what we previously named vanishing cycles.

Observe now that since $\partial : H_n(B, F) \rightarrow H_{n-1}(F)$ is an isomorphism, there exists a relative n -cycle $Z \in H_n(B, F)$ such that $\partial Z = \Delta$. The relative cycle Z is known as the *thimble* associated with the vanishing cycle Δ . It is filled in by the family (S_ρ) of shrinking spheres. In Figure 4.4 it is represented by the shaded disk.

Denote by $D_\rho \subset \mathbb{C}$ the closed disk of radius ρ centered at the origin and by $B_r \subset \mathbb{C}^n$ the closed ball of radius r centered at the origin. Set

$$E_{r,\rho} := \{\mathbf{z} \in B_r; \quad f(z) \in D_\rho\}, \quad E_{r,\rho}^* := \{\mathbf{z} \in B_r; \quad 0 < |f(z)| < \rho\},$$

$$\partial E_{r,\rho} := \{\mathbf{z} \in \partial B_r; \quad f(z) \in D_\rho\}.$$

We will use the following technical result, whose proof is left to the reader.

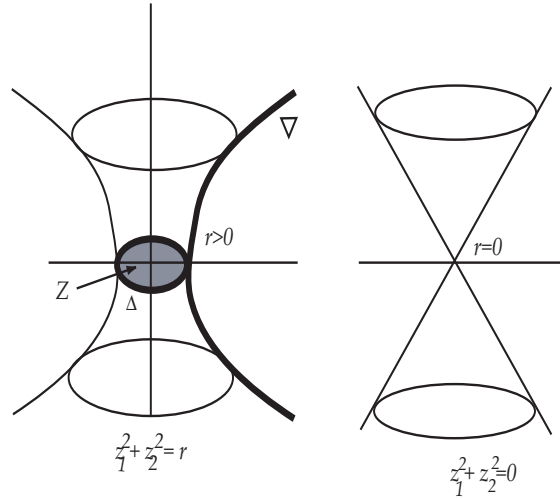

Fig. 4.4. The vanishing cycle for functions of $n = 2$ variables.

Lemma 4.28. For any $\rho, r > 0$ such that $r^2 > \rho$ the maps

$$f : E_{r,\rho}^* \rightarrow D_\rho \setminus \{0\} =: D_\rho^*, \quad f_\partial : \partial E_{r,\rho} \rightarrow D_\rho$$

are proper surjective submersions. □

By rescaling we can assume $1 < \rho < 2 = r$. Set $B = B_r, D = D_\rho$, etc. According to the Ehresmann fibration theorem we have two locally trivial fibrations.

- $F \hookrightarrow E^* \twoheadrightarrow D^*$ with standard fiber the manifold with boundary

$$F \cong f^{-1}(*) \cap \bar{B}.$$

- $\partial F \hookrightarrow \partial E \twoheadrightarrow D$ with standard fiber $\partial F \cong f^{-1}(*) \cap \partial \bar{B}$. The bundle $\partial E \rightarrow D$ is a globally trivializable bundle because its base is contractible.

Choose the basepoint $* = 1$. From the proof of Lemma 4.27 we have

$$F = f^{-1}(*) = \{ \mathbf{z} = \mathbf{x} + i\mathbf{y} \in \mathbb{C}^n; \quad |\mathbf{x}|^2 + |\mathbf{y}|^2 \leq 4, \quad |\mathbf{x}|^2 = 1 + |\mathbf{y}|^2, \quad \mathbf{x} \cdot \mathbf{y} = 0 \}.$$

Denote by \mathbb{M} the standard model for the fiber, incarnated as the unit disk bundle determined by the tangent bundle of the unit sphere $S^{n-1} \hookrightarrow \mathbb{R}^n$. The standard model \mathbb{M} has the algebraic description

$$\mathbb{M} = \left\{ (\mathbf{u}, \mathbf{v}) \in \mathbb{R}^n \times \mathbb{R}^n; \quad |\mathbf{u}| = 1, \quad \mathbf{u} \cdot \mathbf{v} = 0, \quad |\mathbf{v}| \leq 1 \right\}.$$

Note that

$$\partial\mathbb{M} = \left\{ (\mathbf{u}, \mathbf{v}) \in \mathbb{R}^n \times \mathbb{R}^n; \quad |\mathbf{u}| = 1 = |\mathbf{v}|, \quad \mathbf{u} \cdot \mathbf{v} = 0 \right\}.$$

We have a diffeomorphism

$$\begin{aligned} \Phi : F \rightarrow \mathbb{M}, \quad F \ni \mathbf{z} = \mathbf{x} + i\mathbf{y}, \mapsto \begin{cases} \mathbf{u} = (1 + |\mathbf{y}|^2)^{-1/2} \cdot \mathbf{x} \\ \mathbf{v} = \alpha\mathbf{y}, \end{cases} & (\Phi) \\ \alpha = \sqrt{2/3}. \end{aligned}$$

Its inverse is given by

$$\mathbb{M} \ni (\mathbf{u}, \mathbf{v}) \xrightarrow{\Phi^{-1}} \begin{cases} \mathbf{x} = (1 + |\mathbf{v}|^2/\alpha^2)^{1/2}\mathbf{u}, \\ \mathbf{y} = \alpha^{-1}\mathbf{v}. \end{cases} \quad (\Phi^{-1})$$

This diffeomorphism Φ maps the vanishing sphere $\Sigma = \{\mathbf{Im} \mathbf{z} = 0\} \subset F$ to the sphere

$$\mathbb{S} := \left\{ (\mathbf{u}, \mathbf{v}) \in \mathbb{R}^n \times \mathbb{R}^n; \quad |\mathbf{u}| = 1, \quad \mathbf{v} = 0 \right\}.$$

We will say that \mathbb{S} is the *standard model* for the vanishing cycle. The *standard model* for the thimble is the ball $\{|\mathbf{u}| \leq 1\}$ bounding \mathbb{S} .

Fix a trivialization $\partial E \xrightarrow{\cong} \partial F \times D$ and a metric h on ∂F . We now equip ∂E with the product metric $g_\partial := h \oplus h_0$, where h_0 denotes the Euclidean metric on D . Now extend g_∂ to a metric on E and denote by H the subbundle of TE^* consisting of tangent vectors g -orthogonal to the fibers of f . The differential f_* produces isomorphisms

$$f_* : H_p \rightarrow T_{f(p)}D^*, \quad \forall p \in E^*.$$

Suppose $\gamma : [0, 1] \rightarrow D^*$ is a smooth path beginning and ending at $*$, $\gamma(0) = \gamma(1) = *$. We obtain for each $p \in F = f^{-1}(*)$ a smooth path $\tilde{\gamma}_p : [0, 1] \rightarrow E$ that is tangent to the horizontal sub-bundle H , and it is a lift of w starting at p , i.e., the diagram below is commutative:

$$\begin{array}{ccc} & (E^*, p) & \\ & \nearrow \tilde{\gamma}_p & \downarrow f \\ ([0, 1], 0) & \xrightarrow{\gamma} & (D^*, *) \end{array}$$

We get in this fashion a map $h_\gamma : F = f^{-1}(*) \rightarrow f^{-1}(*)$, $p \mapsto \tilde{\gamma}_p(*)$.

The standard results on the smooth dependence of solutions of ODEs on initial data show that h_γ is a smooth map. It is in fact a diffeomorphism of F with the property that

$$h_\gamma |_{\partial F} = \mathbb{1}_{\partial F}.$$

The map h_γ is not canonical, because it depends on several choices: the choice of trivialization $\partial E \cong \partial F \times D$, the choice of metric h on F , and the choice of the extension g of g_∂ .

We say that two diffeomorphisms $G_0, G_1 : F \rightarrow F$ such that $G_i|_{\partial F} = \mathbb{1}_{\partial F}$ are *isotopic* if there exists a smooth homotopy

$$G : [0, 1] \times F \rightarrow F$$

connecting them such that for each t the map $G_t = G(t, \bullet) : F \rightarrow F$ is a diffeomorphism satisfying $G_t|_{\partial F} = \mathbb{1}_{\partial F}$ for all $t \in [0, 1]$.

The isotopy class of $h_\gamma : F \rightarrow F$ is independent of the various choices listed above, and in fact depends only on the image of γ in $\pi_1(D^*, *)$. The induced map

$$[h_\gamma] : H_\bullet(F) \rightarrow H_\bullet(F)$$

is called the *(homological) monodromy along the loop γ* . The correspondence

$$[h] : \pi_1(D^*, *) \ni \gamma \longmapsto h_\gamma \in \text{Aut}(H_\bullet(F))$$

is a group morphism called *the local (homological) monodromy*.

Since $h_\gamma|_{\partial F} = \mathbb{1}_{\partial F}$, we obtain another morphism

$$[h]^{rel} : \pi_1(D^*, *) \rightarrow \text{Aut}(H_\bullet(F, \partial F)),$$

which we will call *local relative monodromy*.

Observe that if z is a singular n -chain in F such that $\partial z \in \partial F$ (hence z defines an element $[z] \in H_n(F, \partial F)$), then for every $\gamma \in \pi_1(D^*, *)$ we have

$$\partial z = \partial h_\gamma z \implies \partial(z - h_\gamma z) = 0,$$

so that the singular chain $(z - h_\gamma z)$ is a cycle in F . In this fashion we obtain a *linear* map

$$\mathbf{var} : \pi_1(D^*, *) \rightarrow \text{Hom}(H_{n-1}(F, \partial F) \rightarrow H_{n-1}(F)),$$

$$\mathbf{var}_\gamma(z) = [h_\gamma]^{rel} z - z, \quad z \in H_{n-1}(F, \partial F), \quad \gamma \in \pi_1(D^*, *),$$

called the *variation map*.

The local Picard–Lefschetz formula will provide an explicit description of this variation map. To formulate it we need to make a topological digression.

An orientation $\mathbf{or} = \mathbf{or}_F$ on F defines a *nondegenerate* intersection pairing

$$*\mathbf{or} : H_{n-1}(F, \partial F) \times H_{n-1}(F) \rightarrow \mathbb{Z}$$

formally defined by the equality

$$c_1 *\mathbf{or} c_2 = \langle PD_{\mathbf{or}}^{-1}(i_*(c_1)), c_2 \rangle,$$

where $i_* : H_{n-1}(F) \rightarrow H_{n-1}(F, \partial F)$ is the inclusion induced morphism,

$$PD_{\mathbf{or}} : H^{n-1}(F) \rightarrow H_{n-1}(F, \partial F), \quad u \mapsto u \cap [F, \partial F],$$

is the Poincaré–Lefschetz duality defined by the orientation \mathbf{or} , and $\langle -, - \rangle$ is the Kronecker pairing.

The group $H_{n-1}(F, \partial F)$ is an infinite cyclic group. Since F is the unit disk bundle in the tangent bundle $T\Sigma$, a generator of $H_{n-1}(F, \partial F)$ can be represented by a disk ∇ in this disk bundle (see Figure 4.5). The generator is fixed by a choice of orientation on ∇ . Thus \mathbf{var}_γ is completely understood once we understand its action on ∇ (see Figure 4.5).

The group $H_{n-1}(F)$ is also an infinite cyclic group. It has two generators. Each of them is represented by an embedded $(n - 1)$ -sphere Σ equipped with one of the two possible orientations. We can thus write

$$\mathbf{var}_\gamma([\nabla]) = \nu_\gamma(\nabla)[\Sigma], \quad \nu(\nabla) = \nu_\gamma([\nabla, \mathbf{or}_\nabla]) \in \mathbb{Z}.$$

The integer $\nu_\gamma([\nabla])$ is completely determined by the *Picard–Lefschetz number*,

$$m_\gamma(\mathbf{or}_F) := [\nabla] *_{\mathbf{or}_F} \mathbf{var}_\gamma([\nabla]) = \nu_\gamma([\nabla])[\nabla] * [\Sigma].$$

Hence

$$\mathbf{var}_\gamma([\nabla]) = m_\gamma(\mathbf{or}_F)(\nabla *_{\mathbf{or}_F} [\Sigma]) [\Sigma] = \underbrace{([\nabla] * [\Sigma])(\nabla * \mathbf{var}_\gamma(\nabla))}_{\nu_\gamma([\nabla])} [\Sigma],$$

$$\mathbf{var}_\gamma(z) = m_\gamma(\mathbf{or}_F)(z *_{\mathbf{or}_F} [\Sigma]) [\Sigma].$$

The integer m_γ depends on choices of orientations on \mathbf{or}_F , \mathbf{or}_∇ , and \mathbf{or}_Σ on F , ∇ and Σ , but ν_γ depends only on the the orientations on ∇ and Σ . Let us explain how to fix such orientations.

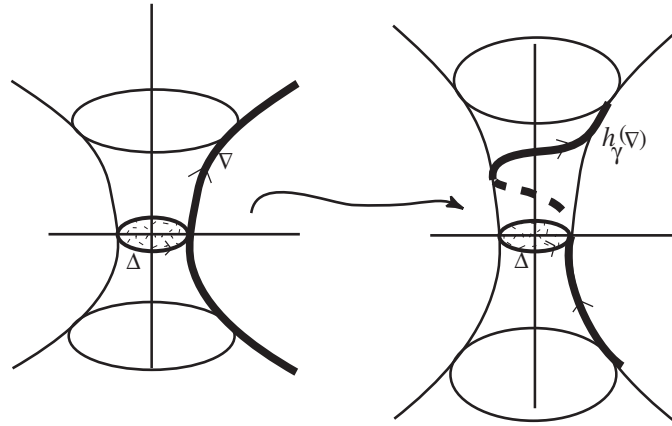

Fig. 4.5. The effect of monodromy on ∇ .

The diffeomorphism Φ maps the vanishing sphere $\Sigma \subset F$ to the sphere \mathbb{S} described in the (\mathbf{u}, \mathbf{v}) coordinates by $\mathbf{v} = 0, |\mathbf{u}| = 1$. This is oriented as the boundary of the unit disk $\{|\mathbf{u}| \leq 1\}$ via the outer-normal-first convention.⁴ We denote by $\Delta \in H_{n-1}(F)$ the cycle determined by \mathbb{S} with this orientation.

Let

$$\mathbf{u}_\pm = (\pm 1, 0, \dots, 0), \quad P_\pm = (\mathbf{u}_\pm, \mathbf{0}) \in \mathbb{S} \subset \mathbb{M}. \quad (4.16)$$

The standard model \mathbb{M} admits a natural orientation as the total space of a fibration, where we use the fiber-first convention

$$\mathbf{or}(\text{total space}) = \mathbf{or}(\text{fiber}) \wedge \mathbf{or}(\text{base}).$$

Observe that since \mathbb{M} is (essentially) the tangent bundle of \mathbb{S} , an orientation on \mathbb{S} determines tautologically an orientation in each fiber of \mathbb{M} . Thus the orientation on \mathbb{S} as boundary of an Euclidean ball determines via the above formula an orientation on \mathbb{M} . We will refer to this orientation as the *bundle orientation*.⁵

Near $P_+ \in \mathbb{M}$ we can use as local coordinates the pair

$$(\boldsymbol{\xi}, \boldsymbol{\eta}), \quad \boldsymbol{\xi} = (u_2, \dots, u_n), \quad \boldsymbol{\eta} = (v_2, \dots, v_n). \quad (4.17)$$

The orientation of \mathbb{S} at P_+ is given by

$$d\boldsymbol{\xi} := du_2 \wedge \dots \wedge du_n,$$

so that the orientation of Σ at $\Phi^{-1}(P_+)$ is given by $dx_2 \wedge \dots \wedge dx_n$. The bundle orientation of \mathbb{M} is described in these coordinates near P_+ by the form

$$\begin{aligned} \mathbf{or}_{\text{bundle}} &\sim d\boldsymbol{\eta} \wedge d\boldsymbol{\xi} = dv_2 \wedge \dots \wedge dv_n \wedge du_2 \wedge \dots \wedge du_n \\ &\xleftarrow{\Phi} dy_2 \wedge \dots \wedge dy_n \wedge dx_2 \wedge \dots \wedge dx_n. \end{aligned}$$

Using the identification (Φ) between F and \mathbb{M} we deduce that we can represent ∇ as the fiber \mathbb{T}_+ of $\mathbb{M} \rightarrow \mathbb{S}$ over the north pole P_+ (defined in (4.16)) equipped with some orientation. We choose this orientation by regarding \mathbb{T}_+ as the tangent space to \mathbb{S} at P_+ . More concretely, the orientation on \mathbb{T}_+ is given by

$$\mathbf{or}_{\mathbb{T}_+} \sim dv_2 \wedge \dots \wedge dv_n \xleftarrow{\Phi} dy_2 \wedge \dots \wedge dy_n.$$

We denote by $\nabla \in H_{n-1}(F, \partial F)$ the cycle determined by \mathbb{T}_+ with the above orientation.

⁴ The orientation of the disk is determined by a linear ordering of the variables u_1, \dots, u_n .

⁵ Note that while in the definition of the bundle orientation we tacitly used a linear ordering of the variables u_i , the bundle orientation itself is independent of such a choice.

On the other hand, F has a natural orientation as a complex manifold. We will refer to it as the *complex orientation*. The collection (z_2, \dots, z_n) defines holomorphic local coordinates on F near $\Phi^{-1}(P_+)$, so that

$$\mathbf{or}_{\text{complex}} = dx_2 \wedge dy_2 \wedge \cdots \wedge dx_n \wedge dy_n.$$

We see that⁶

$$\mathbf{or}_{\text{complex}} = (-1)^{n(n-1)/2} \mathbf{or}_{\text{bundle}}.$$

We denote by \circ (respectively $*$) the intersection number in $H_{n-1}(F)$ with respect to the bundle (respectively complex) orientation. Then⁷

$$1 = \nabla \circ \Delta = (-1)^{n(n-1)/2} \nabla * \Delta$$

and

$$\begin{aligned} \Delta \circ \Delta &= (-1)^{n(n-1)/2} \Delta * \Delta = \mathbf{e}(TS^{n-1})[S^{n-1}] \\ &= \chi(S^{n-1}) = \begin{cases} 0 & \text{if } n \text{ is even,} \\ 2 & \text{if } n \text{ is odd.} \end{cases} \end{aligned} \tag{4.18}$$

Above, \mathbf{e} denotes the Euler class of TS^{n-1} .

The loop $\gamma_1 : [0, 1] \ni t \mapsto \gamma_1(t) = e^{2\pi it} \in \mathbb{D}^*$ generates the fundamental group of D^* , and thus the variation map is completely understood once we understand the morphism of \mathbb{Z} -modules

$$\mathbf{var}_1 := \mathbf{var}_{\gamma_1} : H_{n-1}(F, \partial F) \rightarrow H_{n-1}(F).$$

Once an orientation \mathbf{or}_F on F is chosen, we have a Poincaré duality isomorphism

$$H_{n-1}(F) \cong \text{Hom}_{\mathbb{Z}}(H_{n-1}(F, \partial F), \mathbb{Z}),$$

and the morphism \mathbf{var}_1 is completely determined by the *Picard–Lefschetz number*

$$m_1(\mathbf{or}_F) := \nabla *_{\mathbf{or}_F} \mathbf{var}_1(\nabla).$$

We have the following fundamental result.

Theorem 4.29 (Local Picard–Lefschetz formula).

$$\begin{aligned} m_1(\mathbf{or}_{\text{bundle}}) &= \nabla \circ \mathbf{var}_1(\nabla) = (-1)^n, \\ m_1(\mathbf{or}_{\text{complex}}) &= \nabla * \mathbf{var}_1(\nabla) = (-1)^{n(n+1)/2}, \\ \mathbf{var}_1(\nabla) &= (-1)^n \Delta, \end{aligned}$$

and

$$\mathbf{var}_1(z) = (-1)^n (z \circ \Sigma) \Sigma = (-1)^{n(n+1)/2} (z * \Sigma) \Sigma, \quad \forall z \in H_{n-1}(F, \partial F).$$

⁶ This sign is different from the one in [AGV2] due to our use of the fiber-first convention. This affects the appearance of the Picard-Lefschetz formulæ. The fiber-first convention is employed in [Lam] as well.

⁷ The choices of Δ and ∇ depended on linear orderings of the variables u_i . However, the intersection number $\nabla \circ \Delta$ is *independent* of such choices.

4.5 Proof of the Picard–Lefschetz formula

The following proof of the local Picard–Lefschetz formula is inspired from [HZ] and consists of a three-step reduction process.

We start by constructing an explicit trivialization of the fibration $\partial E \rightarrow D$. Set

$$E_w := f^{-1}(w) \cap \bar{B}, \quad 0 \leq |w| < \rho, \quad F = E_{w=1}.$$

Note that

$$\partial E_{a+ib} = \left\{ \mathbf{x} + i\mathbf{y}; \quad |\mathbf{x}|^2 = a + |\mathbf{y}|^2, \quad 2\mathbf{x} \cdot \mathbf{y} = b, \quad |\mathbf{x}|^2 + |\mathbf{y}|^2 = 4 \right\}.$$

For every $w = a + ib \in D$ define $\Gamma_w : \partial E_w \rightarrow \partial \mathbb{M}$,

$$\partial F_w \ni \mathbf{x} + i\mathbf{y} \mapsto \begin{cases} \mathbf{u} = c_1(w)\mathbf{x}, \\ \mathbf{v} = c_3(w)(\mathbf{y} + c_2(w)\mathbf{x}), \end{cases} \quad (4.19)$$

$$|\mathbf{u}| = 1, \quad |\mathbf{v}| \leq 1,$$

where

$$c_1(w) = \left(\frac{2}{4+a} \right)^{1/2}, \quad c_2(w) = -\frac{b}{4+a}, \quad (4.20)$$

$$c_3(w) = \left(\frac{8+2a}{16-a^2-b^2} \right)^{1/2}.$$

Observe that Γ_1 coincides with the identification (Φ) between F and \mathbb{M} . The family $(\Gamma_w)_{|w|<\rho}$ defines a trivialization $\Gamma : \partial E \rightarrow \partial \mathbb{M} \times D$, $\mathbf{z} \mapsto (\Gamma_{f(\mathbf{z})}(\mathbf{z}), f(\mathbf{z}))$. We set

$$E_{|w|=1} := f^{-1}(\{|w|=1\}) \cap \bar{B} = E|_{\{|w|=1\}}.$$

The manifold $E_{|w|=1}$ is a smooth compact manifold with boundary

$$\partial E_{|w|=1} = f^{-1}(\{|w|=1\}) \cap \partial \bar{B}.$$

The boundary $\partial E_{|w|=1}$ fibers over $\{|w|=1\}$ and is the restriction to the unit circle $\{|w|=1\}$ of the trivial fibration $\partial E \rightarrow D$. The above trivialization Γ of $\partial E \rightarrow D$ induces a trivialization of $\partial E_{|w|=1} \rightarrow \{|w|=1\}$.

Fix a vector field V on $E_{|w|=1}$ such that

$$f_*(V) = 2\pi\partial_\theta \quad \text{and} \quad \Gamma_*(V|_{\partial E_{|w|=1}}) = 2\pi\partial_\theta \quad \text{on} \quad \partial \mathbb{M} \times \{|w|=1\}.$$

Denote by μ_t the time t -map of the flow determined by V . Observe that μ_t defines a diffeomorphism

$$\mu_t : F \rightarrow F_{e^{2\pi it}}$$

compatible with the chosen trivialization Γ_w of ∂E . More precisely, this means that the diagram below is commutative:

$$\begin{array}{ccc} \partial F & \xrightarrow{\Gamma_1(-\Phi)} & \partial \mathbb{M} \\ \mu_t \downarrow & & \downarrow \mathbf{1}_{\partial \mathbb{M}} \\ \partial F_{e^{2\pi i t}} & \xrightarrow{\Gamma_{e^{2\pi i t}}} & \partial \mathbb{M} \end{array}$$

Consider also the flow Ω_t on $E_{|w|=1}$ given by

$$\Omega_t(\mathbf{z}) = \exp(\pi i t)\mathbf{z} = (\cos(\pi t)\mathbf{x} - \sin(\pi t)\mathbf{y}) + i(\sin(\pi t)\mathbf{x} + \cos(\pi t)\mathbf{y}). \quad (4.21)$$

This flow is periodic, and since $f(\Omega_t \mathbf{z}) = e^{2\pi i t} f(\mathbf{z})$, it satisfies

$$\Omega_t(F) = F_{e^{2\pi i t}}.$$

However, Ω_t is *not compatible* with the chosen trivialization of ∂E , because $\Omega_1|_{\partial F_1}$ is the antipodal map $\mathbf{z} \mapsto -\mathbf{z}$.

We pick two geometric representatives $T_{\pm} \subset F$ of ∇ . More precisely, we define T_+ so that $\mathbb{T}_+ = \Phi(T_+) \subset \mathbb{M}$ is the fiber of $\mathbb{M} \rightarrow \mathbb{S}$ over the north pole $P_+ \in \mathbb{S}$. As we have seen in the previous section, \mathbb{T}_+ is oriented by

$$dv_2 \wedge \cdots \wedge dv_n \iff dy_2 \wedge \cdots \wedge dy_n.$$

Define $\mathbb{T}_- \subset \mathbb{M}$ as the fiber of $\mathbb{M} \rightarrow \mathbb{S}$ over the south pole $P_- \in \mathbb{S}$ and set $T_- = \Phi^{-1}(\mathbb{T}_-)$.

The orientation of \mathbb{S} at P_- is determined by the outer-normal-first convention, and we deduce that it is given by $-du_2 \wedge \cdots \wedge du_n$. We deduce that \mathbb{T}_- is oriented by $-dv_2 \wedge \cdots \wedge dv_n$. Inside F the chain T_- is described by

$$\mathbf{x} = (1 + |\mathbf{y}|^2/\alpha^2)^{1/2} \mathbf{u}_- \iff x_1 < 0, \quad x_2 = \cdots = x_n = 0,$$

and it is oriented by $-dy_2 \wedge \cdots \wedge dy_n$.

Note that $\Omega_1 = -1$, so that taking into account the orientations, we have

$$\Omega_1(T_+) = (-1)^n T_- = (-1)^n \nabla. \quad (4.22)$$

For any smooth oriented submanifolds A, B of \mathbb{M} with disjoint boundaries $\partial A \cap \partial B = \emptyset$, of complementary dimensions, and intersecting transversally, we denote by $A \circ B$ their intersection number computed using the *bundle orientation* on F . Set

$$m := m_1(\mathbf{or}_{bundle}) = \nabla \circ \mathbf{var}(\nabla).$$

Step 1.

$$m = (-1)^n \Omega_1(T_+) \circ \mu_1(T_+).$$

Note that

$$m = \nabla \circ (\mu_1(T_+) - T_+) = T_- \circ (\mu_1(T_+) - T_+).$$

Observe that the manifolds T_+ and T_- in F are disjoint so that

$$m = T_- \circ \mu_1(T_+) \stackrel{(4.22)}{=} (-1)^n \Omega_1(T_+) \circ \mu_1(T_+).$$

Step 2.

$$\Omega_1(T_+) \circ \mu_1(T_+) = \Omega_t(T_+) \circ \mu_t(T_+), \quad \forall t \in (0, 1].$$

To see this, observe that the manifolds $\Omega_t(T_+)$ and $\mu_t(T_+)$ have disjoint boundaries if $0 < t \leq 1$. Indeed, the compatibility of μ_t with the boundary trivialization Γ implies

$$\Gamma_{e^{2\pi it}} \mu_t(\partial T_+) = \Gamma_{e^{2\pi it}} \mu_t \Phi^{-1}(\partial \mathbb{T}_+) = \partial \mathbb{T}_+ = \{(\mathbf{u}_+, \mathbf{v}) \in \mathbb{M}; \mathbf{v} = 1\}.$$

On the other hand,

$$\begin{aligned} \Gamma_{e^{2\pi it}} \Omega_t(\partial T_+) &= \Gamma_{e^{2\pi it}} \Omega_t \Phi^{-1}(\partial \mathbb{T}_+) \\ &= \Gamma_{e^{2\pi it}} \Omega_t \left(\sqrt{\frac{1 + \alpha^2}{\alpha^2}} \cdot \mathbf{u}_+, \alpha^{-1} \mathbf{v} \right) \quad (\alpha^2 = 2/3), \end{aligned}$$

and from the explicit descriptions (4.19) for $\Gamma_{e^{2\pi it}}$ and (4.21) for Ω_t we deduce

$$\emptyset = \Gamma_{e^{2\pi it}} \Omega_t(\partial T_+) \cap \partial \mathbb{T}_+ = \Gamma_{e^{2\pi it}} \Omega_t(\partial T_+) \cap \Gamma_{e^{2\pi it}} \mu_t(\partial T_+).$$

Hence the deformations

$$\Omega_1(T_+) \rightarrow \Omega_{1-s(1-t)}(T_+), \quad \mu_1(T_+) \rightarrow \mu_{1-s(1-t)}(T_+)$$

do not change the intersection numbers.

Step 3.

$$\Omega_t(T_+) \circ \mu_t(T_+) = 1 \quad \text{if } t > 0 \text{ is sufficiently small.}$$

Set

$$A_t := \Omega_t(T_+), \quad B_t = \mu_t(T_+).$$

For $0 < \varepsilon \ll 1$ denote by C_ε the arc $C_\varepsilon = \{\exp(2\pi it); 0 \leq t \leq \varepsilon\}$. Extend the trivialization $\Gamma : \partial E|_{C_\varepsilon} \rightarrow \partial \mathbb{M} \times C_\varepsilon$ to a trivialization

$$\tilde{\Gamma} : E|_{C_\varepsilon} \rightarrow \mathbb{M} \times C_\varepsilon$$

such that $\tilde{\Gamma}|_F = \Phi$.

For $t \in [0, \varepsilon]$ we can view Ω_t and μ_t as diffeomorphisms $\omega_t, h_t : \mathbb{M} \rightarrow \mathbb{M}$ such that the diagrams below are commutative:

$$\begin{array}{ccc} F & \xrightarrow{\tilde{\Gamma}_1} & \mathbb{M} \\ \Omega_t \downarrow & & \downarrow \omega_t \\ F_{w(t)} & \xrightarrow{\tilde{\Gamma}_{w(t)}} & \mathbb{M} \end{array}$$

$$\begin{array}{ccc} F & \xrightarrow{\tilde{\Gamma}} & \mathbb{M} \\ \mu_t \downarrow & & \downarrow h_t \\ F_{e^{2\pi it}} & \xrightarrow{\tilde{\Gamma}_e} & \mathbb{M} \end{array}$$

Set $\mathbb{A}_t = \tilde{\Gamma}_{e^{2\pi it}}(A_t) = \omega_t(\mathbb{T}_+)$ and $\mathbb{B}_t = \tilde{\Gamma}_{e^{2\pi it}}(B_t) = h_t(\mathbb{T}_+)$. Clearly

$$A_t \circ B_t = \mathbb{A}_t \circ \mathbb{B}_t.$$

Observe that $h_t|_{\partial\mathbb{M}} = \mathbb{1}_{\mathbb{M}}$, so that $\mathbb{B}_t(\mathbb{T}_+)$ is homotopic to \mathbb{T}_+ via homotopies that are trivial along the boundary. Such homotopies do not alter the intersection number, and we have

$$\mathbb{A}_t \circ \mathbb{B}_t = \mathbb{A}_t \circ \mathbb{T}_+.$$

Along $\partial\mathbb{M}$ we have

$$\omega_t|_{\partial M} = \Psi_t := \Gamma_{e^{2\pi it}} \circ \Omega_t \circ \Gamma_1^{-1}. \quad (4.23)$$

Choose $0 < \hbar < \frac{1}{2}$. For t sufficiently small the manifold \mathbb{A}_t lies in the tubular neighborhood

$$U_{\hbar} := \left\{ (\boldsymbol{\xi}, \boldsymbol{\eta}); |\boldsymbol{\xi}| < r, |\boldsymbol{\eta}| \leq 1 \right\}$$

of fiber $\mathbb{T}_+ \subset \mathbb{M}$, where as in (4.17) we set $\boldsymbol{\xi} = (u_2, \dots, u_n)$ and $\boldsymbol{\eta} = (v_2, \dots, v_n)$. More precisely, if $P = (\mathbf{u}, \mathbf{v})$ is a point of \mathbb{M} near P_+ then its $(\boldsymbol{\xi}, \boldsymbol{\eta})$ -coordinates are $\mathbf{pr}(\mathbf{u}, \mathbf{v})$, where \mathbf{pr} denotes the orthogonal projection

$$\mathbf{pr} : \mathbb{R}^n \times \mathbb{R}^n \rightarrow \mathbb{R}^{n-1} \times \mathbb{R}^{n-1}, \quad (\mathbf{u}, \mathbf{v}) \mapsto (u_2, \dots, u_n; v_2, \dots, v_n).$$

We can now rewrite (4.23) entirely in terms of the local coordinates $(\boldsymbol{\xi}, \boldsymbol{\eta})$ as

$$\omega_t(\boldsymbol{\xi}, \boldsymbol{\eta}) = \mathbf{pr} \circ \Psi_t = \mathbf{pr} \circ \Gamma_{w(t)} \circ \Omega_t \circ \Gamma_1^{-1} \left(u(\boldsymbol{\xi}, \boldsymbol{\eta}), \mathbf{v}(\boldsymbol{\xi}, \boldsymbol{\eta}) \right).$$

The coordinates $(\boldsymbol{\xi}, \boldsymbol{\eta})$ have a very attractive feature. Namely, in these coordinates, along $\partial\mathbb{M}$, the diffeomorphism Ψ_t is the restriction to $\partial\mathbb{M}$ of a (real) linear operator

$$L_t : \mathbb{R}^{n-1} \times \mathbb{R}^{n-1} \rightarrow \mathbb{R}^{n-1} \times \mathbb{R}^{n-1}.$$

More precisely,

$$L_t \begin{bmatrix} \boldsymbol{\xi} \\ \boldsymbol{\eta} \end{bmatrix} = C(t)R(t)C(0)^{-1} \cdot \begin{bmatrix} \boldsymbol{\xi} \\ \boldsymbol{\eta} \end{bmatrix},$$

where

$$C(t) := \begin{bmatrix} \mathbf{c}_1(t) & 0 \\ \mathbf{c}_2(t)\mathbf{c}_3(t) & \mathbf{c}_3(t) \end{bmatrix}, \quad R(t) := \begin{bmatrix} \cos(\pi t) & -\sin(\pi t) \\ \sin(\pi t) & \cos(\pi t) \end{bmatrix},$$

and $\mathbf{c}_k(t) := c_k(e^{2\pi it})$, $k = 1, 2, 3$. The exact description of $c_k(w)$ is given in (4.20). We can thus replace $\mathbb{A}_t = \omega_t(\mathbb{T}_+)$ with $L_t(\mathbb{T}_+)$ for all t sufficiently small without affecting the intersection number because L_t is very close to ω_t for t small and $\partial\mathbb{A}_t = \partial L_t(\mathbb{T}_+)$.

For t sufficiently small we have

$$L_t = L_0 + t\dot{L}_0 + O(t^2), \quad L_0 = \mathbb{1}, \quad \dot{L}_0 := \left. \frac{d}{dt} \right|_{t=0} L_t,$$

where

$$\dot{L}_0 = \dot{C}(0)C(0)^{-1} + C(0)JC(0)^{-1}, \quad J = \dot{R}(0) = \pi \begin{bmatrix} 0 & -1 \\ 1 & 0 \end{bmatrix}.$$

Using (4.20) with $a = \cos(2\pi t)$, $b = \sin(2\pi t)$ we deduce

$$\begin{aligned} \mathbf{c}_1(0) &= \sqrt{\frac{2}{5}} > 0, \quad \mathbf{c}_2(0) = 0, \quad \mathbf{c}_3(0) = \sqrt{\frac{2}{3}} > 0, \\ \dot{\mathbf{c}}_1(0) &= \dot{\mathbf{c}}_3(0) = 0, \quad \dot{\mathbf{c}}_2(0) = -\frac{2\pi}{25}. \end{aligned}$$

Thus

$$\begin{aligned} \dot{C}(0) &= -\frac{2\pi}{25} \begin{bmatrix} 0 & 0 \\ \mathbf{c}_3(0) & 0 \end{bmatrix}, \quad C(0)^{-1} = \begin{bmatrix} \frac{1}{\mathbf{c}_1(0)} & 0 \\ 0 & \frac{1}{\mathbf{c}_3(0)} \end{bmatrix} \\ \dot{C}(0)C(0)^{-1} &= -\frac{2\pi}{25} \begin{bmatrix} 0 & 0 \\ \frac{\mathbf{c}_3(0)}{\mathbf{c}_1(0)} & 0 \end{bmatrix}. \end{aligned}$$

Next

$$\begin{aligned} C(0)JC(0)^{-1} &= \pi \begin{bmatrix} \mathbf{c}_1(0) & 0 \\ 0 & \mathbf{c}_3(0) \end{bmatrix} \begin{bmatrix} 0 & -1 \\ 1 & 0 \end{bmatrix} \begin{bmatrix} \frac{1}{\mathbf{c}_1(0)} & 0 \\ 0 & \frac{1}{\mathbf{c}_3(0)} \end{bmatrix} \\ &= \pi \begin{bmatrix} \mathbf{c}_1(0) & 0 \\ 0 & \mathbf{c}_3(0) \end{bmatrix} \begin{bmatrix} 0 & -\frac{1}{\mathbf{c}_3(0)} \\ \frac{1}{\mathbf{c}_1(0)} & 0 \end{bmatrix} = \pi \begin{bmatrix} 0 & -\frac{\mathbf{c}_1(0)}{\mathbf{c}_3(0)} \\ \frac{\mathbf{c}_3(0)}{\mathbf{c}_1(0)} & 0 \end{bmatrix}. \end{aligned}$$

The upshot is that the matrix \dot{L}_0 has the form

$$\dot{L}_0 = \begin{bmatrix} 0 & -a \\ b & 0 \end{bmatrix}, \quad a, b > 0.$$

For t sufficiently small we can now deform $L_t(\mathbb{T}_+)$ to $(L_0 + t\dot{L}_0)(\mathbb{T}_+)$ such that during the deformation the boundary of the deforming relative cycle does not intersect the boundary of \mathbb{T}_+ . Such deformation again does not alter the intersection number. Now observe that $\Sigma_t := (L_0 + t\dot{L}_0)(\mathbb{T}_+)$ is the portion inside U_{\hbar} of the $(n-1)$ -subspace

$$\boldsymbol{\eta} \mapsto (L_0 + t\dot{L}_0) \begin{bmatrix} 0 \\ \boldsymbol{\eta} \end{bmatrix} = \begin{bmatrix} -t\mathbf{a}\boldsymbol{\eta} \\ \boldsymbol{\eta} \end{bmatrix}.$$

It carries the orientation given by

$$(-t\mathbf{a} du_2 + dv_2) \wedge \cdots \wedge (-t\mathbf{a} du_n + dv_n).$$

Observe that Σ_t intersects the $(n-1)$ -subspace \mathbb{T}_+ given by $\boldsymbol{\xi} = 0$ transversely at the origin, so that

$$\Sigma_t \circ \mathbb{T}_+ = \pm 1.$$

The sign coincides with the sign of the real number ν defined by

$$\begin{aligned} & \nu \, dv_2 \wedge \cdots \wedge dv_n \wedge du_2 \wedge \cdots \wedge du_n \\ &= (-ta \, du_2 + dv_2) \wedge \cdots \wedge (-ta \, du_n + dv_n) \wedge dv_2 \wedge \cdots \wedge dv_n \\ &= (-ta)^{n-1} \, du_2 \wedge \cdots \wedge du_n \wedge dv_2 \wedge \cdots \wedge dv_n \\ &= (-1)^{(n-1)+(n-1)^2} \, dv_2 \wedge \cdots \wedge dv_n \wedge du_2 \wedge \cdots \wedge du_n \end{aligned}$$

Since $(n-1) + (n-1)^2$ is even, we deduce that ν is positive so that

$$1 = \Sigma_t \circ \mathbb{T}_t = \Omega_t(T_+) \circ \mu_t(T_+), \quad \forall 0 < t \ll 1.$$

This completes the proof of the local Picard–Lefschetz formula. \square

Remark 4.30. For a slightly different proof we refer to [Lo]. For a more conceptual proof of the Picard–Lefschetz formula in the case that $n = \dim_{\mathbb{C}} S$ is odd, we refer to [AGV2, Section 2.4]. \square

4.6 Global Picard–Lefschetz Formulæ

Consider a Lefschetz pencil (X_s) on $X \hookrightarrow \mathbb{P}^N$ with associated Lefschetz fibration $\hat{f} : \hat{X} \rightarrow S \cong \mathbb{P}^1$ such that all its critical values t_1, \dots, t_r are situated in the upper hemisphere in $D_+ \subset S$. We denote its critical points by p_1, \dots, p_r , so that

$$\hat{f}(p_j) = t_j, \quad \forall j.$$

We will identify D_+ with the closed unit disk centered at $0 \in \mathbb{C}$. We assume $|t_j| < 1$ for $j = 1, \dots, r$. Fix a point $*$ in ∂D_+ . For $j = 1, \dots, r$ we make the following definitions:

- D_j is a closed disk of very small radius ρ centered at $t_j \in D_+$. If $\rho \ll 1$ these disks are pairwise disjoint.
- $\ell_j : [0, 1] \rightarrow D_+$ is a smooth *embedding* connecting $*$ in ∂D_+ to $t_j + \rho \in \partial D_j$ such that the resulting paths ℓ_1, \dots, ℓ_r are disjoint (see Figure 4.2). Set $k_j := \ell_j \cup D_j$, $\ell = \bigcup \ell_j$ and $k = \bigcup k_j$.
- B_j is a small ball in \hat{X} centered at p_j .

Denote by γ_j the loop in $D_+ \setminus \{t_1, \dots, t_r\}$ based at $*$ obtained by traveling along ℓ_j from $*$ to $t_j + \rho$ and then once counterclockwise around ∂D_j and then back to $*$ along ℓ_j . The loops γ_j generate the fundamental group

$$\pi_1(S^*, *), \quad S^* := S \setminus \{t_1, \dots, t_r\}.$$

Set

$$\hat{X}_{S^*} := \hat{f}^{-1}(S^*).$$

We have a fibration

$$\hat{f} : \hat{X}_{S^*} \rightarrow S^*,$$

and as in the previous section, we have an action

$$\mu : \pi_1(S^*, *) \rightarrow \text{Aut}(H_\bullet(\hat{X}_*, \mathbb{Z}))$$

called *the monodromy of the Lefschetz fibration*. Since X_* is canonically diffeomorphic to \hat{X}_* , we will write X_* instead of \hat{X}_* .

From the proof of the local Picard–Lefschetz formula we deduce that for each critical point p_j of \hat{f} there exists an *oriented* $(n-1)$ -sphere Σ_j embedded in the fiber $X_{t_j+\rho}$ which bounds a *thimble*, i.e., an oriented embedded n -disk $Z_j \subset \hat{X}_+$. This disk is spanned by the family of vanishing spheres in the fibers over the radial path from $t_j + \rho$ to t_j .

We denote by $\Delta_j \in H_{n-1}(X_{t_j+\rho}, \mathbb{Z})$ the homology class determined by the vanishing sphere Σ_j in the fiber over $t_j + \rho$. In fact, using (4.18) we deduce

$$\Delta_j * \Delta_j = (-1)^{n(n-1)/2} \left(1 + (-1)^{n-1} \right) = \begin{cases} 0 & \text{if } n \text{ is even,} \\ -2 & \text{if } n \equiv -1 \pmod{4}, \\ 2 & \text{if } n \equiv 1 \pmod{4}. \end{cases}$$

The above intersection pairing is the one determined by the *complex orientation* of $X_{t_j+\rho}$.

Note that for each j we have a canonical isomorphism

$$H_\bullet(X_j, \mathbb{Z}) \rightarrow H_\bullet(X_*, \mathbb{Z})$$

induced by a trivialization of $\hat{f} : \hat{X}_{S^*} \rightarrow S^*$ over the path ℓ_j connecting $*$ to $t_j + \rho$. This isomorphism is independent of the choice of trivialization since any two trivializations are homotopic. For this reason we will freely identify $H_\bullet(X_*, \mathbb{Z})$ with any $H_\bullet(X_j, \mathbb{Z})$.

Using the local Picard–Lefschetz formula we obtain the following important result.

Theorem 4.31 (Global Picard–Lefschetz formula). *If $z \in H_{n-1}(X_*, \mathbb{Z})$, then*

$$\mathbf{var}_{\gamma_j}(z) := \mu_{\gamma_j}(z) - z = -(-1)^{n(n-1)/2} (z * \Delta_j) \Delta_j.$$

Proof. We prove the result only for the homology with real coefficients, since it contains all the main ideas and none of the technical drag. For simplicity, we set $X_j := X_{t_j+\rho}$. We think of the cohomology $H^\bullet(X_j)$ as the De Rham cohomology of X_j .

Represent the Poincaré dual of z by a closed $(n-1)$ -form ζ on X_j and the Poincaré dual of Δ_j by an $(n-1)$ -form δ_j on X_j . We use the sign conventions⁸

⁸ Given an oriented submanifold $S \subset X_*$ its Poincaré dual should satisfy either $\int_S \omega = \int_{X_*} \omega \wedge \delta_S$ or $\int_S \omega = \int_{X_*} \delta_S \wedge \omega$, $\forall \omega \in \Omega^{\dim S}(X_*)$, $d\omega = 0$. Our sign convention corresponds to first choice. As explained in [Ni, Prop. 7.3.9] this guarantees that for any two oriented submanifolds S_1, S_2 intersecting transversally we have $S_1 * S_2 = \int_{X_*} \delta_{S_1} \wedge \delta_{S_2}$.

of [Ni, Section 7.3], which means that for every closed form $\omega \in \Omega^{n-1}(X_*)$ we have

$$\begin{aligned} \int_{\Sigma_j} \omega &= \int_{X_j} \omega \wedge \delta_j, \\ \Delta_j * z &= \int_{X_j} \delta_j \wedge \zeta = (-1)^{n-1} \int_{X_j} \zeta \wedge \delta_j = (-1)^{n-1} \int_{\Sigma_j} \zeta. \end{aligned}$$

We can assume that δ_j is supported in a small tubular neighborhood U_j of Σ_j in $X_{t_j+\rho}$ diffeomorphic to the unit disk bundle of $T\Sigma_j$.

The monodromy μ_{γ_j} can be represented by a diffeomorphism h_j of X_j that acts trivially outside a compact subset of U_j . In particular, h_j is orientation preserving. We claim that the Poincaré dual of $\mu_{\gamma_j}(z)$ can be represented by the closed form $(h_j^{-1})^*(\zeta)$.

The easiest way to see this is in the special case in which z is represented by an oriented submanifold Z . The cycle $\mu_{\gamma_j}(z)$ is represented by the submanifold $h_j(Z)$ and for every $\omega \in \Omega^{n-1}(X_j)$ we have

$$\begin{aligned} \int_{h_j(Z)} \omega &= \int_Z h_j^* \omega = \int_{X_j} h_j^* \omega \wedge \zeta = \int_{X_j} h_j^* \omega \wedge h_j^* ((h_j^{-1})^* \zeta) \\ &= \int_{X_j} h_j^* (\omega \wedge (h_j^{-1})^* \zeta) = \int_{X_j} \omega \wedge (h_j^{-1})^* \zeta. \end{aligned}$$

At the last step we used the fact that h_j is orientation preserving. As explained in the footnote, the equality

$$\int_{h_j(Z)} \omega = \int_{X_j} \omega \wedge (h_j^{-1})^* \zeta, \quad \forall \omega$$

implies that $(h_j^{-1})^* \zeta$ represents the Poincaré dual of $\mu_{\gamma_j}(z)$.

This is not quite a complete proof of the claim, since there could exist cycles that cannot be represented by embedded, oriented smooth submanifolds. However, the above reasoning can be made into a complete proof if we define carefully the various operations it relies on. We leave the details to the reader (see Exercise 5.37).

Observe that $(h_j^{-1})^* \zeta = \zeta$ outside U_j , so that the difference $(h_j^{-1})^* \zeta - \zeta$ is a closed $(n-1)$ -form with compact support in U_j . It determines an element in $H_{cpt}^{n-1}(U_j)$.

On the other hand, $H_{cpt}^{n-1}(U_j)$ is a one dimensional vector space spanned by the cohomology class carried by δ_j . Hence there exist a real constant c and a form $\eta \in \Omega^{n-2}(U_j)$ with compact support such that

$$(h_j^{-1})^* \zeta - \zeta = c\delta_j + d\eta. \quad (4.24)$$

We have (see [Ni, Lemma 7.3.12])

$$\int_{\nabla_j} \delta_j = \Delta_j * \nabla_j = (-1)^{n-1} \nabla_j * \Delta_j,$$

so that

$$\begin{aligned} (-1)^{n-1} c(\nabla_j * \Delta_j) &= \int_{\nabla_j} c \delta_j = \int_{\nabla_j} ((h_j^{-1})^* \zeta - \zeta) - \int_{\nabla_j} d\eta \\ &= \int_{h_j(\nabla_j) - \nabla_j} \zeta, \end{aligned}$$

where

$$\int_{\nabla_j} d\eta \stackrel{\text{Stokes}}{=} \int_{\partial \nabla_j} \eta = 0,$$

since η has compact support in U_j .

Invoking (4.18) we deduce

$$(\nabla_j * \Delta_j) = (-1)^{n(n-1)/2}.$$

The (piecewise smooth) singular chain $h(\nabla_j) - \nabla_j$ is a *cycle* in U_j representing $\mathbf{var}_{\gamma_j}(\nabla_j) \in H_{n-1}(U_j)$. The local Poincaré–Lefschetz formula shows that this cycle is homologous in U_j (and thus in $X_{t_j+\rho}$ as well) to $(-1)^n \Sigma_j$:

$$\begin{aligned} (-1)^{n+1} c &= (-1)^{n-1} c = (-1)^{n(n-1)/2} \int_{\mathbf{var}_{\gamma_j}(\nabla_j)} \zeta \\ &= (-1)^{n(n-1)/2} \cdot (-1)^n \int_{\Sigma_j} \zeta = (-1)^{n+n(n-1)/2} \Delta_j * z. \end{aligned}$$

Thus

$$c = -(-1)^{n(n-1)/2} (z * \Delta_j).$$

Substituting this value of c in (4.24) and then applying the Poincaré duality, we obtain

$$\mu_j(z) - z = -(-1)^{n(n-1)/2} (z * \Delta_j) \Delta_j. \quad \square$$

Definition 4.32. *The monodromy group of the Lefschetz pencil $(X_s)_{s \in S}$ of X is the subgroup of $\mathfrak{G} \subset \text{Aut}(H_{n-1}(X_*, \mathbb{Z}))$ generated by the monodromies μ_{γ_j} .* \square

Remark 4.33. (a) When $n = 2$, so that the divisors X_s are complex curves (Riemann surfaces), then the monodromy μ_j along an elementary loop ℓ_j is known as a *Dehn twist* associated with the corresponding vanishing sphere. The action of such a Dehn twist on a cycle intersecting the vanishing sphere is depicted in Figure 4.5. The Picard–Lefschetz formula in this case states that the monodromy is a (right-handed) Dehn twist.

(b) Suppose n is odd, so that

$$\Delta_j * \Delta_j = 2(-1)^{(n-1)/2}.$$

Denote by q the intersection form on $L := H_{n-1}(X_*, \mathbb{Z})/\text{Tors}$. It is a *symmetric* bilinear form because $n - 1$ is even. An element $u \in L$ defines the orthogonal reflection $R_u : L \otimes \mathbb{R} \rightarrow L \otimes \mathbb{R}$ uniquely determined by the requirements

$$\begin{aligned} R_u(x) &= x + t(x)u, \quad q\left(u, x + \frac{t(x)}{2}u\right) = 0, \quad \forall x \in L \otimes \mathbb{R} \\ &\iff R_u(x) = x - \frac{2q(x, u)}{q(u, u)}u. \end{aligned}$$

We see that the reflection defined by Δ_j is

$$R_j(x) = x + (-1)^{(n+1)/2}q(x, \Delta_j)\Delta_j = x - (-1)^{n(n-1)/2}q(x, \Delta_j)\Delta_j.$$

This reflection preserves the lattice L , and it is precisely the monodromy along γ_j . This shows that the monodromy group \mathfrak{G} is a group generated by reflections preserving the intersection lattice $H_{n-1}(X_*, \mathbb{Z})/\text{Tors}$. \square

The vanishing submodule

$$\mathbb{V}(X_*) : \text{Image} \left(\partial : H_n(\hat{X}_+, \hat{X}_*; \mathbb{Z}) \rightarrow H_{n-1}(\hat{X}_*, \mathbb{Z}) \right) \subset H_{n-1}(\hat{X}_*, \mathbb{Z})$$

is spanned by the vanishing cycles Δ_j . We can now explain why the invariant cycles are called invariant.

Since $\mathbb{V}(X_*)$ is spanned by the vanishing spheres, we deduce from (4.11) that

$$\mathbb{I}(X_*) := \{ y \in H_{n-1}(X_*, \mathbb{Z}); \quad y * \Delta_j = 0, \quad \forall j \}$$

(use the global Picard–Lefschetz formula)

$$= \{ y \in H_{n-1}(X_*, \mathbb{Z}); \quad \mu_{\gamma_j} y = y, \quad \forall j \}.$$

We have thus proved the following result.

Proposition 4.34. *The module $\mathbb{I}(X_*)$ consists of the cycles invariant under the action of the monodromy group \mathfrak{G} .* \square

Exercises and Solutions

5.1 Exercises

Exercise 5.1. Consider the set

$$\mathcal{Z} = \{ (x, a, b, c) \in \mathbb{R}^4; a \neq 0, ax^2 + bx + c = 0 \}.$$

- (a) Show that \mathcal{Z} is a smooth submanifold of \mathbb{R}^4 .
 (b) Find the discriminant set of the projection

$$\pi : \mathcal{Z} \rightarrow \mathbb{R}^3, \quad \pi(x, a, b, c) = (a, b, c). \quad \square$$

Exercise 5.2. (a) Fix positive real numbers r_1, \dots, r_n , $n \geq 2$, and consider the map

$$\beta : (S^1)^n \rightarrow \mathbb{C}$$

given by

$$(S^1)^n \ni (z_1, \dots, z_n) \mapsto \sum_{i=1}^n r_i z_i \in \mathbb{C}.$$

Show that $x = x + iy$ is a critical value of β if and only if $x^2 = y^2$.

- (b) Consider the open subset M of $(S^1)^n$ described by $\mathbf{Re} \beta > 0$. Show that 0 is a regular value of the function

$$M \ni \mathbf{z} \mapsto \mathbf{Im} \beta(\mathbf{z}) \in \mathbb{R}. \quad \square$$

Exercise 5.3. Suppose $g = g(t_1, \dots, t_n) : \mathbb{R}^n \rightarrow \mathbb{R}$ is a smooth function such that $g(0) = 0$ and

$$dg(0) = c_1 dt_1 + \dots + c_n dt_n, \quad c_n \neq 0.$$

The implicit function theorem implies that near 0 the hypersurface $X = \{g = 0\}$ is described as the graph of a smooth function

$$t_n = t_n(t_1, \dots, t_{n-1}) : \mathbb{R}^{n-1} \rightarrow \mathbb{R}.$$

In other words, we can solve for t_n in the equation $g(t_1, \dots, t_n) = 0$ if $\sum_k |t_k|$ is sufficiently small. Show that there exists a neighborhood V of $0 \in \mathbb{R}^n$ and $C > 0$ such that for every $(t_1, \dots, t_{n-1}, t_n) \in V \cap X$ we have

$$\left| t_n + \frac{c_1 t_1 + \dots + c_{n-1} t_{n-1}}{c_n} \right| \leq C(t_1^2 + \dots + t_{n-1}^2). \quad \square$$

Exercise 5.4 (Raleigh-Ritz). Denote by S^n the unit sphere in \mathbb{R}^{n+1} equipped with the standard Euclidean metric (\bullet, \bullet) . Fix a nonzero symmetric $(n+1) \times (n+1)$ matrix with real entries and define

$$f_A : \mathbb{R}^{n+1} \rightarrow \mathbb{R}, \quad f(\mathbf{x}) = \frac{1}{2}(A\mathbf{x}, \mathbf{x}).$$

Describe the matrices A such that the restriction of f_A to S^n is a Morse function. For such a choice of A find the critical values of f_A , the critical points, and their indices. Compute the Morse polynomial of f_A . \square

Exercise 5.5. For every vector $\boldsymbol{\lambda} = (\lambda_0, \dots, \lambda_n) \in \mathbb{R}^n \setminus 0$ we denote by $f_{\boldsymbol{\lambda}} : \mathbb{C}\mathbb{P}^n \rightarrow \mathbb{R}$ the smooth function

$$f_{\boldsymbol{\lambda}}([z_0, \dots, z_n]) = \frac{\lambda_0 |z_0|^2 + \dots + \lambda_n |z_n|^2}{|z_0|^2 + \dots + |z_n|^2},$$

where $[z_0, \dots, z_n]$ denotes the homogeneous coordinates of a point in $\mathbb{C}\mathbb{P}^n$.

- Find the critical values and the critical points of $f_{\boldsymbol{\lambda}}$.
- Describe for what values of $\boldsymbol{\lambda}$ the critical points of $f_{\boldsymbol{\lambda}}$ are nondegenerate and then determine their indices. \square

Exercise 5.6. Suppose X, Y are two finite dimensional connected smooth manifolds and $f : X \rightarrow Y$ is a smooth map. We say that f is *transversal* to the smooth submanifold S if for every $s \in S$, every $x \in f^{-1}(s)$, we have

$$T_s Y = T_s S + \text{Im}(Df : T_x X \rightarrow T_s Y).$$

- Prove that f is transversal to S if and only if for every $s \in S$, every $x \in f^{-1}(s)$, and every smooth function $u : Y \rightarrow \mathbb{R}$ such that $u|_S = 0$ and $du|_s \neq 0$ we have $f^*(du)|_x \neq 0$.
- Prove that if f is transversal to S , then $f^{-1}(S)$ is a smooth submanifold of X of the same codimension as $S \hookrightarrow Y$. \square

Exercise 5.7. Let X, Y be as in the previous exercise. Suppose A is a smooth, connected manifold. A *smooth family of submanifolds* of Y parametrized by A is a submanifold $\tilde{S} \subset A \times Y$ with the property that the restriction of the natural projection $\pi : A \times Y \rightarrow A$ to \tilde{S} is a submersion $\pi : \tilde{S} \rightarrow A$. For every $\lambda \in A$ we set¹

$$S_\lambda := \{y \in Y; (\lambda, y) \in \tilde{S}\} = \pi^{-1}(\lambda) \cap \tilde{S}.$$

Consider a smooth map

$$F : A \times X \rightarrow Y, \quad A \times X \ni (\lambda, x) \mapsto f_\lambda(x) \in Y$$

and suppose that the induced map

$$G : A \times X \rightarrow A \times Y, \quad (\lambda, x) \mapsto (\lambda, f_\lambda(x))$$

is transversal to \tilde{S} .

Prove that there exists a subset $A_0 \subset A$ of measure zero such that for every $\lambda \in A \setminus A_0$ the map $f_\lambda : X \rightarrow Y$ is transversal to S_λ . \square

Remark 5.8. If we let $\tilde{S} = \{y_0\} \times A$ in the above exercise we deduce that for generic λ the point y_0 is a regular value of f_λ provided it is a regular value of F . \square

Exercise 5.9. Denote by (\bullet, \bullet) the Euclidean metric on \mathbb{R}^{n+1} . Suppose $M \subset \mathbb{R}^{n+1}$ is an *oriented* connected smooth submanifold of dimension n . This implies that we have a smoothly varying unit normal vector field \mathcal{N} along M , which we interpret as a smooth map from M to the *unit sphere* $S^n \subset \mathbb{R}^{n+1}$,

$$\mathcal{N} = \mathcal{N}_M : M \rightarrow S^n.$$

This is known as the *Gauss map* of the embedding $M \hookrightarrow \mathbb{R}^{n+1}$.

For every unit vector $\mathbf{v} \in S^n \subset \mathbb{R}^{n+1}$ we denote by $\ell_{\mathbf{v}} : \mathbb{R}^{n+1} \rightarrow \mathbb{R}$ the linear function

$$\ell_{\mathbf{v}}(\mathbf{x}) = (\mathbf{v}, \mathbf{x}).$$

Show that the restriction of $\ell_{\mathbf{v}}$ to M is a Morse function if and only if the vector $\mathbf{v} \in S^n$ is a regular value of the Gauss map \mathcal{N} . \square

Exercise 5.10. Suppose $\Sigma \hookrightarrow \mathbb{R}^3$ is a compact *oriented* surface without boundary and consider the Gauss map

$$\mathcal{N}_\Sigma : \Sigma \rightarrow S^2$$

¹ Note that the collection $(S_\lambda)_{\lambda \in A}$ is indeed a family of smooth submanifolds of Y .

defined as in the previous exercise. Denote by $(\bullet, \bullet) : \mathbb{R}^3 \times \mathbb{R}^3 \rightarrow \mathbb{R}$ the canonical inner product. Recall that in Corollary 1.25 we showed that there exists a set $\Delta \subset S^2$ of measure zero such that for all $u \in S^2 \setminus \Delta$ the function

$$\ell_u : \Sigma \rightarrow \mathbb{R}, \quad \ell_u(x) = (u, x)$$

is a Morse function. For every $u \in S^2 \setminus \Delta$ and any open set $V \subset \Sigma$ we denote by $\mathbf{Cr}_u(U)$ the set of critical points of ℓ_u situated in U . Define

$$\chi_u(V) := \sum_{x \in \mathbf{Cr}_u(U)} (-1)^{\lambda(\ell_u, x)}$$

and

$$m(U) := \frac{1}{\text{area } S^2} \int_{S^2 \setminus \Delta} \chi_u(V) d\sigma(u) = \frac{1}{4\pi} \int_{S^2 \setminus \Delta} \chi_u(V) d\sigma(u).$$

Denote by $s : \Sigma \rightarrow \mathbb{R}$ the scalar curvature of the metric g on Σ induced by the Euclidean metric on \mathbb{R}^3 and by dV_{S^2} the volume form on the unit sphere S^2 . Show that

$$m(U) = \frac{1}{4\pi} \int_U \mathcal{N}_\Sigma^* dV_{S^2} = \frac{1}{4\pi} \int_U s(x) dV_g(x).$$

In particular, conclude that

$$\chi(\Sigma) = \frac{1}{4\pi} \int_\Sigma s(x) dV_g(x). \quad \square$$

Exercise 5.11. Suppose $\Sigma \hookrightarrow \mathbb{R}^3$ is a compact *oriented* surface without boundary. The orientation on Σ defines smooth unit normal vector field

$$\mathbf{n} : \Sigma \rightarrow S^2, \quad \mathbf{n}(p) \perp T_p \Sigma, \quad \forall p \in \Sigma.$$

For every $u \in \mathbb{R}^3$ we denote by q_u the function

$$q_u : \Sigma \rightarrow \mathbb{R}, \quad q_u(x) = \frac{1}{2}|x - u|^2.$$

We denote by \mathcal{S} the set $u \in \mathbb{R}^3$ such that the function q_u is a Morse function. We know that $\mathbb{R}^3 \setminus \mathcal{S}$ has zero Lebesgue measure.

(a) Show that $p \in \Sigma$ is a critical point of q_u if and only if there exists $t \in \mathbb{R}$ such that $u = p + t\mathbf{n}(p)$.

(b) Let $u \in \mathbb{R}^3$ and suppose $p \in \Sigma$ is a critical point of q_u . Denote by $g : T_p \Sigma \times T_p \Sigma \rightarrow \mathbb{R}$ the *first fundamental form* of $\Sigma \hookrightarrow \mathbb{R}^3$ at p , i.e., the induced inner product on $T_p \Sigma$, and by $a : T_p \Sigma \times T_p \Sigma \rightarrow \mathbb{R}$ the second fundamental form (see [Str, 2.5]) of $\Sigma \hookrightarrow \mathbb{R}^3$ at p . These are symmetric bilinear forms. For every $t \in \mathbb{R}$ we denote by $\nu_p(t)$ the nullity of the symmetric bilinear form

$g - ta$. Since p is a critical point of q_u there exists $t_u = t_u(p) \in \mathbb{R}$ such that $u = p + t_u \mathbf{n}(p)$. Show that p is a nondegenerate critical point of q_u if and only if $\nu(t_u) \neq 0$. In this case, the index of q_u at p is

$$\lambda(q_u, p) = \sum_{t \in I_u(p)} \nu(t),$$

where $I_u(p)$ denotes the interval consisting of all real numbers strictly between 0 and $t_u(p)$.

(c)* For every $u \in \mathcal{S}$ and every $p \in \Sigma$ we set

$$e(u, p) := \begin{cases} (-1)^{\lambda(u, p)} & p \text{ critical point of } q_u, \\ 0 & p \text{ regular point of } q_u. \end{cases}$$

For $r > 0$ and $U \subset \Sigma$ an open subset of Σ we define

$$\mu_r(U) = \int_{\mathbb{R}^3} \left(\sum_{p \in U, |p-u| < r} e(u, p) \right) du.$$

Show that there exist nonzero *universal constants* c_1, c_2 such that

$$\mu_r(U) = c_1 r \left(\int_U dV_g \right) r + c_2 \left(\int_U s_g dV_g \right) r^3$$

for all r sufficiently small. Above dV_g denotes the area form on Σ while s_g denotes the scalar curvature of the induced metric g on Σ . If $U = D_\varepsilon(p_0)$ is a geodesic disk of radius ε centered at $p_0 \in \Sigma$, then

$$\lim_{\varepsilon \searrow 0} \frac{1}{\text{area}_g(D_\varepsilon(p_0))} \mu_r(D_\varepsilon(p_0)) = c_1 r + c_3 r^3 s_g(p_0), \quad \forall 0 < r \ll 1.$$

□

Exercise 5.12. Prove the equality (2.1).

Exercise 5.13. Consider the group G described by the presentation

$$G = \langle a, b \mid aba = bab, a^2b^2 = aba^{-1}ba \rangle.$$

- (a) Show that $ab^3a^{-1} = b^2$, $b^3 = ba^2b^{-1}$, and $a^2 = b^3$.
 (b) Show that G is isomorphic to the group

$$H = \langle x, y \mid x^3 = y^5 = (xy)^2 \rangle.$$

- (c) Show that H is a finite group.

□

Exercise 5.14. Suppose M is a compact, orientable smooth 3-dimensional manifold whose integral homology is isomorphic to the homology of S^3 and $f : M \rightarrow \mathbb{R}$ is a Morse function.

- (a) Prove that f has an even number of critical points.
- (b) Construct a Morse function on $S^1 \times S^2$ that has exactly 4 critical points.
- (c) A theorem of G. Reeb [Re] (see also [M1, M3]) states that M is homeomorphic to S^3 if and only if there exists a Morse function on M with exactly two critical points. Prove that if $H_\bullet(M, \mathbb{Z}) \cong H_\bullet(S^3, \mathbb{Z})$ but $\pi_1(M) \neq \{1\}$ (e.g., M is the Poincaré sphere), then any Morse function on M has at least 6 critical points. \square

Remark 5.15. Part (c) is true under the weaker assumption that $H_\bullet(M, \mathbb{Z}) \cong H_\bullet(S^3, \mathbb{Z})$ but M is not homeomorphic to S^3 . This follows from Poincaré's conjecture whose validity was recently established by G. Perelman, which shows that $M \cong S^3 \iff \pi_1(M) = \{1\}$. However, this result is not needed in proving the stronger version of (c). One immediate conclusion of this exercise is that the manifold M *does not admit perfect Morse functions!!!* \square

Exercise 5.16. Consider a knot K in \mathbb{R}^3 , i.e., a smoothly embedded circle $S^1 \hookrightarrow \mathbb{R}^3$. Suppose there exists a unit vector $u \in \mathbb{R}^3$ such that the function

$$\ell_u : K \rightarrow \mathbb{R}, \quad \ell_u(x) = (u, x) = \text{inner product of } u \text{ and } x$$

is a function with only two critical points, a global minimum and a global maximum. Prove that K must be the unknot. In particular, we deduce that the restriction of any linear function on a *nontrivial* knot in \mathbb{R}^3 must have more than two critical points!

Exercise 5.17. Construct a Morse function $f : S^2 \rightarrow \mathbb{R}$ with the following properties:

- (a) f is nonresonant, i.e., no level set $\{f = \text{const}\}$ contains more than one critical point.
- (b) f has at least four critical points.
- (c) There exist orientation preserving diffeomorphisms $R : S^2 \rightarrow S^2$, $L : \mathbb{R} \rightarrow \mathbb{R}$ such that

$$-f = L \circ f \circ R. \quad \square$$

Exercise 5.18 (Harvey–Lawson). Consider the unit sphere

$$S^2 = \{(x, y, z) \in \mathbb{R}^3; x^2 + y^2 + z^2 = 1\}$$

and the smooth function $f : S^2 \rightarrow \mathbb{R}$, $f(x, y, z) = z$. Denote by N the north pole $N = (0, 0, 1)$.

- (a) Find the critical points of f .

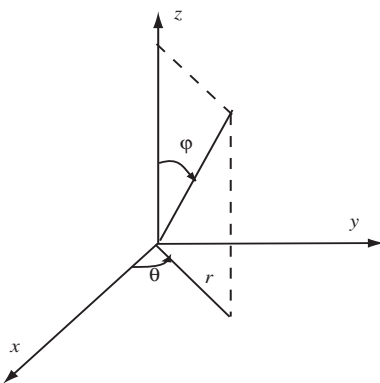

Fig. 5.1. Cylindrical coordinates.

(b) Denote by g the Riemannian metric on S^2 induced by the canonical Euclidean metric $g_0 = dx^2 + dy^2 + dz^2$ on \mathbb{R}^3 . Denote by ω_g the volume form on S^2 induced by g and the orientation of S^2 as boundary² of the unit ball. Describe g and ω_g in cylindrical coordinate (θ, z) (see Figure 5.1):

$$x = r \cos \theta, \quad y = r \sin \theta, \quad r = \sqrt{1 - z^2}, \quad \theta \in [0, 2\pi], \quad z \in [-1, 1].$$

(c) Denote by ∇f the gradient of f with respect to the metric g . Describe ∇f in the cylindrical coordinates (θ, z) and then describe the negative gradient flow

$$\frac{dp}{dt} = -\nabla f(p) \tag{5.1}$$

as a system of ODEs of the type

$$\begin{cases} \dot{\theta} = A(\theta, z) \\ \dot{z} = B(\theta, z) \end{cases},$$

where A, B are smooth functions of two variables, and the dot denotes differentiation with respect to the time variable t .

(d) Solve the system of ODEs found at (c).

(e) Denote by $\Phi_t : S^2 \rightarrow S^2$, $t \in \mathbb{R}$, the one parameter group of diffeomorphisms of S^2 determined by the gradient flow³ (5.1) and set $\omega_t := \Phi_t^* \omega_g$. Show that for every $t \in \mathbb{R}$ we have

$$\int_{S^2} \omega_t = \int_{S^2} \omega_g$$

² We are using the *outer-normal-first* convention.

³ In other words, for every $p \in S^2$ the path $t \mapsto \Phi_t(p)$ is a solution of (5.1).

and there exists a smooth function $\lambda_t : S^2 \rightarrow (0, \infty)$ that depends only on the coordinate z such that

$$\omega_t = \lambda_t \cdot \omega_g, \quad \lim_{t \rightarrow \infty} \lambda_t(p) = 0, \quad \forall p \in S^2 \setminus N.$$

Sketch the graph of the function λ_t for $|t|$ very large.

(f) Show that for every smooth function $u : S^2 \rightarrow \mathbb{R}^2$ we have

$$\lim_{t \rightarrow \infty} \int_{S^2} u \cdot \omega_t = u(N) \int_{S^2} \omega_g \quad (5.2)$$

and then give a geometrical interpretation of the equality (5.2). \square

Exercise 5.19. Suppose V is a finite dimensional real Euclidean space. We denote the inner product by $\langle \bullet, \bullet \rangle$. We define an inner product on the space $\text{End}(V)$ of endomorphisms of V by setting

$$\langle S, T \rangle : \text{tr}(ST^*).$$

Denote by $SO(V) \subset \text{End}(V)$ the group of orthogonal endomorphisms of determinant one, by $\text{End}_+(V)$ the subspace of symmetric endomorphisms, and by $\text{End}_-(V)$ the subspace of skew-symmetric endomorphisms.

(a) Show that $\text{End}_-(V)$ is the orthogonal complement of $\text{End}_+(V)$ with respect to the inner product $\langle \bullet, \bullet \rangle$.

(b) Let $A \in \text{End}_+(V)$ be a symmetric endomorphism with distinct *positive* eigenvalues. Define

$$f_A : SO(V) \rightarrow \mathbb{R}, \quad T \mapsto -\langle A, T \rangle.$$

Show that f_A is a Morse function with 2^{n-1} critical points, where $n = \dim V$ and then compute their indices.

(c) Show that the Morse polynomial of f_A is

$$P_n(t) = (1+t) \cdots (1+t^{n-1}). \quad \square$$

Remark 5.20. As explained in [Ha, Theorem 3D.2] the polynomial

$$(1+t) \cdots (1+t^{n-1})$$

is the Poincaré polynomial of $SO(n)$ with $\mathbb{Z}/2$ coefficients. This shows that the function f_A is a $\mathbb{Z}/2$ -perfect Morse function. \square

Exercise 5.21. Let V and $A \in \text{End}(V)$ be as in Exercise 5.19. For every $S \in SO(V)$ we have an isomorphism

$$T_S SO(V) \rightarrow T_{\mathbb{1}} SO(V), \quad X \mapsto XS^{-1}.$$

We have a natural metric g on $SO(V)$ induced by the metric $\langle \bullet, \bullet \rangle$ on $\text{End}(V)$.

(a) Show that for every $S \in SO(V)$ we have

$$2\nabla^g f_A(S) = -A^* + ASA.$$

(b) Show that the Cayley transform

$$X \mapsto \mathfrak{Y}(X) := (\mathbb{1} - X)(\mathbb{1} + X)^{-1}$$

defines a bijection from the open neighborhood \mathcal{U} of $\mathbb{1} \in SO(V)$ consisting of orthogonal transformations S such that $\det(\mathbb{1} + S) \neq 0$ to the open neighborhood \mathcal{O} of $0 \in \text{End}_-(V)$ consisting of skew-symmetric matrices Y such that $\det(\mathbb{1} + Y) \neq 0$.

(c) Suppose S_0 is a critical point of f_A . Set $\mathcal{U}_{S_0} = \mathcal{U}_{S_0}$. Then \mathcal{U}_{S_0} is an open neighborhood of $S_0 \in SO(V)$, and we get a diffeomorphism

$$\mathfrak{Y}_{S_0} : \mathcal{U}_{S_0} \rightarrow \mathcal{O}, \quad \mathcal{U}_{S_0} \ni T \mapsto \mathfrak{Y}(TS_0^{-1}),$$

Thus we can regard the map \mathfrak{Y}_{S_0} as defining local coordinates Y near S_0 . Show that in these local coordinates the gradient flow of f_A has the description

$$\dot{Y} = AS_0Y - YAS_0.$$

(d) Show that for every orthogonal matrix S_0 , the flow line through S_0 of the gradient vector field $2\nabla^g f_A$ is given by

$$t \mapsto \left(\sinh(-At) + \cosh(-At)S_0 \right) \left(\cosh(-At) + \sinh(-At)S_0 \right)^{-1}. \quad \square$$

Exercise 5.22. Suppose V is a finite dimensional complex Hermitian vector space of dimension n . We denote the Hermitian metric by $\langle \bullet, \bullet \rangle$, the corresponding norm by $|\bullet|$, and the unit sphere by $S = S(V)$. For every integer $0 < k < \dim V$ we denote by $G_k(V)$ the Grassmannian of complex k -dimensional subspaces in V . For every $L \in G_k(V)$ we denote by $P_L : V \rightarrow V$ the orthogonal projection onto L and by L^\perp the orthogonal complement. We topologize $G_k(V)$ using the metric

$$d(L_1, L_2) = \|P_{L_1} - P_{L_2}\|.$$

Suppose $L \in G_k(V)$ and $S : L \rightarrow L^\perp$ is a linear map. Denote by $\Gamma_S \in G_k(V)$ the graph of the operator S , i.e., the subspace

$$\Gamma_S = \{x + Sx; x \in L\} \subset L \oplus L^\perp = V.$$

We thus have a map

$$\text{Hom}(L, L^\perp) \ni S \mapsto \Gamma_S \in G_k(V).$$

(a) Show that for every $S \in \text{Hom}(L, L^\perp)$ we have

$$\Gamma_S^\perp = \{-y + S^*y; y \in L^\perp\} \subset L^\perp \oplus L,$$

where $S^* : L^\perp \rightarrow L$ is the adjoint operator.

(b) Describe P_{Γ_S} in terms of P_L and S . For $t \in \mathbb{R}$ set $L_t = \Gamma_{tS}$. Compute $\frac{d}{dt}|_{t=0} P_{L_t}$.

(c) Prove that the map

$$\text{Hom}(L, L^\perp) \ni S \mapsto \Gamma_S \in G_k(V)$$

is a homeomorphism onto the *open* subset of $G_k(V)$ consisting of all k -planes intersecting L^\perp transversally. In particular, its inverse defines local coordinates on $G_k(V)$ near $L = \Gamma_{S=0}$. We will refer to these as *graph coordinates*.

(d) Show that for every $L \in G_k(V)$ the tangent space $T_L G_k(V)$ is isomorphic to the space of symmetric operators $\dot{P} : V \rightarrow V$ satisfying

$$\dot{P}(L) \subset L^\perp, \quad \dot{P}L^\perp \subset L.$$

Given \dot{P} as above, construct a linear operator $S : L \rightarrow L^\perp$ such that

$$\frac{d}{dt}|_{t=0} P_{\Gamma_{tS}} = \dot{P}. \quad \square$$

Exercise 5.23. Assume that $A : V \rightarrow V$ is a Hermitian operator with simple eigenvalues. Define

$$h_A : G_k(V) \rightarrow \mathbb{R}, \quad h_A(T) = -\mathbf{Re} \, \text{tr} \, AP_L.$$

(a) Show that L is a critical point of h_A if and only if $AL \subset L$.

(b) Show that h_A is a perfect Morse function and then compute its Morse polynomial. □

Remark 5.24. The stable and unstable manifolds of the gradient flow of h_A with respect to the metric $g(\dot{P}, \dot{Q}) = \mathbf{Re} \, \text{tr}(\dot{P}, \dot{Q})$ coincide with some classical objects, the Schubert cycles of a complex Grassmannian. □

Exercise 5.25. Suppose V is an n -dimensional real Euclidean space with inner product (\bullet, \bullet) and $A : V \rightarrow V$ is a selfadjoint endomorphism. We set

$$S(V) := \{v \in V; |v| = 1\}$$

and define

$$f_A : S(V) \rightarrow \mathbb{R}, \quad f(v) = (Av, v).$$

For $1 \leq k \leq n = \dim V$ we denote by $G_k(V)$ the Grassmannian of k -dimensional vector subspaces of V and we set

$$\lambda_k = \lambda_k(A) := \min_{E \in G_k(V)} \max_{v \in E \cap S(V)} f_A(v).$$

Show that

$$\lambda_1(A) \leq \lambda_2(A) \leq \cdots \leq \lambda_n(A)$$

and that any critical value of f_A is equal to one of the λ_k 's. \square

Exercise 5.26. Suppose V is a vector space equipped with a symplectic pairing

$$\omega : V \times V \rightarrow \mathbb{R}.$$

Denote by $I_\omega : V \rightarrow V^*$ the induced isomorphism. For every subspace $L \subset V$ we define its *symplectic annihilator* to be

$$L^\omega := \{v \in V; \omega(v, x) = 0 \quad \forall x \in L\}.$$

(a) Prove that

$$I_\omega L^\omega = L^\perp = \{\alpha \in V^*; \langle \alpha, v \rangle = 0, \quad \forall v \in L\}.$$

Conclude that $\dim L + \dim L^\omega = \dim V$.

(b) A subspace $L \subset V$ is called *isotropic* if $L \subset L^\omega$. An isotropic subspace is called *Lagrangian* if $L = L^\omega$. Show that if L is an isotropic subspace then

$$0 \leq \dim L \leq \frac{1}{2} \dim V$$

with equality if and only if L is lagrangian.

(c) Suppose L_0, L_1 are two Lagrangian subspaces of V such that $L_0 \cap L_1 = (0)$. Show that the following statements are equivalent.

(c1) L is a Lagrangian subspace of V transversal to L_1 .

(c2) There exists a linear operator $A : L_0 \rightarrow L_1$ such that

$$L = \{x + Ax; \quad x \in L_0\}$$

and the bilinear form

$$Q : L_0 \times L_0 \rightarrow \mathbb{R}, \quad Q(x, y) = \omega(x, Ay)$$

is symmetric. We will denote it by $Q_{L_0, L_1}(L)$.

(d) Show that if L is a Lagrangian intersecting L_1 transversally, then L intersects L_0 transversally if and only if the symmetric bilinear form $Q_{L_0, L_1}(L)$ is nondegenerate. \square

Exercise 5.27. Consider a smooth n -dimensional manifold M . Denote by E the total space of the cotangent bundle $\pi : T^*M \rightarrow M$ and by $\theta = \theta_M$ the canonical 1-form on E described in local coordinates $(\xi_1, \dots, \xi_m, x^1, \dots, x^m)$ by

$$\theta = \sum_i \xi_i dx^i.$$

Let $\omega = -d\theta$ denote the canonical symplectic structure on E . A submanifold $L \subset E$ is called *Lagrangian* if for every $x \in L$ the tangent subspace $T_x L$ is a Lagrangian subspace of $T_x E$.

(a) A smooth function f on M defines a submanifold Γ_{df} of E , the graph of the differential. In local coordinates $(\xi_i; x^j)$ it is described by

$$\xi_i = \partial_{x^i} f(x).$$

Show that Γ_{df} is a Lagrangian submanifold of E .

(b) Suppose $x \in M$ is a critical point of M . We regard M as a submanifold of E embedded as the zero section of T^*M . We identify $x \in M$ with $(0, x) \in T^*M$. Set

$$L_0 = T_x^M \subset T_{(0,x)}E, \quad L_1 = T_x^*M \subset T_{(0,x)}E, \quad L = T_{(0,x)}\Gamma_{df} \subset T_{(0,x)}E.$$

They are all Lagrangian subspaces of $V = T_{(0,x)}E$. Clearly $L_0 \pitchfork L_1$ and $L \pitchfork L_1$. Show that

$$Q_{L_0, L_1}(L) = \text{the Hessian of } f \text{ at } x \in M. \quad (5.3)$$

(c) A Lagrangian submanifold L of E is called *exact* if the restriction of θ to L is exact. Show that Γ_{df} is an exact Lagrangian submanifold.

(d) Suppose H is a smooth real valued function on E . Denote by X_H the Hamiltonian vector field associated with H and the symplectic form $\omega = -d\theta$. Show that in the local coordinates (ξ_i, x^j) we have

$$X_H = \sum_i \frac{\partial H}{\partial \xi_i} \partial_{x^i} - \sum_j \frac{\partial H}{\partial x^j} \partial_{\xi_j}.$$

Show that if L is an exact Lagrangian submanifold of E , then so is $\Phi_t^H(L)$ for any $t \in \mathbb{R}$. \square

Exercise 5.28. We fix a diffeomorphism

$$\mathbb{R} \times S^1 \rightarrow T^*S^1, \quad (\xi, \theta) \mapsto (\xi d\theta, \theta),$$

so that the canonical symplectic form on T^*S^1 is given by

$$\omega = d\theta \wedge d\xi.$$

Denote by $L_0 \subset T^*S^1$ the zero section.

- (a) Construct a compact Lagrangian submanifold of T^*S^1 that does not intersect L_0 .
 (b) Show that any compact, *exact Lagrangian*, oriented submanifold L of T^*S^1 intersects L_0 in at least two points. \square

Remark 5.29. The above result is a very special case of Arnold's conjecture stating that if M is a compact smooth manifold then any exact Lagrangian submanifold T^*M must intersect the zero section in at least as many points as the number of critical points of a smooth function on M . In particular, if an exact Lagrangian intersects the zero section transversally, then the geometric number of intersection points is no less than the sum of Betti numbers of M . \square

Exercise 5.30. Consider the tautological right action of $SO(3)$ on its cotangent bundle

$$T^*SO(3) \times SO(3) \ni (\varphi, h; g) \mapsto (R_{g^{-1}}^* \varphi, R_g(h) = hg),$$

where

$$R_{g^{-1}}^* : T_{gh}SO(3) \rightarrow T_hSO(3)$$

is the pullback map. Show that this action is Hamiltonian with respect to the tautological symplectic form on $T^*SO(3)$ and then compute its moment map

$$\mu : T^*SO(3) \rightarrow \underline{so}(3)^*. \quad \square$$

Exercise 5.31. Consider the complex projective space $\mathbb{C}\mathbb{P}^n$ with projective coordinates $\mathbf{z} = [z^0, \dots, z^n]$.

- (a) Show that the Fubini–Study form

$$\omega = i\partial\bar{\partial} \log |\mathbf{z}|^2, \quad |\mathbf{z}|^2 = \sum_{k=0}^n |z_k|^2$$

defines a symplectic structure on $\mathbb{C}\mathbb{P}^n$.

- (b) Show that the action of S^1 on $\mathbb{C}\mathbb{P}^n$ given by

$$e^{it} \cdot [z_0, \dots, z_n] = [z^0, e^{it} z_1, e^{2it} z_2, \dots, e^{nit} z_n]$$

is Hamiltonian and then find a moment map for this action. \square

Exercise 5.32. Let (M, ω) be a compact toric manifold of dimension $2n$ and denote by \mathbb{T} the n -dimensional torus acting on M .

- (a) Prove that the top dimensional orbits of \mathbb{T} are Lagrangian submanifolds.
 (b) Prove that the set of points in M with trivial stabilizers is open and dense. \square

Exercise 5.33. (a) Let \mathbb{T} be a compact torus of real dimension n with Lie algebra \mathfrak{t} . A *character* of \mathbb{T}^n is by definition a continuous group morphism $\chi : \mathbb{T} \rightarrow S^1$. We denote by $\hat{\mathbb{T}}$ set of characters of \mathbb{T} . Then $\hat{\mathbb{T}}$ is an Abelian group with respect to the operation

$$(\chi_1 \cdot \chi_2)(t) := \chi_1(t) \cdot \chi_2(t), \quad \forall t \in \mathbb{T}, \quad \chi_1, \chi_2 \in \hat{\mathbb{T}}.$$

(a) Show that the natural map

$$(\hat{\mathbb{T}}, \cdot) \ni \chi \longmapsto (d\chi)|_{t=1} \in (\mathfrak{t}^*, +)$$

is an injective group morphism whose image is a *lattice* of \mathfrak{t}^* , i.e., it is a free Abelian group of rank n that spans \mathfrak{t}^* as a vector space. We denote this lattice by Λ^\vee .

(b) The quotient $\mathfrak{t}^*/\Lambda^\vee$ is an n -dimensional torus, called the *dual* of \mathbb{T} and denoted by \mathbb{T}^\vee . There exists a unique translation invariant measure λ on \mathfrak{t}^* such that the volume of the quotient $\mathfrak{t}^*/\Lambda^\vee$ is equal to 1. Equivalently, λ is the Lebesgue measure on \mathbb{T}^* normalized by the requirement that the volume of the fundamental parallelepiped of Λ^\vee be equal to 1. Suppose we are given an *effective* Hamiltonian action of \mathbb{T} of a compact symplectic manifold (M, ω) of dimension $2n = 2 \dim \mathbb{T}$. Denote by μ a moment map of this action. Show that

$$\int_M \frac{1}{n!} \omega^n = \text{vol}_\lambda(\mu(M)). \quad \square$$

Exercise 5.34. Prove that there exists no smooth effective action of S^1 on a compact oriented Riemann surface Σ of genus $g \geq 2$. □

Exercise 5.35. Let $G = \{\pm 1\}$ denote the (multiplicative) cyclic group of order two, and \mathbb{F}_2 denote the field with two elements. Then G acts on S^∞ by reflection in the center of the sphere. The quotient is the infinite dimensional real projective space $\mathbb{R}P^\infty$. The cohomology ring of $\mathbb{R}P^\infty$ with coefficients in \mathbb{F}_2 is

$$H^\bullet(\mathbb{R}P^\infty, \mathbb{F}_2) \cong R := \mathbb{F}_2[t], \quad \deg t = 1.$$

For every continuous action of G on a locally compact space X we set

$$X_G := (S^\infty \times X)/G,$$

where G acts by

$$t \cdot (v, x) = (t \cdot v, t^{-1}x), \quad \forall t \in G, \quad v \in S^\infty, \quad x \in X.$$

Set

$$H_G(X) := H^\bullet(X_G, \mathbb{F}_2).$$

Observe that we have a fibration

$$X \hookrightarrow X_G \rightarrow \mathbb{R}\mathbb{P}^\infty,$$

and thus $H_G(X)$ has a natural structure of an R -module. Similarly, if Y is a closed, G -invariant subset of X we define

$$H_G(X, Y) := H^\bullet(X_G, Y_G; \mathbb{F}_2).$$

A *finitely generated* R -module M is called *negligible* if the \mathbb{F}_2 -linear endomorphism

$$t : M \rightarrow M, \quad m \mapsto t \cdot m,$$

is nilpotent.

(a) Show that if G acts freely on the compact space X then $H_G(X)$ is negligible.

(b) Suppose X is a compact smooth manifold and G acts smoothly on X . Denote by $\text{Fix}_G(X)$ the fixed point set of this action. Show that F is a compact smooth manifold. Show that $H_G(X, \text{Fix}_G(X))$ is negligible.

(c) Prove that

$$\sum_{k \geq 0} \dim_{\mathbb{F}_2} H^k(\text{Fix}_G(X), \mathbb{F}_2) \leq \sum_{k \geq 0} \dim_{\mathbb{F}_2} H^k(X, \mathbb{F}_2). \quad \square$$

Exercise 5.36. Consider a homogeneous polynomial $P \in \mathbb{R}[x, y, z]$ of degree d . Define

$$X(P) := \{ [x, y, z] \in \mathbb{R}\mathbb{P}^2; P(x, y, z) = 0 \}.$$

For generic P , the locus $X(P)$ is a smooth submanifold of $\mathbb{R}\mathbb{P}^2$ of dimension 1, i.e., $X(P)$ is a disjoint union of circles (ovals). Denote by $n(P)$ the number of these circles. Show that

$$n(P) \leq 1 + \frac{(d-1)(d-2)}{2}. \quad \square$$

Exercise 5.37. Suppose M is a compact, connected, orientable, smooth manifold without boundary. Set $m := \dim M$ Fix an orientation \mathbf{or} on M . Denote by $H^\bullet(M)$ the De Rham cohomology of M . For $0 \leq k \leq m$ we set

$$H_k(M) := \text{Hom}(H^k(M), \mathbb{R}).$$

The *Kronecker pairing*

$$\langle -, - \rangle : H^k(M) \times H_k(M) \rightarrow \mathbb{R}, \quad H^k(M) \times H_k(M) \ni (\alpha, z) \mapsto \langle \alpha, z \rangle$$

is the natural pairing between a vector space and its dual.

The orientation \mathbf{or}_M determines an element $[M] \in H_m(M)$ via

$$\langle \alpha, [M] \rangle := \int_M \eta_\alpha,$$

where η_α denotes an m -form on M whose De Rham cohomology class is α .

Observe that we have a natural map

$$PD : H^{m-k}(M) \rightarrow H_k(M),$$

so that for $\alpha \in H^{m-k}(M)$ the element $PD(\alpha) \in H_k(M)$ is defined by

$$\langle \beta, PD(\alpha) \rangle := \langle \alpha \cup \beta, [M] \rangle.$$

The Poincaré duality theorem states that this map is an isomorphism.

A smooth map $\phi : M \rightarrow M$ induces a linear map $\phi_* : H_\bullet(M) \rightarrow H_\bullet(M)$ defined by the commutative diagram

$$\begin{array}{ccc} H^\bullet(M) & \xrightarrow{\phi^*} & H^\bullet(M) \\ PD \downarrow & & \downarrow PD \\ H_\bullet(M) & \xrightarrow{\phi_*} & H_\bullet(M) \end{array}$$

(a) Show that if ϕ is a diffeomorphism, then for every $\alpha \in H^\bullet(M)$ and every smooth map ϕ of M we have

$$\phi_*(PD\alpha) = (\deg \phi) \cdot PD((\phi^{-1})^*\alpha).$$

(b) Suppose S is a compact *oriented* submanifold of M of dimension k . Then S determines an element $[S]$ of $H_k(M)$ via

$$\langle \alpha, [S] \rangle = \int_S \eta_\alpha, \quad \forall \alpha$$

where η_α denotes a closed k -form representing the De Rham cohomology class α . Any diffeomorphism $\phi : M \rightarrow M$ determines a new *oriented* submanifold $\phi(S)$ in an obvious fashion. Show that

$$\phi_*[S] = [\phi(S)].$$

Exercise 5.38. Consider two homogeneous cubic polynomials in the variables (z_0, z_1, z_2) . The equation

$$t_0^n A_0(z_0, z_1, z_2) + t_1^n A_1(z_0, z_1, z_2) = 0$$

defines a hypersurface Y_n in $\mathbb{P}^2 \times \mathbb{P}^1$.

(a) Show that for generic A_0, A_1 the hypersurface Y_n is smooth.

- (b) Show that for generic A_0, A_1 the natural map $Y_n \rightarrow \mathbb{P}^1$ induced by the projection $\mathbb{P}^2 \times \mathbb{P}^1 \rightarrow \mathbb{P}^1$ is a nonresonant Morse map.
- (c) Show that for generic A_0, A_1 the hypersurface Y_1 is biholomorphic to the blowup of \mathbb{P}^2 at the nine points of intersection of the cubic $\{A_0 = 0\}$ and $\{A_1 = 1\}$. (See Example 4.5.)
- (d) Using the computations in Example 4.15 deduce that for generic A_0, A_1 the map $X_n \rightarrow \mathbb{P}^1$ has precisely $12n$ critical points. Conclude that

$$\chi(X_n) = 12n.$$

- (e) Describe the above map $X_n \rightarrow \mathbb{P}^1$ as a Lefschetz fibration (see Definition 4.2) using the *Segre embeddings*

$$\mathbb{P}^k \times \mathbb{P}^m \rightarrow \mathbb{P}^{(k+1)(m+1)-1},$$

$$\mathbb{P}^k \times \mathbb{P}^m \ni ([x_i]_{0 \leq i \leq k}, [y_j]_{0 \leq j \leq m}) \mapsto [(x_i y_j)_{0 \leq i \leq k, 0 \leq j \leq m}] \in \mathbb{P}^{(k+1)(m+1)-1}.$$

5.2 Solutions to Selected Exercises

Exercise 5.6. Let $x \in X$ and $s = f(x)$. Set

$$U = T_x X, \quad V = T_s S, \quad W = T_s Y, \quad T = Df : U \rightarrow V, \quad R = \text{range } T.$$

For every subspace $E \subset W$ we denote by $E^\perp \subset W^*$ its annihilator in W^* ,

$$E^\perp := \{w \in W^*; \langle w, e \rangle = 0, \forall e \in E\}.$$

We have

$$f \text{ transversal to } S \iff R + V = W \iff (R + V)^\perp = 0.$$

On the other hand,

$$(R + V)^\perp = R^\perp \cap V^\perp, \quad R^\perp = \ker T^*,$$

so that

$$\ker T^* \cap V^\perp = 0.$$

If u is a function on Y then $du_s \in W^*$. If $u|_S = 0$ we deduce $du_s \in V^\perp$. Then

$$f^*(du)_x = T^*(du|_s)$$

and thus

$$f^*(du)_x = 0 \iff du_s \in \ker T^* \cap V^\perp = 0.$$

- (b) Let $c = \text{codim } S$. Then S is defined near $s \in S$ by an equality

$$u^1 = \dots = u^c = 0, \quad du^i|_s \text{ linearly independent in } T_s^* S,$$

and $f^{-1}(S)$ is defined near $x \in f^{-1}$ by the equality

$$v^i = 0, \quad i = 1, \dots, c, \quad v^i - f^*u^i.$$

We have

$$\sum_i \lambda_i dv_x^i = 0, \quad \lambda^i \in \mathbb{R} \implies f^*(du)_x = 0, \quad u = \sum_i \lambda_i u^i,$$

and from part (a) we deduce $du_s = 0 \in T_s^*S$. Since du_s^i are linearly independent, we deduce $\lambda_i = 0$, and thus dv_x^i are linearly independent. From the implicit function theorem we deduce that $f^{-1}(S)$ is a submanifold of codimension c . \square

Exercise 5.7. Set

$$Z = \{(x, \lambda) \in X \times \Lambda; (\lambda, f_\lambda(x)) \in \tilde{S}\} = G^{-1}(\tilde{S}).$$

Denote by $\zeta : Z \rightarrow \Lambda$ the restriction to Z of the natural projection $X \times \Lambda \rightarrow \Lambda$ and let

$$Z_\lambda = \zeta^{-1}(\lambda) \cong \{x \in X; (x, \lambda) \in Z\} = f_\lambda^{-1}(S_\lambda).$$

Sard's theorem implies that there exists a negligible set $\Lambda_0 \subset \Lambda$ such that for every $\lambda \in \Lambda \setminus \Lambda_0$ either the fiber Z_λ is empty or for every $(x, \lambda) \in Z_\lambda$ the differential

$$\zeta_* : T_{(x, \lambda)}Z \rightarrow T_\lambda \Lambda$$

is surjective. If $Z_\lambda = \emptyset$, then f_λ is tautologically transversal to S_λ .

Let $(x_0, \lambda_0) \in Z$ such that $\zeta_* : T_{(x_0, \lambda_0)}Z \rightarrow T_{\lambda_0} \Lambda$ is onto. Set $(y_0, \lambda_0) = G(x_0, \lambda_0) \in \tilde{S}$,

$$\begin{aligned} \dot{X} &:= T_{x_0}X, & \dot{Y} &:= T_{y_0}Y, & \dot{\Lambda} &:= T_{\lambda_0}\Lambda, \\ \dot{S} &:= T_{(y_0, \lambda_0)}\tilde{S}, & \dot{S}_0 &:= T_{y_0}S_{\lambda_0}, & \dot{Z} &:= T_{(x_0, \lambda_0)}Z. \end{aligned}$$

Decompose the differential F_* of F at (x_0, λ_0) in partial differentials

$$A = D_\lambda F : \dot{\Lambda} \rightarrow \dot{Y}, \quad B = D_x F = D_x f_{\lambda_0} : \dot{X} \rightarrow \dot{Y}.$$

The transversality assumption on G implies that

$$\dot{Y} \oplus \dot{\Lambda} = \dot{S} + G_*(\dot{X} \oplus \dot{\Lambda}). \quad (5.4)$$

Observe that

$$\dot{S}_0 = \dot{S} \cap (\dot{Y} \oplus 0).$$

Moreover, our choice of (x_0, λ_0) implies that $\zeta_* : \dot{Z} \subset \dot{X} \oplus \dot{\Lambda} \rightarrow \dot{\Lambda}$ is onto. We have to prove that

$$\dot{Y} = B(\dot{X}) + \dot{S}_0.$$

Let $\dot{y}_0 \in \dot{Y}$. We want to show that $\dot{y}_0 \in B(\dot{X}) + \dot{S}_0$. From (5.4) we deduce

$$\exists(\dot{x}_0, \dot{\lambda}_0) \in \dot{X} \oplus \dot{\Lambda}, \quad (\dot{y}_1, \dot{\lambda}_1) \in \dot{S}$$

such that

$$(\dot{y}_0, 0) = G_*(\dot{x}_0, \dot{\lambda}_0) + (\dot{y}_1, \dot{\lambda}_1) \iff (\dot{y}_0, 0) = (A\dot{\lambda}_0 + B\dot{x}_0, \dot{\lambda}_0) + (\dot{y}_1, \dot{\lambda}_1).$$

Thus $\dot{\lambda}_1 = -\dot{\lambda}_0$ and $(\dot{y}_1, -\dot{\lambda}_0) \in \dot{S}$ and

$$(\dot{x}_1, \dot{\lambda}_0) = (A\dot{\lambda}_0 + B\dot{x}_0, \dot{\lambda}_0) + \underbrace{(\dot{y}_1, -\dot{\lambda}_0)}_{\in \dot{S}}.$$

On the other hand, $\dot{\lambda}_0$ lies in the image projection $\zeta_* : \dot{Z} \rightarrow \dot{\Lambda}$, so that $\exists \dot{x}_1 \in \dot{X}$ such that $(\dot{x}_1, \dot{\lambda}_0) \in \dot{Z}$. Since $G_*\dot{Z} \subset \dot{S}$, we deduce

$$G_*(\dot{x}_1, \dot{\lambda}_0) \in \dot{S} \iff (A\dot{\lambda}_0 + B\dot{x}_1, \dot{\lambda}_0) \in \dot{S}.$$

Now we can write

$$\begin{aligned} (\dot{y}_0, 0) &= G_*\left((\dot{x}_0, \dot{\lambda}_0) - (\dot{x}_1, \dot{\lambda}_0)\right) + \underbrace{G_*(\dot{x}_1, \dot{\lambda}_0)}_{\in \dot{S}} + \underbrace{(\dot{y}_1, -\dot{\lambda}_0)}_{\in \dot{S}} \\ &\iff (\dot{y}_0, 0) = (B(\dot{x}_0 - \dot{x}_1), 0) + \underbrace{(B\dot{x}_1 + A\dot{\lambda}_0 + \dot{y}_1, 0)}_{\in \dot{S}_0}. \end{aligned}$$

This proves that $\dot{y}_0 \in B(\dot{X}) + \dot{S}_0$. \square

Exercise 5.9. Let $\mathbf{v} \in S^n$ and suppose $x \in M$ is a critical point of $\ell_{\mathbf{v}}$. Modulo a translation we can assume that $x = 0$. We can then find an orthonormal basis $(e_1, \dots, e_n, e_{n+1})$ with coordinate functions (x^1, \dots, x^{n+1}) such that $\mathbf{v} = e_{n+1}$. From the implicit function theorem we deduce that near 0 the hypersurface M can be expressed as the graph of a smooth function

$$x^{n+1} = f(x), \quad x = (x^1, \dots, x^n), \quad df(0) = 0.$$

Thus (x^1, \dots, x^n) define local coordinates on M near 0. The function $\ell_{\mathbf{v}}$ on M then coincides with the coordinate function $x^{n+1} = f(x)$.

Near $e_{n+1} \in S^n = \{(y^1, \dots, y^{n+1}) \in \mathbb{R}^{n+1}; \sum_i |y^i|^2 = 1\}$ we can choose $y = (y^1, \dots, y^n)$ as local coordinates. Observe that

$$\mathcal{N}_M(x) = \frac{1}{(1 + |\nabla f|^2)^{1/2}}(e_{n+1} - \nabla f).$$

In the coordinates x on M and y on S^n the Gauss map $\mathcal{N}_M : M \rightarrow S^n$ is expressed by

$$\mathcal{N}_M(x) = -\frac{1}{(1 + |\nabla f|^2)^{1/2}}\nabla f.$$

For simplicity, we set $g = -\nabla f$ and we deduce that

$$D_0\mathcal{N}_M : T_0M \rightarrow T_{e_{n+1}}S^{n+1}$$

is equal to

$$D\frac{1}{(1+|g|^2)^{1/2}}g|_{x=0} = d\left(\frac{1}{(1+|g|^2)^{1/2}}\right)g|_{x=0} + \frac{1}{(1+|g|^2)^{1/2}}Dg|_{x=0}.$$

Since $g(0) = 0$ and $Dg|_{x=0} = -H_{f,0}$, we conclude that

$$D_0\mathcal{N}_M = D\frac{1}{(1+|g|^2)^{1/2}}g|_{x=0} = -\frac{1}{(1+|g|^2)^{1/2}}H_{g,0}.$$

Hence $0 \in M$ is a regular point of \mathcal{N}_M if and only if $\det H_{h,0} \neq 0$, i.e., 0 is a nondegenerate critical point of f . \square

Remark 5.39. The differential of the Gauss map is called the *second fundamental form* of the hypersurface. The above computation shows that it is a symmetric operator. If we denote by $\lambda_1, \dots, \lambda_n$ the eigenvalues of this differential at a point $x \in M$, then the celebrated *Theorema Egregium* of Gauss states that the symmetric combination $\sum_{i \neq j} \lambda_i \lambda_j$ is the *scalar curvature* of M at x with respect to the metric induced by the Euclidean metric in \mathbb{R}^{n+1} . In particular, this shows that the local minima and maxima of $\ell_{\mathbf{v}}$ are attained at points where the scalar curvature is positive.

If Σ is a *compact* Riemann surface embedded in \mathbb{R}^3 , then $\ell_{\mathbf{v}}$ has global minima and maxima and thus there exist points in Σ where the scalar curvature is positive. Hence, a compact Riemann surface equipped with a hyperbolic metric (i.e., scalar curvature = -2) cannot be *isometrically* embedded in \mathbb{R}^3 . \square

Exercise 5.10. To prove the equality

$$m(u) = \frac{1}{4\pi} \int_U \mathcal{N}_{\Sigma}^* dV_{S^2}$$

use Exercise 5.9. The second equality follows from the classical identity, [Ni, Example 4.2.14], [Str, Sections 4-8, p. 156]

$$\mathcal{N}_{\Sigma}^* dV_{S^2} = \frac{s}{2} dV_g.$$

\square

Exercise 5.11. See [BK, Section 4]. \square

Exercise 5.14. (a) Suppose f is a Morse function on M . Denote by $P_f(t)$ its Morse polynomial. Then the number of critical points of f is $P_f(1)$. The Morse inequalities show that there exists $Q \in \mathbb{Z}[t]$ with nonnegative coefficients such that

$$P_f(t) = P_M(t) + (1+t)Q(t). \quad (\dagger)$$

Since M is odd dimensional and orientable, we have $\chi(M) = 0$ and we deduce

$$P_f(-1) = P_M(-1) = \chi(M) = 0.$$

Finally, note that

$$P_f(1) \equiv P_f(-1) \pmod{2} \implies P_f(1) \in 2\mathbb{Z}.$$

(b) For every $n \geq 1$ denote by S^n the round sphere

$$S^n = \left\{ (x^0, \dots, x^n) \in \mathbb{R}^{n+1}; \sum_i |x^i|^2 = 1 \right\}.$$

The function $h_n : S^n \rightarrow \mathbb{R}$, $h_n(x^0, \dots, x^n) = x^n$ is a perfect Morse function on S^n because its only critical points are the north and south poles. Now consider the function

$$h_{n,m} : S^n \times S^m \rightarrow \mathbb{R}, \quad h_{n,m}(x, y) = h_n(x) + h_m(y).$$

One can check easily that

$$P_{h_{n,m}}(t) = P_{h_n}(t) \cdot P_{h_m}(t) = P_{S^n}(t) \cdot P_{S^m}(t) = P_{S^n \times S^m}(t).$$

(c) Suppose $H_\bullet(M, \mathbb{Z}) \cong H_\bullet(S^3, \mathbb{Z})$ and f has fewer than 6 critical points, i.e., $P_f(1) < 6$. Since $P_f(1)$ is an even number, we deduce $P_f(1) = 2, 4$. On the other hand, the fundamental group of M is nontrivial and non Abelian. This means that any presentation of $\pi_1(M)$ has to have at least two generators. In particular, any CW decomposition of M must have at least two cells of dimension 1. Hence the coefficient of t in $P_f(t)$ must be at least two. Since f must have a maximum and a minimum, we deduce that the coefficients of t^0 and t^3 in P_f are strictly positive. Now using $P_f(t) < 6$ we conclude that

$$P_f(t) = 1 + 2t + t^3.$$

However, in this case $P_f(-1) = 1 - 3 \neq \chi(M)$. □

Exercise 5.16. The range of ℓ_u is a compact interval $[m, M]$, where

$$m = \min_K \ell_u, \quad M = \max_K \ell_u, \quad m < M.$$

Observe that for every $t \in (m, M)$ the intersection of the hyperplane

$$\{(u, x) = t\}$$

with the knot K consists of precisely two points, $B_0(t), B_1(t)$ (see Figure 5.2). The construction of the unknotting isotopy uses the following elementary fact.

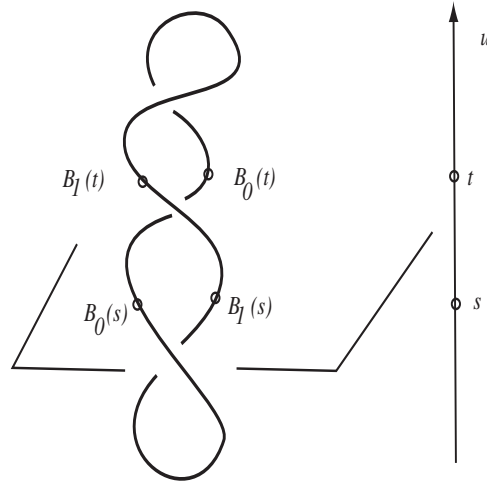

Fig. 5.2. Unwinding a garden hose.

Given a pair of distinct points $(A_0, A_1) \in \mathbb{R}^2 \times \mathbb{R}^2$, and any pair of continuous functions

$$B_0, B_1 : [0, 1] \rightarrow \mathbb{R}^2$$

such that

$$B_0(0) = A_0, \quad B_1(0) = A_1, \quad B_0(t) \neq B_1(t), \quad \forall t \in [0, 1],$$

there exist continuous functions

$$\lambda : [0, 1] \rightarrow (0, \infty), \quad S : [0, 1] \rightarrow SO(2)$$

such that $\lambda(0) = 1, S_0 = \mathbb{1}$ and for every $t \in [0, 1]$ the affine map

$$T_t : \mathbb{R}^2 \rightarrow \mathbb{R}^2, \quad T_t(x) = B_0(t) + \lambda(t)S_t(x - A_0)$$

maps A_0 to $B_0(t)$ and A_1 to $B_1(t)$.

To prove this elementary fact use the lifting properties of the universal cover of $SO(2) \cong S^1$. □

Exercise 5.17. Consider the S -shaped embedding in \mathbb{R}^3 of the two sphere depicted in Figure 5.3. The height function $h(x, y, z) = z$ induces a Morse function on S^2 with six critical points. This height function has all the required properties. □

Exercise 5.18. We have

$$\nabla f = (1 - z^2) \frac{\partial}{\partial z},$$

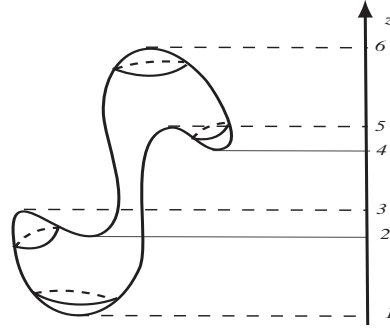

Fig. 5.3. An embedding of S^2 in \mathbb{R}^3 .

and therefore the gradient flow equation (5.1) has the form

$$\dot{z} = (z^2 - 1), \quad \dot{\theta} = 0, \quad z(0) = z_0, \quad \theta(0) = \theta_0, \quad z \in [-1, 1].$$

This equation is separable and we deduce

$$\frac{dz}{z^2 - 1} = dt \iff \left(\frac{1}{z + 1} + \frac{1}{1 - z} \right) dz = -2dt.$$

Integrating from 0 to t we deduce

$$\log\left(\frac{1+z}{1-z}\right) = \log\left(e^{-2t} \frac{1+z_0}{1-z_0}\right) \implies \frac{1+z}{1-z} = e^{-2t} \frac{1+z_0}{1-z_0}.$$

We conclude that

$$z = \phi_t(z_0) := \frac{C(z_0) - e^{2t}}{C(z_0) + e^{2t}}, \quad C(z) := \frac{1+z}{1-z}.$$

Hence

$$\Phi_t(z, \theta) = (\phi_t(z), \theta).$$

Now

$$\omega_g = d\theta \wedge dz \implies \lambda_t(z) = \frac{d}{dz} \phi_t(z).$$

Using the equalities

$$\phi_t(z) = 1 - \frac{2e^{2t}}{C(z) + e^{2t}}, \quad C(z) = \frac{2}{1-z} - 1$$

we deduce

$$\lambda_t = \frac{2e^{2t}}{(z-1)^2(C(z) + e^{2t})^2},$$

which shows that as $t \rightarrow \infty$ λ_t converges to 0 uniformly on the compacts of $S^2 \setminus \{N\} = S^2 \setminus \{z = 1\}$.

Let $u \in C^\infty(S^2)$ and set $u_0 = u(N)$. Then

$$\left(\int_{S^2} u \omega_t \right) - u_0 = \int_{S^2} (u - u_0) \omega_t$$

Set $v = u - u_0$. Fix a tiny disk D_ε of radius $\varepsilon > 0$ centered at the north pole. We then have

$$\left| \int_{S^2} v \omega_t \right| \leq \underbrace{\left| \int_{D_\varepsilon} v \lambda_t \omega_g \right|}_{A(t, \varepsilon)} + \underbrace{\left| \int_{S^2 \setminus D_\varepsilon} v \lambda_t \omega_g \right|}_{B(t, \varepsilon)}.$$

Then

$$A(t, \varepsilon) \leq \left(\sup_{D_\varepsilon} |v| \right) \cdot \int_{D_\varepsilon} \omega_t \leq \left(\sup_{D_\varepsilon} |v| \right),$$

while

$$B(t, \varepsilon) \leq \text{area}(S^2) \cdot \sup_{S^2} |v| \cdot \sup_{S^2 \setminus D_\varepsilon} |\lambda_t| \xrightarrow{t \rightarrow \infty} 0.$$

This proves

$$0 \leq \liminf_{t \rightarrow \infty} \left| \int_{S^2} v \omega_t \right| \leq \limsup_{t \rightarrow \infty} \left| \int_{S^2} v \omega_t \right| \leq \left(\sup_{D_\varepsilon} |v| \right), \quad \forall \varepsilon > 0.$$

Since v is continuous at the north pole and at that point $v = 0$, we deduce

$$\lim_{\varepsilon \searrow 0} \left(\sup_{D_\varepsilon} |v| \right) = 0.$$

Hence

$$\lim_{t \rightarrow \infty} \int_{S^2} v \omega_t = 0.$$

□

Exercise 5.19 Let $n := \dim V$. Then

$$\dim \text{End}_-(V) = \binom{n}{2}, \quad \dim \text{End}_+(V) = \binom{n+1}{2}$$

and thus

$$\dim \text{End}_-(V) + \dim \text{End}_+(V) = n^2 = \dim \text{End}(V).$$

If $S \in \text{End}_-(V)$ and $T \in \text{End}_+(V)$, then

$$\langle S, T \rangle = \text{tr } ST^* = \text{tr } ST = -\text{tr } S^*T = -\text{tr } TS^* = -\langle T, S \rangle$$

so that

$$\langle S, T \rangle = 0.$$

This completes part (a).

(b) Observe that $T_1SO(V) = \text{End}_-(V)$. Fix an orthonormal basis

$$\{ e_i; i = 1, 2, \dots, n \}$$

of V consisting of eigenvectors of A ,

$$Ae_i = \lambda_i e_i.$$

We assume $\lambda_i < \lambda_j$ if $i < j$.

If $T \in SO(V)$ is a critical point of f_A , then for every $X \in \text{End}_-(V)$ we have

$$\left. \frac{d}{dt} \right|_{t=0} f_A(Te^{tX}) = 0 \iff \text{tr} ATX = 0, \quad \forall X \in \text{End}_-(V).$$

From part (a) we deduce that T is a critical point of f_A if and only if AT is a symmetric operator, i.e.,

$$AT = T^*A = T^{-1}A \iff TAT = A.$$

If T is described in the basis (e_i) by the matrix (t_j^i) ,

$$Te_j = \sum_i t_j^i e_i, \quad \forall j,$$

then the symmetry of AT translates into the collection of equalities

$$\lambda_i t_j^i = \lambda_j t_i^j, \quad \forall i, j.$$

We want to prove that these equalities imply that $t_j^i = 0, \forall i \neq j$, i.e., T is diagonal.

Indeed, since T is orthogonal we deduce that the sum of the squares of elements in any row, or in any column is 1. Hence

$$1 = \sum_j (t_j^i)^2 = \sum_j \left(\frac{\lambda_j}{\lambda_i} \right)^2 (t_i^j)^2, \quad \forall i.$$

We let $i = 1$ in the above equality, and we conclude that

$$1 = \sum_{j=1}^n (t_1^j)^2 = \sum_{j=1}^n \left(\frac{\lambda_j}{\lambda_1} \right)^2 (t_1^j)^2$$

($\lambda_j > \lambda_1, \forall j \neq 1$)

$$\geq \sum_{j=1}^n (t_1^j)^2 = 1.$$

The equality can hold if and only if $t_1^j = t_j^1 = 0, \forall j \neq 1$. We have thus shown that the off-diagonal elements in the first row and the first column of T are zero. We now proceed inductively.

We assume that the off-diagonal elements in the first k columns and rows of T are zero, and we will prove that this is also the case for the $(k+1)$ -th row and column. We have

$$\begin{aligned} 1 &= \sum_{j=1}^n (t_{k+1}^j)^2 = \sum_{j=1}^n \left(\frac{\lambda_j}{\lambda_{k+1}} \right)^2 (t_{k+1}^j)^2 \\ &= \sum_{j>k} \left(\frac{\lambda_j}{\lambda_{k+1}} \right)^2 (t_{k+1}^j)^2 \geq \sum_{j>k} (t_{k+1}^j)^2 = \sum_{j=1}^n (t_{k+1}^j)^2 = 1. \end{aligned}$$

Since $\lambda_j > \lambda_{k+1}$ if $j > k+1$, we deduce from the above string of (in)equalities that

$$t_{k+1}^j = t_j^{k+1} = 0, \quad \forall j \neq k+1.$$

This shows that the critical points of f_A are the diagonal matrices

$$\text{Diag}(\epsilon_1, \dots, \epsilon_n), \quad \epsilon_j = \pm 1, \quad \prod_{j=1}^n \epsilon_j = 1.$$

Their number is

$$\binom{n}{0} + \binom{n}{2} + \binom{n}{4} + \dots = 2^{n-1}.$$

Fix a vector $\epsilon \in \{-1, 1\}^n$ with the above properties and denote by T_ϵ the corresponding critical point of f_A . We want to show that T_ϵ is a nondegenerate critical point and then determine its Morse index, $\lambda(\epsilon)$.

A neighborhood of T_ϵ in $SO(V)$ can be identified with a neighborhood of $0 \in \text{End}_-(V)$ via the exponential map

$$\text{End}_-(V) \ni X \mapsto T_\epsilon \exp(X) \in SO(V).$$

Using the basis (e_i) we can identify $X \in SO(V)$ with its matrix (x_j^i) . Since $x_j^i = -x_i^j$ we can use the collection

$$\{x_j^i; 1 \leq j < i \leq n\}$$

as local coordinates near T_ϵ . We have

$$\exp(X) = \mathbb{1}_V + X + \frac{1}{2}X^2 + O(3),$$

where $O(r)$ denotes terms of size less than some constant multiple of $\|X\|^r$ as $\|X\| \rightarrow 0$. Then

$$f_A(T_\epsilon \exp(X)) = f_A(T_\epsilon) - \frac{1}{2} \text{tr}(AT_\epsilon X^2) + O(3).$$

Thus the Hessian of f_A at T_ϵ is given by the quadratic form

$$\mathcal{H}_\epsilon(X) = -\frac{1}{2} \operatorname{tr}(AT_\epsilon X^2) = -\frac{1}{2} \sum_{j=1}^n \epsilon_j \lambda_j \sum_{k=1}^n x_k^j x_j^k$$

$$(x_k^j = -x_j^k)$$

$$= \frac{1}{2} \sum_{j,k=1}^n \epsilon_j \lambda_j (x_k^j)^2 = \frac{1}{2} \sum_{1 \leq j < k \leq n} (\epsilon_j \lambda_j + \epsilon_k \lambda_k) (x_k^j)^2.$$

The last equalities show that \mathcal{H}_ϵ diagonalizes in the coordinates (x_k^j) and its eigenvalues are

$$\mu_{jk} = \mu_{jk}(\epsilon) := (\epsilon_j \lambda_j + \epsilon_k \lambda_k), \quad 1 \leq k < j \leq n.$$

None of these eigenvalues is zero, since $0 < \lambda_k < \lambda_j$ if $k < j$. Moreover,

$$\mu_{jk}(\epsilon) < 0 \iff \underbrace{\epsilon_j, \epsilon_k < 0}_{\text{Type 1}} \quad \text{or} \quad \underbrace{\epsilon_j < 0 < \epsilon_k}_{\text{Type 2}}.$$

For $i = 1, 2$ we denote by $\lambda_i(\epsilon)$ the number of Type i negative eigenvalues $\mu_{jk}(\epsilon)$ so that

$$\lambda(\epsilon) = \lambda_1(\epsilon) + \lambda_2(\epsilon).$$

We set

$$Z_\epsilon := \{j; \epsilon_j < 0\}, \quad \nu(\epsilon) := \#Z_\epsilon.$$

Observe that $\nu(\epsilon)$ is an even, nonnegative integer. The number of Type 1 negative eigenvalues is then

$$\lambda_1(\epsilon) = \sum_{j \in Z_\epsilon} \#\{k \in Z_\epsilon; k < j\} = \binom{\nu(\epsilon)}{2}.$$

On the other hand, we have

$$\lambda_2(\epsilon) = \sum_{j \in Z_\epsilon} \#\{k \notin Z_\epsilon; k < j\}.$$

Hence

$$\lambda(\epsilon) = \lambda_1(\epsilon) + \lambda_2(\epsilon) = \sum_{j \in Z_\epsilon} \#\{k < j\} = \sum_{j \in Z_\epsilon} (j - 1) = \sum_{j \in Z_\epsilon} j - \nu(\epsilon).$$

(c) To find a compact description for the Morse polynomial of f_A we need to use a different kind of encoding. For every positive integer k we denote by $I_{k,n}$ the collection of strictly increasing maps

$$\{1, 2, \dots, k\} \rightarrow \{1, 2, \dots, n\}.$$

For $\varphi \in I_{k,n}$ we set

$$|\varphi| := \sum_{j=1}^k \varphi(j).$$

Define for uniformity

$$I_{0,n} := \{*\}, \quad |*| := 0.$$

Denote by P_n the Morse polynomial of $f_A : SO(V) \rightarrow \mathbb{R}$, $n = \dim V$. Then

$$P_n(t) = \sum_{k \text{ even}} t^{-k} \sum_{\varphi \in I_{k,n}} t^{|\varphi|}.$$

For every k , even or not, define

$$S_{k,n}(t) = \sum_{\varphi \in I_{k,n}} t^{|\varphi|},$$

and consider the Laurent polynomial in two variables

$$Q_n(t, z) = \sum_k z^{-k} S_{k,n}(t).$$

If we set

$$Q_n^\pm(t, z) = \frac{1}{2} (Q_n(t, z) \pm Q_n(t, -z)),$$

then

$$P_n(t) = Q_n^+(t, z = t).$$

For every k , even or not, an increasing map $\varphi \in I_{k,n}$ can be of two types.

- A.** $\varphi(k) < n \iff \varphi \in I_{k,n-1}$.
- B.** $\varphi(k) = n$, so that φ is completely determined by its restriction

$$\varphi|_{\{1, \dots, k-1\}}$$

which defines an element $\varphi' \in I_{k-1, n-1}$ satisfying

$$|\varphi'| = |\varphi| - n.$$

The sum $S_{k,n}(t)$ decomposes according to the two types

$$S_{k,n} = A_{k,n}(t) + B_{k,n}(t).$$

We have

$$A_{k,n}(t) = S_{k,n-1}(t), \quad B_{k,n}(t) = t^n S_{k-1, n-1}(t).$$

We multiply the above equalities by z^{-k} and we deduce

$$z^{-k} S_{k,n}(t) = z^{-k} S_{k,n-1} + z^{-k} t^n S_{k-1, n-1}.$$

If we sum over k we deduce

$$Q_n(t, z) = Q_{n-1}(t, z) + z^{-1}t^n Q_{n-1}(t, z) = (1 + z^{-1}t^n)Q_{n-1}(t, z).$$

We deduce that for every $n > 2$ we have

$$Q_n(t, z) = \left(\prod_{m=3}^n (1 + z^{-1}t^m) \right) Q_2(t, z).$$

On the other hand, we have

$$\begin{aligned} Q_2(t, z) &= S_{0,2}(t) + z^{-1}S_{1,2}(t) + z^{-2}S_{2,2}(t) = 1 + z^{-1}(t + t^2) + z^{-2}t^3 \\ &= (1 + z^{-1}t)(1 + z^{-1}t^2), \\ Q_2^+(t, z) &= 1 + z^{-2}t^3, \quad Q_2^+(t, z = t) = 1 + t. \end{aligned}$$

We deduce that

$$Q_n(t, z) = \prod_{m=1}^n (1 + z^{-1}t^m), \quad Q_n^+(t, z) = \frac{1}{2} \prod_{m=1}^n (1 + z^{-1}t^m) + \frac{1}{2} \prod_{m=1}^n (1 - z^{-1}t^m),$$

so that

$$P_n(t) = Q_n^+(t, z)|_{z=t} = \frac{1}{2} \prod_{m=1}^n (1 + t^{m-1}) + \frac{1}{2} \underbrace{\prod_{m=1}^n (1 - t^{m-1})}_{=0} = \prod_{k=1}^{n-1} (1 + t^k). \quad \square$$

Exercise 5.21 For a proof and much more we refer to [DV]. □

Exercise 5.22 Part (a) is immediate. Let $v = P_L v + P_{L^\perp} v = v_L + v_{L^\perp} \in V$ (see Figure 5.4). Then

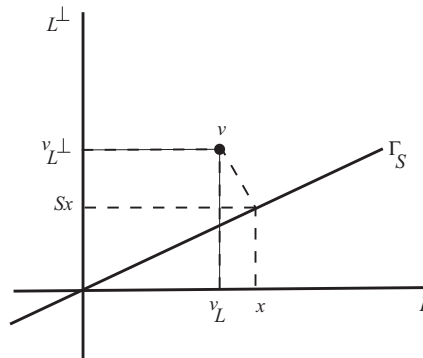

Fig. 5.4. Subspaces as graphs of linear operators.

$$\begin{aligned}
P_{\Gamma_S} v &= x + Sx, \quad x \in L \iff v - (x + Sx) \in \Gamma_S^\perp \\
&\iff \exists x \in L, \quad y \in L^\perp \quad \text{such that} \quad \begin{cases} x + S^*y = v_L, \\ Sx - y = v_{L^\perp}. \end{cases}
\end{aligned}$$

Consider the operator $\mathfrak{S} : L \oplus L^\perp \rightarrow L \oplus L^\perp$, which has the block decomposition

$$\mathfrak{S} = \begin{bmatrix} \mathbb{1}_L & S^* \\ S & -\mathbb{1}_{L^\perp} \end{bmatrix}.$$

Then the above linear system can be rewritten as

$$\mathfrak{S} \cdot \begin{bmatrix} x \\ y \end{bmatrix} = \begin{bmatrix} v_L \\ v_{L^\perp} \end{bmatrix}.$$

Now observe that

$$\mathfrak{S}^2 = \begin{bmatrix} \mathbb{1}_L + S^*S & 0 \\ 0 & \mathbb{1}_{L^\perp} + SS^* \end{bmatrix}.$$

Hence \mathfrak{S} is invertible and

$$\begin{aligned}
\mathfrak{S}^{-1} &= \begin{bmatrix} (\mathbb{1}_L + S^*S)^{-1} & 0 \\ 0 & (\mathbb{1}_{L^\perp} + SS^*)^{-1} \end{bmatrix} \cdot \mathfrak{S} \\
&= \begin{bmatrix} (\mathbb{1}_L + S^*S)^{-1} & (\mathbb{1}_L + S^*S)^{-1}S^* \\ (\mathbb{1}_{L^\perp} + SS^*)^{-1}S & -(\mathbb{1}_{L^\perp} + SS^*)^{-1} \end{bmatrix}.
\end{aligned}$$

We deduce

$$x = (\mathbb{1}_L + S^*S)^{-1}v_L + (\mathbb{1}_L + S^*S)^{-1}S^*v_{L^\perp}$$

and

$$P_{\Gamma_S} v = \begin{bmatrix} x \\ Sx \end{bmatrix}.$$

Hence P_{Γ_S} has the block decomposition

$$\begin{aligned}
P_{\Gamma_S} &= \begin{bmatrix} \mathbb{1}_L \\ S \end{bmatrix} \cdot [(\mathbb{1}_L + S^*S)^{-1} \quad (\mathbb{1}_L + S^*S)^{-1}S^*] \\
&= \begin{bmatrix} (\mathbb{1}_L + S^*S)^{-1} & (\mathbb{1}_L + S^*S)^{-1}S^* \\ S(\mathbb{1}_L + S^*S)^{-1} & S(\mathbb{1}_L + S^*S)^{-1}S^* \end{bmatrix}.
\end{aligned}$$

If we write $P_t := P_{\Gamma_{tS}}$, we deduce

$$P_t = \begin{bmatrix} (\mathbb{1}_L + t^2S^*S)^{-1} & t(\mathbb{1}_L + t^2S^*S)^{-1}S^* \\ tS(\mathbb{1}_L + t^2S^*S)^{-1} & t^2S(\mathbb{1}_L + t^2S^*S)^{-1}S^* \end{bmatrix}.$$

Hence

$$\frac{d}{dt}P_t|_{t=0} = \begin{bmatrix} 0 & S^* \\ S & 0 \end{bmatrix} = S^*P_{L^\perp} + SP_L. \quad \square$$

Exercise 5.23. Suppose $L \in G_k(V)$. With respect to the decomposition $V = L \oplus L^\perp$ the operator A has the block decomposition

$$A = \begin{bmatrix} A_L & B^* \\ B & A_{L^\perp} \end{bmatrix},$$

$$B \in \text{Hom}(L, L^\perp), A_L \in \text{Hom}(L, L), A_{L^\perp} \in \text{Hom}(L^\perp, L^\perp).$$

Suppose we are given $S \in \text{Hom}(L, L^\perp) \cong T_L G_k(V)$. Then

$$\begin{aligned} \left. \frac{d}{dt} \right|_{t=0} h_A(\Gamma_{tS}) &= - \left. \frac{d}{dt} \right|_{t=0} \mathbf{Re} \text{tr}(A P_{\Gamma_{tS}}) = - \mathbf{Re} \text{tr} \left(A \left. \frac{d}{dt} \right|_{t=0} P_{\Gamma_{tS}} \right) \\ &= - \mathbf{Re} \text{tr}(B^* S + B S^*) = -2 \mathbf{Re} \text{tr}(B S^*). \end{aligned}$$

We see that L is a critical point of h_A if and only if

$$\mathbf{Re} \text{tr}(B S^*) = 0, \quad \forall S \in \text{Hom}(L, L^\perp) \iff B = 0.$$

Hence L is a critical point of h_A if and only if A has a diagonal block decomposition with respect to L ,

$$A = \begin{bmatrix} A_L & 0 \\ 0 & A_{L^\perp} \end{bmatrix}.$$

This happens if and only if $AL \subset L$. This proves part (a).

Choose a unitary frame $(e_i)_{1 \leq i \leq n}$ of V consisting of eigenvectors of A ,

$$Ae_i = a_i e_i, \quad a_i \in \mathbb{R}, \quad i < j \implies a_i < a_j.$$

Then $L \subset V$ is an invariant subspace of V if and only if there exists a cardinality k subset $I = I_L \subset \{1, \dots, n\}$ such that

$$L = V_I = \text{span}_{\mathbb{C}}\{e_i; \quad i \in I_L\}.$$

Denote by $J = J_L$ the complement of I and by V_J the subspace spanned by $\{e_j; \quad j \in J\}$. Any $S \in \text{Hom}(V_I, V_J)$ is described by a matrix

$$S = (s_{ij})_{i \in I, j \in J}.$$

Then

$$\begin{aligned} h_A(\Gamma_S) &= - \mathbf{Re} \text{tr} \begin{bmatrix} A_L(\mathbb{1}_L + S^* S)^{-1} & A_L(\mathbb{1}_L + S^* S)^{-1} S^* \\ A_{L^\perp} S(\mathbb{1}_L + S^* S)^{-1} & A_{L^\perp} S(\mathbb{1}_L + S^* S)^{-1} S^* \end{bmatrix} \\ &= - \mathbf{Re} \text{tr} A_L(\mathbb{1}_L + S^* S)^{-1} - \mathbf{Re} \text{tr} A_{L^\perp} S(\mathbb{1}_L + S^* S)^{-1} S^*. \end{aligned}$$

If we denote by Q_L the Hessian of h_A at L then from the Taylor expansions ($\|S\| \ll 1$)

$$\begin{aligned} A_L(\mathbb{1}_L + S^* S)^{-1} &= A_L - A_L S^* S + \text{higher order terms}, \\ A_{L^\perp} S(\mathbb{1}_L + S^* S)^{-1} S^* &= A_{L^\perp} S S^* + \text{higher order terms}, \end{aligned}$$

we deduce

$$Q_L(S, S) = \mathbf{Re} \operatorname{tr} A_L S^* S - \mathbf{Re} \operatorname{tr} A_{L^\perp} S S^*, \quad \forall S \in \operatorname{Hom}(L, L^\perp) = T_L G_k(V).$$

Using the matrix description $S = (s_{ij})$ of S we deduce

$$Q_L(S, S) = \sum_{i \in I} \lambda_i \sum_{j \in J} |s_{ij}|^2 - \sum_{j \in J} \lambda_j \sum_{i \in I} |s_{ij}|^2 = \sum_{(i,j) \in I \times J} (\lambda_i - \lambda_j) |s_{ij}|^2.$$

This shows that the Hessian of h_A at L is nondegenerate and we denote by $\lambda(A, L)$ its index. It is an even integer because the coordinates s_{ij} are complex. Moreover,

$$\lambda(A, L) = 2\mu(I_L) = 2\#\{(i, j) \in I_L \times J_L; i < j\}.$$

Setting

$$I = I_L = \{i_1, \dots, i_k\}, \quad J = J_L$$

we deduce

$$\begin{aligned} \mu(I) &= \sum_{j \in J} \#\{i \in I; i < j\} \\ &= 0 \cdot (i_1 - 1) + \dots + (k-1) \cdot (i_k - i_{k-1} - 1) + k(n - i_k) \\ &= 1 \cdot (i_2 - i_1) + \dots + (k-1)(i_k - i_{k-1}) + k(n - i_k) - \sum_{i=1}^{k-1} i \\ &= -\sum_{i \in I} i + nk - \frac{k(k-1)}{2} = \sum_{i \in I} (n - i) - \frac{k(k-1)}{2} \\ &= \sum_{\ell=1}^k (n - i_\ell - (k - \ell)). \end{aligned}$$

Define

$$m_\ell := n - i_\ell - (k - \ell) = (n - k) - (i_\ell - \ell)$$

so that

$$\mu_I = \sum_{\ell=1}^k m_\ell. \quad (5.5)$$

Since

$$0 \leq (i_1 - 1) \leq (i_2 - 2) \leq \dots \leq (i_k - k) \leq (n - k)$$

we deduce

$$n - k \geq m_1 \geq \dots \geq m_k \geq 0.$$

Given a collection (m_1, \dots, m_k) with the above properties we can recover I by setting

$$i_\ell = (n - k) + \ell - m_\ell.$$

The Morse numbers of h_A are

$$M_{k,n}(\lambda) = \#\{L; \lambda(A, L) = \lambda\} = \#\{I; 2\#\mu(I) = \lambda\}.$$

The Morse polynomial is

$$M_{k,n}(t) = \sum_{\lambda} M_{k,n}(\lambda)t^{\lambda} = \sum_{\lambda} M_{k,n}(2\lambda)t^{2\lambda}.$$

For every nonnegative integers (a, b, c) we denote by $P(a|b, c)$ the number of partitions of a as a sum of b nonnegative integers $\leq c$,

$$a = x_1 + \dots + x_b, \quad 0 \leq x_1 \leq \dots \leq x_b \leq c.$$

Let $P_{b,c}(t)$ denote the generating polynomial

$$P_{b,c}(t) := \sum_a P(a|b, c)t^a.$$

The equality (5.5) implies

$$M_{k,n}(2\lambda) = P_{k,n-k}(\lambda) \implies M_{k,n}(t) = P_{k,n-k}(t^2).$$

The polynomial $P_{k,n-k}(t)$ can be expressed as a rational function

$$P_{k,n-k}(t) = \frac{\prod_{a=1}^n (1 - t^a)}{\prod_{b=1}^k (1 - t^b) \cdot \prod_{c=1}^{n-k} (1 - t^c)}.$$

For a proof we refer to [Ni, Lemma 7.4.27]. □

Exercise 5.26. (a) Fix an almost complex structure on V tamed by ω and denote by $g(\bullet, \bullet)$ the associated metric

$$g(u, v) = \omega(u, Jv) \iff \omega(u, v) = g(Ju, v), \quad \forall u, v \in V.$$

Identify V and its dual using the metric g . Then for every subspace $L \subset V$, $L^\perp \subset V^*$ is identified with the orthogonal complement of L . Moreover,

$$I_\omega = -J.$$

Then

$$L^\omega \cong \{v \in V; g(Ju, x) = 0, \quad \forall x \in L\} = JL^\perp.$$

(b) L is isotropic if and only if $L \subset JL^\perp$, and thus

$$\dim L + \dim L^\omega = \dim V, \quad \dim L \subset \dim L^\omega.$$

Thus $\dim L \leq \frac{1}{2} \dim V$ with equality iff $\dim L = \dim L^\omega$, iff $L = L^\omega$.

(c) Since L_0 and L_1 are transversal, we have natural isomorphisms

$$L_0 \oplus L_1 \rightarrow L_0 + L_1 \rightarrow V.$$

A subspace $L \subset V$ of dimension $\dim L = \dim L_0 = \dim L_1$ is transversal to L_1 if and only if it is the graph of a linear operator

$$A : L_0 \rightarrow L_1.$$

Let $u_0, v_0 \in L_0$. Then $Au_0, Av_0 \in L_1$ and $u_0 + Av_0, v_0 + Au_0 \in L$, so that

$$\begin{aligned} 0 &= \omega(u_0 + Au_0, v_0 + Av_0) \\ &= \omega(u_0, v_0) + \omega(Au_0, Av_0) + \omega(Au_0, v_0) + \omega(u_0, Av_0) \\ &= -\omega(v_0, Au_0) + \omega(u_0, Av_0) = Q(u_0, v_0) - Q(v_0, u_0). \end{aligned}$$

Let $u_0 \in L_0$. Then

$$\begin{aligned} Q(u_0, u) = 0, \quad \forall u \in L_0 &\iff \omega(u_1, u) = 0, \quad \forall u \in L_0, \quad (u_1 = Au_0) \\ &\iff \omega(u_1, v) = 0, \quad \forall v \in V \iff u_1 = 0. \end{aligned}$$

Thus Q is nondegenerate iff $\ker A = 0$ iff L is transversal to L_0 as well.

(b) Since this statement is coordinate independent, it suffices to prove it for a special choice of coordinates. Thus we can assume

$$M = \mathbb{R}^n, \quad E = \mathbb{R}^n \times M = \mathbb{R}^n \times \mathbb{R}^n, \quad x = 0 \in \mathbb{R}^n.$$

The coordinates on $\mathbb{R}^n \times \mathbb{R}^n$ are (ξ_i, x^j) . Then

$$L_0 = 0 \times \mathbb{R}_x^n, \quad L_1 = \mathbb{R}_\xi^n \times 0.$$

Then L is the graph of the linear operator

$$0 \times \mathbb{R}_x^n \rightarrow \mathbb{R}_\xi^n \times 0$$

given by the differential at $x = 0$ of the map $\mathbb{R}^n \ni x \mapsto \xi = df(x) \in \mathbb{R}^n$. This is precisely the Hessian of f at 0. Thus if the Hessian is given by the symmetric matrix (H_{ij}) , then

$$A\partial_{x^j} = \sum_i H_{ij} \partial_{\xi_i} \quad \text{and} \quad \omega(\partial_{x^i}, A\partial_{x^j}) = H_{ij}.$$

□

Exercise 5.27. (a) and (c) We have a tautological diffeomorphism

$$\gamma : M \rightarrow \Gamma_{df}, \quad x \mapsto (df(x), x).$$

Then

$$\gamma^*\theta = df, \quad \gamma^*\omega = -\gamma^*(d\theta) = -d\gamma^*\theta = -d(df) = 0.$$

This also implies part (c), since $\gamma^*d\theta$ is the differential of f .

(d) We need a few differential-geometric facts.

A. Suppose M is a smooth manifold and $\alpha_t, t \in \mathbb{R}$, is a smooth one parameter family (path) of differential forms of the same degree k . Denote by $\dot{\alpha}_t$ the path of differential forms defined by

$$\dot{\alpha}_t(x) = \lim_{h \rightarrow 0} \frac{1}{h} (\alpha_{t+h}(x) - \alpha_t(x)) \in \Lambda^k T_x^* M, \quad \forall x \in M, \quad t \in \mathbb{R}.$$

Construct the cylinder $\hat{M} = \mathbb{R} \times M$ and denote by $i_t : M \rightarrow \hat{M}$ the inclusion

$$M \hookrightarrow \mathbb{R} \times M, \quad x \mapsto (t, x).$$

The *suspension* of the family α_t is the k -form $\hat{\alpha}$ on \hat{M} uniquely determined by the conditions

$$\partial_t \lrcorner \hat{\alpha} = 0, \quad i_t^* \hat{\alpha} = \alpha_t.$$

We then have the equality

$$\dot{\alpha}_t = i_t^* L_{\partial_t} \hat{\alpha}.$$

Indeed, if we denote by d the exterior derivative on M and by \hat{d} the exterior derivative on \hat{M} , then $\hat{d} = dt \wedge \partial_t + d$, and

$$L_{\partial_t} \hat{\alpha} = \hat{d}(\partial_t \lrcorner \hat{\alpha}) + \partial_t \lrcorner (\hat{d}\hat{\alpha}) = \hat{\alpha}.$$

B. Suppose $\Phi : N_0 \rightarrow N_1$ is a *diffeomorphism* between two smooth manifolds, $\alpha \in \Omega^k(N_1)$, $X \in \text{Vect}(M)$. Then

$$L_X \Phi^* \alpha = \Phi^* (L_{\Phi_* X} \alpha).$$

Indeed, this a fancy way of rephrasing the coordinate independence of the Lie derivative. Equivalently, if $\beta \in \Omega^k(M)$ and we define the pushforward

$$\Phi_* \beta := (\Phi^{-1})^* \beta = (\Phi^*)^{-1} \beta,$$

then we have

$$\Phi_* (L_X \beta) = L_{\Phi_* X} \Phi_* \beta.$$

C. Suppose Φ_t is a one parameter family of diffeomorphisms of M . This determines a *time* dependent vector field on M

$$X_t(x) = \frac{d}{dh} \Big|_{h=0} \Phi_{t+h}(x), \quad \forall t \in \mathbb{R}, \quad x \in M.$$

We obtain a diffeomorphism

$$\hat{\Phi} : \hat{M} \rightarrow \hat{M}, \quad (t, x) \mapsto (t, \Phi_t(x)).$$

Observe that

$$\hat{\Phi}_*(\partial_t) = \hat{X} = \partial_t + X_t \in \text{Vect}(\hat{M}).$$

Suppose α is a k -form on M . We denote by α_t the path of forms $\alpha_t := \Phi_t^*(M)$. If we denote by $\pi : \hat{M} \rightarrow M$ the natural projection, then we have the equality

$$\hat{\alpha} = \hat{\Phi}^* \pi^* \alpha.$$

From **A** we deduce

$$\dot{\alpha}_t := i_t^* L_{\partial_t} \hat{\alpha}.$$

From **B** we deduce

$$\hat{\Phi}_*(L_{\partial_t} \hat{\alpha}) = L_{\Phi_* \partial_t} (\hat{\Phi}_* \hat{\alpha}) = L_{\hat{X}} \pi^* \alpha,$$

so that

$$L_{\partial_t} \hat{\alpha} = \hat{\Phi}^*(L_{\hat{X}} \pi^* \alpha) \implies \dot{\alpha}_t = \Phi_t^*(L_{\hat{X}} \pi^* \alpha).$$

Now observe that

$$L_{\hat{X}} \pi^* \alpha = L_{\partial_t} \pi^* \alpha + L_{X_t} \pi^* \alpha = L_{X_t} \pi^* \alpha.$$

Hence

$$\dot{\alpha}_t = \Phi_t^* L_{X_t} \alpha.$$

Suppose $X_t \lrcorner d\alpha = d\gamma_t, \forall t$. Then

$$L_{X_t} \alpha = X_t \lrcorner d\alpha + dX_t \lrcorner \alpha = d(\underbrace{\gamma_t + X_t \lrcorner \alpha}_{\varphi_t}),$$

so that

$$\dot{\alpha}_t = d \underbrace{\Phi_t^*(\gamma_t + X_t \lrcorner \alpha)}_{\varphi_t} \implies \alpha_t - \alpha_0 = d \int_0^t \varphi_s ds.$$

This shows that if $X_t \lrcorner d\alpha$ is exact on M for every t , then for every submanifold $L \subset M$ the restriction $\alpha_t|_L$ is exact for every $t > 0$, provided $\alpha_0|_L$ is exact. \square

Exercise 5.31. (a) The Fubini–Study form is clearly closed and invariant with respect to the tautological action of $U(n+1)$ on $\mathbb{C}\mathbb{P}^n$. Since the action of $U(n+1)$ is transitive, it suffices to show that ω defines a symplectic pairing on the tangent space of one point in $\mathbb{C}\mathbb{P}^n$. By direct computation (see a sample in part (b)) one can show that at the point $[1, 0, 0, \dots, 0]$ and in the affine coordinates $w_j = z_j/z_0$, the Fubini–Study form coincides with

$$i \sum_j dw_j \wedge d\bar{w}_j,$$

which is a multiple of the standard symplectic form Ω on \mathbb{C}^n described in Example 3.14.

(b) Notice that if an S^1 -action on a smooth manifold M is Hamiltonian with respect to a symplectic form ω , then it is Hamiltonian with respect to $c\omega$, for every nonzero real number c .

Since the Fubini–Study form is invariant with respect to the tautological $U(n+1)$ -action on the connected manifold $\mathbb{C}\mathbb{P}^n$, and this action is transitive, we deduce that up to a multiplicative constant there exists exactly one $U(n+1)$ -invariant symplectic form on $\mathbb{C}\mathbb{P}^n$.

The computations in Example 3.36 show that the given S^1 -action is Hamiltonian with respect to some $U(n+1)$ -invariant symplectic form and thus with respect to *any* $U(n+1)$ -invariant form. In particular, this action is Hamiltonian with respect to the Fubini–Study form. Moreover, the computations in the same Example 3.36 show that a moment map must have the form

$$\mu(\mathbf{z}) = c \frac{\sum_j j |z_j|^2}{|\mathbf{z}|^2},$$

where c is a real nonzero constant. This constant can be determined by verifying at a (non-fixed) point in $\mathbb{C}\mathbb{P}^n$ the equality $d\mu = X \lrcorner \omega$, where X is the infinitesimal generator of the S^1 -action.

If we work in the coordinate chart $z_0 \neq 0$ with $w_k = z_k/z_0$ then

$$\omega = i\partial\bar{\partial}(1 + |w|^2) = i\partial \frac{\bar{\partial}|w|^2}{1 + |w|^2}.$$

The projective line L in $\mathbb{C}\mathbb{P}^n$ described by $w_2 = \cdots = w_n = 0$ is S^1 -invariant, and along this line we have

$$\begin{aligned} \omega|_L &= i\partial \frac{\bar{\partial}|w_1|^2}{1 + |w_1|^2} = i\partial \left(\frac{1}{1 + |w_1|^2} w_1 d\bar{w}_1 \right) \\ &= i \frac{dw_1 \wedge d\bar{w}_1}{1 + |w_1|^2} - i \frac{|w_1|^2 dw_1 \wedge d\bar{w}_1}{(1 + |w_1|^2)^2} \\ &= \frac{i}{(1 + |w_1|^2)^2} dw_1 \wedge d\bar{w}_1. \end{aligned}$$

If we write $w_1 = x_1 + iy_1$, then we deduce that

$$\omega|_L = \frac{2dx_1 \wedge dy_1}{(1 + x_1^2 + y_1^2)^2}.$$

In these coordinates we have

$$\mu|_L(w_1) = c \frac{|w_1|^2}{1 + |w_1|^2}, \quad X = -y_1 \partial_{x_1} + x_1 \partial_{y_1}.$$

Along L we have

$$X \lrcorner \omega = -2 \frac{x_1 dx_1 + y_1 dy_1}{(1 + x_1^2 + y_1^2)^2} = - \frac{d|w_1|^2}{(1 + |w_1|^2)^2} = d \frac{|w_1|^2}{1 + |w_1|^2} = \frac{1}{c} d\mu|_L.$$

Thus we can take $c = 1$. □

Remark 5.40. It is interesting to compute the volume of the projective line

$$w_2 = \cdots = w_n = 0$$

with respect to the Fubini–Study form. We have

$$\begin{aligned} \text{vol}_\omega(L) &= 2 \int_{\mathbb{R}^2} \frac{dx_1 \wedge dy_1}{(1 + x_1^2 + y_1^2)^2} \\ &\stackrel{(w_1=r e^{i\theta})}{=} \int_0^{2\pi} d\theta \int_0^\infty \frac{2r dr}{(1 + r^2)^2} \\ &\stackrel{(u=1+r^2)}{=} \int_0^{2\pi} d\theta \int_1^\infty \frac{du}{u^2} = 2\pi. \end{aligned}$$

Thus, if we define the *normalized* Fubini–Study form Φ by

$$\Phi = \frac{i}{2\pi} \partial \bar{\partial} \log |\mathbf{z}|^2,$$

we have

$$\int_{\mathbb{C}\mathbb{P}^n} \Phi^n = 1.$$

We deduce that the action of \mathbb{T}^n given by

$$(e^{2\pi i t_1}, \dots, e^{2\pi i t_n})[z_0, z_1, \dots, z_n] = [z_0, e^{2\pi i t_1} z_1, \dots, e^{2\pi i t_n} z_n]$$

is Hamiltonian with respect to Φ with moment map

$$\mu(\mathbf{z}) = \frac{1}{|\mathbf{z}|^2} (|z_1|^2, \dots, |z_n|^2).$$

The image of the moment map is the n -simplex

$$\Delta = \left\{ \boldsymbol{\rho} \in \mathbb{R}_{\geq 0}^n; \sum_i \rho_i \leq 1 \right\}.$$

Its Euclidean volume is $\frac{1}{n!}$ and it is equal to the volume of $\mathbb{C}\mathbb{P}^n$ with respect to the Kähler metric determined by Φ ,

$$\text{vol}_\Phi(\mathbb{C}\mathbb{P}^n) = \frac{1}{n!} \int_{\mathbb{C}\mathbb{P}^n} \Phi^n = \frac{1}{n!}. \quad \square$$

Exercise 5.33 Part (a) is classical; see e.g., [Ni, Section 3.4.4].

For part (b), assume $\mathbb{T} = (\mathbb{R}/\mathbb{Z})^n$. Thus we can choose global angular coordinates $(\theta^1, \dots, \theta^n)$ on the Lie algebra $\mathfrak{t} \cong \mathbb{R}$ such that the characters of \mathbb{T}^n are described by the functions

$$\chi_{\mathbf{w}}(\theta^1, \dots, \theta^n) = \exp(2\pi i (w_1 \theta^1 + \dots + w_n \theta^n)), \quad \mathbf{w} \in \mathbb{Z}^n.$$

We obtain a basis ∂_{θ^j} on \mathfrak{t} and a dual basis $d\theta^j$ on \mathfrak{t}^* . We denote by (ξ_j) the coordinates on \mathfrak{t}^* defined by the basis $(d\theta^j)$. In the coordinates (ξ_j) the lattice of characters is defined by the conditions

$$\xi_j \in \mathbb{Z}, \quad \forall j = 1, \dots, n.$$

The normalized Lebesgue measure on \mathbb{T}^* is therefore $d\xi_1 \cdots d\xi_n$. Moreover,

$$\int_{\mathbb{R}^n/\mathbb{Z}^n} d\theta^1 \wedge \cdots \wedge d\theta^n = 1.$$

The one-parameter subgroup of \mathbb{T} generated by ∂_{θ^j} defines a flow Φ_t^j on M , and we denote by X_j its infinitesimal generator. Using the coordinates (ξ_j) on \mathbb{T}^* we can identify the moment map with a smooth map

$$\mu : M \rightarrow \mathbb{R}^n, \quad p \mapsto \mu(p) = (\xi_1(p), \dots, \xi_n(p)).$$

Since the action is Hamiltonian, we deduce

$$d\xi_j = X_j \lrcorner \omega, \quad j = 1, \dots, n.$$

Fix a point

$$\xi^0 = (\xi_1^0, \dots, \xi_n^0) \in \text{int } P$$

and a point p_0 in the fiber $\mu^{-1}(\xi^0) \subset M^*$.

The vector ξ^0 is a regular value for μ , and since μ is a proper map we deduce from the Ehresmann fibration theorem that there exists an open contractible neighborhood U of the point ξ^0 in $\text{int } P$ and a diffeomorphism

$$\mu^{-1}(U) \longrightarrow \mu^{-1}(\xi^0) \times U.$$

In particular, there exists a smooth map $\sigma : U \rightarrow M$ which is a section of μ , i.e., $\mu \circ \sigma = \mathbb{1}_U$. We now have a diffeomorphism

$$\mathbb{T} \times U \rightarrow \mu^{-1}(U), \quad \mathbb{T} \times U \ni (t, \xi) \longmapsto t \cdot \sigma(\xi).$$

Using the diffeomorphism Ψ^{-1} we pull back the angular forms $d\theta^j$ on \mathbb{T} to closed 1-forms $\varphi^j = (\Psi^{-1})^* d\theta^j$ on $\mu^{-1}(U)$. Observe that

$$X_j \lrcorner \varphi^k = \delta_j^k = \text{Kronecker delta.}$$

The collection of 1-forms $\{\varphi^j, d\xi^k\}$ trivializes T^*M over $\mu^{-1}(U)$, and thus along $\mu^{-1}(U)$ we have a decomposition of the form

$$\omega = \sum_{j,k} (a_{jk} \varphi^j \wedge \varphi^k + b_j^k \varphi^j \wedge d\xi_k + c^{jk} d\xi_j \wedge d\xi_k).$$

Since

$$X_j \lrcorner \omega = d\xi_j, \quad X_j \lrcorner d\xi_k = \{\xi_j, \xi_k\} = 0$$

we deduce

$$a_{jk} = 0$$

and

$$\omega = \sum_k \varphi^j \wedge d\xi_k + \sum_{j,k} c^{jk} d\xi_j \wedge d\xi^k.$$

Hence

$$\Psi^* \omega = \sum_k \sum_j d\theta^j \wedge d\xi_k + \sum_{j,k} c^{jk} d\xi_j \wedge d\xi^k.$$

Since ω is closed, we deduce that the coefficients c^{jk} must be constant along the orbits, i.e. they are pullbacks via μ of functions on \mathfrak{t}^* . In more concrete terms, the functions c^{jk} depend only on the variables ξ^j . We now have a closed 2-form on U ,

$$\eta = \sum_{j,k} c^{jk} d\xi_j \wedge d\xi_k.$$

Since U is closed there exists a 1-form $\lambda = \sum_j \lambda^j d\xi_j$ such that

$$\eta = -d\lambda, \quad \lambda = \sum_k \lambda^k(\xi) d\xi_k \in \Omega^1(U).$$

For every $\xi \in U$ denote by $[\lambda(\xi)]$ the image of the vector $\lambda(\xi) \in \mathbb{R}^n$ in the quotient $\mathbb{R}^n/\mathbb{Z}^n$. If we now define a new section

$$s(\xi) = [\lambda(x)] \cdot \sigma(\xi),$$

we obtain a new diffeomorphism

$$\Psi_\lambda : \mathbb{T} \times U, \quad (t, \xi) \mapsto t \cdot s(\xi) = [\lambda(\xi)]\Psi(t, \xi).$$

Observe that

$$\Psi_\lambda^* \omega = \sum_k d(\theta^k + \lambda^k) \wedge d\xi_k - \sum_k d\lambda^k \wedge d\xi_k = \sum_k d\theta^k \wedge d\xi^k.$$

Thus

$$\frac{1}{n!} \Psi_\lambda \omega^n = d\theta^1 \wedge \cdots \wedge d\theta^n \wedge d\xi_1 \wedge \cdots \wedge d\xi_n,$$

so that

$$\int_{\mu^{-1}(U)} \frac{1}{n!} \omega^n = \left(\int_{\mathbb{R}^n/\mathbb{Z}^n} d\theta^1 \wedge \cdots \wedge d\theta^n \right) \left(\int_U d\xi_1 \wedge \cdots \wedge d\xi_n \right) = \text{vol}(U).$$

The result now follows using a partition-of-unity argument applied to an open cover of $\text{int } P$ with the property that above each open set of this cover, μ admits a smooth section. \square

Remark 5.41. The above proof reveals much more, namely that in the neighborhood of a generic orbit of the torus action we can find coordinates (ξ_j, θ^k) (called “*action-angle coordinates*”) such that all the nearby fibers are described by the equalities $\xi_j = \text{const}$, the symplectic form is described by

$$\omega = \sum_k d\theta^k \wedge d\xi^k,$$

and the torus action is described by

$$t \cdot (\xi_j, \theta^k) = (\xi_j; \theta^k + t^k).$$

This fact is known as the *Arnold–Liouville theorem*. For more about this we refer to [Au]. \square

Exercise 5.35 Mimic the proof of Theorem 3.64 and Corollary 3.69. \square

Exercise 5.36 The group $\mathbb{Z}/2$ acts by conjugation on

$$X(P)^\mathbb{C} := \{[x, y, z] \in \mathbb{C}\mathbb{P}^2; P(x, y, z) = 0\},$$

and $X(P)$ is the set of fixed points of this action. Now use Exercise 5.35 and Corollary 4.14. \square

References

- AF. A. Andreotti, T. Frankel: *The Lefschetz theorem on hyperplane sections*, Ann. of Math. **69**(1953), 713–717.
- Ar. V.I. Arnold: *Mathematical Methods of Classical Mechanics*, Graduate Texts in Math., vol. 60, Springer-Verlag, 1989.
- AGV1. V.I. Arnold, S.M. Gusein-Zade, A.N. Varchenko: *Singularities of Differentiable Maps. Vol. I*, Monographs in Math., vol. 82, Birkhäuser, 1985.
- AGV2. V.I. Arnold, S.M. Gusein-Zade, A.N. Varchenko: *Singularities of Differentiable Maps. Vol. II*, Monographs in Math., vol. 83, Birkhäuser, 1985.
- A. M.F. Atiyah: *Convexity and commuting Hamiltonians*, Bull. London Math. Soc., **14**(1982), 1 -15.
- AB1. M.F. Atiyah, R. Bott: *Yang-Mills equations over Riemann surfaces*, Phil. Trans.R. Soc. London A, **308**(1982), 523 -615.
- AB2. M.F. Atiyah, R. Bott: *The moment map and equivariant cohomology*, Topology, **23**(1984), 1 -28.
- Au. M. Audin: *Torus Actions on Symplectic Manifolds*, 2nd edition, Birkhäuser, 2005.
- ABr. D.M. Austin, P.J. Braam: *Morse–Bott theory and equivariant cohomology*, *The Floer Memorial Volume*, p. 123–183, Progr. in Math., 133, Birkhäuser, Basel, 1995
- BaHu. A. Banyaga, D. Hurtubise: *Lectures on Morse Homology*, Kluwer Academic Publishers, 2005.
- Bo. A. Borel: *Seminar of Transformation Groups*, Annals of Math. Studies, vol. 46, Princeton University Press, 1960.
- B1. R. Bott: *Nondegenerate critical manifolds*, Ann. of Math., **60**(1954), 248–261.
- B2. R. Bott: *Lectures on Morse theory, old and new*, Bull. Amer. Math. Soc. (N.S.) **7**(1982), 331–358.
- B3. R. Bott: *Morse theory indomitable*, Publ. IHES, **68**(1988), 99–114.
- BT. R. Bott, L. Tu: *Differential forms in Algebraic Topology*, Springer-Verlag, 1982.
- BK. L. Bröcker, M. Kuppe: *Integral geometry of tame sets*, Geom. Dedicata, **82**(2000), 285–323.
- Ch. S.S. Chern: *Complex Manifolds Without Potential Theory*, Springer-Verlag, 1968, 1995.

- Co. P. Conner: *On the action of the circle group*, Michigan Math. J., **4**(1957), 241–247.
- Do. A. Dold: *Lectures on Algebraic Topology*, Springer-Verlag, 1980.
- DV. I.A. Dynnikov, A.P. Vesselov: *Integrable Morse flows*, math.dg-ga/956004.
- Ehr. Ch. Ehresmann: *Sur l'espaces fibrés différentiables*, C.R. Acad. Sci. Paris, **224**(1947), 1611–1612.
- Fed. H. Federer: *Geometric Measure Theory*, Springer-Verlag, 1969.
- Fl. A. Floer: *Witten's complex and infinite-dimensional Morse theory*, J. Differential Geom. **30**(1989), 207–221.
- Fra. T. Frankel: *Fixed points and torsion on Kähler manifolds*, Ann. of Math. **70**(1959), 1–8.
- GKZ. I.M. Gelfand, M.M. Kapranov, A.V. Zelevinski: *Discriminants, Resultants and Multidimensional Determinants*, Birkhäuser, 1994.
- GKM. M. Goresky, R. Kottwitz, R. MacPherson: *Equivariant cohomology, Koszul duality and the localization theorem*, Invent. Math. **131**(1998), 25–83.
- GH. P. Griffiths, J. Harris: *Principles of Algebraic Geometry*, John Wiley & Sons, 1978.
- Gu. M. Guest: *Morse theory in the 1990's*, <http://www.comp.metro-u.ac.jp/~martin/RESEARCH/new.html>
- GS. V. Guillemin, S. Sternberg: *Convexity properties of the moment map*, Invent. Math., **97**(1982), 485–522.
- HL. F.R. Harvey, H.B. Lawson: *Morse theory and Stokes' theorem*, Surveys in differential geometry, 259–311, Surv. Differ. Geom., VII, Int. Press, Somerville, MA, 2000. <http://www.math.sunysb.edu/~blaine/>
- Ha. A. Hatcher: *Algebraic Topology*, Cambridge University Press, 2002. <http://www.math.cornell.edu/hatcher/AT/ATpage.html>
- Hau. J.-C. Hausmann: *Sur la topologie des bras articulés*, in the volume *Algebraic Topology 1989 Poznan. Proceedings*, S. Jackowski, B. Oliver, K. Pawalowski, Lect. Notes in Math., vol. 1474, 146–169.
- Helg. S. Helgason: *Differential Geometry, Lie Groups, and Symmetric Spaces*, Graduate Studies in Math. v. 34, Amer. Math. Soc., 2001.
- Hir. M. Hirsch: *Differential Topology*, Springer-Verlag, 1976.
- Hs. W.-Y. Hsiang: *Cohomological Theory of Compact Transformation Groups*, Springer-Verlag, 1975.
- HZ. S. Hussein-Zade: *The monodromy groups of isolated singularities of hypersurfaces*, Russian Math. Surveys, **32:2**(1977), 23–69.
- KM. M. Kapovich, J. Millson: *On the moduli space of polygons in the Euclidean plane*, J. Diff. Geom., **42**(1995), 430–464.
- Lam. K. Lamotke: *The topology of complex projective varieties after S. Lefschetz*, Topology, **20**(1981), 15–51.
- La. F. Laudenbach: *On the Thom–Smale complex*, Astérisque, vol. 205(1992), Soc. Math. France.
- Lef. S. Lefschetz: *L'Analysis Situs et la Géométrie Algébrique*, Gauthier Villars, Paris, 1924.
- Lo. E.J.N. Looijenga: *Isolated Singular Points on Complete Intersections*, London Math. Soc. Lect. Note Series, vol. 77, Cambridge University Press, 1984.

- Mac. S. Mac Lane: *Homology*, Classics in Mathematics, Springer-Verlag, 1995.
- McS. D. McDuff, D. Salamon: *Introduction to Symplectic Topology*, Oxford University Press, 1995.
- M1. J.W. Minor: *Manifolds homeomorphic to the 7-sphere*, Ann. Math. **64**(1956), 399–405.
- M2. J.W. Milnor: *Topology from a Differentiable Viewpoint*, Princeton University Press, 1965.
- M3. J.W. Milnor: *Morse Theory*, Annals of Math Studies, vol. 51, Princeton University Press, 1973.
- M4. J.W. Milnor: *Lectures on the h-cobordism*, Princeton University Press, 1965.
- MS. J. Milnor, J.D. Stasheff: *Characteristic Classes*, Ann. Math. Studies 74, Princeton University Press, Princeton, 1974.
- Ni. L.I. Nicolaescu: *Lectures on the Geometry of Manifolds*, World Scientific, 1996.
- Re. G. Reeb: *Sur les points singuliers d'une forme de Pfaff complètement intégrable ou d'une fonction numérique*, C. R. Acad. Sci. Paris, **222**(1946), 847–849.
- Rolf. D. Rolfsen: *Knots and Links*, Publish or Perish, 1976.
- Sal. D. Salamon: *Morse theory, the Conley index and Floer homology*, Bull. London Math. Soc., **22**(1990), 113–140.
- Sch. M. Schwarz: *Morse Homology*, Birkhäuser, 1993.
- S. J.P. Serre: *Local Algebra*, Springer-Verlag, 2000.
- SV. D. Shimamoto, C. Vanderwaart: *Spaces of polygons in the plane and Morse theory*, Amer. Math. Monthly, **112**(2005), 289–310.
- Sm. S. Smale: *On gradient dynamical systems*, Ann. of Math., **74**(1961), 199–206.
- Spa. E.H. Spanier: *Algebraic Topology*, Springer Verlag, 1966.
- Str. D.J. Struik: *Lectures on Classical Differential Geometry*, 2nd edition, Dover Publications, 1988.
- Th. R. Thom: *Sur une partition en cellules associées á une fonction sur une variété*, C.R. Acad. Sci Paris, **228**(1949), 973–975.
- W. H. Whitney: *Geometric Integration Theory*, Princeton University Press, 1957.
- Wit. E. Witten: *Supersymmetry and Morse theory*, J. Differential Geom., **17**(1982), 661–692.

Index

- BS^1 , 135
- DF_x , 1
- $E(1)$, 156
- H_{f,x_0} , 6
- I_ω , 107
- $M_f(t)$, 7
- PD_M , 157
- S^1 -map, 139
- S^1 -space, 139
 - finite type, 143
 - negligible, 145
- $S^\pm(p_0, \varepsilon)$, 56
- $TM^{0,1}$, 93
- $TM^{1,0}$, 93, 102
- $T^*M^{0,1}$, 94
- $T^*M^{1,0}$, 94
- $T_\Sigma X$, 32
- $W^\pm(p_0)$, 56
- $[f]$, 13
- \mathbf{Cr}_F , 1
- Δ_F , 1
- $\text{Fix}_G(M)$, 118
- \mathcal{J}_ω , 99
- $\Lambda^{p,q}T^*M$, 94
- $\mathcal{O}(m)$, 136
- $\Omega^{p,q}(M)$, 94
- $\Sigma(2, 3, 5)$, 31
- $\mathbb{C}[z]$ -module
 - finitely generated, 144
 - support of, 144
 - negligible, 145
- \mathbb{D}^k , 23
- \mathbb{U}_1 , 137
- \mathbb{U}_n , 136
- cat_M , 84
- \mathbf{i} , XI
- $\lambda(f, S)$, 71
- $\lambda(f, p_0)$, 7
- \mathbf{lk} , 26
- $L^{k,2}$, 28
- $\mu_f(\lambda)$, 7
- $\nabla^\omega H$, 108
- \mathfrak{h} , XI
- \succ , 47
- \mathbb{K}^r , XI
- $\underline{so}(n)$, XI
- $\underline{u}(n)$, XI, 106
- $b_k(X)$, 48
- $e_\lambda(p)$, 37, 50, 51
- $i^!$, 168
- $i_!$, 166
- $\mathbb{P}(d, N)$, 152
- \mathbf{var}_γ , 188
- $\text{CL}(M)$, 84
- adapted
 - coordinates, 16, 35
- Alexander cohomology, 85
- almost complex structure, *see* structure
- Betti number, 169, 171
- Betti numbers, 48
- blowup, 156
- Cartan formula, 108
- cell, 23

- character, 206
- classifying space, 137
- coadjoint orbit, 104, 113
- cohomology
 - De Rham, 188, 207
 - equivariant, 139
 - singular, 129
- conormal space, 123
- critical point, 1, 162
 - hessian, 6
 - index, 7
 - nondegenerate, 6
- cuplength, 84
- curve, 3
 - cubic
 - pencil, 156
- cycle
 - effective, 170
 - invariant, 165, 191
 - primitive, 170
 - vanishing, 164, 175, 191

- Dehn twist, 190
- divisor, 152
- duality
 - Poincaré, 157, 166
 - Poincaré–Lefschetz, 67, 179

- Eilenberg–Mac Lane space, 143
- elliptic fibration, 156
- ENR, 143
- Euler
 - characteristic, 48
 - class, 137, 181
- fibration
 - homotopy lifting property, 173
 - Lefschetz, 158
- finite type, 143
- five lemma, 165
- flag, 106
 - manifold, 107
- flow, 36, 45, 55, 58, 67, 108, 182
 - Hamiltonian, 108
 - Morse–Smale, 69
- framing, 24
- Fubini–Study form, 103, 205, 228
- gap condition, 51

- Gauss lemma, 147
- genus formula, 161
- germ, 13
- graded vector space, 46
 - admissible, 46
- gradient, 35
- Grassmannian, 87, 92, 107
- group
 - action, 103, 104, 111, 139
 - dual right, 139
 - effective, 103, 116, 120, 133
 - fixed point set of, 118, 120, 124, 145, 150
 - Hamiltonian, 112, 117, 120, 149
 - left, 139
 - right, 139
 - symplectic, 111
 - Lie, *see* Lie
- Gysin
 - map, 138
 - sequence, 138

- Hamilton equations, 109
- Hamiltonian, 108
 - vector field, 108
- Hamiltonian action, *see* group
- handle, 31
 - cocore, 31
 - core, 31
 - index of, 31, 41
- harmonic oscillator, 109, 112
- hessian, 6
- Hodge theory, 168
- homogeneous space, 103
- homology equation, 13
- homology sphere, 31
- homotopy method, 12
- Hopf bundle, 136
- Hopf link, 26
- Hopf surface, 169

- index, 7
- intersection form, 166

- Jacobi identity, 106
- Jacobian ideal, 14

- Key Lemma, 161, 163
- knot, 25

- diagram, 28
 - crossings, 29
- group
 - Wirtinger presentation, 29
- group of, 28
- longitude of, 26
- meridian of, 26
- parallel, 28
 - blackboard, 29
- trefoil, 28, 29
- Kronecker pairing, 67, 157, 166, 179
- Lagrangian
 - submanifold, 204
 - exact, 204
 - subspace, 203
- lattice, 206
- Lefschetz decomposition, 170
- lemma
 - Hadamard, 14
- Lie
 - algebra, 103, 106
 - group, 103, 104, 112, 114
 - adjoint representation, 104
 - coadjoint action, 104
- line bundle, 136
 - associated, 136
 - universal, 137
- linear system, 152
 - base locus of, 152, 157
- linkage, 3
- linking number, 26
- Lusternik–Schnirelmann
 - category, 84
- manifold, 1
 - algebraic, 92, 98, 103, 157
 - modification of, 152
 - complex, 93, 102
 - Kähler, 102
 - stable, 56
 - Stein, 92
 - symplectic, 100, 102
 - unstable, 56
- map
 - critical point of, 1
 - critical set of, 1
 - critical value of, 1
 - degree of, 161
 - differential of, 1
 - discriminant set of, 1
 - regular point of, 1
 - regular value of, 1
 - variation, 178
- Mayer–Vietoris sequence, 147
- min-max
 - data, 75
 - principle, 75
 - theory, 75
- moment map, 112
- monodromy, 178
 - group, 190, 191
 - homological, 178
 - local, 175, 178
 - relative, 178
- Morse
 - coindex, 71
 - function, 6, 19, 55, 57, 154, 172
 - completable, 50
 - excellent, 21
 - exhaustive, 21, 34
 - nonresonant, 21, 58
 - perfect, 50, 54, 117, 200
 - resonant, 21
 - self-indexing, 61
 - index, 71, 150
 - inequalities, 49
 - abstract, 47
 - weak, 47
 - lemma, 12, 16
 - with parameters, 71
 - number, 7
 - polynomial, 7, 49, 72
- Morse–Bott
 - function, 71, 117, 124, 130
 - completable, 73
 - perfect, 74, 91, 135, 149
 - inequalities, 73, 150
 - polynomial, 72
- Morse–Floer complex, 67
- Morse–Smale
 - pair, 61
 - vector field, 61
- Mountain-pass
 - Lemma, 77
 - points, 76
- negligible

- $\mathbb{C}[z]$ -module, 145
- S^1 -space, 145, 147
- set, 1, 20
- normal bundle
 - negative, 71
- Palais–Smale condition, 21
- pencil, 152
 - Lefschetz, 154, 157
 - monodromy group, 190
 - monodromy of, 188
- phase space
 - classical, 101
- Picard–Lefschetz
 - global formula, 188, 191
 - local formula, 181
 - number, 179
- Poincaré
 - dual, 137, 165
 - series, 47, 92
 - sphere, 31, 54
- Poisson bracket, 110
- polyhedron
 - convex, 123
- projection, 161
 - axis of, 154
 - screen of, 154
- projection formula, 157
- projective space, 151
 - dual of, 151
- robot arm, 3, 8, 42
 - configuration, 3
- spectral sequence, 66
 - Leray–Serre, 144
- stabilizer, 104, 121
- standard model, 101, 177
- Stein manifold, 92
- structure
 - almost complex, 93
 - G -tamed, 113
 - tamed, 99
- subadditivity, 48
- submersion, 176
- surgery, 23, 24
 - attaching sphere, 25
 - coefficient, 26
 - trace of, 34, 44
- type of, 24
- symplectic
 - duality, 100, 107
 - form, 99
 - gradient, 108
 - manifold, 100
 - toric, 132
 - orientation, 100
 - pairing, 99
 - basis adapted to, 99
 - structure, 100
 - volume form, 100
- theorem
 - hard Lefschetz, 168
 - Andreotti–Frankel, 92
 - Arnold–Liouville, 233
 - Bott, 72
 - Conner, 149
 - Ehresmann fibration, 156, 160, 163, 173, 176, 231
 - equivariant localization, 145
 - excision, 157, 163, 173
 - fundamental structural, 37, 72, 129
 - Gauss–Bonnet–Chern, 137
 - Gysin, 138
 - Künneth, 158
 - Lefschetz
 - hard, 170
 - Lefschetz hyperplane, 98, 162, 164, 168
 - Lusternik–Schnirelmann, 84
 - moment map convexity, 120
 - Morse–Sard–Federer, 2, 20
 - Poincaré–Lefschetz, 67, 98, 179
 - Thom isomorphism, 72, 129
 - universal coefficients, 165, 166
 - van Kampen, 27
 - weak Lefschetz, 166, 167
 - Whitney embedding, 17, 21
- thimble, 175, 188
- Thom
 - class, 72, 137
 - isomorphism, 72, 138
- Thom–Smale complex, 66
- tunnelling, 67
- vanishing
 - cycle, 164, 175, 188

sphere, 175, 188
vector field, 5, 13, 108
gradient like, 35, 55
Hamiltonian, 108

Veronese embedding, 153

Wirtinger presentation, 29
writhe, 30