



Piper Seminole

PA-44-180

1995-Models & Newer

Note: At the time of issuance, this manual was an exact duplicate of the FAA-Approved Pilot's Operating Handbook, Airplane Flight Manual, or Owner's Manual. Use for training and familiarization purposes only. It will not be kept current and cannot be used as a substitute for the FAA-Approved POH / AFM / Owner's Manual required for operation of the airplane.

APPLICABILITY

Application of this handbook is limited to the specific Piper PA-44-180 model airplane designated by serial number and registration number on the face of the title page of this handbook.

WARNING

THIS HANDBOOK CANNOT BE USED FOR OPERATIONAL PURPOSES UNLESS KEPT IN A CURRENT STATUS.

WARNING

INSPECTION, MAINTENANCE AND PARTS REQUIREMENTS FOR ALL NON-PIPER APPROVED STC INSTALLATIONS ARE NOT INCLUDED IN THIS HANDBOOK. WHEN A NON-PIPER APPROVED STC INSTALLATION IS INCORPORATED ON THE AIRPLANE, THOSE PORTIONS OF THE AIRPLANE AFFECTED BY THE INSTALLATION MUST BE INSPECTED IN ACCORDANCE WITH THE INSPECTION PROGRAM PUBLISHED BY THE OWNER OF THE STC. SINCE NON-PIPER APPROVED STC INSTALLATIONS MAY CHANGE SYSTEMS INTERFACE, OPERATING CHARACTERISTICS AND COMPONENT LOADS OR STRESSES ON ADJACENT STRUCTURES, PIPER PROVIDED INSPECTION CRITERIA MAY NOT BE VALID FOR AIRPLANES WITH NON-PIPER APPROVED STC INSTALLATIONS.

REVISIONS

The Pilot's Operating Handbook and FAA Approved Airplane Flight Manual, with the exception of the equipment list, is kept current by revisions which are distributed to the registered airplane owners. The equipment list was current at the time the airplane was licensed by the manufacturer and thereafter must be maintained by the owner.

Revision material will consist of information necessary to add, update or correct the text of the present handbook and/or to add supplemental information to cover added airplane equipment.

I. Identifying Revised Material

Each handbook page is dated at the bottom of the page showing both the date of original issue and the date of the latest revision. Revised text and illustrations are indicated by a black vertical line located along the outside margin of each revised page opposite the revised, added, or deleted information. A vertical line next to the page number indicates that an entire page has been changed or added.

Vertical black lines indicate current revisions only. Correction of typographical or grammatical errors or the physical relocation of information on a page will not be indicated by a symbol.

II. Revision Procedure

Revisions will be distributed whenever necessary as complete page replacements or additions and shall be inserted into the handbook in accordance with the instructions given below.

1. Revision pages will replace only pages with the same page number.
2. Insert all additional pages in proper numerical order within each section. Discard old page.
3. Insert page numbers followed by a small letter in direct sequence with the same commonly numbered page.



ORIGINAL PAGES ISSUED

The original pages issued for this handbook prior to revision are given below:



Title, ii through viii, 1-1 through 1-12, 2-1 through 2-10, 3-1 through 3-38, 4-1 through 4-42, 5-1 through 5-34, 6-1 through 6-18, 7-1 through 7-46, 8-1 through 8-20, 9-1 through 9-30, 10-1 through 10-4.

PILOT'S OPERATING HANDBOOK LOG OF REVISIONS

Current Revisions to the PA-44-180, Seminole Pilot's Operating Handbook,
 REPORT: VB-1616 issued July 12, 1995.

Revision Number and Code	Revised Pages	Description of Revisions	FAA Approved Signature and Date
Rev. 1 (PR951025)	9-i 9-31 thru 9-42	Revised Table of Contents. Added Supplement 3 (Bendix/King KLN 89B GPS Navigation System).	 Peter E. Peck
Rev. 2 (PR951129)	v 3-5 4-iii 4-iv 4-7 5-23 5-32 5-33 9-21 10-i 10-ii	Added Rev. 2 to Log of Revs. Revised header. Revised footer. Revised footer. Revised paragraphs 4.5b and 4.5c. Revised Figure 5-17. Revised Figure 5-31. Revised Figure 5-33. Revised page number. Added page. Added page.	 Peter E. Peck Nov. 29, 1995 Date
Rev. 3 (PR960109)	v 9-i 9-43 thru 9-54	Added Rev. 3 to Log of Revs. Revised Table of Contents. Added Supplement 4 (Bendix/King KLN 90B GPS Navigation System).	 Peter E. Peck Jan. 9, 1996 Date

PILOT'S OPERATING HANDBOOK LOG OF REVISIONS (cont)

Revision Number and Code	Revised Pages	Description of Revisions	FAA Approved Signature and Date
Rev. 4 (PR960604)	vi 2-6 2-7 3-ii 3-iii 3-iv 3-v 3-1 3-4 3-12 3-13 3-24 3-35 5-31 7-24 7-45 7-46 8-2 8-17	Added Rev. 4 to Log of Revs. Revised Para. 2.25 Revised Para. 2.27 Revised Table of Contents Revised Table of Contents Revised Table of Contents Revised Table of Contents Revised Para. 3.1 Revised Para. 3.5a Revised Para. 3.5g Typo Revised Para. 3.5g Revised Para. 3.9e (3.5a) Typo Revised Para. 3.29 (3.5k) Typo Revised Fig. 5-29 Revised Para. 7.17 Revised Para. 7.35 Revised Para. 7.35 Revised Para. 8.3 Revised Para. 8.33 Typo	 Peter E. Peck June 4, 1996 Date
Rev. 5 (PR970206)	vi 2-8	Added Rev. 5 to Log of Revs. Revised Para. 2.27	 Peter E. Peck February 6, 1997 Date
Rev. 6 (PR980620)	vi 7-11 9-i 9-55 thru 9-66	Added Rev. 6 to Log of Revs. Revised Para. 7.9 Revised T.O.C. Added Supplement 5 KX-155 Comm/Nav	 Peter E. Peck June 20, 1998 Date

PILOT'S OPERATING HANDBOOK LOG OF REVISIONS (cont)

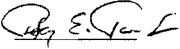
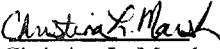
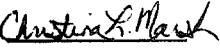
Revision Number and Code	Revised Pages	Description of Revisions	FAA Approved Signature and Date
Rev. 7 (PR981105)	vi-a vi-b 9-i 9-3 9-4 thru 9-24	Added page & Rev. 7 to L of R Added page. Revised Table of Contents. Revised Supplement 1. Deleted pages.	 Peter E. Peck <u>Nov. 5, 1998</u> Date
Rev. 8 (PR991130)	vi-a 9-i 9-67 thru 9-74 9-75 thru 9-76 9-77 thru 9-78	Added Rev. 8 to L of R. Revised T of C. Added pages and Supplement 6. Added pages and Supplement 7. Added pages and Supplement 8.	 Christina L. Marsh <u>Nov. 30, 1999</u> Date
Rev. 9 (PR000310)	vi-a 9-i 9-79 thru 9-82	Added Rev. 9 to L of R. Revised T of C. Added pages and Supplement 9.	 Christina L. Marsh <u>March 10, 2000</u> Date
Rev. 10 (PR010112)	vi-a vi-b 9-i 9-73 9-83 thru 9-92	Added Rev. 10 to L of R. Added Rev. 10 to L of R. Revised T of C. Revised Section 4. Added pages and Supplement 10.	

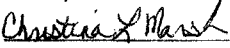
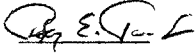
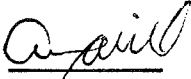

PILOT'S OPERATING HANDBOOK LOG OF REVISIONS (cont)

Revision Number and Code	Revised Pages	Description of Revisions	FAA Approved Signature and Date
Rev. 10 (PR010112) continued	9-93 thru 9-94 9-95 thru 9-100 9-101 thru 9-106 9-107 thru 9-110	Added pages and Supplement 11. Added pages and Supplement 12. Added pages and Supplement 13. Added pages and Supplement 14.	 Christina L. Marsh <u>Jan. 12, 2001</u> Date
Rev. 11 (PR010615)	vi-b 2-9 2-10 9-i	Added Rev. 11 to L of R. Revised Para. 2.27. Revised Para. 2.27. Revised T of C.	 Peter E. Peck <u>June 15, 2001</u> Date
Rev. 12 (PR011101)	vi-b 3-15 3-35 4-10 5-17 thru 5-34 7-10 7-19 7-20 7-25 7-35 7-36 7-37	Added Rev. 12 to L of R. Revised Para. 3.5k. Revised Para. 3.29. Revised Para. 4.5c. Converted fold-out pages. Revised Para. 7.9. Revised Para. 7.17. Revised Para. 7.17 & Figure 7-19. Revised Para. 7.17. Revised Para. 7.25. Revised Figure 7-35. Revised Figure 7-35.	 Albert J. Mill <u>Nov. 1, 2001</u> Date

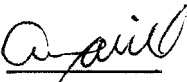
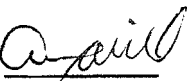
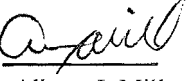

PILOT'S OPERATING HANDBOOK LOG OF REVISIONS (cont)

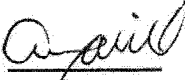
Revision Number and Code	Revised Pages	Description of Revisions	FAA Approved Signature and Date
Rev. 13 (PR011130)	vi-c vi-d 7-21	Added page & Rev. 13 to L of R. Added page. Revised Figure 7-21.	 Albert J. Mill <u>Nov. 30, 2001</u> Date
Rev. 14 (PR020723)	vi-c 5-9 5-16 5-17 5-19 5-21 5-23 5-24 5-25 5-27 5-32 5-33 5-34	Added Rev. 14 to L of R. Revised List of Figures. Added Figure 5-10. Revised Figure 5-11. Revised Figure 5-13. Revised Figure 5-15. Revised Figure 5-17. Revised Figure 5-19. Revised Figure 5-21. Revised Figure 5-25. Revised Figure 5-31. Revised Figure 5-33. Revised Figure 5-35.	 Albert J. Mill <u>July 23, 2002</u> Date
Rev. 15 (PR020801)	vi-c 3-4 3-8 3-23 3-26 4-17 4-38	Added Rev. 15 to L of R. Revised Para. 3.5a. Revised Para. 3.5a. Revised Para. 3.9d. Revised Para. 3.9i. Revised Para. 4.5n. Revised Para. 4.33.	 Albert J. Mill <u>August 1, 2002</u> Date

PILOT'S OPERATING HANDBOOK LOG OF REVISIONS (cont)

Revision Number and Code	Revised Pages	Description of Revisions	FAA Approved Signature and Date
Rev. 16 (PR021108)	vi-d 2-8 7-35 7-35a 7-35b 9-i 9-111 thru 9-114	Added Rev. 16 to L of R. Revised Para. 2.27. Relocated info. to page 7-35a. Added page, revised Para. 7.25 & relocated info. from page 7-35. Added page. Revised T of C. Added pages and Supplement 15.	 Albert J. Mill <u>Nov. 8, 2002</u> Date
Rev. 17 (PR030120)	iii iv vi-d 3-iii 3-iv 3-29 3-35 4-33 8-1 8-1a 8-1b 8-2 9-i 9-46 9-112 9-115 thru 9-124	Added Warning and moved info. to page iv. Moved info. from page iii. Added Rev. 17 to L of R. Revised T of C. Revised T of C. Revised Para. 3.13. Added Para. 3.30. Revised Para. 4.27. Moved info. to page 8-1b and revised Para. 8.1. Added page and revised Para. 8.1. Added page and moved info. from pages 8-1 and 8-2. Moved info. to page 8-1b and revised Para. 8.3. Revised T of C. Revised Section 3. Revised Section 1. Added pages and Supplement 16.	 Albert J. Mill <u>Jan. 20, 2003</u> Date

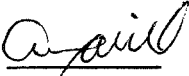
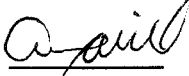
PILOT'S OPERATING HANDBOOK LOG OF REVISIONS (cont)

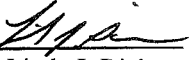
Revision Number and Code	Revised Pages	Description of Revisions	FAA Approved Signature and Date
Rev. 18 (PR040120)	vi-e vi-f 7-8 9-i 9-125 thru 9-128	Added page & Rev. 18 to L of R. Added page. Revised Figure 7-7. Revised T of C. Added pages and Supplement 17.	 Albert J. Mill <u>Jan. 20, 2004</u> Date
Rev. 19 (PR040728)	vi-e 4-15 4-16 4-32 4-33	Added Rev. 19 to L of R. Revised para. 4.5i & 4.5j. Revised para. 4.5m. Revised para. 4.25a. Revised para. 4.25b & 4.27.	 Albert J. Mill July 28, 2004
Rev. 20 (PR050425)	vi-e 3-iii 3-iv 3-11 3-12 3-31 3-32	Added Rev. 20 to L of R. Revised T of C. Revised T of C. Revised para. 3.5f. Revised para. 3.5g. Revised para. 3.19b. Revised para. 3.21 typo.	 Linda J. Dicken April 25, 2005
Rev. 21 (PR051101)	vi-e 7-5 7-8 7-8a 7-8b 7-11	Added Rev. 21 to L of R. Revised para. 7.7. Revised Figure 7-7. Added page and revised Figure 7-7. Added page. Revised para. 7.9.	 Linda J. Dicken Nov. 1, 2005

PILOT'S OPERATING HANDBOOK LOG OF REVISIONS (cont)

Revision Number and Code	Revised Pages	Description of Revisions	FAA Approved Signature and Date

TABLE OF CONTENTS

SECTION 1	GENERAL
SECTION 2	LIMITATIONS
SECTION 3	EMERGENCY PROCEDURES
SECTION 4	NORMAL PROCEDURES
SECTION 5	PERFORMANCE
SECTION 6	WEIGHT AND BALANCE
SECTION 7	DESCRIPTION AND OPERATION OF THE AIRPLANE AND ITS SYSTEMS
SECTION 8	AIRPLANE HANDLING, SERVICING AND MAINTENANCE
SECTION 9	SUPPLEMENTS
SECTION 10	OPERATING TIPS

THIS PAGE INTENTIONALLY LEFT BLANK

TABLE OF CONTENTS

SECTION 1

GENERAL

Paragraph No.	Page No.
1.1 Introduction	1-1
1.3 Engine	1-3
1.5 Propeller	1-3
1.7 Fuel	1-4
1.9 Oil	1-4
1.11 Maximum Weights	1-5
1.13 Standard Airplane Weights	1-5
1.15 Baggage Space and Entry Dimensions	1-5
1.17 Specific Loading	1-5
1.19 Symbols, Abbreviations and Terminology	1-7

THIS PAGE INTENTIONALLY LEFT BLANK

**SECTION 1
GENERAL****1.1 INTRODUCTION**

This Pilot's Operating Handbook is designed for maximum utilization as an operating guide for the pilot. It includes the material required to be furnished to the pilot by the Federal Aviation Regulations and additional information provided by the manufacturer and constitutes the FAA Approved Airplane Flight Manual.

This handbook is not designed as a substitute for adequate and competent flight instruction, knowledge of current airworthiness directives, applicable federal air regulations or advisory circulars. It is not intended to be a guide for basic flight instruction or a training manual and should not be used for operational purposes unless kept in a current status.

Assurance that the airplane is in an airworthy condition is the responsibility of the owner. The pilot in command is responsible for determining that the airplane is safe for flight. The pilot is also responsible for remaining within the operating limitations as outlined by instrument markings, placards, and this handbook.

Although the arrangement of this handbook is intended to increase its in-flight capabilities, it should not be used solely as an occasional operating reference. The pilot should study the entire handbook to become familiar with the limitations, performance, procedures and operational handling characteristics of the airplane before flight.

The handbook has been divided into numbered (arabic) sections, each provided with a finger-tip tab divider for quick reference. The limitations and emergency procedures have been placed ahead of the normal procedures, performance and other sections to provide easier access to information that may be required in flight. The Emergency Procedures Section has been furnished with a red tab divider to present an instant reference to the section. Provisions for expansion of the handbook have been made by the deliberate omission of certain paragraph numbers, figure numbers, item numbers and pages noted as being intentionally left blank.

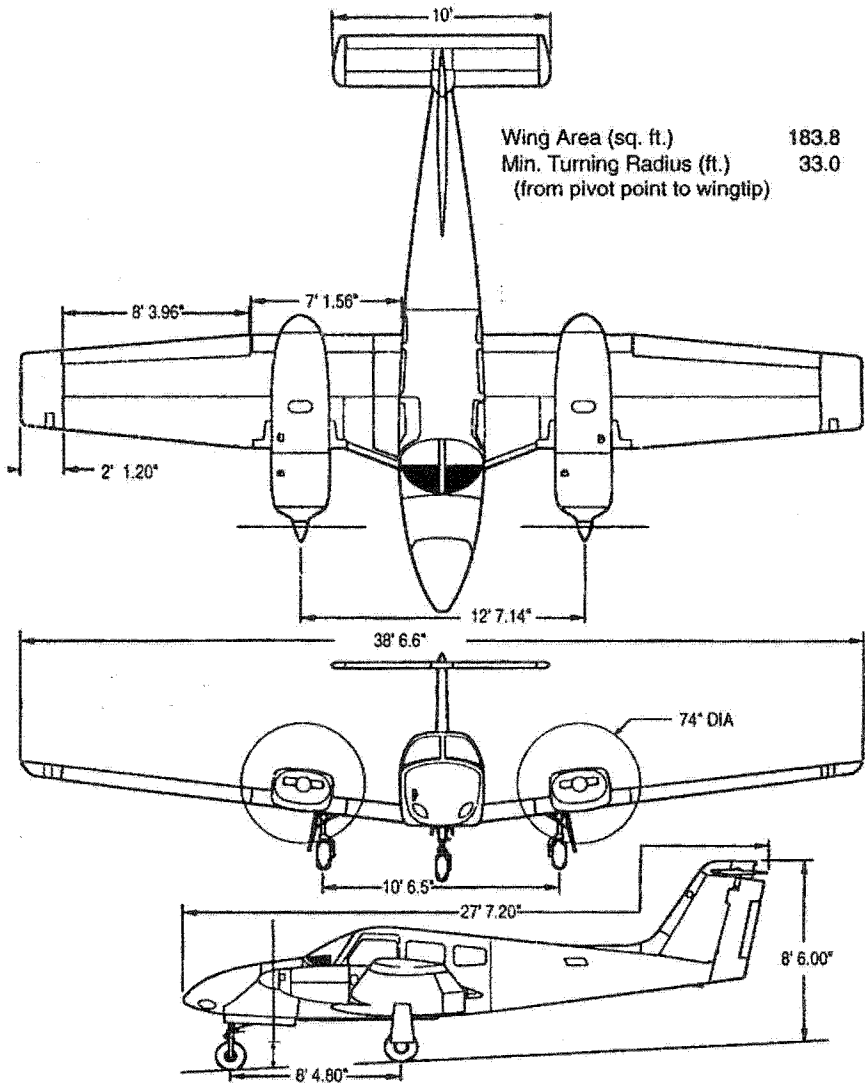

THREE VIEW
Figure 1-1

1.3 ENGINE

(a) Number of Engines	2
(b) Engine Manufacturer	Lycoming
(c) Engine Model Number	
Left	0-360-A1H6
Right	L0-360-A1H6
(d) Rated Horsepower	180
(e) Rated Speed (rpm)	2700
(f) Bore (in.)	5.125
(g) Stroke (in.)	4.375
(h) Displacement (cu. in.)	361
(i) Compression Ratio	8.5:1
(j) Engine Type	Four Cylinder, Direct Drive, Horizontally Opposed, Air Cooled

1.5 PROPELLER

(a) Number of Propellers	2
(b) Propeller Manufacturer	Hartzell
(c) Blade Model	
Left	HC-C2Y(K,R)-2CEUF/ FC7666A-2R
Right	HC-C2Y(K,R)-2CLEUF/ FJC7666A-2R
(d) Number of Blades	2
(e) Propeller Diameter (inches)	
(1) Maximum	74
(2) Minimum	72
(f) Propeller Type	Constant Speed, Hydraulically Actuated, Full Feathering

1.7 FUEL

AVGAS ONLY

- (a) Fuel Capacity (U.S. gal.) (total) 110
- (b) Usable Fuel (U.S. gal.) (total) 108
- (c) Fuel
 - (1) Minimum Grade 100 Green or 100LL Blue Aviation Grade
 - (2) Alternate Fuels Refer to latest revision of Lycoming Service Instruction 1070, except alcohol is *not* approved for use in this airplane.

1.9 OIL

- (a) Oil Capacity (U.S. qts.) (per engine) 8
- (b) Oil Specification Refer to latest revision of Lycoming Service Instruction 1014.
- (c) Oil Viscosity per Average Ambient Temperature for Starting.

Average Ambient Temperature	MIL-L-6082B SAE Grade	MIL-L-22851 Ashless Dispersant SAE Grades
All Temperatures	--	15W-50 or 20W-50
Above 80°F	60	60
Above 60°F	50	40 or 50
30°F to 90°F	40	40
0°F to 70°F	30	30, 40 or 20W-40
0°F to 90°F	20W50	20W50 or 15W50
Below 10°F	20	30 or 20W-30

When operating temperatures overlap indicated ranges, use the lighter grade oil.

NOTE

Refer to the latest issue of Lycoming Service Instruction 1014 (Lubricating Oil Recommendations) for further information.

1.11 MAXIMUM WEIGHTS

(a) Maximum Ramp Weight (lb)	3816
(b) Maximum Takeoff Weight (lb)	3800
(c) Maximum Landing Weight (lb)	3800
(d) Maximum Weights in Baggage Compartment (lb)	200

1.13 STANDARD AIRPLANE WEIGHTS

Refer to Figure 6-5 for the Standard Empty Weight and the Useful Load.

1.15 BAGGAGE SPACE AND ENTRY DIMENSIONS

(a) Compartment Volume (cu. ft.)	24
(b) Entry Dimensions (in.)	
(1) Entry Width (in.)	22
(2) Entry Height(in.)	20

1.17 SPECIFIC LOADING

(a) Wing Loading (lbs. per sq. ft.)	21.1
(b) Power Loading (lbs. per hp)	10.55

THIS PAGE INTENTIONALLY LEFT BLANK

1.19 SYMBOLS, ABBREVIATIONS AND TERMINOLOGY

The following definitions are of symbols, abbreviations and terminology used throughout the handbook and those which may be of added operational significance to the pilot.

(a) General Airspeed Terminology and Symbols

CAS	Calibrated Airspeed means the indicated speed of an airplane, corrected for position and instrument error. Calibrated airspeed is equal to true airspeed in standard atmosphere at sea level.
KCAS	Calibrated Airspeed expressed in Knots.
GS	Ground Speed is the speed of an airplane relative to the ground.
IAS	Indicated Airspeed is the airspeed of an airplane as shown on the airspeed indicator when corrected for instrument error. IAS values published in this handbook assume zero instrument error.
KIAS	Indicated Airspeed expressed in Knots.
TAS	True Airspeed is the airspeed of an airplane relative to undisturbed air which is the CAS corrected for altitude, temperature and compressibility.
KTAS	True Airspeed expressed in Knots.
V _A	Maneuvering Speed is the maximum speed at which application of full available aerodynamic control will not overstress the airplane.

1.19 SYMBOLS, ABBREVIATIONS AND TERMINOLOGY (Continued)

VFE	Maximum Flap Extended Speed is the highest speed permissible with wing flaps in a prescribed extended position.
VLE	Maximum Landing Gear Extended Speed is the maximum speed at which an airplane can be safely flown with the landing gear extended.
VLO	Maximum Landing Gear Operating Speed is the maximum speed at which the landing gear can be safely extended or retracted.
VMCA	Air Minimum Control Speed is the minimum flight speed at which the airplane is directionally controllable as determined in accordance with Federal Aviation Regulations. Airplane certification conditions include one engine becoming inoperative and windmilling, not more than a 5 \bar{D} bank towards the operative engine, takeoff power on operative engine, landing gear up, flaps in takeoff position, and most rearward C.G.
VNE	Never Exceed Speed is the speed limit that may not be exceeded at any time.
VNO	Maximum Structural Cruising Speed is the speed that should not be exceeded except in smooth air and then only with caution.
Vs	Stalling Speed or the minimum steady flight speed at which the airplane is controllable.
VSO	Stalling Speed or the minimum steady flight speed at which the airplane is controllable in the landing configuration.

1.19 SYMBOLS, ABBREVIATIONS AND TERMINOLOGY (Continued)

VSSE	Intentional One Engine Inoperative Speed is a minimum speed selected by the manufacturer for intentionally rendering one engine inoperative in flight for pilot training.
VX	Best Angle-of-Climb Speed is the airspeed which delivers the greatest gain of altitude in the shortest possible horizontal distance.
VY	Best Rate-of-Climb Speed is the airspeed which delivers the greatest gain in altitude in the shortest possible time.

(b) Meteorological Terminology

ISA	International Standard Atmosphere in which: <ol style="list-style-type: none">(1) The air is a dry perfect gas;(2) The temperature at sea level is 15° Centigrade (59° Fahrenheit);(3) The pressure at sea level is 29.92 inches Hg (1013.2 mb)(4) The temperature gradient from sea level to the altitude at which the temperature is -56.5°C (-69.7°F) is -0.00198°C (-0.003564°F) per foot and zero above that altitude.
OAT	Outside Air Temperature is the free air static temperature obtained either from inflight temperature indications or ground meteorological sources, adjusted for instrument error and compressibility effects.
Indicated Pressure Altitude	The number actually read from an altimeter when the barometric subscale has been set to 29.92 inches of mercury (1013.2 millibars).

1.19 SYMBOLS, ABBREVIATIONS AND TERMINOLOGY (Continued)

Pressure Altitude Altitude measured from standard sea-level pressure (29.92 in. Hg) by a pressure or barometric altimeter. It is the indicated pressure altitude corrected for position and instrument error. In this handbook, altimeter instrument errors are assumed to be zero.

Station Pressure Actual atmospheric pressure at field elevation.

Wind The wind velocities recorded as variables on the charts of this handbook are to be understood as the headwind or tailwind components of the reported winds.

(c) Power Terminology

Takeoff Power Maximum power permissible for takeoff.

Maximum Continuous Power Maximum power permissible continuously during flight.

Maximum Climb Power Maximum power permissible during climb.

Maximum Cruise Power Maximum power permissible during cruise.

(d) Engine Instruments

EGT Gauge Exhaust Gas Temperature Gauge

(e) Airplane Performance and Flight Planning Terminology

Climb Gradient The demonstrated ratio of the change in height during a portion of a climb, to the horizontal distance traversed in the same time interval.

1.19 SYMBOLS, ABBREVIATIONS AND TERMINOLOGY (Continued)

Demonstrated Crosswind Velocity	The demonstrated crosswind velocity is the velocity of the crosswind component for which adequate control of the airplane during takeoff and landing was actually demonstrated during certification tests.
Accelerate-stop Distance	The distance required to accelerate an airplane to a specified speed and, assuming failure of an engine at the instant that speed is attained; to bring the airplane to a stop.
Route Segment	A part of a route. Each end of that part is identified by (1) a geographical location or (2) a point at which a definite radio fix can be established.

(f) Weight and Balance Terminology

Reference Datum	An imaginary vertical plane from which all horizontal distances are measured for balance purposes.
Station	A location along the airplane fuselage usually given in terms of distance in inches from the reference datum.
Arm	The horizontal distance from the reference datum to the center of gravity (C.G.) of an item.
Moment	The product of the weight of an item multiplied by its arm. (Moment divided by a constant is used to simplify balance calculations by reducing the number of digits.)
Center of Gravity (C.G.)	The point at which an airplane would balance if suspended. Its distance from the reference datum is found by dividing the total moment by the total weight of the airplane.

1.19 SYMBOLS, ABBREVIATIONS AND TERMINOLOGY (Continued)

C.G. Arm	The arm obtained by adding the airplane's individual moments and dividing the sum by the total weight.
C.G. Limits	The extreme center of gravity locations within which the airplane must be operated at a given weight.
Usable Fuel	Fuel available for flight planning.
Unusable Fuel	Fuel remaining after a runout test has been completed in accordance with governmental regulations.
Standard Empty Weight	Weight of a standard airplane including unusable fuel, full operating fluids and full oil.
Basic Empty Weight	Standard empty weight plus optional equipment.
Payload	Weight of occupants, cargo and baggage.
Useful Load	Difference between takeoff weight, or ramp weight if applicable, and basic empty weight.
Maximum Ramp Weight	Maximum weight approved for ground maneuver. (It includes weight of start, taxi and run-up fuel).
Maximum Takeoff Weight	Maximum weight approved for the start of the takeoff run.
Maximum Landing Weight	Maximum weight approved for the landing touchdown.
Maximum Zero Fuel Weight	Maximum weight exclusive of usable fuel.

TABLE OF CONTENTS
SECTION 2
LIMITATIONS

Paragraph No.	Page No.
2.1 General	2-1
2.3 Airspeed Limitations	2-1
2.5 Airspeed Indicator Markings	2-2
2.7 Power Plant Limitations	2-3
2.9 Power Plant Instrument Markings	2-4
2.11 Weight Limits	2-5
2.13 Center of Gravity Limits	2-5
2.15 Maneuver Limits	2-5
2.17 Flight Load Factors	2-5
2.19 Types of Operation	2-6
2.21 Fuel Limitations	2-6
2.23 Maximum Seating Configuration	2-6
2.25 Gyro Suction Limits	2-6
2.27 Placards	2-7

THIS PAGE INTENTIONALLY LEFT BLANK

SECTION 2
LIMITATIONS

2.1 GENERAL

This section provides the FAA Approved operating limitations, instrument markings, color coding and basic placards necessary for the safe operation of the airplane and its systems.

Limitations associated with those optional systems and equipment which require handbook supplements can be found in Section 9 (Supplements).

2.3 AIRSPEED LIMITATIONS

SPEED	KIAS	KCAS
Never Exceed Speed (VNE) - Do not exceed this speed in any operation.	202	194
Maximum Structural Cruising Speed (VNO) - Do not exceed this speed except in smooth air and then only with caution.	169	165
Design Maneuvering Speed (VA) - Do not make full or abrupt control movements above this speed.		
At 3800 lb Gross Weight	135	133
At 2700 lb Gross Weight	112	112

CAUTION:

Maneuvering speed decreases at lighter weight as the effects of aerodynamic forces become more pronounced. Linear interpolation may be used for intermediate gross weights. Maneuvering speed should not be exceeded while operating in rough air.

2.3 AIRSPEED LIMITATIONS (Continued)

SPEED	KIAS	KCAS
Maximum Landing Gear Extended Speed (VLE) -Do not exceed this speed with landing gear extended.	140	138
Maximum Landing Gear Extension Speed (VLO) - Do not exceed this speed when extending the landing gear.	140	138
Maximum Landing Gear Retraction Speed (VLO) - Do not exceed this speed when retracting the landing gear.	109	109
Maximum Flaps Extended Speed (VFE) - Do not exceed this speed with the flaps extended.	111	109
One Engine Inoperative Best Rate of Climb Speed.	88	90
Air Minimum Control Speed (VMCA) - Lowest airspeed at which airplane is controllable with one engine operating and no flaps. Note: This is a stalled condition.	56	63

2.5 AIRSPEED INDICATOR MARKINGS

MARKING	IAS
Red Radial Line (Never Exceed)	202 KTS
Yellow Arc (Caution Range - Smooth Air Only)	169 KTS to 202 KTS
Green Arc (Normal Operating Range)	57 KTS to 169 KTS

2.5 AIRSPEED INDICATOR MARKINGS (Continued)

MARKING	IAS
White Arc (Flap Down)	55 KTS to 111 KTS
Blue Radial Line (One Engine Inoperative Best Rate of Climb Speed)	88 KTS
Red Radial Line (One Engine Inoperative Air Minimum Control Speed)	56 KTS

2.7 POWER PLANT LIMITATIONS

(a) Number of Engines	2
(b) Engine Manufacturer	Lycoming
(c) Engine Model No.	
Left	0-360-A1H6
Right	L0-360-A1H6
(d) Engine Operating Limits	
(1) Maximum Horsepower	180
(2) Maximum Rotation Speed (RPM)	2700
(3) Maximum Manifold Pressure	Full Throttle
(4) Maximum Cylinder Head Temperature	500°F
(5) Maximum Oil Temperature	245°F
(e) Oil Pressure	
Minimum	25 PSI
Maximum	115 PSI
(f) Fuel Pressure	
Normal Operating Range (green arc)	0.5 PSI to 8 PSI
Minimum (red line)	0.5 PSI
Maximum (red line)	8 PSI
(g) Fuel (AVGAS ONLY) (minimum grade)	100 or 100LL Aviation Grade
(h) Number of Propellers	2
(i) Propeller Manufacturer	Hartzell

2.7 POWER PLANT LIMITATIONS (Continued)

- (j) Propeller Hub and Blade Models
 - Left HC-C2Y(K,R)-2CEUF/
FC7666A-2R
 - Right HC-C2Y(K,R)-2CLEUF/
FJC7666A-2R
- (k) Propeller Diameter (inches)
 - Maximum 74 IN.
 - Minimum 72 IN.

2.9 POWER PLANT INSTRUMENT MARKINGS

- (a) Tachometer
 - Green Arc (Normal Operating Range) 500 to 2700 RPM
 - Red Line (Maximum) 2700 RPM
- (b) Oil Temperature
 - Green Arc (Normal Operating Range) 75°F to 245°F
 - Red Line (Maximum) 245°F
- (c) Oil Pressure
 - Green Arc (Normal Operating Range) 55 PSI to 95 PSI
 - Yellow Arc (Caution Range) (Idle) 25 PSI to 55 PSI
 - Yellow Arc (Warm Up, Taxi & T.O.) 95 PSI to 115 PSI
 - Red Line (Minimum) 25 PSI
 - Red Line (Maximum) 115 PSI
- (d) Fuel Pressure
 - Green Arc (Normal Operating Range) 0.5 PSI to 8 PSI
 - Red Line (Minimum) 0.5 PSI
 - Red Line (Maximum) 8 PSI
- (e) Cylinder Head Temperature
 - Green Arc (Normal Range) 200°F to 500°F
 - Red Line (Maximum) 500°F

2.11 WEIGHT LIMITS

(a) Maximum Ramp Weight	3816 lb
(b) Maximum Takeoff Weight	3800 lb
(c) Maximum Landing Weight	3800 lb
(d) Maximum Weight in Baggage Compartment	200 lb

NOTE

Refer to Section 5 (Performance) for maximum weight as limited by performance.

2.13 CENTER OF GRAVITY LIMITS

Weight Pounds	Forward Limit Inches Aft of Datum	Rearward Limit Inches Aft of Datum
2800	84.0	93.0
3400	85.0	93.0
3800	89.0	93.0

NOTES

Straight line variation between points given.

The datum used is 78.4 inches ahead of the wing leading edge at wing station 106.

It is the responsibility of the airplane owner and the pilot to ensure that the airplane is properly loaded. See Section 6 (Weight and Balance) for proper loading instructions.

2.15 MANEUVER LIMITS

All intentional acrobatic maneuvers (including spins) are prohibited. Avoid abrupt maneuvers.

2.17 FLIGHT LOAD FACTORS

(a) Positive Load Factor (Maximum)	
(1) Flaps Up	3.8 G
(2) Flaps Down	2.0 G
(b) Negative Load Factor (Maximum)	No inverted maneuvers approved

2.19 TYPES OF OPERATION

The airplane is approved for the following operations when equipped in accordance with FAR 91 or FAR 135.

- (a) Day V.F.R.
- (b) Night V.F.R.
- (c) Day I.F.R.
- (d) Night I.F.R.
- (e) Non Icing

2.21 FUEL LIMITATIONS

- (a) Minimum Aviation Fuel Grade 100LL or 100
- (b) Total Capacity 110 U.S. GAL.
- (c) Unusable Fuel 2 U.S. GAL.

The unusable fuel for this airplane has been determined as 1.0 gallon in each nacelle in critical flight attitudes.

- (d) Usable Fuel 108 U.S. GAL.

The usable fuel in this airplane has been determined as 54 gallons in each nacelle or a total of 108 gallons.

2.23 MAXIMUM SEATING CONFIGURATION

The maximum seating capacity is 4 persons.

2.25 GYRO SUCTION LIMITS

The operating limits for the suction system are 4.8 to 5.2 inches of mercury for all operations as indicated by the gyro suction gauge.

2.27 PLACARDS

In full view of the pilot:

The markings and placards installed in this airplane contain operating limitations which must be complied with when operating this airplane in the normal category. Other operating limitations which must be complied with when operating this airplane in this category are contained in the airplane flight manual. No acrobatic maneuvers, including spins, approved.

This aircraft approved for V.F.R., I.F.R., day and night non-icing flight when equipped in accordance with FAR 91 or FAR 135.

2.27 PLACARDS (Continued)

In full view of the pilot:

ONE ENGINE INOPERATIVE
AIR MINIMUM CONTROL SPEED 56 KIAS

In full view of the pilot:

ONE ENGINE INOPERATIVE STALLS
NOT RECOMMENDED. CAN CAUSE 300
FT. LOSS OF ALTITUDE AND 30° PITCH
ANGLE.

In full view of the pilot:

WARNING - TURN OFF STROBE LIGHTS
WHEN IN CLOSE PROXIMITY TO
GROUND, OR DURING FLIGHT
THROUGH CLOUD, FOG OR HAZE.

On instrument panel in full view of the pilot:

V_A 135 AT 3800 LBS
(SEE P.O.H.)
V_{Lo} 140 DN, 109 UP
V_{LE} 140 MAX.
DEMO. X-WIND 17 KTS

In full view of the pilot and passengers: (S/N 4496014 and up)

NO SMOKING

2.27 PLACARDS (Continued)

On the landing gear warning mute switch:

GEAR
WARN
MUTE

In full view of the pilot when the oil cooler winterization kit is installed:

OIL COOLER WINTERIZATION PLATE
TO BE REMOVED WHEN AMBIENT
TEMPERATURE EXCEEDS 50°F.

On storm window:

DO NOT OPEN ABOVE 129 KIAS

On the vertical window post between the first and second left side windows and close to the Emergency Exit release handle:

EMERGENCY EXIT
REMOVE COVER PANEL
PULL HANDLE FORWARD
PUSH WINDOW OUT

Near emergency gear release:

EMERGENCY GEAR EXTENSION
PULL TO RELEASE. SEE AFM
BEFORE RE-ENGAGEMENT

Near gear selector switch:

GEAR UP	109 KIAS MAX.
DOWN	140 KIAS MAX.

2.27 PLACARDS (Continued)

Adjacent to upper door latch:

ENGAGE LATCH BEFORE FLIGHT

On inside of baggage compartment door:

BAGGAGE MAX 200 LBS

Adjacent to fuel tank filler caps:

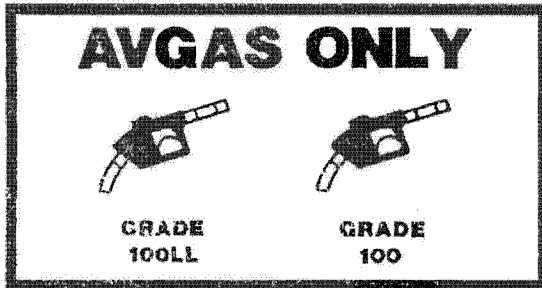

TABLE OF CONTENTS
SECTION 3
EMERGENCY PROCEDURES

Paragraph No.	Page No.
3.1 General	3-1
3.3 Airspeeds for Safe Operations	3-2
3.5 Emergency Procedures Checklist.....	3-2
3.5a Engine Inoperative Procedures (3.9).....	3-2
Identifying Dead Engine and Verifying Power Loss (3.9a).....	3-2
Engine Securing Procedure (Feathering Procedure) (3.9b)	3-2
Engine Failure During Takeoff (Speed Below 75 KIAS or Gear Down)(3.9c).....	3-3
Engine Failure During Takeoff (Speed Above 75 KIAS) (3.9d).....	3-3
Engine Failure During Climb (3.9e).....	3-5
Engine Failure During Flight (Speed Below V_{MCA}) (3.9f).....	3-5
Engine Failure During Flight (Speed Above V_{MCA}) (3.9g)	3-6
One Engine Inoperative Landing (3.9h).....	3-7
One Engine Inoperative Go-Around (3.9i).....	3-8

TABLE OF CONTENTS
SECTION 3
EMERGENCY PROCEDURES

Paragraph No.	Page No.
3.5b Air Starting Procedure (3.11).....	3-8
Unfeathering Procedure/ Unfeathering Accumulator Functioning (3.11a)	3-8
Unfeathering Procedure/ Starter Assisted (3.11b)	3-9
3.5c Engine Roughness (3.13)	3-10
3.5d Engine Overheat (3.15)	3-10
3.5e Loss of Oil Pressure (3.17).....	3-10
3.5f Engine Fire (3.19)	3-11
Engine Fire During Start (3.19a).....	3-11
Engine Fire In Flight (3. 19b)	3-11
3.5g Electrical Fire (3.21)	3-12
3.5h Fuel Management During One-Engine Inoperative Operation (3.23)	3-14
3.5i Engine-Driven Fuel Pump Failure (3.25)	3-14
3.5j Landing Gear Unsafe Warnings (3.27).....	3-14
3.5k Landing Gear Malfunctions (3.29)	3-15
3.5m Gyro Suction Failures (3.31)	3-15

TABLE OF CONTENTS
SECTION 3
EMERGENCY PROCEDURES

Paragraph No.	Page No.
3.5n Electrical Failures (3.33).....	3-16
Single Alternator Failure (3.33a)	3-16
Dual Alternator Failure (3.33b).....	3-17
3.5o Spin Recovery (3.35)	3-18
3.5p Open Door (3.37)	3-19
3.5q Propeller Overspeed (3.39)	3-19
3.5r Emergency Exit (3.41)	3-19
3.7 Amplified Emergency Procedures (General)	3-21
3.9 Engine Inoperative Procedures (3.5).....	3-21
3.9a Identifying Dead Engine and Verifying Power Loss (3.5a)	3-21
3.9b Engine Securing Procedure (Feathering Procedure) (3.5a).....	3-21
3.9c Engine Failure During Takeoff (Speed Below 75 KIAS or Gear Down) (3.5a)	3-22
3.9d Engine Failure During Takeoff (Speed Above 75 KIAS) (3.5a).....	3-22
3.9e Engine Failure During Climb (3.5a).....	3-24
3.9f Engine Failure During Flight (Speed Below VMCA) (3.5a).....	3-25

TABLE OF CONTENTS
SECTION 3
EMERGENCY PROCEDURES

Paragraph No.	Page No.
3.9g Engine Failure During Flight (Speed Above VMCA) (3.5a)	3-25
3.9h One Engine Inoperative Landing (3.5a)	3-26
3.9i One Engine Inoperative Go-Around (3.5a)	3-26
3.9j Summary of Factors Affecting Single Engine Operations	3-27
3.11 Air Starting Procedure (3.5b)	3-28
3.13 Engine Roughness (3.5c)	3-29
3.15 Engine Overheat (3.5d)	3-30
3.17 Loss of Oil Pressure (3.5c)	3-30
3.19 Engine Fire (3.5f)	3-30
3.21 Electrical Fire (3.5g)	3-31
3.23 Fuel Management During One Engine Inoperative Operation (3.5h)	3-33
3.25 Engine Driven Fuel Pump Failure (3.5i)	3-34
3.27 Landing Gear Unsafe Warnings (3.5j)	3-34
3.29 Landing Gear Malfunctions (3.5k)	3-35
3.30 Gear-Up Emergency Landing	3-35
3.31 Gyro Suction Failures (3.5m)	3-35

TABLE OF CONTENTS
SECTION 3
EMERGENCY PROCEDURES

Paragraph No.	Page No.
3.33 Electrical Failures (3.5n).....	3-36
3.35 Spin Recovery (Intentional Spins Prohibited) (3.5o).....	3-37
3.37 Open Door (Entry Door Only) (3.5p)	3-37
3.39 Propeller Overspeed (3.5q)	3-38
3.41 Emergency Exit (3.5r).....	3-38

THIS PAGE INTENTIONALLY LEFT BLANK

**SECTION 3
EMERGENCY PROCEDURES****3.1 GENERAL**

This section provides the recommended procedures for coping with various emergency or critical situations. All of the emergency procedures required by the FAA as well as those necessary for operation of the airplane, as determined by its operating and design features, are presented.

Emergency procedures associated with optional systems and equipment which require handbook supplements are presented in Section 9, Supplements.

This section is divided into two basic parts. The first part contains the emergency procedures checklists. These checklists supply an immediate action sequence to be followed during critical situations with little emphasis on the operation of the systems. The numbers located in parentheses after each checklist heading indicate where the corresponding paragraph in the amplified procedures can be found.

The second part of the section provides amplified emergency procedures corresponding to the emergency procedures checklist items. These amplified emergency procedures contain additional information to provide the pilot with a more complete description of the procedures so they may be more easily understood. The numbers located in parentheses after each paragraph heading indicates the corresponding checklist paragraph.

Pilots must familiarize themselves with the procedures given in this section and must be prepared to take the appropriate action should any emergency situation arise. The procedures are offered as a course of action for coping with the particular situation or condition described. They are not a substitute for sound judgement and common sense.

Most basic emergency procedures are a normal part of pilot training. The information presented in this section is not intended to replace this training. This information is intended to provide a source of reference for the procedures which are applicable to this airplane. The pilot should review standard emergency procedures periodically to remain proficient in them.

3.3 AIRSPEEDS FOR SAFE OPERATIONS

One engine inoperative air minimum control	56 KIAS
One engine inoperative best rate of climb	88 KIAS
One engine inoperative best angle of climb	82 KIAS
Maneuvering (3800 lb)	135 KIAS
Never exceed.....	202 KIAS

3.5 EMERGENCY PROCEDURES CHECKLIST

3.5a Engine Inoperative Procedures (3.9)

**IDENTIFYING DEAD ENGINE AND VERIFYING POWER LOSS
(3.9a)**

Loss of thrust.

Nose of aircraft will yaw in direction of dead engine.

Rudder pedal force will be required in the direction away from the dead engine to maintain straight flight.

**ENGINE SECURING PROCEDURE (FEATHERING PROCEDURE)
(3.9b)**

Throttle	RETARD TO VERIFY
Propeller.....	FEATHER (950 RPM Min.)
Mixture	IDLE CUT-OFF
Cowl Flap.....	CLOSE
Alternator.....	OFF
Magneto Switches.....	OFF
Electric fuel pump.....	OFF
Fuel selector.....	OFF
Electrical load	REDUCE
Crossfeed.....	IF REQUIRED

3.5a Engine Inoperative Procedures (Continued)

ENGINE FAILURE DURING TAKEOFF (SPEED BELOW 75 KIAS OR GEAR DOWN) (3.9c)

ThrottlesIMMEDIATELY CLOSE
 Brakes (or land and brake).....AS REQUIRED
 Stop straight ahead

If insufficient runway remains for a complete stop:

Mixtures.....IDLE CUTOFF
 Fuel SelectorsOFF
 Magneto Switches.....OFF
 Battery Master Switch.....OFF
 Maintain directional control, maneuvering to avoid obstacles if necessary.

ENGINE FAILURE DURING TAKEOFF (SPEED ABOVE 75 KIAS) (3.9d)

If sufficient runway remains for a complete stop:

Directional ControlMAINTAIN
 ThrottlesIMMEDIATELY CLOSE
 Land straight ahead
 BrakesAS REQUIRED

3.5a Engine Inoperative Procedures (Continued)

ENGINE FAILURE DURING TAKEOFF (SPEED ABOVE 75 KIAS)
(3.9d) (Continued)

If gear is in transit or up and the decision is made to continue:

WARNING

In many combinations of aircraft weight, configuration, ambient conditions and speed, negative climb performance may result. Refer to Climb Performance chart- One Engine Operating - Gear Up, Figure 5-19.

Mixture controls	FULL FORWARD
Propeller controls.....	FULL FORWARD
Throttle controls	FULL FORWARD
Flaps.....	FULL UP
Landing Gear Selector.....	CHECK UP
Inoperative Engine.....	IDENTIFY and VERIFY
Throttle (Inop. Engine).....	CLOSE
Propeller (Inop. Engine).....	FEATHER
Mixture (Inop. Engine).....	IDLE CUT-OFF
Establish Bank	2° to 3° INTO OPERATIVE ENGINE
Climb Speed	88 KIAS
Trim	ADJUST TO 2° to 3° BANK TOWARD OPERATIVE ENGINE WITH APPROXIMATELY 1/2 BALL SLIP INDICATED ON THE TURN AND BANK INDICATOR
Cowl Flap (Inop. Engine).....	CLOSE
Alternator Switch (Inop. Engine)	OFF
Magneto Switches (Inop. Engine)	OFF
Electric Fuel Pump (Inop. Engine).....	OFF
Fuel Selector (Inop. Engine).....	OFF

Land as soon as practical at the nearest suitable airport.

3.5a Engine Inoperative Procedures (Continued)

ENGINE FAILURE DURING CLIMB (3.9e)

Airspeed	MAINTAIN 88 KIAS
Directional Control	MAINTAIN
Power	MAX. CONTINUOUS
Inoperative Engine	IDENTIFY and VERIFY
Inoperative Engine	Complete Engine Securing Procedure
Trim	ADJUST TO 2° to 3° BANK TOWARD OPERATIVE ENGINE WITH APPROXIMATELY 1/2 BALL SLIP INDICATED ON THE TURN AND BANK INDICATOR
Cowl Flap (Operative Engine).....	AS REQUIRED
Land as soon as practical at the nearest suitable airport.	

ENGINE FAILURE DURING FLIGHT (SPEED BELOW V_{MCA}) (3.9f)

Rudder	APPLY AGAINST YAW
Throttles.....	RETARD TO STOP TURN
Pitch Attitude	LOWER NOSE TO ACCELERATE ABOVE V _{MCA} (56 KIAS)
Operative Engine	INCREASE POWER AS AIRSPEED INCREASES ABOVE V _{MCA} (56 KIAS)

If altitude permits, a restart may be attempted.

If restart fails or if altitude does not permit restart:

Inoperative Engine.....	SECURE
Trim	ADJUST TO 2° to 3° BANK TOWARD OPERATIVE ENGINE WITH APPROXIMATELY 1/2 BALL SLIP INDICATED ON THE TURN AND BANK INDICATOR
Cowl Flap (Operative Engine).....	AS REQUIRED

3.5a Engine Inoperative Procedures (Continued)

**ENGINE FAILURE DURING FLIGHT (SPEED ABOVE V_{MCA})
(3.9g)**

Inoperative Engine.....IDENTIFY
Operative Engine.....ADJUST POWER AS REQUIRED
AirspeedATTAIN AND MAINTAIN
AT LEAST 88 KIAS

Before securing inop. engine:

Electric Fuel Pump.....ON
Fuel Quantity.....CHECK
Oil Pressure and TemperatureCHECK
Magneto SwitchesCHECK
Air Start.....ATTEMPT

If engine does not start, complete Engine Securing Procedure.

Power (Operative Engine)AS REQUIRED
Fuel Quantity (Operative Engine Tank)SUFFICIENT
Electric Fuel Pump (Operative Engine).....AS REQUIRED
Cowl Flap (Operative Engine).....AS REQUIRED
TrimADJUST TO 2° to 3° BANK
TOWARD OPERATIVE ENGINE
WITH APPROXIMATELY 1/2
BALL SLIP INDICATED ON
THE TURN AND BANK INDICATOR
Electrical LoadDECREASE TO MIN. REQUIRED
Land as soon as practical at the nearest suitable airport.

3.5a Engine Inoperative Procedures (Continued)

ONE ENGINE INOPERATIVE LANDING (3.9h)

Inoperative Engine.....	ENGINE SECURING PROCEDURE COMPLETE
Seat Belts/Harnesses.....	SECURE
Fuel Selector (Operative Engine).....	ON
Mixture (Operative Engine).....	FULL RICH
Propeller Control (Operative Engine).....	FULL FORWARD
Electric Fuel Pump (Operative Engine).....	ON
Cowl Flap (Operative Engine).....	AS REQUIRED
Altitude & Airspeed.....	MAKE NORMAL APPROACH

When Landing is Assured:

Landing Gear	DOWN
Wing Flaps	25° (2nd Notch)
Final Approach Speed	90 KIAS
Power	RETARD SLOWLY AND FLARE AIRPLANE
Trim	AS POWER IS REDUCED (AIRPLANE WILL YAW IN DIRECTION OF OPERATIVE ENGINE)

WARNING

Under many conditions of loading and density altitude a go-around may be impossible and in any event the sudden application of power during one engine inoperative operation makes control of the airplane more difficult.

NOTE

A one engine inoperative go-around should be avoided if at all possible.

3.5a Engine Inoperative Procedures (Continued)

ONE ENGINE INOPERATIVE GO-AROUND (Should be avoided if at all possible) (3.9i)

MixtureFORWARD
Propeller.....FORWARD
Throttle.....SMOOTHLY ADVANCE TO TAKEOFF POWER
Flaps.....RETRACT SLOWLY
Landing Gear.....RETRACT (AFTER POSITIVE CLIMB ACHIEVED)
Airspeed.....88 KIAS
TrimADJUST TO 2° to 3° BANK
TOWARD OPERATIVE ENGINE
WITH APPROXIMATELY 1/2
BALL SLIP INDICATED ON
THE TURN AND BANK INDICATOR
Cowl Flap (Operating Engine).....AS REQUIRED

3.5b Air Starting Procedure (3.11)

UNFEATHERING PROCEDURE/ UNFEATHERING ACCUMULATOR FUNCTIONING (3.11a)

NOTE

With the propeller unfeathering system installed, the propeller will usually windmill automatically when the propeller control is moved forward.

Fuel Selector (Inoperative Engine)ON
Magneto Switches (Inoperative Engine).....ON
Electric Fuel Pump (Inoperative Engine).....ON
MixtureFULL RICH
ThrottleOpen 1/4 inch

3.5b Air Starting Procedure (3.11) (Continued)

Prop ControlFULL FORWARD
 ThrottleReduce power until
 engine is warm
 AlternatorON

NOTE

Starter assist is required if the propeller is not windmilling freely within 5-7 seconds after the propeller control has been moved forward.

When propeller unfeathering occurs, it may be necessary to retard the prop control slightly so as to not overspeed the prop.

UNFEATHERING PROCEDURE/ STARTER ASSISTED (3.11b)

Fuel Selector (Inoperative Engine)ON
 Magneto Switches (Inoperative Engine)ON
 Electric Fuel Pump (Inoperative Engine).....ON
 MixtureFULL RICH
 ThrottleTwo full strokes and
 then open 1/4 inch
 Prop ControlFORWARD TO CRUISE
 Starter.....ENGAGE UNTIL PROP WINDMILLS
 Throttle.....REDUCE POWER until engine is warm

If engine does not start, prime as required.

AlternatorON

3.5c Engine Roughness (3.13)

NOTE

Partial carburetor heat may be worse than no heat at all, since it may melt part of the ice which will refreeze in the intake system. Therefore, when using carburetor heat always use full heat; and, when ice is removed, return the control to the full cold position.

Carburetor HeatON

If roughness continues after one minute:

Carburetor HeatOFF

MixtureADJUST for MAXIMUM
SMOOTHNESS

Electric Fuel PumpON

Engine GaugesCHECK

Magneto SwitchesCHECK

If operation is satisfactory on either magneto, continue on that magneto at reduced power and full RICH mixture to first airport.

3.5d Engine Overheat (3.15)

Cowl FlapsOPEN

MixtureENRICHEN

PowerREDUCE

AirspeedINCREASE

(If altitude permits)

3.5e Loss of Oil Pressure (3.17)

Oil Pressure GaugeVERIFY LOSS &
ENGINE AFFECTED

EngineSECURE per Engine
Securing Procedure

3.5f Engine Fire (3.19)

ENGINE FIRE DURING START (3.19a)

If engine has not started:

- MixtureIDLE CUT-OFF
- ThrottleFULL OPEN
- StarterCONTINUE to Crank Engine

If engine has already started and is running, continue operating to try pulling the fire into the engine.

If fire continues:

- Fuel SelectorsOFF
- Electric Fuel Pumps.....OFF
- Mixtures.....IDLE CUT-OFF
- Throttles.....FULL OPEN
- External Fire Extinguisher.....USE
- AirplaneEVACUATE

NOTES

If fire continues, shut down both engines and evacuate.

If fire is on the ground, it may be possible to taxi away.

ENGINE FIRE IN FLIGHT (3.19b)

- Fuel Selector (Affected Engine)OFF
- Throttle (Affected Engine).....IDLE
- Propeller (Affected Engine)FEATHER
- Mixture (Affected Engine)IDLE CUT-OFF
- Cowl Flap (Affected Engine).....OPEN
- Affected Engine.....COMPLETE Engine Securing Procedure

If fire persists:

- AirspeedINCREASE in attempt to blow out fire

Land as soon as possible at the nearest suitable airport.

3.5g Electrical Fire (3.21)

- Flashlight (at night)LOCATE
- Battery MasterOFF
- Alternator SwitchesOFF
- All Electrical SwitchesOFF
- Radio Master SwitchOFF
- VentsCLOSED (To avoid drafts)
- Cabin HeatOFF

If fire persists, locate and, if practical, extinguish with portable fire extinguisher located on the console just aft of the 2 front seats.

Bus Tie Circuit Breakers

- Both Main BusPULL
- Non-essentialPULL
- Avionics Bus # 1PULL
- Avionics Bus # 2PULL
- L. AlternatorPULL
- R. AlternatorPULL
- All Main Bus Circuit BreakersPULL
- All Avionics Bus Circuit Breakers.....PULL

NOTE

At this point, the pilot must decide if the flight can be safely continued without electrical power. If so, land at the nearest airport and have the electrical system repaired.

If electrical power is required for safe continuation of flight, proceed as follows:

WARNING

The following procedure may reenergize the faulty system. Reset the circuit breakers one at a time. Allow a short time period between the resetting of each breaker. If the faulty system is reinstated, its corresponding circuit breaker must be immediately pulled.

3.5g Electrical Fire (3.21) (Continued)

NOTE

Refer to Power Distribution paragraph on page 7-22 and Figure 7-23 on page 7-23 for electrical power distribution information.

One (1) Main Bus Tie Circuit Breaker	IN
Battery Master.....	ON
L. or R. Alternator Circuit Breaker.....	IN

NOTE

Select the applicable Alternator Field circuit breaker and alternator switch corresponding to the Alternator circuit breaker pressed in.

Alternator Field Circuit Breaker.....	IN
Alternator Switch.....	ON
Main Bus Circuit Breakers	
Electric Tachometer.....	IN
Gear Indicator.....	IN
Avionics Bus #1.....	IN
Avionics Bus #2.....	IN
Radio Master Switch.....	ON
Compass.....	IN
Audio.....	IN
Comm #1.....	IN
Nav #1.....	IN
Vents.....	OPEN (When it is ascertained that fire is completely extinguished)

Land as soon as practical.

WARNING

The landing gear must be lowered using the emergency extension procedure.

3.5h Fuel Management During One Engine Inoperative Operation (3.23)

CRUISING (3.23a)

When using fuel from tank on the same side as the operating engine:

Fuel Selector (Operative Engine).....ON
Fuel Selector (Inoperative Engine).....OFF
Electric Fuel Pumps.....OFF
(except in case of engine driven pump
failure when electric fuel pump on
operating engine side must be used)

When using fuel from tank on the side opposite the operating engine:

Fuel Selector (Operative Engine).....CROSSFEED
Fuel Selector (Inoperative Engine).....OFF
Electric Fuel Pumps.....OFF
(except in case of engine driven pump
failure, electric fuel pump on operating
engine side must be used)

NOTE

Use crossfeed in level cruise flight only.

LANDING (3.23b)

Fuel Selector (Operative Engine).....ON
Fuel Selector (Inoperative Engine).....OFF

3.5i Engine Driven Fuel Pump Failure (3.25)

Electric fuel pump (Affected Engine).....ON

3.5j Landing Gear Unsafe Warnings (3.27)

Red light indicates gear intransit.

Recycle gear if indication continues.

Light will illuminate and gear horn sounds when the gear is not down and locked if throttles are at low settings or wing flaps are in second or third notch position.

3.5k Landing Gear Malfunctions (3.29)

MANUAL EXTENSION OF LANDING GEAR

Check following before extending gear manually:

- Navigation Lights (Daytime).....OFF
- or**
- Day/Night Dimmer Switch (Daytime).....DAY
- Circuit Breakers.....CHECK
- Master Switch.....ON
- Alternators.....CHECK

To extend, proceed as follows:

- AirspeedREDUCE (100 KIAS max.)
- Gear SelectorGEAR DOWN
LOCKED position
- Emerg. Gear Extend Knob.....PULL
- Indicator Lights.....3 GREEN
- Leave emergency gear extension knob out.

3.5m Gyro Suction Failures (3.31)

- VACuum annunciator illuminated.....CHECK SUCTION &
FAILURE SIDE

If Suction Gauge indicates below 4.5 in. Hg.

- RPMINCREASE to 2700
- Altitude.....DESCEND to maintain
4.5 in. Hg.

Use electric turn indicator and other basic flight instruments to monitor Directional Indicator and Attitude Indicator performance.

3.5n Electrical Failures (3.33)

SINGLE ALTERNATOR FAILURE (Zero Amps or ALternator Inop. Light Illuminated - Annunciator Panel). (3.33a)

NOTE

Anytime total tie bus voltage is below approximately 12.5 Vdc, the LO BUS voltage annunciator will illuminate.

- Verify FailureCHECK AMMETERS
Electrical Load (If LO BUS voltage annunciator illuminated).....REDUCE until total load is LESS THAN 60 amps & low bus voltage annunciator EXTINGUISHED
Failed ALTR SwitchOFF
Failed ALTR circuit breaker.....CHECK and RESET AS REQUIRED
Failed ALTR Switch (After OFF at least 1 second).....ON

If power not restored:

- Failed ALTR SwitchOFF
AmmeterMONITOR and MAINTAIN BELOW 60 AMPS

One alternator will supply sufficient current for minimum required avionics and cockpit lighting. Under no circumstances may the total electrical load exceed 60 amps. The cabin recirculation blowers, and position, strobe, and landing lights should not be used unless absolutely necessary.

3.5n Electrical Failures (3.33) (Continued)

DUAL ALTERNATOR FAILURE (Zero Amps Both Ammeters or Alternator Inop. Light Illuminated - Annunciator Panel). (3.33b)

NOTE

Anytime total tie bus voltage is below approximately 12.5 Vdc, the LO BUS voltage annunciator will illuminate.

- Verify failureCHECK AMMETERS
- Electrical Load.....REDUCE to MINIMUM
REQUIRED FOR SAFE FLIGHT
- Alternator SwitchesOFF
- Alternator Circuit BreakersCHECK and RESET
AS REQUIRED
- Alternator Switches (One at a time
after OFF at least 1 second)ON

If only one alternator resets:

- Operating Alternator SwitchON
- Failed Alternator Switch.....OFF
- Electrical Load MAINTAIN LESS than 60 AMPS
- AmmeterMONITOR

If neither alternator resets:

- Both Alternator Switches.....OFF
- Continue flight with reduced electrical load on battery power only.

NOTE

LO BUS voltage annunciator will also be illuminated.

Land as soon as practical. Anticipate complete electrical failure. Duration of battery power available will be dependent on electrical load and battery condition prior to failure.

3.5n Electrical Failures (3.33) (Continued)

WARNING

Compass error may exceed 10 degrees with both alternators inoperative.

NOTE

If the battery is depleted, the landing gear must be lowered using the emergency gear extension procedure. The gear position lights will be inoperative.

3.5o Spin Recovery (Intentional Spins Prohibited) (3.35)

NOTE

Federal Aviation Administration Regulations do not require spin demonstration of multi-engine airplanes; spin tests have not been conducted. The recovery technique presented is based on the best available information.

- ThrottlesRETARD to idle
- RudderFULL OPPOSITE TO
DIRECTION OF SPIN
- Control wheelFULL FORWARD
- AileronsNEUTRAL
- RudderNEUTRALIZE when
rotation stops
- Control wheelSMOOTH BACK PRESSURE
to recover from dive

3.5p Open Door (Entry door only) (3.37)

If both top and side latches are open, the door will trail slightly open and airspeeds will be reduced slightly.

To close the door in flight:

AirspeedSlow to 82 KIAS.

Cabin VentsCLOSE

Storm Window.....OPEN

If Top Latch is OpenLATCH

If Side Latch is OpenPULL on armrest WHILE
MOVING LATCH HANDLE
to latched position

If Both Latches are Open.....LATCH SIDE latch
THEN TOP latch

3.5q Propeller Overspeed (3.39)

Throttle (Affected Engine).....RETARD

Oil pressure (Affected Engine).....CHECK

Prop control (Affected Engine).....FULL DECREASE RPM
THEN SET if any
control available

AirspeedREDUCE

Throttle (Affected Engine)AS REQUIRED to remain
below 2700 rpm

3.5r Emergency Exit (3.41)

Thermoplastic Cover.....REMOVE

Emergency Exit Handle.....PULL FORWARD

Window.....PUSH OUT

THIS PAGE INTENTIONALLY LEFT BLANK

3.7 AMPLIFIED EMERGENCY PROCEDURES (GENERAL)

The following paragraphs are presented to supply additional information for the purpose of providing the pilot with a more complete understanding of the recommended course of action and probable cause of an emergency situation.

3.9 ENGINE INOPERATIVE PROCEDURES (3.5)

3.9a Identifying Dead Engine and Verifying Power Loss (3.5a)

If it is suspected that an engine has lost power, the faulty engine must be identified, and its power loss verified. Rudder pressure required to maintain directional control will be on the side of the operative engine - in short, A DEAD FOOT INDICATES A DEAD ENGINE. Engine gauges like EGT and oil pressure may help confirm the dead engine.

3.9b Engine Securing Procedure (Feathering Procedure) (3.5a)

The engine securing procedure should always be accomplished in a sequential order according to the nature of the engine failure.

Begin the securing procedure by moving the throttle of the inoperative engine towards IDLE. If no changes are noted, the correct identification of the dead engine is confirmed. Move the propeller control to FEATHER (fully aft) before the propeller speed drops below 950 RPM. The propellers can be feathered only while the engine is rotating above 950 RPM. Loss of centrifugal force due to slowing rpm will actuate a stop pin that keeps the propeller from feathering each time the engine is stopped on the ground. One engine inoperative performance will decrease significantly if the propeller of the inoperative engine is not feathered.

The inoperative engine's mixture control should be moved fully aft to the IDLE CUTOFF position. Close its cowl flap to reduce drag. Turn off the alternator switch, magneto switches and the electric fuel pump, move the inoperative engine's fuel selector to the off position. Complete the procedure by reducing the electrical load and considering the use of the fuel crossfeed if the fuel quantity dictates.

NOTE

When an engine is feathered, the OIL, gyro VACuum air, and ALternator annunciator warning lights will remain illuminated.

3.9c Engine Failure During Takeoff (Speed Below 75 KIAS or Gear Down) (3.5a)

Determination of runway length, single engine climb rate, and accelerate/stop distance will aid in determining the best course of action in the event of an engine failure during takeoff. If engine failure occurs during the takeoff roll, the takeoff **MUST** be aborted. If failure occurs after liftoff but before 75 KIAS is achieved or before the gear is retracted, the takeoff should also be aborted. Immediately close the throttles, **land if airborne, apply brakes** as required and stop straight ahead.

If an engine failure occurs below 75 KIAS and there is not adequate runway remaining for landing, deceleration and stop, immediately retard the mixture levers fully aft. Move the fuel selectors to the off position. Turn off the magneto switches followed by the master switch.

During these procedures maintain directional control and if necessary, maneuver to avoid obstacles.

3.9d Engine Failure During Takeoff (Speed Above 75 KIAS) (3.5a)

If engine failure occurs after liftoff with the gear still down and 75 KIAS has been attained the course of action to be taken will depend on the runway remaining and aircraft configuration. Also the pilot's decision must be based on a personal judgement, taking into consideration such factors as obstacles, the type of terrain beyond the runway, altitude and temperature, weight and loading, weather, airplane condition, and the pilot's own proficiency and capability.

WARNING

In many combinations of aircraft weight, configuration, ambient conditions and speed, negative climb performance may result. Refer to Climb Performance -One Engine Operating chart in Section 5.

If adequate runway remains, maintain heading. Close both throttles immediately, **land if airborne, apply brakes** as required and stop straight ahead.

**3.9d Engine Failure During Takeoff (Speed Above 75 KIAS) (3.5a)
(Continued)**

If the runway remaining is inadequate for stopping or the gear is in-transit or up, the pilot must decide whether to abort or to continue the takeoff and climb on a single engine.

If a decision is made to continue the takeoff, the airplane will tend to turn in the direction of the inoperative engine, since one engine will be inoperative and the other will be at maximum power. Rudder pressure force on the side of the operative engine will be necessary to maintain directional control.

Verify the mixture, propeller and throttle controls are fully forward. Remember, keep in mind that the One Engine Inoperative Air Minimum Control speed (VMCA) is 56 KIAS and the One Engine Inoperative Best Rate of Climb speed (VYSE) is 88 KIAS. Verify that the flaps and landing gear are up.

Once the faulty engine is identified and its power loss verified, feather its propeller. Move the mixture to the IDLE CUT-OFF position. Establish a bank of 2° to 3° into the operative engine. Maintain 88 KIAS (V YSE). Trim the aircraft for 2° to 3° bank toward the operative engine with approximately 1/2 ball slip indicated on the turn and bank indicator. Close the cowl flap on the inoperative engine.

After the aircraft is trimmed, the alternator switch, magneto switches, electric fuel pump and fuel selector of the inoperative engine can be turned OFF. Close the cowl flap of the operative engine as much as possible without exceeding engine temperature limits.

Land as soon as practical at the nearest suitable airport.

3.9e Engine Failure During Climb (3.5a)

If engine failure occurs during climb, a minimum airspeed of 88 KIAS (VYSE) should be maintained. Since one engine will be inoperative and the other will be at maximum power, the airplane will have a tendency to turn in the direction of the inoperative engine. Rudder pedal force on the side of the operative engine will be necessary to maintain directional control.

After the faulty engine has been identified and power loss has been verified, complete the Engine Securing Procedure. Continue a straight ahead climb until sufficient altitude (minimum of 1000 feet above ground elevation) is reached to execute the normal Single Engine Landing procedure at the nearest suitable airport.

For maximum climb performance in single engine flight, sideslip must be minimized by banking towards the operating engine 2° to 3° . The ball of the turn and slip indicator will be approximately $1/2$ diameter out of center towards the operating engine for straight flight and should remain so displaced during any maneuvering necessary.

During this climb, engine temperatures must remain at or below specific limits set by the engine manufacturer. Use of full open cowl flaps on the operating engine will ensure that the established temperature limitations will not be exceeded on a day where air temperatures are 100°F at sea level decreasing from that point by 3.5°F per 1000 feet of altitude.

Land as soon as practical at the nearest suitable airport.

3.9f Engine Failure During Flight (Speed Below VMCA)(3.5a)

Should an engine fail during flight at an airspeed below VMCA (56 KIAS) apply rudder towards the operative engine to minimize the yawing motion. The throttles should be retarded to stop the yaw towards the inoperative engine. Lower the nose of the aircraft to accelerate above 56 KIAS and increase the power on the operative engine as the airspeed exceeds 56 KIAS. The airplane should be banked 5° towards the operating engine during this recovery to maximize control effectiveness.

After an airspeed of at least 82 KIAS (VXSE) has been established, an engine restart attempt may be made if altitude permits. If the restart has failed, or altitude does not permit, the engine should be secured. Move the propeller control of the inoperative engine to FEATHER and complete the engine securing procedure. Adjust the trim to a 2° to 3° bank into the operative engine with approximately 1/2 ball slip indicated on the turn and bank indicator. The cowl flap on the operative engine should be adjusted as required to maintain engine temperatures within allowable limits.

3.9g Engine Failure During Flight (Speed Above VMCA)(3.5a)

If an engine fails during flight at an airspeed above VMCA (56 KIAS), begin corrective response by identifying the inoperative engine. The operative engine should be adjusted as required after loss of power has been verified. Attain and maintain an airspeed of at least 88 KIAS (VYSE).

Once the inoperative engine has been identified and the operative engine adjusted properly, an engine restart may be attempted if altitude permits. Prior to securing the inoperative engine, turn on the electric fuel pump. The cause of engine failure may be the failure of the engine driven fuel pump. Check the oil pressure and oil temperature and ensure that the magneto switches are on.

If the engine fails to start, it should be secured using the engine securing procedure. After the inoperative engine has been secured, power should be maintained as required. Check the fuel supply and turn on the emergency fuel pump if necessary. The cowl flap on the operative engine should be adjusted as required to maintain engine temperatures within allowable limits. Adjust the trim for a 2° to 3° bank toward the operating engine with approximately 1/2 ball slip indicated on the turn and bank indicator. The electrical load should be decreased to a required minimum.

Land as soon as practical at the nearest suitable airport.

3.9h One Engine Inoperative Landing (3.5a)

Complete the Engine Securing Procedure. The landing gear should not be extended and the wing flaps should not be lowered until certain of making the field.

Maintain a normal approach keeping in mind that the landing should be made right the first time and that a go-around should be avoided if at all possible.

A final approach speed of 90 KIAS and the use of 25° rather than full wing flaps will place the airplane in the best configuration for a go-around should this be necessary.

WARNING

Under some conditions of loading and density altitude a go-around may be impossible and in any event the sudden application of power during one engine inoperative operation makes control of the airplane more difficult.

3.9i One Engine Inoperative Go-Around (Should be avoided if at all possible) (3.5a)

NOTE

A one engine inoperative go-around should be avoided if at all possible.

To execute a one engine inoperative go-around, verify the mixture and propeller levers are forward, and smoothly advance the throttle to takeoff power. Retract the flaps and landing gear. Maintain airspeed at the one engine inoperative best rate of climb speed of 88 KIAS (V_{YSE}). Set the trim and cowl flaps as required.

3.9j Summary of Factors Affecting Single Engine Operations.

Significant climb performance penalties can result from landing gear, flap, or windmilling propeller drag. These penalties are approximately as listed below:

Landing gear extended/Flaps Up.....	- 250 ft./min.
Flaps extended 25°/Gear Down.....	- 490 ft./min.
Flaps extended fully/Gear Down.....	- 525 ft./min.
Inoperative engine propeller windmilling (Gear and Flaps Up)	-200 ft./min.

WARNING

The propeller on the inoperative engine must be feathered, the landing gear retracted, and the wing flaps retracted for continued flight.

The following general facts should be used as a guide if an engine failure occurs:

1. **Discontinuing a takeoff upon engine failure is advisable under most circumstances. Continuing the takeoff, if engine failure occurs prior to reaching obstacle speed and gear retraction, is not advisable.**
2. Altitude is more valuable to safety after takeoff than is airspeed in excess of the best single-engine climb speed.
3. A windmilling propeller and extended landing gear cause a severe drag penalty and, therefore, **climb or continued level flight is improbable**, depending on weight, altitude and temperature. Prompt retraction of the landing gear, identification of the inoperative engine, and feathering of the propeller is of utmost importance if the takeoff is to be continued.
4. In no case should airspeed be allowed to fall below V_{XSE} (82 KIAS) unless touchdown is imminent even though altitude is lost, since any lesser speed will result in significantly reduced climb performance.

3.9j Summary of Factors Affecting Single Engine Operations.
(Continued)

5. If the requirement for an immediate climb is not present, allow the airplane to accelerate to the single-engine best rate-of-climb airspeed since this speed will always provide the best chance of climb or least altitude loss in a given time.
6. To maximize controllability during recovery following an engine loss near or below VMC, the airplane should be banked approximately 5° into the operative engine and the rudder used to maintain straight flight. This will result in the ball of the turn and slip indicator being displaced 1/2 to 3/4 diameter towards the operating engine.
7. To maximize climb performance after airplane is under control of the pilot and failed engine is secured, the airplane should be trimmed in a 2° to 3° bank towards the operating engine with the rudder used as needed for straight flight. This will result in approximately 1/2 ball displacement towards the operating engine. This ball displacement should be maintained during any necessary maneuvering to maintain best possible climb margins

3.11 AIR STARTING PROCEDURE (3.5b)

3.11a Unfeathering Procedure/ Unfeathering Accumulator Functioning

Move the fuel selector for the inoperative engine to the ON position and check to make sure the electric fuel pump for that engine is ON. The mixture should be set RICH. Open the throttle 1/4 inch and turn ON the magneto switches.

Push the propeller control to the full forward position. If the propeller does not windmill freely within 5 - 7 seconds after the propeller control has been moved full forward, engage the starter for 1 - 2 seconds. The throttle should be set at reduced power until the engine is warm. The alternator switch should be turned ON after restart.

NOTE

When propeller unfeathering occurs, it may be necessary to retard the prop control slightly so as to not overspeed the prop.

3.11 AIR STARTING PROCEDURE (3.5c) (Continued)**3.11b Unfeathering Procedure/ Starter Assisted**

Move the fuel selector for the inoperative engine to the ON position and check to make sure the electric fuel pump for that engine is ON. Push the propeller control forward to the cruise RPM position and the mixture should be set RICH. Push in full throttle twice and then open it 1/4 inch.

Turn ON the magneto switches and engage the starter until the propeller windmills. The throttle should be set at reduced power until the engine is warm. If the engine does not start, prime as necessary. The alternator switch should then be turned ON.

3.13 ENGINE ROUGHNESS (3.5c)

Engine roughness may be caused by induction system icing or ignition problems.

Under certain moist atmospheric conditions at temperatures of -5°C to 20°C, it is possible for ice to form in the induction system, even in summer weather. This is due to the high air velocity through the carburetor venturi and the absorption of heat from this air by vaporization of the fuel.

To avoid this, carburetor preheat is provided to replace the heat lost by vaporization. Carburetor heat should be full on when carburetor ice is encountered. Adjust mixture for maximum smoothness.

If roughness continues for more than one minute, close off all carburetor heat and adjust the mixture for maximum smoothness. The engine will run rough if the mixture is too rich or too lean. Turn ON the electric fuel pump.

Check the engine gauges for abnormal readings. If any gauge readings are abnormal proceed accordingly.

The magneto switches should then be checked one at a time. If operation is satisfactory on either magneto, proceed on that magneto at reduced power with full RICH mixture to a landing at the first available airport.

If roughness persists, prepare for a precautionary landing at pilot's discretion.

3.15 ENGINE OVERHEAT (3.5d)

A steady, rapid rise in oil temperature is a sign of trouble. An abnormally high oil temperature indication may be caused by a low oil level, an obstruction in the oil cooler, damaged or improper baffle seals, a defective gauge, or other causes. Watch the oil pressure gauge for an accompanying loss of pressure.

Excessive cylinder head temperature may parallel excessive oil temperature. In any case, open the cowl flaps, enrich the mixture and / or reduce power, and increase airspeed if altitude permits. If the problem persists, land as soon as practical at an appropriate airport and have the cause investigated.

3.17 LOSS OF OIL PRESSURE (3.5e)

Loss of oil pressure may be either partial or complete. A partial loss of oil pressure usually indicates a malfunction in the oil pressure regulating system, and a landing should be made as soon as possible to investigate the cause and prevent engine damage.

A complete loss of oil pressure indication may signify oil exhaustion or may be the result of a faulty gauge. In either case, continued operation of the engine could result in a serious emergency situation or severe engine damage.

Complete the Engine Securing Procedure (para. 3.5a) on the faulty engine.

If engine oil is depleted, the engine will seize and if feathering is not initiated before 950 RPM is reached, the propeller will not feather

3.19 ENGINE FIRE (3.5f)

3.19a Engine Fire During Start (3.5f)

The first attempt to extinguish the fire is to try to draw the fire back into the engine. If the engine has not started, move the mixture control to idle cut-off and open the throttle. Continue to crank the engine with the starter in an attempt to pull the fire into the engine.

If the engine has already started and is running, continue operating to try to pull the fire into the engine.

3.19 ENGINE FIRE (3.5f) (Continued)**3.19a Engine Fire During Start (3.5f) (Continued)**

In either case (above), if the fire continues longer than a few seconds the fire should be extinguished by the best available external means.

If an external fire extinguishing method is to be applied move the fuel selector valves to OFF and the mixture to idle cut-off.

3.19b Engine Fire In Flight (3.5f)

The possibility of an engine fire in flight is extremely remote. The procedure given below is general and pilot judgment should be the deciding factor for action in such an emergency.

If an engine fire occurs in flight, place the fuel selector of the affected engine in the OFF position and close its throttle. Feather the propeller on the affected engine. Move the mixture control on the affected engine to idle cut-off. The cowl flap on the affected engine should be open. After completion of the Engine Securing Procedure (para. 3.5a) on the affected engine, and if the fire persists, increase airspeed as much as possible in an attempt to blow out the fire.

Land as soon as possible at the nearest suitable airport.

3.21 ELECTRICAL FIRE (3.5g)

The presence of smoke in the cabin or the distinctive odor of smoldering insulation are indications of an electrical fire. The first step in coping with an electrical fire is to turn the master switch OFF. During night flight, be sure that a flashlight is in hand before turning off the master switch. Check for open circuit breakers and turn OFF the Alternator switches, all electrical switches and the Radio Master switch. Proceed to close cabin vents and turn cabin heat OFF.

If the fire persists, locate and, if practical, extinguish with the portable extinguisher located between the front seats, aft of the center console. Then pull all circuit breakers, beginning with the Tie Bus circuit breakers.

NOTE

At this point, the pilot must decide if the flight can be safely continued without electrical power. If so, land at the nearest airport and have the electrical system repaired.

3.21 ELECTRICAL FIRE (3.5g) (Continued)

If electrical power is required for safe continuation of flight, proceed as follows:

WARNING

The following procedure may reenergize the faulty system. Reset the circuit breakers one at a time. Allow a short time period between the resetting of each circuit breaker. If the faulty system is reinstated, its corresponding circuit breaker must be immediately pulled.

NOTE

Refer to Power Distribution paragraph on page 7-22 and Figure 7-23 on page 7-23 for electrical power distribution information.

At this time press IN one MAIN Tie Bus circuit breaker. Turn ON the Battery Master switch and press in either the L or R Alternator circuit breaker applicable to the circuitry remaining operable.

NOTE

Select the applicable Alternator Field circuit breaker and Alternator switch corresponding to the Alternator circuit breaker pressed in.

Press IN the applicable Alternator Field circuit breaker and Alternator switch. Turn ON the Radio Master switch and press in the Main Bus circuit breakers for the noted units required for flight. The other circuit breakers should be left OFF for the remainder of the flight.

Land as soon as practical at the nearest suitable airport.

WARNING

The landing gear must be lowered using the emergency extension procedure.

3.23 FUEL MANAGEMENT DURING ONE ENGINE INOPERATIVE OPERATION (3.5h)

A crossfeed is provided to increase range during one engine inoperative operation. Use crossfeed in level flight only.

3.23a Cruising

When using fuel from the fuel tank on the same side as the operating engine, the fuel selector of the operating engine should be ON and the fuel selector for the inoperative engine should be OFF. The electric fuel pumps should be OFF except in the case of an engine-driven fuel pump failure. If an engine-driven fuel pump has failed, the electric fuel pump on the operating engine side must be ON.

Increased range is available by using fuel from the tank on the opposite side of the operating engine. For this configuration the fuel selector of the operating engine must be on X-FEED (crossfeed) and the fuel selector of the inoperative engine must be OFF. The electric fuel pumps should be OFF. Crossfeed is approved for level cruise flight only.

3.23b Landing

During the landing sequence, the fuel selector of the operating engine must be ON and the fuel selector of the inoperative engine OFF. The electric fuel pump of the operating engine should be ON.

3.25 ENGINE DRIVEN FUEL PUMP FAILURE (3.5i)

Loss of fuel pressure and engine power can be an indication of failure of the engine-driven fuel pump. Should these occur and engine-driven fuel pump failure is suspected, turn ON the electric fuel pump.

CAUTION

If normal engine operation and fuel pressure are not immediately re-established, the electric fuel pump should be turned off. The lack of a fuel pressure indication while on the electric fuel pump could indicate a leak in the fuel system, or fuel exhaustion.

3.27 LANDING GEAR UNSAFE WARNINGS (3.5j)

The red landing gear light (WARN GEAR UNSAFE) will illuminate when the landing gear is in transition between the full up position and the down-and-locked position. The pilot should recycle the landing gear if continued illumination of the light occurs. Additionally, the light will illuminate when the gear warning horn sounds. The gear warning horn will sound at low throttle settings if the gear is not down and locked, and also when wing flaps are in the second or third notch position and the gear is not down and locked.

3.29 LANDING GEAR MALFUNCTIONS (3.5k)

Manual Extension of Landing Gear

Several items should be checked prior to extending the landing gear manually. Check for popped circuit breakers and ensure the master switch is ON. Then check the alternators. If it is daytime, turn OFF the navigation lights or select DAY on the day/night dimmer switch, whichever applies to your aircraft.

To execute a manual extension of the landing gear, power should be reduced to maintain airspeed below 100 KIAS. Place the landing gear selector switch in the GEAR DOWN position and pull the emergency gear extension knob. Check for 3 green indicator lights.

WARNING

If the emergency gear extension knob has been pulled out to lower the gear due to a gear system malfunction, leave the control in its extended position until the airplane has been put on jacks to check the proper function of the landing gear hydraulic and electrical systems.

3.30 GEAR-UP EMERGENCY LANDING

An approach should be made with power at a normal airspeed with the flaps up. The flaps are left up to reduce wing and flap damage. Close the throttles just before touchdown. Turn OFF the master and ignition switches and move the fuel selector valve controls to OFF. Contact to the surface should be made at a minimum airspeed.

3.31 GYRO SUCTION FAILURES (3.5m)

A malfunction of the instrument suction system will be indicated by a reduction of the suction reading on the gauge. A red button annunciator will show in case of a feathered engine or vacuum pump failure.

In the event of a suction system malfunction, (suction lower than 4.5 inches of mercury) increase engine RPM to 2700. Descend to an altitude at which 4.5 inches of mercury suction can be maintained, if possible. The electric turn indicator should be used to monitor the performance of the directional and attitude indicators.

3.33 ELECTRICAL FAILURES (3.5n)

WARNING

Compass error may exceed 10 degrees with both alternators inoperative.

NOTE

If the battery is depleted, the landing gear must be lowered using the emergency extension procedure. The green position lights will be inoperative.

3.33a Single Alternator Failure (Zero Amps or ALternator Light Illuminated - Annunciator Panel) (3.5n)

If one ammeter shows zero output or the ALternator annunciator light is illuminated, reduce electrical loads to a minimum, turn the inoperative alternator switch OFF and check its circuit breaker. Reset if required. After at least one second, turn the ALT switch ON. If the alternator remains inoperative, turn the ALT switch OFF, maintain an electrical load not to exceed 60 amps on the operating alternator and exercise judgment regarding continued flight. The cabin recirculation blowers, and position, strobe, and landing lights should not be used unless absolutely necessary.

3.33b Dual Alternator Failure (Zero Amps Both Ammeters or ALternator Light Illuminated - Annunciator Panel) (3.5n)

If both ammeters show zero output, reduce electrical loads to a minimum and turn both ALT switches OFF. Check both alternator circuit breakers and reset if required. After being OFF at least one second, turn ALT switches ON one at a time while observing the ammeters.

If only one alternator output can be restored, leave the operating ALternator switch ON, turn the faulty ALternator switch OFF, reduce electrical loads to less than 60 amps and monitor the ammeter.

If neither alternator output can be restored, turn both ALT switches OFF. Maintain a minimum electrical load (less than 60 amps) and land as soon as practical. The battery is the only remaining source of electrical power.

3.35 SPIN RECOVERY (INTENTIONAL SPINS PROHIBITED) (3.5o)

NOTE

Federal Aviation Administration Regulations do not require spin demonstration of multi-engine airplanes; therefore, spin tests have not been conducted. The recovery technique presented is based on the best available information.

Intentional spins are prohibited in this airplane. In the event a spin is encountered unintentionally, immediate recovery actions must be taken.

To recover from an unintentional spin, immediately retard the throttles to the idle position. Apply full rudder opposite the direction of the spin rotation and immediately push the control wheel full forward. Keep the ailerons neutral. Maintain the controls in these positions until spin rotation stops, then neutralize the rudder. Recovery from the resultant dive should be with smooth back pressure on the control wheel. No abrupt control movement should be used during recovery from the dive, as the positive limit maneuvering load factor may be exceeded.

3.37 OPEN DOOR (ENTRY DOOR ONLY) (3.5p)

The cabin door is double latched, so the chances of its springing open in flight at both the top and side are remote. However, should you forget the upper latch, or not fully engage the side latch, the door may spring partially open. This will usually happen at takeoff or soon afterward. A partially open door will not affect normal flight characteristics, and a normal landing can be made with the door open.

If both upper and side latches are open, the door will trail slightly open, and airspeed will be reduced slightly.

To close the door in flight, slow the airplane to 82 KIAS, close the cabin vents and open the storm window. If the top latch is open, latch it. If the side latch is open, pull on the armrest while moving the latch handle to the latched position. If both latches are open, close the side latch then the top latch.

3.39 PROPELLER OVERSPEED (3.5q)

Propeller overspeed is usually caused by a malfunction in the propeller governor which allows the propeller blades to rotate to full low pitch.

If propeller overspeed should occur, retard the throttle. The propeller control should be moved to full DECREASE rpm and then set if any control is available. Airspeed should be reduced and the throttle should be used to maintain 2700 RPM.

3.41 EMERGENCY EXIT (3.5r)

The pilot's left side window is an emergency exit. This is to be used when emergency egress becomes necessary on the ground only. The emergency exit release handle is located beneath the thermoplastic cover on the vertical post between the 1st and 2nd left side windows. To exit the aircraft, remove the thermoplastic cover, push the release handle forward and then push the window out. The window then will fall free from the fuselage.

TABLE OF CONTENTS
SECTION 4
NORMAL PROCEDURES

Paragraph No.		Page No.
4.1	General	4-1
4.3	Airspeed for Safe Operation.....	4-2
4.5	Normal Procedures Check List	4-3
4.5a	Preflight Check.....	4-3
4.5b	Before Starting Engine	4-7
4.5c	Engine Start Checklists	4-7
4.5d	Before Taxiing Checklist.....	4-11
4.5e	Taxiing Checklist.....	4-11
4.5f	Ground Check Checklist	4-12
4.5g	Before Takeoff Checklist.....	4-12
4.5h	TakeOff Checklist.....	4-13
4.5i	Climb Checklist.....	4-15
4.5j	Cruise Checklist	4-15
4.5k	Descent Checklist.....	4-15
4.5m	Approach and Landing Checklist.....	4-16

TABLE OF CONTENTS
SECTION 4
NORMAL PROCEDURES

Paragraph No.		Page No.
4.5n	Go-Around Checklist	4-17
4.5o	After Landing Checklist	4-17
4.5p	Stopping Engine Checklist	4-17
4.5q	Mooring Checklist.....	4-18
4.7	Amplified Normal Procedures (General)	4-19
4.9	Preflight Check	4-19
4.11	Before Starting Engine.....	4-23
4.13	Engine Start.....	4-24
4.15	Before Taxiing.....	4-28
4.17	Taxiing.....	4-29
4.19	Ground Check	4-29
4.21	Before Takeoff.....	4-30
4.23	TakeOff.....	4-30
4.25	Climb.....	4-32
4.27	Cruise	4-33
4.29	Descent.....	4-35
4.31	Approach and Landing.....	4-35

TABLE OF CONTENTS
SECTION 4
NORMAL PROCEDURES

Paragraph No.	Page No.
4.33 Go-Around	4-38
4.35 After Landing	4-38
4.37 Stopping Engine	4-38
4.39 Mooring.....	4-38
4.41 Stalls	4-39
4.43 Turbulent Air Operation	4-39
4.45 VsSE - Intentional One Engine Inoperative Speed	4-39
4.47 VMCA - Air Minimum Control Speed	4-40
4.49 Practice One Engine Inoperative Flight	4-41
4.51 Noise Level	4-42

THIS PAGE INTENTIONALLY LEFT BLANK

**SECTION 4
NORMAL PROCEDURES****4.1 GENERAL**

This section provides the normal operating procedures for the PA-44-180, Seminole airplane. All of the normal operating procedures required by the FAA as well as those procedures which have been determined as necessary for the operation of the airplane, as determined by the operating and designed features of the airplane, are presented.

Normal operating procedures associated with optional systems and equipment which require handbook supplements are presented in Section 9, Supplements.

These procedures are provided to supply information on procedures which are not the same for all airplanes and as a source of reference and review. Pilots should familiarize themselves with these procedures to become proficient in the normal operation of the airplane.

This section is divided into two parts. The first part is a short form checklist supplying an action - reaction sequence for normal procedures with little emphasis on the operation of the systems. Numbers in parentheses after each checklist section indicate the paragraph where the corresponding amplified procedures can be found.

The second part of this section contains the amplified normal procedures which provide detailed information and explanations of the procedures and how to perform them. This portion of the section is not intended for use as an inflight reference due to the lengthy explanation. The short form checklists should be used on the ground and in flight. Numbers in parentheses after each paragraph title indicate where the corresponding checklist can be found.

4.3 AIRSPEEDS FOR SAFE OPERATIONS

The following airspeeds are those which are significant to the safe operation of the airplane. These figures are for standard airplanes flown at gross weight under standard conditions at sea level.

Performance for a specific airplane may vary from published figures depending upon the equipment installed, the condition of the engine, airplane and equipment, atmospheric conditions and piloting technique.

(a) Best Rate of Climb Speed	88 KIAS
(b) Best Angle of Climb Speed	82 KIAS
(c) Turbulent Air Operating Speed (See Subsection 2.3)	135 KIAS
(d) Maximum Flap Speed	111 KIAS
(e) Landing Final Approach Speed (Flaps 40 degrees) Short Field Effort	75 KIAS
(f) Intentional One Engine Inoperative Speed	82 KIAS
(g) Maximum Demonstrated Crosswind Velocity	17 KIAS

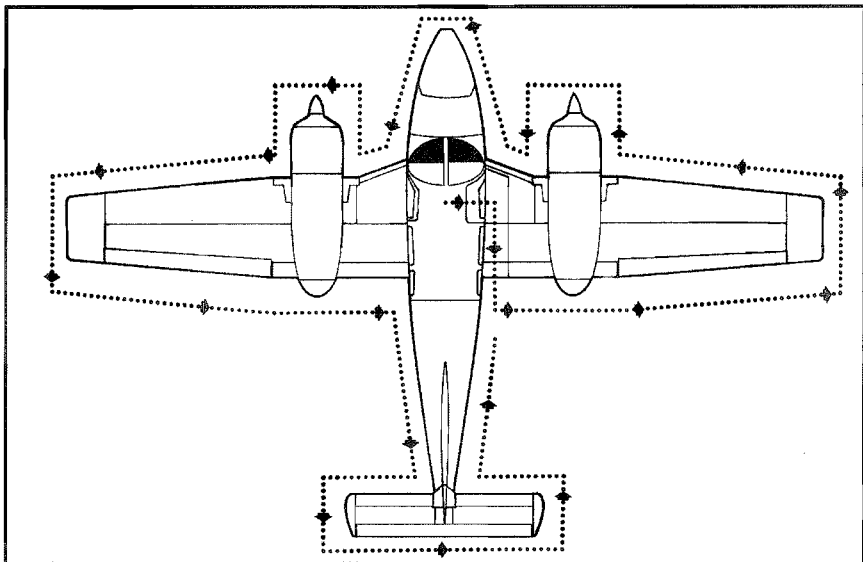

WALK-AROUND

Figure 4-1

4.5 NORMAL PROCEDURES CHECKLIST

4.5a Preflight Checklists (4.9)

COCKPIT (4.9a)

Control Wheel	release restraints
Static System	DRAIN
Alternate Static Source	NORMAL
Magneto Switches	OFF
Parking Brake	SET
Fuel Pump Switches	OFF
Gear Selector	DOWN
Throttles	IDLE
Mixture Controls	IDLE CUT-OFF
Cowl Flaps	OPEN
Flight Controls	PROPER OPERATION
Stabilator & Rudder Trim	NEUTRAL
Fuel Selectors	ON
Radio Master Switch	OFF
All Electrical Switches	OFF

4.5a Preflight Checklists (4.9) (Continued)

COCKPIT (4.9a)

Battery Master Switch.....ON
Fuel GaugesCHECK QUANTITY
Annunciator PanelPRESS TO TEST
Landing Gear Lights.....3 GREEN
Battery Master SwitchOFF
Emergency ExitCHECK
Flaps.....EXTEND
Windows.....check CLEAN
Required Paperscheck ON BOARD
POH.....check ON BOARD
BaggageSTOW PROPERLY - SECURE

RIGHT WING (4.9b)

Fuel Sump Drains.....DRAIN
Surface ConditionCLEAR of ICE, FROST & SNOW
Flap and Hinges.....CHECK
Aileron, Hinges & Freedom of Movement.....CHECK
Static Wicks.....CHECK
Wing Tip and Lights.....CHECK
Scupper DrainCLEAR
Fuel Tank VentCLEAR
Tie DownREMOVE
Nacelle Fuel Filler Cap.....CHECK & SECURE
Engine Oil & Cap.....CHECK & SECURE
Propeller & Spinner.....CHECK
Air InletsCLEAR
Cowl Flap AreaCHECK
Main Gear Strut.....PROPER INFLATION
(2.60 ±0.25 in.)
Main Wheel Tire.....CHECK
Brake, Block & DiscCHECK
ChockREMOVE

4.5a Preflight Checklists (4.9) (Continued)**NOSE SECTION (4.9c)**

General Condition	CHECK
Windshield	CLEAN
Battery Vents	CLEAR
Landing Lights	CHECK
Heater Air Inlet	CLEAR
Chock	REMOVE
Nose Gear Strut	PROPER INFLATION (2.70 +/- 0.25 in.)
Nose Wheel Tire	CHECK

LEFT WING (4.9d)

Surface Condition	CLEAR of ICE, FROST & SNOW
Main Gear Strut	PROPER INFLATION (2.60 +/- 0.25 in.)
Main Wheel Tire	CHECK
Brake, Block & Disc	CHECK
Chock	REMOVE
Cowl Flap Area	CHECK
Nacelle Fuel Filler Cap	CHECK & SECURE
Engine Oil & Cap	CHECK & SECURE
Propeller & Spinner	CHECK
Air Inlets	CLEAR
Scupper Drain	CLEAR
Fuel Tank Vent	CLEAR
Tie Down	REMOVE
Stall Warning Vanes	CHECK
Pitot/ Static Head	CLEAR
Wing Tip and Lights	CHECK
Aileron, Hinges & Freedom of Movement	CHECK
Flap and Hinges	CHECK
Static Wicks	CHECK

4.5a Preflight Checklists (4.9) (Continued)

FUSELAGE (LEFT SIDE) (4.9e)

General ConditionCHECK
Emergency ExitCHECK
Antennas.....CHECK
Fresh Air Inlet.....CLEAR

EMPENNAGE (4.9f)

Surface ConditionCLEAR of ICE, FROST & SNOW
Stabilator, Trim Tab & Freedom of MovementCHECK
Rudder, Trim Tab & Freedom of Movement.....CHECK
Static Wicks.....CHECK
Tie Down.....REMOVE

FUSELAGE (RIGHT SIDE) (4.9g)

General ConditionCHECK
Baggage Door.....SECURE AND LOCKED
Cabin DoorCHECK

MISCELLANEOUS (4.9h)

Flaps.....RETRACT
Battery Master Switch.....ON
Interior Lighting (Night Flight).....ON & CHECK

CAUTION

Care should be taken when an operational check of the heated pitot head is being performed. The unit becomes very hot. Ground operation should be limited to 3 minutes maximum to avoid damaging the heating elements.

Pitot Heat Switch.....ON
Exterior Lighting Switches.....ON & CHECK
Pitot/Static Head.....CHECK - WARM
All Lighting Switches.....OFF
Pitot Heat Switch.....OFF
Battery Master SwitchOFF
PassengersBOARD

4.5b Before Starting Engine Checklists (4.11)

BEFORE STARTING ENGINE (4.11)

Preflight Check	COMPLETED
Flight Planning	COMPLETED
Cabin Door	CLOSE & SECURE
Seats	ADJUSTED & LOCKED
Seatbelts and Harness	FASTEN/ADJUST
	CHECK INERTIA REEL
Alternators	ON
Parking Brake	SET
Gear Selector	GEAR DOWN
Throttles	IDLE
Propeller Controls	FULL FORWARD
Mixture	IDLE CUT-OFF
Friction Handle	AS DESIRED
Carburetor Heat Controls	OFF
Cowl Flaps	OPEN
Trim	SET
Fuel Selectors	ON
Radio Master Switch	OFF
Electrical Switches	OFF
Heater Switch	OFF
Circuit Breakers	CHECK IN

4.5c Engine Start Checklists (4.13)

ENGINE START - GENERAL (4.13)

NOTE

When starting at ambient temperatures +20°F and below, operate first engine started with alternator ON (at max charging rate not to exceed 1500 RPM) for 5 minutes minimum before initiating start on second engine.

4.5c Engine Start Checklists (4.13) (Continued)

NORMAL START - COLD ENGINE (4.13a)

Battery Master Switch.....ON
Gear Lights3 GREEN
Throttles..... 1/4 inch OPEN
Propeller Controls.....FULL FORWARD
Mixtures.....FULL RICH
*Electric Fuel Pump.....ON
*PrimerAS REQUIRED
*Propeller Area.....CLEAR
*Magneto SwitchesON
*Starter.....ENGAGE
*ThrottleADJUST WHEN ENGINE
STARTS TO 1000 RPM
*Oil PressureCHECK

Repeat Above Procedure (*) for Second Engine Start

AmmetersCHECK
Gyro Vacuum.....CHECK

NORMAL START - HOT ENGINE (4.13b)

Battery Master Switch.....ON
Gear Lights3 GREEN
Throttles..... 1/2 inch OPEN
Propeller Controls.....FULL FORWARD
*MixtureFULL RICH
*Electric Fuel Pump.....ON
*Propeller Area.....CLEAR
*Magneto SwitchesON
*Starter.....ENGAGE
*ThrottleADJUST to LOW RPM
*Oil PressureCHECK

Repeat Above Procedure (*) for Second Engine Start

AmmetersCHECK
Gyro Vacuum.....CHECK

4.5c Engine Start Checklists (4.13) (Continued)

ENGINE START - COLD WEATHER (BELOW 10°F) (4.13c)*CAUTION*

Ensure magneto and master switches are OFF and mixture controls are in idle cut-off before turning propeller manually.

If available, preheat should be considered. Rotate each propeller through 10 blades manually during preflight inspection.

Battery Master Switch	OFF
Magneto Switches.....	OFF
External Power	CONNECTED (SEE STARTING ENGINES WITH EXTERNAL POWER)
Electric Fuel Pump.....	ON
Mixture	FULL RICH
Propeller Control	FULL FORWARD
Throttle	1/4 inch OPEN
Primer	AS REQUIRED
Propeller Area	CLEAR
Magneto Switches	ON
Starter.....	ENGAGE
Oil Pressure	CHECK

If engine does not start, add prime and repeat above. When engine fires, prime as required until engine is running smoothly.

Repeat above procedure for second engine start

Throttles	LOWEST POSSIBLE RPM
-----------------	---------------------

WARNING

Shut down the right engine when it is warmed prior to disconnecting the external power plug.

External Power Plug	DISCONNECT
Battery Master Switch.....	ON
Alternators.....	ON

4.5c Engine Start Checklists (4.13) (Continued)

Ammeter (Operating Engine).....CHECK
Right Engine.....NORMAL RESTART
Gyro Vacuum.....CHECK

ENGINE START WHEN FLOODED (4.13d)

MixtureIDLE CUT-OFF
Propeller ControlFULL FORWARD
ThrottleOPEN FULL
Electric Fuel PumpOFF
Battery Master Switch.....ON
Propeller AreaCLEAR
Magneto SwitchesON
Starter.....ENGAGE
Mixture.....ADVANCE
ThrottleRETARD
Oil PressureCHECK
AmmetersCHECK
Gyro Vacuum.....CHECK

ENGINE START WITH EXTERNAL POWER SOURCE (4.13e)

Battery Master SwitchOFF
All Electrical EquipmentOFF
External Power Plug.....INSERT in RECEPTACLE

Proceed with normal start.

Oil PressureCHECK
ThrottlesLOWEST POSSIBLE RPM

WARNING

Shutdown the right engine when it is warmed
prior to disconnecting the external power plug.

External Power Plug.....DISCONNECT from RECEPTACLE

4.5c Engine Start Checklists (4.13) (Continued)

Battery Master Switch.....ON
 Alternators.....ON
 Ammeter (Operating Engine).....CHECK
 Right EngineRESTART
 Gyro Vacuum.....CHECK

4.5d Warm-Up Checklist (4.15)**WARM-UP (4.15a)**

Throttles.....1000 to 1200 RPM

BEFORE TAXIING (4.15b)

External Power Source UnitREMOVE
 Battery Master Switch.....ON
 Gyros.....SET
 Altimeter and Clock.....SET
 Radio Master Switch.....ON
 LightsAS REQUIRED
 HeaterAS DESIRED
 Radios.....CHECK & SET
 AutopilotTEST & OFF
 Electric Trim.....CHECK
 Passenger BriefingCOMPLETE
 Parking BrakeRELEASE

4.5e Taxiing Checklist (4.17)**TAXIING (4.17)**

Taxi Area.....CLEAR
 Throttles.....APPLY SLOWLY
 BrakesCHECK
 Steering.....CHECK
 InstrumentsCHECK
 Fuel SelectorsON, CHECK CROSSFEED

4.5f Ground Check Checklist (4.19)

GROUND CHECK (4.19)

Parking BrakeSET
Mixtures.....FULL RICH
Propeller Controls.....FULL FORWARD
Engine Instruments.....CHECK
Throttles.....1500 RPM
Propeller Controls (Max. Drop - 500 RPM).....FEATHER - CHECK
Throttles.....2000 RPM
Magnetos (Max. Drop - 175 RPM:
 Max. Diff. - 50 RPM).....CHECK
Propeller Controls (Max. Drop - 300 RPM).....EXERCISE
Carburetor HeatCHECK
Alternator OutputCHECK
Annunciator Panel LightsOUT
Gyro Vacuum Gauge.....4.8 to 5.2 IN Hg
Throttles (500 to 600 RPM).....IDLE - CHECK
Throttles.....1000 RPM
Friction HandleSET

4.5g Before Takeoff Checklist (4.21)

BEFORE TAKEOFF (4.21)

ControlsCHECK
Flight Instruments.....CHECK
Engine Instruments.....CHECK
Fuel Quantity.....SUFFICIENT
Electric Fuel PumpsON
Mixtures.....FULL FORWARD
Fuel SelectorsON
Stabilator and Rudder Trims.....SET
Engine RunupCOMPLETE
Autopilot.....OFF
Pitot HeatAS REQUIRED
Carburetor HeatOFF

4.5g Before Takeoff Checklist (4.21) (Continued)

Cowl Flaps.....	OPEN
Transponder.....	AS REQUIRED
Flaps.....	CHECK & SET
Warning Lights.....	CHECK
Door.....	LATCHED
Parking Brake.....	RELEASE

4.5h Takeoff Checklist (4.23)*CAUTION*

Fast taxi turns immediately prior to takeoff should be avoided to prevent unporting fuel feed lines.

NOTE

Adjust mixture prior to takeoff at high elevations. Do not overheat engines. Adjust mixture only enough to obtain smooth engine operation.

NORMAL TAKEOFF (4.23a)

Flaps.....	0° to 10°
Stabilator and Rudder Trim.....	CHECK SET
Power.....	2700 RPM, FULL THROTTLE
Rotate Speed.....	75 KIAS
Climb Speed.....	88 KIAS
Gear.....	UP
Flaps.....	UP

4.5h Takeoff Checklist (4.23) (Continued)

0° FLAP, SHORT FIELD PERFORMANCE TAKEOFF (4.23b)

Flaps.....UP
Stabilator and Rudder Trim.....CHECK SET
Brakes.....HOLD
Power.....2700 RPM, FULL THROTTLE
Mixture.....FULL RICH (or SET for ALTITUDE)
Brakes.....RELEASE
Rotate Speed.....70 KIAS
Obstacle Clearance Speed82 KIAS
Gear.....UP
Climb Speed (past obstacles).....88 KIAS

4.5i Climb Checklist (4.25)

MAXIMUM PERFORMANCE CLIMB (4.25a)

Best Rate (Flaps Up).....	88 KIAS
Best Angle (Flaps Up).....	82 KIAS
Cowl Flaps.....	OPEN
Electric Fuel Pumps.....	ON

CRUISE CLIMB (4.25b)

Mixture.....	FULL RICH
Power.....	75%
Climb Speed.....	105 KIAS
Cowl Flaps.....	As Required
Electric Fuel Pumps.....	ON

4.5j Cruise Checklist (4.27)

CRUISING (4.27)

Reference performance charts and Avco-Lycoming Operator's Manual.

Power.....	SET per Power Setting Chart
Electric Fuel Pumps.....	OFF
Mixture Controls.....	ADJUST
Cowl Flaps.....	As Required

4.5k Descent Checklist (4.29)

DESCENT (4.29)

Mixture Controls.....	ADJUST with Descent
Throttles.....	As Required
Cowl Flaps.....	As Required

4.5m Approach and Landing Checklist (4.31)**APPROACH AND LANDING (4.31)**

Seat Backs	ERECT
Seat Belts, Harnesses	ADJUSTED
Electric Fuel Pumps	ON
Fuel Selectors	ON
Landing Gear (Below 140 KIAS).....	DOWN
Landing Gear Lights.....	3 GREEN
Nacelle Mirror.....	NOSE GEAR DOWN
Mixture Controls	FULL RICH
Propeller Controls.....	FULL FORWARD
Carburetor Heat Controls.....	AS REQUIRED
Autopilot.....	OFF

NORMAL LANDING (4.31a)

Flaps.....	0° to FULL DOWN
Airspeed (Flaps Up).....	80-90 KIAS
(Flaps Down).....	75-85 KIAS
Trim	AS REQUIRED
Throttles.....	AS REQUIRED
Touchdown.....	MAIN WHEELS
Braking	AS REQUIRED

SHORT FIELD PERFORMANCE LANDING (4.31b)

Flaps (Below 111 KIAS).....	FULL DOWN
Airspeed (At Max. Weight).....	75 KIAS
Trim	AS REQUIRED
Throttles.....	IDLE
Touchdown.....	MAIN WHEELS
Braking	MAXIMUM without SKIDDING

4.5n Go-Around Checklist (4.33)

GO-AROUND (4.33)

- Mixture Controls.....FULL FORWARD
- Propeller Controls.....FULL FORWARD
- Throttle Controls.....FULL FORWARD
- Control WheelBACK PRESSURE TO OBTAIN
 POSITIVE CLIMB ATTITUDE
- Flaps.....RETRACT SLOWLY
- Gear.....UP
- Cowl Flaps.....AS REQUIRED

4.5o After Landing Checklist (4.35)

AFTER LANDING (4.35)

- Clear of runway.
- Flaps.....RETRACT
- Cowl Flaps.....FULL OPEN
- Carburetor Heat Controls.....OFF
- Electric Fuel Pumps.....OFF
- Landing and Taxi Lights.....AS REQUIRED

4.5p Stopping Engine Checklist (4.37)

STOPPING ENGINE (4.37)

- Heater (If ON).....FAN - 2 MIN. THEN OFF
- Radio Master SwitchOFF
- Electrical EquipmentOFF
- Throttles.....IDLE
- Mixtures.....IDLE CUTOFF
- Magneto Switches.....OFF
- Alternator SwitchesOFF
- Panel Lights (At Night)OFF
- Battery MasterOFF

4.5q Mooring Checklist (4.39)

MOORING (4.39)

Parking BrakeSET
Control WheelSECURED with belts
FlapsFULL UP
Wheel ChocksIN PLACE
TiedownsSECURE

4.7 AMPLIFIED NORMAL PROCEDURES (GENERAL)

The following paragraphs are provided to supply detailed information and the explanations of the normal procedures necessary for the safe operation of the airplane.

4.9 PREFLIGHT CHECK (4.5a)

The airplane should be given a thorough preflight and walk-around inspection. The preflight should include a check of the airplane's operational status, computation of weight and C.G. limits, takeoff distance and in-flight performance. A weather briefing should be obtained for the intended flight path, and any other factors relating to a safe flight should be checked before takeoff.

4.9a Cockpit (4.5a)

Upon entering the cockpit, release the seat belts securing the control wheel. Open the static system drain to remove any moisture that has accumulated in the lines. Verify that the alternate static system valve is in the normal position. Ensure that the magneto switches are OFF.

Set the parking brake by first depressing and holding the toe brake pedals and then pulling out the parking brake knob.

Check that the fuel pump switches are in the Off position.

Check that the landing gear selector is in the DOWN position.

The throttles should be at IDLE and the mixture controls should be in IDLE CUT-OFF. Move the cowl flap controls to the full OPEN position.

Check the primary flight controls for proper operation and set the stabilator and rudder trim to neutral. Ensure that both fuel selectors are ON.

Verify the radio master switch and all electrical switches are in the OFF position. Turn battery master switch ON.

Check the fuel quantity gauges for adequate supply of fuel. Check the annunciator lights with the PRESS-TO-TEST button located to the left of the annunciator panel. Check that the three landing gear lights are ON. Turn OFF the battery master switch.

4.9a Cockpit (4.5a) (Continued)

CAUTION

If the emergency exit is unlatched in flight, it may separate and damage the exterior of the airplane.

Check that the emergency exit is in place and securely latched. Extend the flaps for the walk-around inspection. Check the windows for cleanliness. Check that the POH and all required papers are on board. Properly stow any baggage and secure.

4.9b Right Wing (4.5a)

After exiting the cockpit, the first items to check during the walk-around are the fuel sump drains. These drains are located on the right side of the fuselage just forward of the entrance step. Drain and check for water, foreign matter and proper fuel.

Check that the wing surface and control surfaces are clear of ice, frost, snow or other extraneous substances. Check the flap, aileron and hinges for damage and operational interference. Static wicks should be firmly attached and in good condition. Check the wing tip and lights for damage.

Proceeding along the wing, verify that the scupper drain and fuel tank vent located on the underside of the wing, outboard of the nacelle, are clear of obstructions. Remove the tiedown.

Open the fuel cap and visually check the fuel quantity. The quantity should match the indication that was on the fuel quantity gauges. Replace cap securely.

Proceed forward to the engine cowling. Check its general condition; look for oil or fluid leakage and that the cowling is secure. Open the oil access door and check the oil quantity (four to eight quarts). Eight quarts are required for maximum range. Secure the access door.

The propeller and spinner should be checked for detrimental nicks, cracks, or other defects, and the air inlets are clear of obstructions. Move down to the cowl flap area. The cowl flaps should be open and secure.

4.9b Right Wing (4.5a) (Continued)

Next, complete a check of the landing gear. Check the main gear strut for proper inflation. There should be 2.60 +/- 0.25 inches of strut exposure under a normal static load. Check for hydraulic leaks. Check the tire for cuts, wear, and proper inflation. Make a visual check of the brake, block and disc. Remove the chock.

4.9c Nose Section (4.5a)

Check the general condition of the nose section. The windshield should be clean, secure and free from cracks or distortion. Next check that the battery vents are clear of obstructions. Check the condition and security of the landing lights. The heater air inlet should be clear of obstructions. Next remove the chock and check the nose gear strut for proper inflation. There should be 2.70 +/- 0.25 inches of strut exposure under a normal static load. Check the tire for cuts, wear, and proper inflation.

4.9d Left Wing (4.5a)

The wing surface should be clear of ice, frost, snow or other extraneous substances. Check the main gear strut for proper inflation. There should be 2.60 +/- 0.25 inches of strut exposure under a normal static load. Check for hydraulic leaks. Check the tire for cuts, wear, and proper inflation. Make a visual check of the brake, block and disc. Remove the chock. Next, check the cowl flap area. The cowl flap should be open and secure.

Proceed to the fuel filler cap. Open the fuel cap and visually check the fuel quantity. The quantity should match the indication that was on the fuel quantity gauges. Replace cap securely.

Next, check the engine cowling. Check its general condition; look for oil or fluid leakage and that the cowling is secure. Open the oil access door and check the oil quantity (four to eight quarts). Eight quarts are required for maximum range. Secure the access door.

The propeller and spinner should be checked for detrimental nicks, cracks, or other defects, and the air inlets are clear of obstructions.

Next, verify that the scupper drain and fuel tank vent located on the underside of the wing, outboard of the nacelle, are clear of obstructions.

Remove the tiedown.

4.9d Left Wing (4.5a) (Continued)

Proceed along the leading edge of the wing to the stall warning vanes. Check both vanes for damage and freedom of movement. A squat switch in the stall warning system does not allow the unit to be activated on the ground.

Check the pitot/ static head. If installed, remove the cover from the pitot head on the underside of the wing. Make sure the holes are open and clear of obstructions. Next, check the wingtip and lights for damage.

Check the aileron, flap and hinges for damage and operational interference. Static wicks should be firmly attached and in good condition.

4.9e Fuselage (Left Side) (4.5a)

Check the general condition of the left side of the fuselage. The emergency exit should be secure and flush with the fuselage skin. All side windows should be clean and without defects. Antennas should be in place and securely attached. Check the fresh air inlet for any obstructions.

4.9f Empennage (4.5a)

Check that the empennage surfaces are clear of ice, frost, snow or other extraneous substances. All surfaces of the empennage should be examined for damage and operational interference. The stabilator and rudder should be operational and free from damage or interference of any type. Check the condition of the trim tabs and ensure that all hinges and push rods are sound and operational. Stabilator and rudder static wicks should be firmly attached and in good condition.

If the tail has been tied down, remove the tiedown rope.

4.9g Fuselage (Right Side) (4.5a)

Check the general condition of the right side of the fuselage. Check that the baggage door and cabin door attachments are secure and that the hinges are operational. Close and latch the baggage door.

4.9h Miscellaneous (4.5a)

Enter the cockpit and retract the flaps. Turn the battery master switch ON. Check the interior lights by turning ON the necessary switches. After the interior lights are checked, turn ON the pitot heat, and the exterior light switches. Next, perform a walk-around check of the exterior lights for proper operation, and the heated pitot head for proper heating.

CAUTION

Care should be taken when an operational check of the heated pitot head is being performed. The unit becomes very hot. Ground operation should be limited to 3 minutes maximum to avoid damaging the heating elements.

Reenter the cockpit and turn all switches OFF. At this time all passengers can be boarded.

4.11 BEFORE STARTING ENGINE (4.5b)

After preflight interior and exterior checks and flight planning have been completed and the airplane has been determined ready for flight, the cabin door should be secured. All seats should be adjusted and secured in position and seat belts and shoulder harnesses properly fastened.

NOTE

A pull test of the locking restraint feature should be performed on the inertial reel shoulder harness.

Turn on the alternator switches. Set the parking brake by first depressing and holding the toe brake pedals, then pull back on the parking brake knob. Verify that the landing gear selector is in the DOWN position.

Check that the control levers move smoothly and place the throttles at IDLE, the propeller controls to FULL INCREASE and the mixture controls at IDLE CUTOFF. Adjust the friction control as desired.

4.11 BEFORE STARTING ENGINE (4.5b) (Continued)

Verify that the carburetor heat for each engine is off and the cowl flaps are open.

Verify that both stabilator and rudder trim is set to neutral and that the fuel selectors are on.

All other electrical switches and radio master switch should be off to avoid an electrical overload when the starter is engaged. Check that all circuit breakers are in.

4.13 ENGINE START (4.5c)

NOTE

When starting at ambient temperatures +20°F and below, operate first engine started with alternator ON (at max charging rate not to exceed 1500 RPM) for 5 minutes minimum before initiating start on second engine.

4.13a Normal Start - Cold Engine (4.5c)

Turn the battery master switch ON and check that the three green gear position lights are illuminated. Open the throttles about 1/4 inch. Advance the propeller controls to full forward and the mixture controls to full rich. Start one engine at a time using the following procedure.

Turn the electric fuel pump on. Prime the engine as required. Verify the propeller area is clear, then turn on the magneto switches. Engage the starter.

When the engine starts, adjust the throttle and monitor the oil pressure. If no oil pressure is indicated within 30 seconds, shut down the engine and have it checked. In cold weather it may take somewhat longer for an oil pressure indication.

Repeat the above procedure for the opposite engine. After the engines have started, check the alternators for sufficient output and the gyro vacuum gauge for a reading between 4.8 and 5.2 in. Hg. and that the flow buttons are retracted.

4.13 ENGINE START(4.5c) (Continued)**NOTE**

To prevent starter damage, limit starter cranking to 30-second periods. If the engine does not start within that time, allow a cooling period of several minutes before engaging starter again. Do not engage the starter immediately after releasing it. This practice may damage the starter mechanism.

4.13b Normal Start - Hot Engine (4.5c)

Turn the battery master switch ON and check that the three green gear position lights are illuminated. If the engines are still warm from previous operation, begin by first opening the throttles 1/2 inch. Advance the propeller controls to full forward. Start one engine at a time using the following procedure.

Turn the electric fuel pump on. Advance the mixture control full rich. Verify the propeller area is clear and turn magnetos on. Engage the starter. When the engine starts, adjust the throttle and monitor the oil pressure. If no oil pressure is indicated within 30 seconds, shut down the engine and have it checked.

Repeat the above procedure for the opposite engine. After the engines have started, confirm that the alternators are on by checking the ammeters for output. Check the gyro vacuum gauge for a reading between 4.8 and 5.2 in Hg. and that the flow buttons are retracted.

4.13c Engine Start - Cold Weather (Below 10°F) (4.5c)**CAUTION**

Ensure magneto and master switches are OFF and mixture controls are in idle cut-off before turning propeller manually

If available, preheat should be considered. After checking that the battery master and magneto switches are OFF, and mixture controls are in idle cut-off, manually rotate each engine through 10 propeller blades during the preflight inspection. Refer to Section 4.13f before starting with external power.

4.13c Engine Start - Cold Weather (Below 10°F) (4.5c) (Continued)

Turn the battery master switch and alternator switches OFF. Verify the magneto switches are OFF and connect the external power. Turn ON the electric fuel pump, move the mixture control full rich, the propeller control full forward and open the throttle 1/4 inch. Next, prime as required, check that the propeller area is clear then turn on the magneto switches. Engage the starter.

When the engine starts, adjust the throttle and monitor the oil pressure. If engine does not start, add prime and repeat. When engine fires, prime as required until engine is running smoothly. Repeat the above procedure for the opposite engine.

After both engines have been started and warmed-up, reduce the throttles to the lowest possible RPM.

WARNING

Shut down the right engine when it is warmed prior to disconnecting the external power plug.

Shut down the right engine and disconnect the external power plug. After external power has been removed, turn the battery master switch and alternator switches ON. Restart the right engine using a normal start. After both engines have been started, check the alternators for sufficient output. Check the gyro vacuum gauge for a reading between 4.8 and 5.2 in Hg.

4.13d Engine Start When Flooded (4.5c)

If an engine is flooded (by overpriming, for example), the mixture should be pulled to idle cut-off. Advance the propeller control full forward and the throttle full open. Verify that the electric fuel pump is off. Turn the battery master switch ON, verify the propeller area is clear, then turn the magneto switches ON. Engage the starter.

Advance the mixture control only after the engine has started, and retard the throttle lever to 1000 RPM. Monitor the oil pressure. Confirm that the alternators are on by checking the ammeters for output. Check the gyro vacuum gauge for a reading between 4.8 and 5.2 in. Hg.

4.13e Engine Start With External Power Source (4.5c)**NOTE**

For all normal operations using the PEP jumper cables, the master switch should be OFF, but it is possible to use the ship's battery in parallel by turning the master switch ON. This will give longer cranking capabilities, but will not increase the amperage.

CAUTION

Care should be exercised because if the ship's battery has been depleted, the external power supply can be reduced to the level of the ship's battery. This can be tested by turning the master switch ON momentarily while the starter is engaged. If cranking speed increases, the ship's battery is at a higher level than the external power supply. If the battery has been depleted by excessive cranking, it must be recharged before the second engine is started. All the alternator current will go to the low battery until it receives sufficient charge, and it may not start the other engine immediately.

A feature called the Piper External Power (PEP) allows the operator to use an external battery to crank the engines without having to gain access to the airplane's battery.

Turn the battery master switch and all electrical equipment OFF. Connect the RED lead of the PEP kit jumper cable to the POSITIVE (+) terminal of an external 12-volt battery and the BLACK lead to the NEGATIVE (-) terminal. Insert the plug of the jumper cable into the receptacle located on the right side of the nose. Note that when the plug is inserted, the electrical system is ON. Proceed with the normal starting technique.

4.13e Engine Start With External Power Source (4.5c) (Continued)

WARNING

Shut down the right engine when it is warmed prior to disconnecting the external power plug.

After the engines have started, check the oil pressure, reduce power on the left engine to the lowest possible RPM to reduce sparking, and shut down the right engine. Disconnect the jumper cable from the aircraft. Turn the master switch ON and check the alternator ammeter for an indication of output. **DO NOT ATTEMPT FLIGHT IF THERE IS NO INDICATION OF ALTERNATOR OUTPUT.** Restart the right engine after the external power plug has been removed.

4.15 BEFORE TAXIING (4.5d)

4.15a. Warm-Up (4.5d)

Warm-up the engines at 1000 to 1200 RPM. Avoid prolonged idling at low RPM, as this practice may result in fouled spark plugs.

Takeoff may be made as soon as the ground check is completed, provided that the throttles may be opened fully without backfiring or skipping and without a reduction in engine oil pressure.

Do not operate the engines at high RPM when running up or taxiing over ground containing loose stones, gravel or any loose material that may cause damage to the propeller blades.

4.15b. Before Taxiing (4.5d)

If an External Power Source Unit has been used for starting, it should be disconnected and the battery master should be turned ON. Set the gyros, the altimeter and clock as required. Turn ON the radio master switch. Lights and heater may be turned on as desired. Check the radios, and set them as desired. Check the autopilot (See Section 9) and turn ON and check the electric trim.

Complete the passenger briefing. Release the parking brake by first depressing and holding the toe brake pedals and then pushing forward on the parking brake control.

4.17 TAXIING (4.5e)

Check to make sure the taxi area is clear. Always apply the throttles slowly. While taxiing, apply the brakes to determine their effectiveness. Make slight turns to check steering. During the taxi, check the instruments (turn indicator, directional gyro, coordination ball & compass). Check the operation of the fuel management controls by moving each fuel selector to crossfeed for a short time, while the other selector is in the ON position. Return the selectors to the ON position.

4.19 GROUND CHECK (4.5f)

Set the parking brake. Advance mixture and propeller controls. Check engine instruments to see that they are functional and that readings are within limitations. Set the throttles to an engine speed of 1500 RPM. Retard the propeller controls aft to check feathering; however, do not allow a drop of more than 500 RPM.

Advance the throttles until engine speed reaches 2000 RPM. Check the magnetos on each engine by turning OFF, then ON, each of four magneto switches in turn. The maximum drop when a magneto is turned off is 175 RPM. The maximum differential between magnetos on one engine is 50 RPM. After checking one magneto, do not check the next until the engine speed returns to 2000 RPM. Operation of an engine on one magneto should be kept to a minimum.

Exercise the propeller levers through their range to check their operation. Response should be normal. Do not allow speed to drop more than 300 RPM. The governor can be checked by retarding the propeller control until a drop of 100 RPM to 200 RPM appears, then advancing the throttle to get a slight increase in manifold pressure. The propeller speed should stay the same when the throttle is advanced, indicating proper function of the governor. Carburetor heat should also be checked prior to takeoff to be sure the control is operating properly and to purge any ice which may have formed during taxiing. Avoid prolonged ground operation with carburetor heat ON as the air is unfiltered.

Check alternator output - alternator output readings should be about equal. All annunciator lights should be out. Check that the gyro vacuum gauge is reading between 4.8 to 5.2 in. Hg. Retard the throttles to 500 to 600 RPM to check idling. Set the throttles at 1000 RPM, recheck the flight instruments, and reset them if necessary. Set the desired amount of friction on the engine control levers.

4.21 BEFORE TAKEOFF (4.5g)

Ensure proper flight control movement and response. Check that flight instruments are set and operational, and that all engine instruments are reading within limits. Check that the fuel quantity is sufficient for the intended flight. Turn the electric fuel pumps ON for takeoff. Check that the mixture controls are full forward. Ensure that the fuel selectors are on and set trim for takeoff.

The autopilot should be turned off during takeoff. Turn pitot heat ON if necessary. Verify that the carburetor heat selectors are off and cowl flaps are open. Recheck alternator output. Set avionics as required. Set the direction indicator if necessary and set the transponder as required.

Check the wing flaps for proper operation. Visually confirm that right and left wing flaps are equally extended. Set the flaps.

Check that no warning lights are illuminated. Verify that the cabin door is closed and latched. Release the parking brake.

4.23 TAKEOFF (4.5h)

CAUTION

Fast taxi turns immediately prior to takeoff should be avoided to prevent any possibility of fuel line unporting which could lead to engine stoppage on takeoff.

To maximize power availability for takeoffs from airports at higher elevations, the mixture should be leaned. Adjust mixture after takeoff power has been applied just enough to obtain smooth engine operation. Monitor engine temperatures to prevent overheating.

Takeoff should not be attempted with ice or frost on the wings. Takeoff distances and 50-foot obstacle clearance distances are shown on charts in the Performance Section of this Handbook. The performance shown on charts will be reduced by uphill gradient, tailwind component, or soft, wet, rough or grassy surface, or poor pilot technique.

4.23 TAKEOFF (4.5h) (Continued)

Avoid fast turns onto the runway followed by immediate takeoff, especially with a low fuel supply. As power is applied at the start of the takeoff roll, look at the engine instruments to see that the engines are operating properly and putting out normal power and at the airspeed indicator to see that it is functioning. Apply throttle smoothly.

The flap setting for normal takeoff is 0° to 10°. For short fields or fields with soft surface conditions or adjacent obstacles, total takeoff distances can be reduced appreciably by lowering flaps to 25° for takeoff.

4.23a Normal Takeoff (4.5h)

When obstacle clearance is no problem, a normal takeoff technique may be used with flaps set to 0° or 10°. Set the stabilator trim indicator in the takeoff range. Accelerate to 75 KIAS and ease back on the control wheel enough to let the airplane lift off. After lift-off, accelerate to the best rate of climb speed, 88 KIAS, retracting the landing gear and flaps, if applicable, while accelerating.

4.23b 0° Flap, Short Field Performance Takeoff (4.5h)

When a short field effort is required, the safest short field technique to use is with the flaps up (0°). In the event of an engine failure, the airplane is in the best flight configuration to sustain altitude immediately after the gear is raised.

Set the stabilator trim indicator in the takeoff range. Set the brakes and bring the engines to full power before release. Accelerate to 70 KIAS and rotate the airplane firmly so that the airspeed is approximately 82 KIAS when passing through the obstacle height. The airplane should then be allowed to accelerate to the best rate of climb speed (88 KIAS) when obstacles are not a problem. The landing gear should be retracted when a positive climb is achieved.

4.23b 0° Flap, Short Field Performance Takeoff (4.5h) (Continued)

NOTE

Gear warning horn will sound when landing gear is retracted with flaps extended beyond first notch.

When the shortest possible ground roll and the greatest clearance distance over a 50-foot obstacle is needed, a flap setting up to a maximum of 25° (second notch) may be used. Set the stabilator trim indicator slightly nose up from the takeoff range. When 25° of flaps are selected, procedures similar to those described for 0° flaps should be used with an obstacle speed no slower than 70 KIAS. Retract the gear when a gear-down landing is no longer possible on the runway. It should also be noted that when a 25-degree flap setting is used on the takeoff roll, an effort to hold the airplane on the runway too long may result in a wheelbarrowing tendency. This should be avoided.

This procedure should only be used when conditions truly require added performance. The pilot must be aware that he achieves this improved performance only at the expense of a reduction in his safety margins. If an engine failure were to occur near the obstacle with the gear and flaps still down, the only choice available to the pilot is to reduce the remaining power to idle and make the best possible landing straight ahead since single engine performance under these conditions is non-existent.

Because of reduced safety margins associated with 25° flap, short field takeoffs, performance data is only provided for 0° flap, short field takeoffs. Takeoff distances to be achieved using these procedures are included in Section 5 of this Handbook.

4.25 CLIMB (4.5i)

4.25a Takeoff Climb (4.5i)

On climb-out after takeoff, it is recommended that the best rate of climb speed (88 KIAS) be maintained with full power on the engines until adequate terrain clearance is obtained. If obstacle clearance is a consideration, maintain best angle of climb speed (82 KIAS) until clear of all obstacles, then accelerate to best rate of climb speed (88 KIAS). The cowl flaps should be OPEN and electric fuel pumps should be ON until level off is accomplished at desired cruise altitude.

4.25b Cruise Climb (4.5i)

At this point, engine power should be reduced to approximately 75% power for cruise climb. A cruise climb speed of 105 KIAS or higher is also recommended. This combination of reduced power and increased climb speed provides better engine cooling, less engine wear, reduced fuel consumption, lower cabin noise level, and better forward visibility.

When reducing engine power, the throttles should be retarded first, followed by the propeller controls. The mixture controls should remain at full rich during the climb. Cowl flaps should be adjusted to maintain cylinder head and oil temperatures within the normal ranges specified for the engine. The electric fuel pumps should be ON until level off is accomplished at desired cruise altitude.

Consistent operational use of cruise climb power settings is strongly recommended since this practice will make a substantial contribution to fuel economy and increased engine life, and will reduce the incidence of premature engine overhauls.

4.27 CRUISE (4.5j)

When leveling off at cruise altitude, the pilot may reduce to a cruise power setting in accordance with the Power Setting Table in this Handbook.

For maximum service life, cylinder head temperature should be maintained below 435°F during high performance cruise operation and below 400°F during economy cruise operation. If cylinder head temperatures become too high during flight, reduce them by enriching the mixture, by opening cowl flaps, by reducing power, or by use of any combination of these methods.

Following level off for cruise, the electric fuel pumps may be turned off, the cowl flaps should be closed or adjusted as necessary to maintain proper cylinder head temperatures, and the airplane should be trimmed to fly hands off.

The pilot should monitor weather conditions while flying and should be alert to conditions which might lead to icing. If induction system icing is expected, place the carburetor heat control in the ON position.

4.27 CRUISE (4.5j) (Continued)

WARNING

Flight in icing conditions is prohibited. If icing is encountered, immediate action should be taken to fly out of icing conditions. Icing is hazardous due to greatly reduced performance, loss of forward visibility, possible longitudinal control difficulties due to increased control sensitivity, and impaired power plant and fuel system operation.

The ammeters for the electrical system should be monitored during flight, especially during night or instrument flight, so that corrective measures can be taken in case of malfunction. The procedures for dealing with electrical failures are contained in the Emergency Procedure Section of this Handbook. The sooner a problem is recognized and corrective action taken, the greater is the chance of avoiding total electrical failure. Both alternator switches should be ON for normal operation. The two ammeters continuously indicate the alternator outputs. Certain regulator failures can cause the alternator output voltage to increase uncontrollably. To prevent damage, overvoltage relays are installed to automatically shut off the alternator(s). The amber alternator annunciator (ALT) on the annunciator panel will illuminate to warn of the tripped condition. Alternator outputs will vary with the electrical equipment in use and the state of charge of the battery. Alternator outputs should not exceed 60 amperes. The red low voltage annunciator (LO BUS) will warn of bus voltage below requirements.

It is not recommended to takeoff into IFR operation with a single alternator. During flight, electrical loads should be limited to 50 amperes for each alternator. Although the alternators are capable of 60 amperes output, limiting loads to 50 amperes will assure battery charging current.

Since the Seminole has one fuel tank per engine, it is advisable to feed the engines symmetrically during cruise so that approximately the same amount of fuel will be left in each side for the landing. A crossfeed is provided and can be used to even up the fuel, if necessary.

4.27 CRUISE (4.5j) (Continued)

During flight, keep account of time and fuel used in connection with power settings to determine how the fuel flow and fuel quantity gauging systems are operating.

There are no mechanical uplocks in the landing gear system. In the event of a hydraulic system malfunction, the landing gear will free-fall to the gear down position. The true airspeed with gear down is approximately 75% of the gear retracted airspeed for any given power setting. Allowances for the reduction in airspeed and range should be made when planning extended flight between remote airfields or flight over water.

4.29 DESCENT (4.5k)

When power is reduced for descent, the mixtures should be enriched as altitude decreases. The propellers may be left at cruise setting; however, if the propeller speed is reduced, it should be done after the throttles have been retarded. Cowl flaps should normally be closed to keep the engines at the proper operating temperature.

4.31 APPROACH AND LANDING (4.5m)

Sometime during the approach for a landing, the throttle controls should be retarded to check the gear warning horn. Flying the airplane with the horn inoperative is not advisable. Doing so can lead to a gear up landing as it is easy to forget the landing gear, especially when approaching for a one engine inoperative landing, or when other equipment is inoperative, or when attention is drawn to events outside the cabin.

The red landing gear unsafe light (WARN GEAR UNSAFE) will illuminate when the landing gear is in transition between the full up position and the down and locked position. Additionally, the light will illuminate when the gear warning horn sounds. The gear warning horn will sound at low throttle settings if the gear is not down and locked and when landing flaps are selected and the gear is not down and locked.

The light is off when the landing gear is in either the full down and locked or full up positions.

4.31 APPROACH AND LANDING (4.5m) (Continued)

Prior to entering the traffic pattern, the aircraft should be slowed to approximately 100 KIAS, and this speed should be maintained on the downwind leg. The landing check should be made on the downwind leg. The seat backs should be erect, and the seat belts and shoulder harnesses should be fastened.

NOTE

A pull test of the inertia reel locking restraint feature should be performed.

Both fuel selectors should normally be ON, and the cowl flaps should be set as required. The electric fuel pumps should be ON. Select landing gear DOWN and check for three green lights on the panel and look for the nose wheel in the nose wheel mirror. The landing gear should be lowered at speeds below 140 KIAS and the flaps at speeds below 111 KIAS.

Maintain a traffic pattern speed of 100 KIAS and a final approach speed of 90 KIAS. If the aircraft is lightly loaded, the final approach speed may be reduced to 80 KIAS. Set the mixture controls to full rich.

When the power is reduced on close final approach, the propeller controls should be advanced to the full forward position to provide maximum power in the event of a go-around.

The landing gear position should be checked on the downwind leg and again on final approach by checking the three green indicator lights on the instrument panel and looking at the external mirror to check that the nose gear is extended. Remember that when the navigation lights are on, the gear position lights are dimmed and are difficult to see in the daytime.

Operate the toe brakes to determine if there is sufficient pressure for normal braking and make sure that the parking brake is not set. Verify that the mixture and propeller controls are full forward. Carburetor heat should be used if induction icing is suspected. The autopilot should be OFF for landing.

4.31 APPROACH AND LANDING (4.5m) (Continued)**4.31a Normal Landing (4.5m)**

Landing may be made with any flap setting. Normally full flaps are used. Full flaps will reduce stall speed during final approach and will permit contact with the runway at a slower speed.

Good pattern management includes a smooth, gradual reduction of power on final approach with the power fully off before the wheels touch the runway. This gives the gear warning horn a chance to blow if the gear is not locked down. Electric trim can be used to assist a smooth back pressure during flare-out. Hold the nose up as long as possible before and after contacting the ground with the main wheels.

Maximum braking after touch-down is achieved by retracting the flaps, applying back pressure to the wheel and applying pressure on the brakes. However, unless extra braking is needed or unless a strong crosswind or gusty air condition exists, it is best to wait until turning off the runway to retract the flaps. This will permit full attention to be given to the landing and landing roll and will also prevent the pilot from accidentally reaching for the gear handle instead of the flap handle.

If a crosswind or high-wind landing is necessary, approach with higher than normal speed and with zero to 25 degrees of flaps. Immediately after touch-down, raise the flaps. During a crosswind approach hold a crab angle into the wind until ready to flare out for the landing. Then lower the wing that is into the wind to eliminate the crab angle without drifting, and use the rudder to keep the wheels aligned with the runway. Avoid prolonged side slips with a low fuel indication.

The maximum demonstrated crosswind component for landing is 17 KTS.

4.31b Short Field Performance Landing (4.5m)

For landings on short runways of runways with adjacent obstructions, a short field landing technique should be used in accordance with the charts in Section 5. The airplane should be flown down final with full flaps at 75 KIAS (at maximum weight) so as to cross any obstructions with the throttles at idle. Immediately after touch-down, raise the flaps and apply back pressure to the control wheel as maximum braking is applied.

4.33 GO-AROUND (4.5n)

If a go-around from a normal approach with the airplane in the landing configuration becomes necessary, apply takeoff power to both engines by moving the mixture controls, propeller controls and throttle controls full forward. Establish a positive climb attitude, retract the flaps and landing gear and adjust the cowl flap for adequate engine cooling.

4.35 AFTER LANDING (4.5o)

When clear of the active runway, retract the flaps and open the cowl flaps. Test the toe brakes, a spongy pedal is often an indication that the brake fluid needs replenishing. The carburetor heat controls should be OFF. Turn both electric fuel pumps OFF and use the Landing/Taxi light as required.

4.37 STOPPING ENGINE (4.5p)

Prior to shutdown turn all radio and electrical equipment and external lights OFF. Move the throttle controls full aft to idle and the mixture controls to idle cut-off. Turn OFF the magneto, the alternator and battery master switches. Also, at night, turn OFF the panel lights .

NOTE

The flaps must be placed in the "UP" position for the flap step to support weight. Passengers should be cautioned accordingly.

4.39 MOORING (4.5q)

If necessary, the airplane should be moved on the ground with the aid of the optional nose wheel tow bar.

The parking brake should be set and the ailerons and stabilator should be secured by looping the seat belt through the control wheel and pulling it snug. The rudder need not be secured under normal conditions, as its connection to the nose wheel holds it in position. The flaps are locked when in the fully retracted position.

Wheel chocks should be positioned in place. Tie-down ropes may be attached to mooring rings under each wing and to the tail skid.

4.41 STALLS

The loss of altitude during a power off stall with the gear and flaps retracted may be as much as 300 feet.

NOTE

The stall warning system is inoperative with the master switch OFF.

During preflight, the stall warning system should be checked by turning the battery switch on and lightly lifting up on the stall warning vanes on the left wing to determine if the horn is actuated.

4.43 TURBULENT AIR OPERATION

In keeping with good operating practice used in all aircraft, it is recommended that when turbulent air is encountered or expected, the airspeed be reduced to maneuvering speed to reduce the structural loads caused by gusts and to allow for inadvertent speed build-ups which may occur as a result of the turbulence or of distractions caused by the conditions. (See Subsection 2.3)

4.45 VSSE - INTENTIONAL ONE ENGINE INOPERATIVE SPEED

VSSE is a speed selected by the aircraft manufacturer as a training aid for pilots in the handling of multi-engine aircraft. It is the minimum speed for intentionally rendering one engine inoperative in flight. This minimum speed provides the margin the manufacturer recommends for use when intentionally performing engine inoperative maneuvers during training in the particular airplane.

VSSE is not a limitation. However, it is recommended that, except for training, demonstrations, takeoffs, and landings, the airplane should not be flown at a speed slower than VSSE.

The intentional one engine inoperative speed, VSSE, for the PA-44-180 is 82 KIAS.

4.47 VMCA - AIR MINIMUM CONTROL SPEED

VMCA is the minimum flight speed at which a twin-engine airplane is directionally and/or laterally controllable as determined in accordance with Federal Aviation Regulations. Airplane certification conditions include one engine becoming inoperative and windmilling; not more than a 5° bank toward the operative engine; landing gear up; flaps in takeoff position; and most rearward center of gravity.

VMCA for the PA-44-180 has been determined to be 56 KIAS and is a stalled condition.

The VMCA demonstration, which may be required for the FAA flight test for the multi-engine rating, approaches an uncontrolled flight condition with power reduced on one engine. The demonstration and all intentional one engine operations should not be performed at an altitude of less than 4000 feet above the ground. The recommended procedure for VMCA demonstration is to reduce the power to idle on the simulated inoperative engine at or above the intentional one engine inoperative speed, VSSE, and slow down approximately one knot per second until the FAA Required Demonstration Speed, stall buffet or warning, rudder or ailerons at full travel, or VMCA (red line on the Airspeed Indicator) is reached.

VMCA DEMONSTRATION

- (a) Landing GearUP
- (b) Flaps.....UP
- (c) Airspeedat or above 82 KIAS (VSSE)
- (d) Mixture.....FULL RICH
- (e) Propeller ControlsHIGH RPM
- (f) Throttle (Simulated Inoperative Engine).....IDLE
- (g) Throttle (Other Engine).....FULL FORWARD
- (h) AirspeedReduce approximately 1 knot per second
until either STALL WARNING, FULL
CONTROL TRAVEL or VMCA is obtained

4.47 VMCA - AIR MINIMUM CONTROL SPEED (Continued)*CAUTION*

Use rudder to maintain directional control (heading) and ailerons to maintain 5° bank towards the operative engine (lateral attitude). At the first sign of either VMCA (airspeed indicator redline) or stall warning (which may be evidenced by: inability to maintain heading or bank attitude, aerodynamic stall buffet, or stall warning horn), immediately initiate recovery; reduce power to idle on the operative engine, and immediately lower the nose to regain VMCA and continue accelerating to VSSE.

CAUTION

One engine inoperative stalls are not recommended.

Under no circumstances should an attempt be made to fly at a speed below VMCA with only one engine operating.

4.49 PRACTICE ONE ENGINE INOPERATIVE FLIGHT

Simulated one engine inoperative flight can be practiced without actually shutting down one engine by setting the propeller rpm of an engine to approximate zero thrust. This is accomplished at typical training altitudes with the throttle adjusted to produce the appropriate engine speed shown below and the mixture full rich, or leaned as required for smooth low power operation.

Propeller rpm for Zero Thrust

CIAS	RPM
82 VSSE	1850
88 VYSE	2180
100	2510
110	2690

4.51 NOISE LEVEL

The corrected noise level of this aircraft is 74.7 d B(A) with the two blade propeller.

No determination has been made by the Federal Aviation Administration that the noise levels of this airplane are or should be acceptable or unacceptable for operation at, into, or out of, any airport.

The above statement notwithstanding, the noise level stated above has been verified by and approved by the Federal Aviation Administration in noise level test flights conducted in accordance with FAR 36, Noise Standards - Aircraft Type and Airworthiness Certification. This aircraft model is in compliance with all FAR 36 noise standards applicable to this type.

TABLE OF CONTENTS
SECTION 5
PERFORMANCE

Paragraph No.		Page No.
5.1	General	5-1
5.3	Introduction - Performance and Flight Planning.....	5-1
5.5	Flight Planning Example.....	5-3
5.7	Performance Graphs.....	5-9
	List of Figures.....	5-9

THIS PAGE INTENTIONALLY LEFT BLANK

SECTION 5
PERFORMANCE

5.1 GENERAL

All of the required (FAA regulations) and complementary performance information applicable to this aircraft is provided by this section.

Performance information associated with those optional systems and equipment which require handbook supplements is provided by Section 9 (Supplements).

5.3 INTRODUCTION - PERFORMANCE AND FLIGHT PLANNING

The performance information presented in this section is based on measured Flight Test Data corrected to I.C.A.O. standard day conditions and analytically expanded for the various parameters of weight, altitude, temperature, etc.

The performance charts are unfactored and do not make any allowance for varying degrees of pilot proficiency or mechanical deterioration of the aircraft. This performance, however, can be duplicated by following the stated procedures in a properly maintained airplane.

Effects of conditions not considered on the charts must be evaluated by the pilot, such as the effect of soft or grass runway surface on takeoff and landing performance, or the effect of winds aloft on cruise and range performance. Endurance can be grossly affected by improper leaning procedures, and inflight fuel flow and quantity checks are recommended.

REMEMBER! To get chart performance, follow the chart procedures.

5.3 INTRODUCTION - PERFORMANCE AND FLIGHT PLANNING
(Continued)

The information provided by paragraph 5.5 (Flight Planning Example) outlines a detailed flight plan using the performance charts in this section. Each chart includes its own example to show how it is used.

WARNING

Performance information derived by extrapolation beyond the limits shown on the charts should not be used for flight planning purposes.

5.5 FLIGHT PLANNING EXAMPLE**(a) Aircraft Loading**

The first step in planning a flight is to calculate the airplane weight and center of gravity by utilizing the information provided by Section 6 (Weight and Balance) of this handbook.

The basic empty weight for the airplane as delivered from the factory has been entered in Figure 6-5. If any alterations to the airplane have been made affecting weight and balance, reference to the aircraft logbook and Weight and Balance Record (Figure 6-7) should be made to determine the current basic empty weight of the airplane.

Make use of the Weight and Balance Loading Form (Figure 6-11) and the C.G. Range and Weight graph (Figure 6-15) to determine the total weight of the airplane and the center of gravity position.

After proper utilization of the information provided, the following weights have been found for consideration in the flight planning example.

The landing weight cannot be determined until the weight of the fuel to be used has been established [refer to item (g)(1)].

(1) Basic Empty Weight	2589 lb
(2) Occupants (2 x 170 lb)	340 lb
(3) Baggage and Cargo	21 lb
(4) Fuel (6 lb./gal. x 80)	480 lb
(5) Takeoff Weight (3800 lb. max. allowable)	3430 lb
(6) Landing Weight	
(a)(5) minus (g)(1),	
(3430 lb minus 323 lb)	3107 lb

Takeoff and landing weights are below the maximums, and the weight and balance calculations have determined the C.G. position within the approved limits.

(b) Takeoff and Landing

Now that the aircraft loading has been determined, all aspects of the takeoff and landing must be considered.

5.5 FLIGHT PLANNING EXAMPLE (Continued)

All of the existing conditions at the departure and destination airport must be acquired, evaluated and maintained throughout the flight.

Apply the departure airport conditions and takeoff weight to the appropriate Takeoff performance graphs (Figures 5-11 and 5-13) to determine the length of runway necessary for the takeoff and/or the obstacle distance.

The landing distance calculations are performed in the same manner using the existing conditions at the destination airport and, when established, the landing weight.

The conditions and calculations for the example flight are listed below. The takeoff and landing distances required for the example flight have fallen well below the available runway lengths.

	Departure Airport	Destination Airport
(1) Pressure Altitude	1250 ft.	680 ft.
(2) Temperature	8°C	8°C
(3) Wind Component (Headwind)	6 KTS	5 KTS
(4) Runway Length Available	7400 ft.	9000 ft.
(5) Runway Required (Short Field Effort)		
Takeoff	1520 ft.*	
Landing		1238 ft.**

NOTE

The remainder of the performance charts used in this flight plan example assume a no wind condition. The effect of winds aloft must be considered by the pilot when computing climb, cruise and descent performance.

*reference Figure 5-13

**reference Figure 5-33

5.5 FLIGHT PLANNING EXAMPLE (Continued)

(c) Climb

The next step in the flight plan is to determine the necessary climb segment components.

The desired cruise pressure altitude and corresponding cruise outside air temperature values are the first variables to be considered in determining the climb components from the Fuel, Time and Distance to Climb graph (Figure 5-21). After the fuel, time and distance for the cruise pressure altitude and outside air temperature values have been established, apply the existing conditions at the departure field to graph (Figure 5-21). Now subtract the values obtained from the graph for the field of departure conditions from those for the cruise pressure altitude.

The remaining values are the true fuel, time and distance components for the climb segment of the flight plan corrected for field pressure altitude and temperature.

The following values were determined from the above instructions in the flight planning example.

(1) Cruise Pressure Altitude	5500 ft.
(2) Cruise OAT	-2°C
(3) Fuel to Climb (2.6 gal. minus 0.4 gal.)	2.2 gal.*
(4) Time to Climb (4.5 min. minus 0.9 min.)	3.6 min.*
(5) Distance to Climb (7.3 naut. miles minus 1.4 naut. miles)	5.9 naut. miles*

*reference Figure 5-21

5.5 FLIGHT PLANNING EXAMPLE (Continued)

(d) Descent

The descent data will be determined prior to the cruise data to provide the descent distance for establishing the total cruise distance.

Utilizing the cruise pressure altitude and OAT determine the basic fuel, time and distance for descent (Figure 5-31). These figures must be adjusted for the field pressure altitude and temperature at the destination airport. To find the necessary adjustment values, use the existing pressure altitude and temperature conditions at the destination airport as variables to find the fuel, time and distance values from the graph (Figure 5-31). Now, subtract the values obtained from the field conditions from the values obtained from the cruise conditions to find the true fuel, time and distance values needed for the flight plan.

The values obtained by proper utilization of the graphs for the descent segment of the example are shown below.

- | | |
|--------------------------------------|-----------------|
| (1) Fuel to Descend | |
| (3 gal. minus 1 gal.) | 2 gal.* |
| (2) Time to Descend | |
| (9 min. minus 2 min.) | 7 min.* |
| (3) Distance to Descend | |
| (30 naut. miles minus 4 naut. miles) | 26 naut. miles* |

*reference Figure 5-31

5.5 FLIGHT PLANNING EXAMPLE (Continued)**(e) Cruise**

Using the total distance to be traveled during the flight, subtract the previously calculated distance to climb and distance to descend to establish the total cruise distance. Refer to the appropriate Lycoming Operator's Manual and the Fuel and Power Setting Tables when selecting the cruise power setting. The established pressure altitude and temperature values and the selected cruise power should now be utilized to determine the true airspeed from the Speed Power graph (Figure 5-25).

Calculate the cruise fuel for the cruise power setting from the information provided on Figure 5-25.

The cruise time is found by dividing the cruise distance by the cruise speed and the cruise fuel is found by multiplying the cruise fuel flow by the cruise time.

The cruise calculations established for the cruise segment of the flight planning example are as follows:

(1) Total Distance	431 miles
(2) Cruise Distance	
(e)(1) minus (c)(5) minus (d)(3),	
(431 naut. miles minus	
5.9 naut. miles minus	
26 naut. miles)	399 naut. miles
(3) Cruise Power	
(Performance Cruise Mixture)	55% rated power
(4) Cruise Speed	140 KTS TAS*
(5) Cruise Fuel Consumption	17.4 GPH*
(6) Cruise Time	
(e)(2) divided by (e)(4),	
(399 naut. miles divided by 140 KTS)	2.85 hrs.
(7) Cruise Fuel	
(e)(5) multiplied by (e)(6),	
(17.4 GPH multiplied by 2.85 hrs.)	49.6 gal.

*reference Figure 5-25

5.5 FLIGHT PLANNING EXAMPLE (Continued)

(f) Total Flight Time

The total flight time is determined by adding the time to climb, the time to descend and the cruise time. Remember! The time values taken from the climb and descent graphs are in minutes and must be converted to hours before adding them to the cruise time.

The following flight time is required for the flight planning example.

- (1) Total Flight Time
(c)(4) plus (d)(2) plus (e)(6),
(0.06 hrs. plus 0.12 hrs. plus 2.85 hrs.) 3.03 hrs.

(g) Total Fuel Required

Determine the total fuel required by adding the fuel to climb, the fuel to descend and the cruise fuel. When the total fuel (in gallons) is determined, multiply this value by 6 lb./ gal. to determine the total fuel weight used for the flight.

The total fuel calculations for the example flight plan are shown below.

- (1) Total Fuel Required
(c)(3) plus (d)(1) plus (e)(7),
(2.2 gal. plus 2 gal. plus 49.6 gal.) 53.8 gal
(53.8 gal. multiplied by 6 lb./gal.) 323 lb

5.7 PERFORMANCE GRAPHS

LIST OF FIGURES

Figure No.		Page No.
5-1	Temperature Conversion	5-11
5-3	Airspeed Calibration	5-12
5-5	Stall Speed Vs. Angle of Bank	5-13
5-7	ISA Conversion	5-14
5-9	Wind Components.....	5-15
5-10	Accelerate and Stop Distance - Short Field Effort.....	5-16
5-11	Takeoff Ground Roll - Short Field Effort.....	5-17
5-13	Takeoff Distance Over 50 Ft. Obstacle - Short Field Effort	5-19
5-15	Climb Performance - Both Engines Operating - Gear Down	5-21
5-17	Climb Performance - Both Engines Operating- Gear Up	5-23
5-19	Climb Performance - One Engine Operating - Gear Up	5-24
5-21	Fuel, Time and Distance to Climb	5-25
5-23	Fuel and Power Setting Table.....	5-26
5-25	Speed Power.....	5-27
5-27	Standard Temperature Range and Endurance - Performance Cruise	5-29
5-29	Standard Temperature Range and Endurance - Economy Cruise.....	5-31
5-31	Fuel, Time and Distance to Descend.....	5-32
5-33	Landing Distance Over 50 Ft. Obstacle - Short Field Effort.....	5-33
5-35	Landing Ground Roll - Short Field Effort.....	5-34

THIS PAGE INTENTIONALLY LEFT BLANK

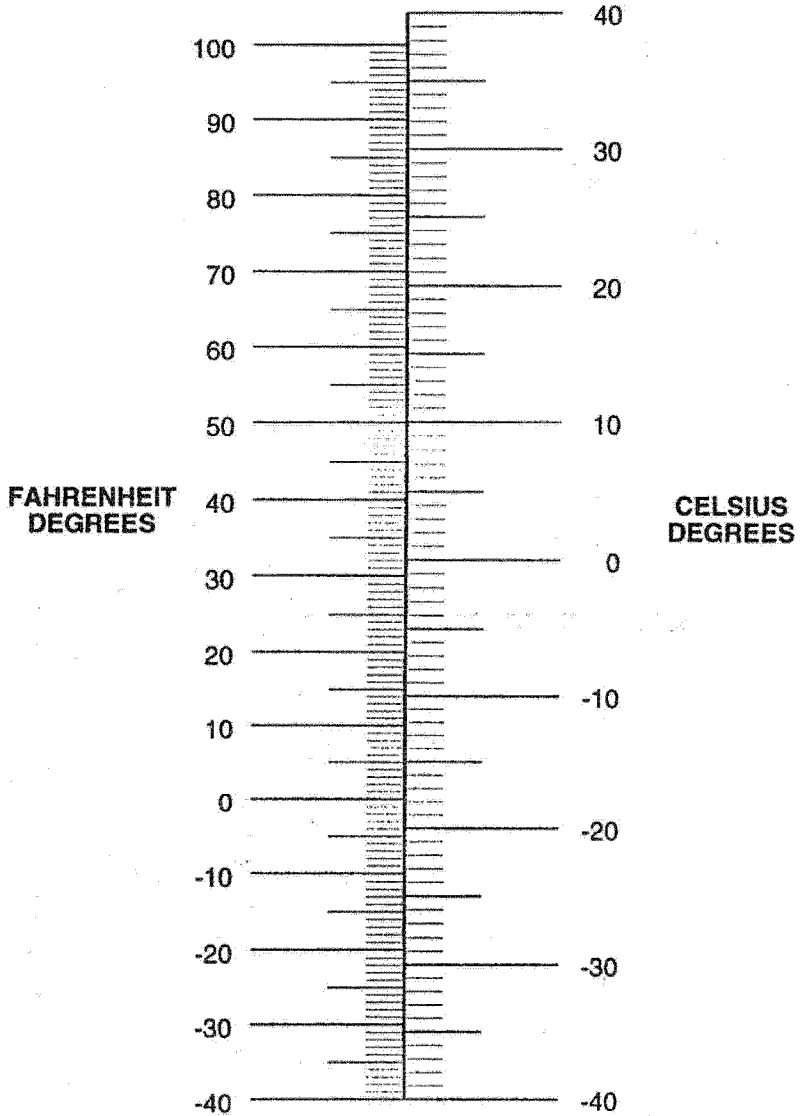

TEMPERATURE CONVERSION

Figure 5-1

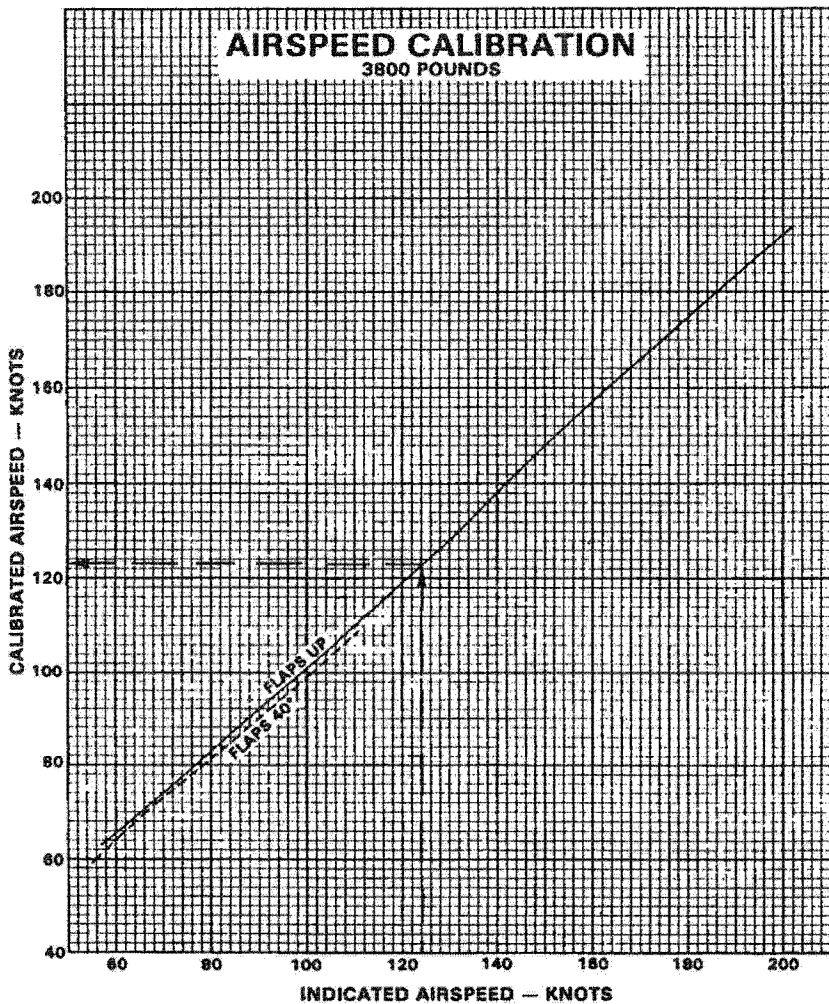

Example:
Indicated airspeed: 124 knots
Flaps up
Calibrated airspeed: 123 knots

AIRSPEED CALIBRATION

Figure 5-3

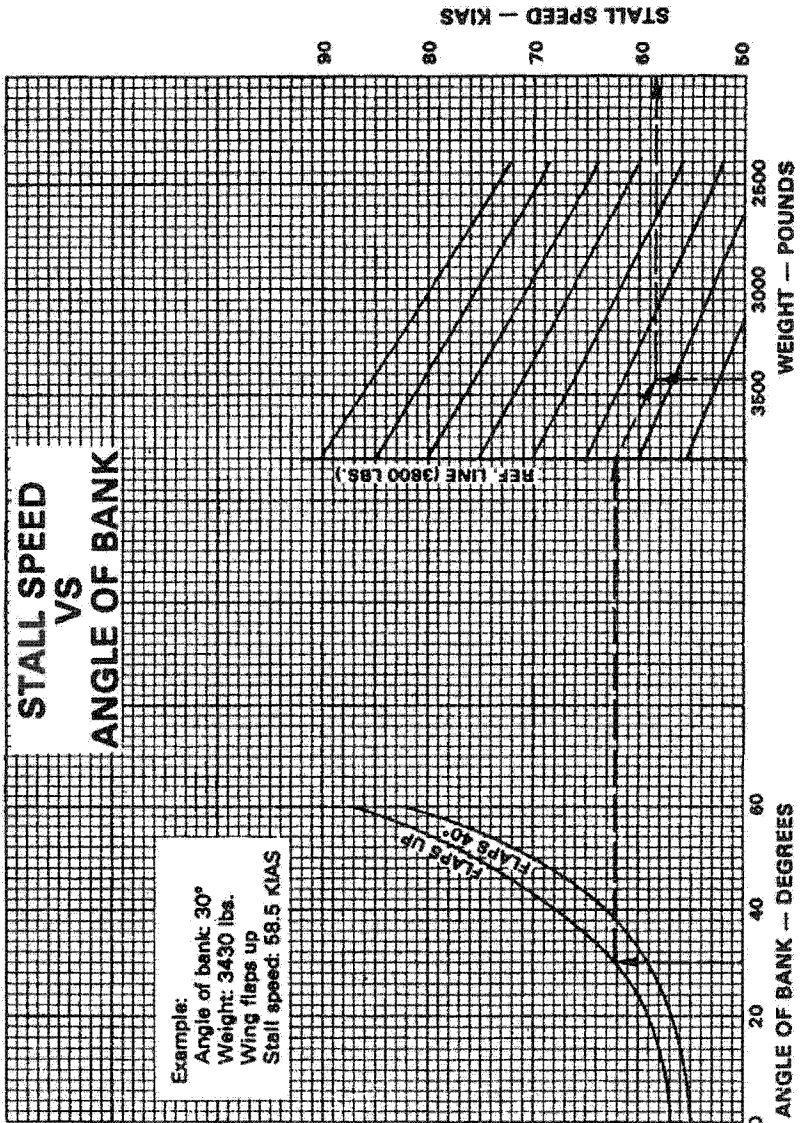

STALL SPEED VS. ANGLE OF BANK

Figure 5-5

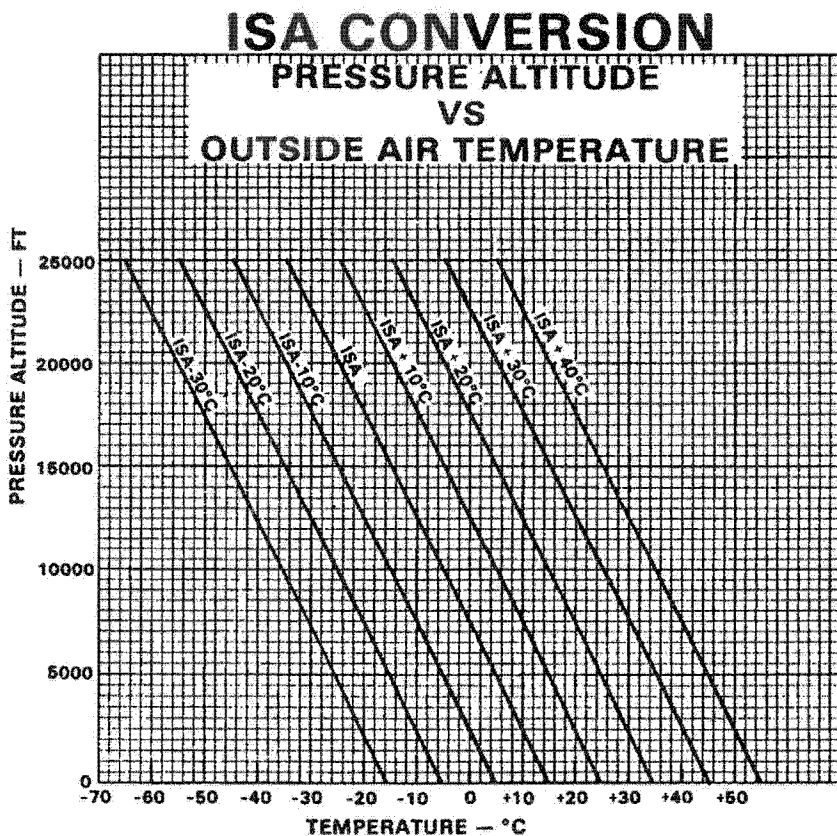

ISA CONVERSION

Figure 5-7

WIND COMPONENTS

Example:
Wind velocity: 30 KT
Angle between flight path and wind: 30°
Headwind: 26 KT
Crosswind component: 15 KT

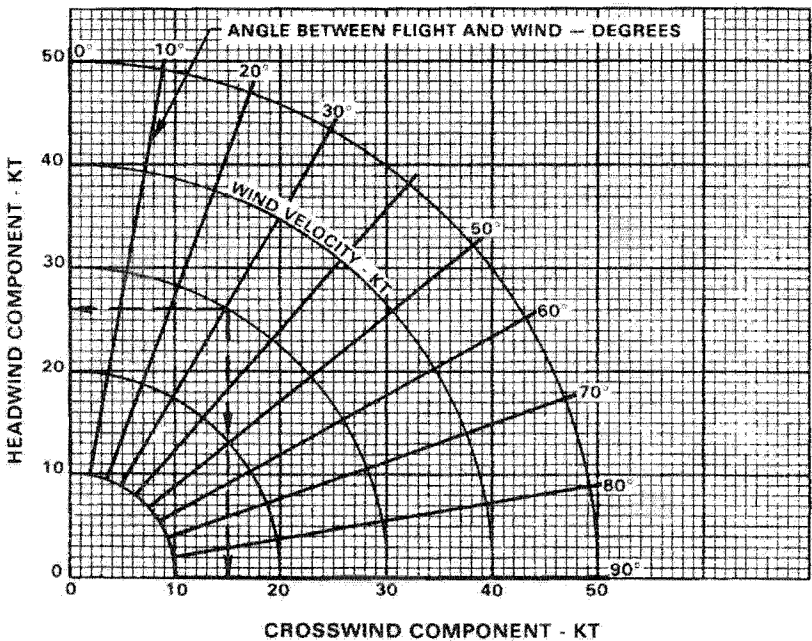

WIND COMPONENTS

Figure 5-9

PA-44-180

SHORT FIELD ACCELERATE AND STOP DISTANCE

BOTH ENGINES 2700 RPM & FULL THROTTLE
MIXTURE FULL RICH
WING FLAPS 0° - ABORT SPEED AT
SCHEDULED ROTATION SPEED
COWL FLAPS OPEN
PAVED LEVEL DRY RUNWAY
MAXIMUM BRAKING

Example:

Airport press. alt.: 680 ft.

Outside air temp.: 8°C

Weight: 3430 lbs.

Wind component: 5 kts. headwind

Accelerate & stop distance: 1750 ft.

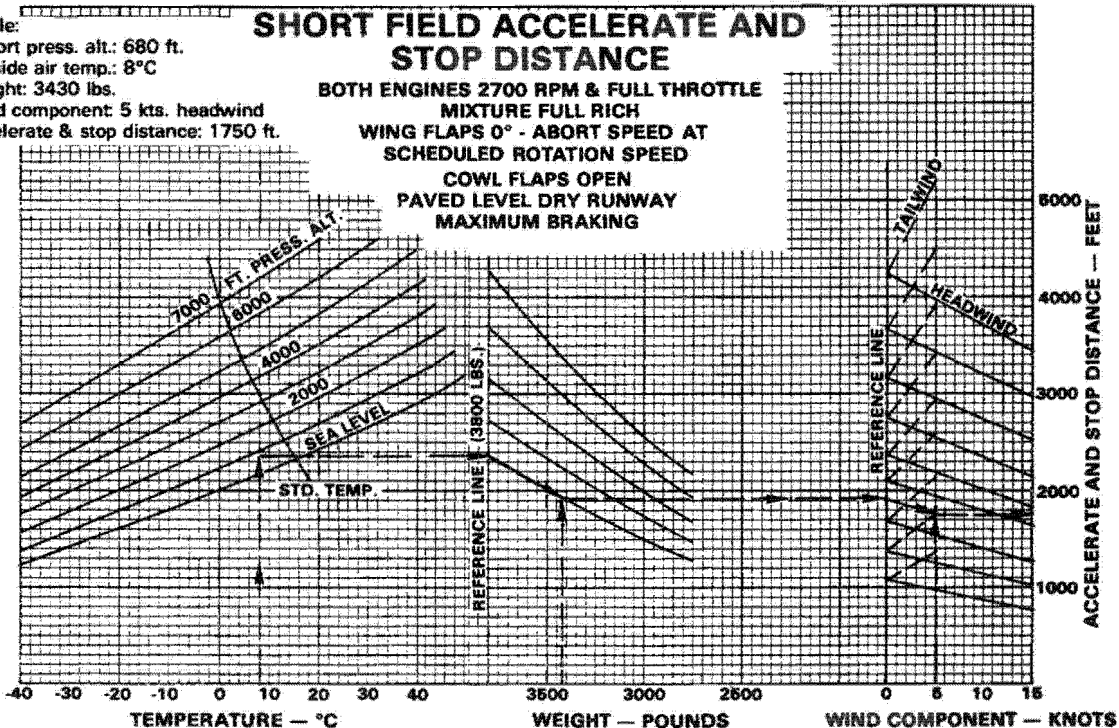

ACCELERATE AND STOP DISTANCE - SHORT FIELD EFFORT

Figure 5-10

TAKEOFF GROUND ROLL - SHORT FIELD EFFORT

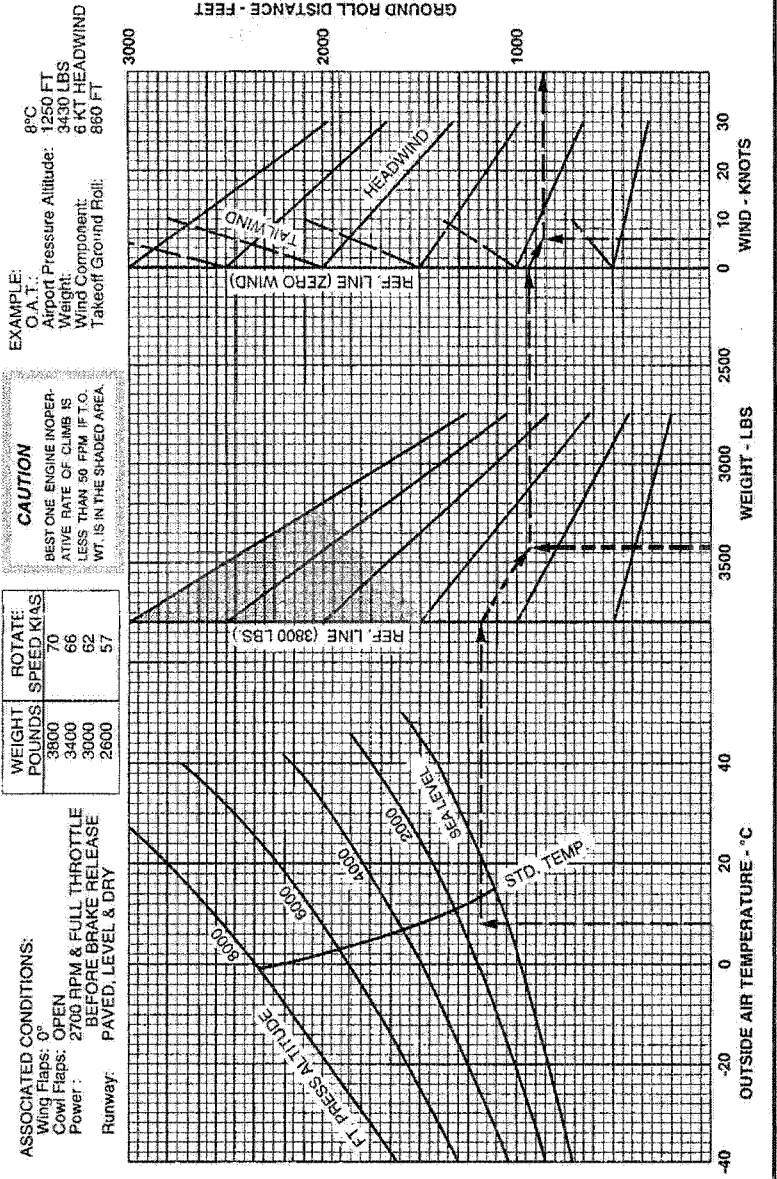

TAKEOFF GROUND ROLL - SHORT FIELD EFFORT

Figure 5-11

THIS PAGE INTENTIONALLY LEFT BLANK.

TAKEOFF DISTANCE OVER 50 FT OBSTACLE - SHORT FIELD EFFORT

ASSOCIATED CONDITIONS:

Wing Flaps: 0°
 Cowl Flaps: OPEN
 Power: 2700 RPM & FULL THROTTLE
 BEFORE BRAKE RELEASE
 Runway: PAVED, LEVEL & DRY

WEIGHT POUNDS	ROTATE SPEED KIAS	OBSTACLE SPEED KIAS
3800	70	82
3400	66	77
3000	62	72
2600	57	67

CAUTION

BEST ONE ENGINE INOPERATIVE RATE OF CLIMB IS LESS THAN 50 FPM IF T.D. WT. IS IN THE SHADED AREA.

EXAMPLE:

O.A.T.: 8°C
 Airport Pressure Altitude: 1250 FT
 Weight: 3430 LBS
 Wind Component: 6 KT HEADWIND
 Takeoff Distance
 Over 50 FT Obstacle: 1520 FT

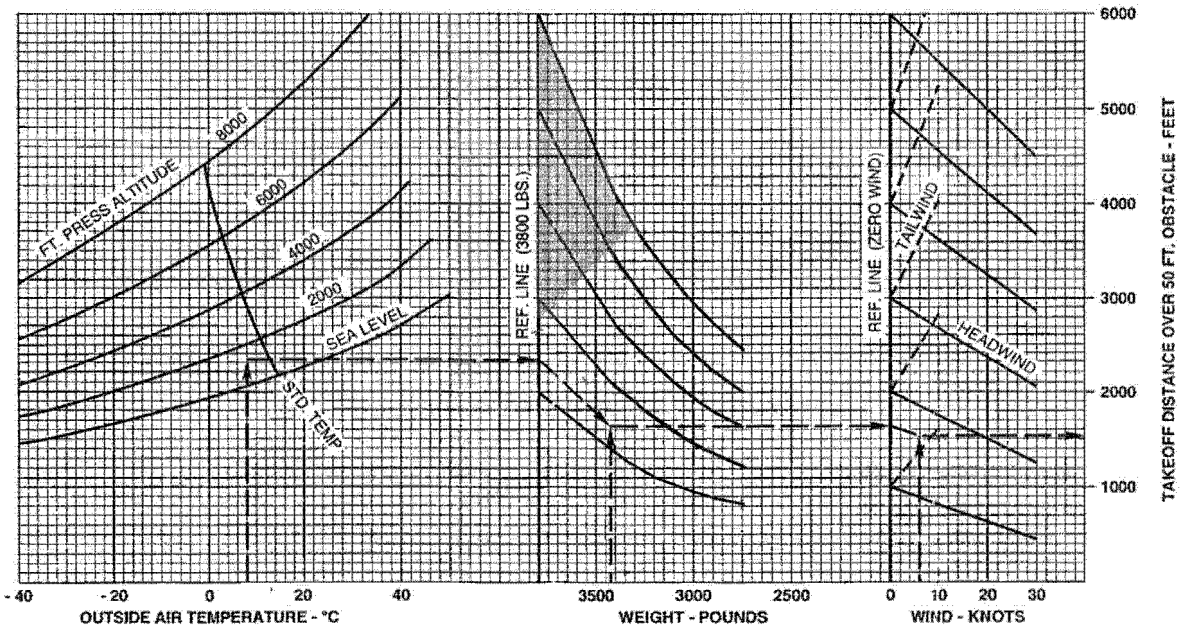

TAKEOFF DISTANCE OVER 50 FT. OBSTACLE - SHORT FIELD EFFORT
Figure 5-13

THIS PAGE INTENTIONALLY LEFT BLANK

CLIMB PERFORMANCE - BOTH ENGINES OPERATING - GEAR DOWN

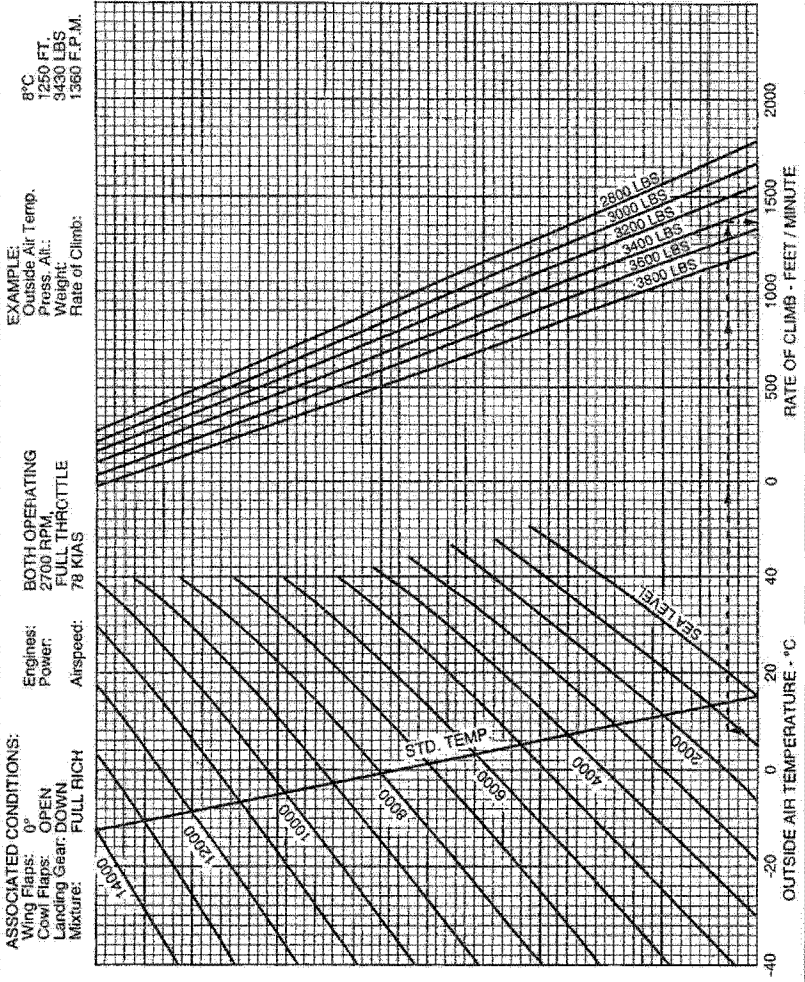

CLIMB PERFORMANCE - BOTH ENGINES OPERATING - GEAR DOWN

Figure 5-15

THIS PAGE INTENTIONALLY LEFT BLANK

CLIMB PERFORMANCE - BOTH ENGINES OPERATING - GEAR UP

ASSOCIATED CONDITIONS:
 FULL THROTTLE, 2700 RPM
 Power Flaps
 Cowl Flaps
 Mixture
 FULL RICH
 88 KIAS
 Wing Flaps
 0

Engines:
 Landing Gear:
 UP

BOTH OPERATING
 UP

EXAMPLE:
 Press. Alt.: 1250 FT.
 Outside Air Temp. 8°C
 Weight: 3430 LBS
 Rate of Climb: 1505 FT/MIN

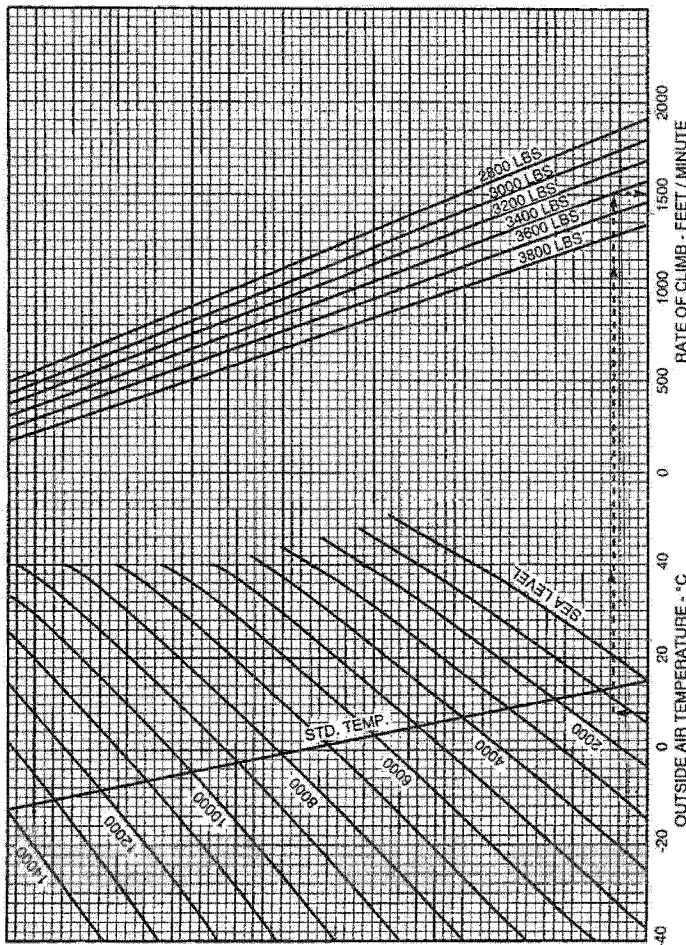

CLIMB PERFORMANCE - BOTH ENGINES OPERATING - GEAR UP

Figure 5-17

CLIMB PERFORMANCE - ONE ENGINE OPERATING - GEAR UP

ASSOCIATED CONDITIONS:

Wing Flaps: 0°
Cowl Flaps: (Operating Engine): OPEN
(Inoperative Engine): CLOSED
Landing Gear: UP

Mixture: FULL RICH
Prop: (Inoperative Engine): FEATHERED
Power: 2700 RPM
Airspeed: 88 KIAS
FULL THROTTLE

NOTE

2° TO 3° BANK TOWARD
OPERATING ENGINE

EXAMPLE:

Outside Air Temp.: 8°C
Press Alt.: 1250 FT.
Weight: 3430
One Engine
Inoperative Climb: 285 F.P.M.

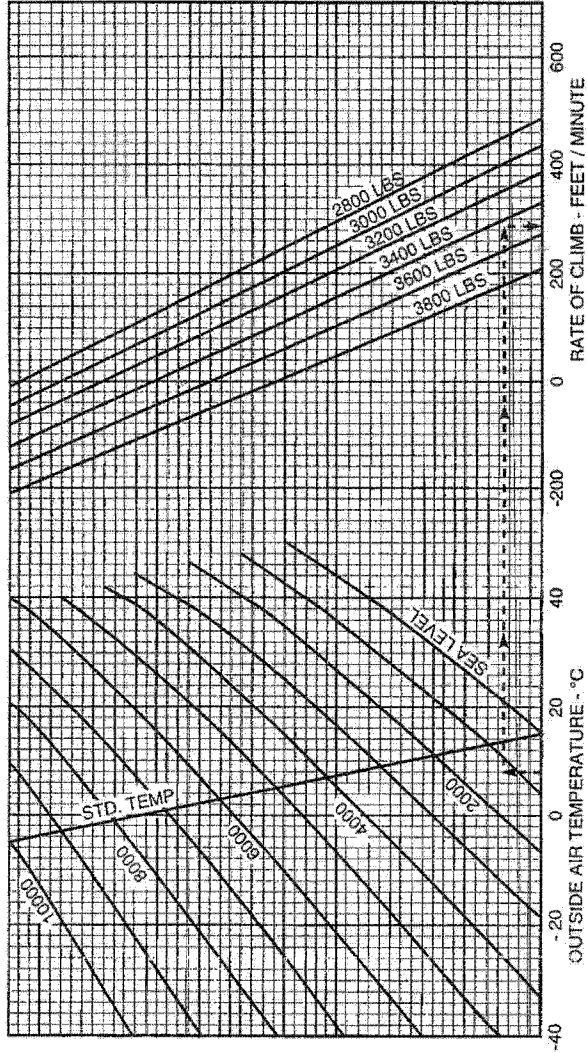

CLIMB PERFORMANCE - ONE ENGINE OPERATING - GEAR UP

Figure 5-19

FUEL, TIME AND DISTANCE TO CLIMB

ASSOCIATED CONDITIONS:

Wing Flaps: 0°
 Cowl Flaps: OPEN
 Landing Gear: UP
 Power: 2700 RPM &
 FULL THROTTLE

Climb Speed: 88 KIAS
 Wind: NONE

EXAMPLE:

Departure Airport O.A.T.: 8°C
 Dep. Airport Press. Alt.: 1250 FT
 Cruise O.A.T.: 2°C
 Cruise Press. Alt.: 5500 FT

Fuel to Climb: 2.6-0.4=2.2 GAL
 Time to Climb: 4.5-0.9=3.6 MIN
 Distance to Climb: 7.3-1.4=5.9 N.M.

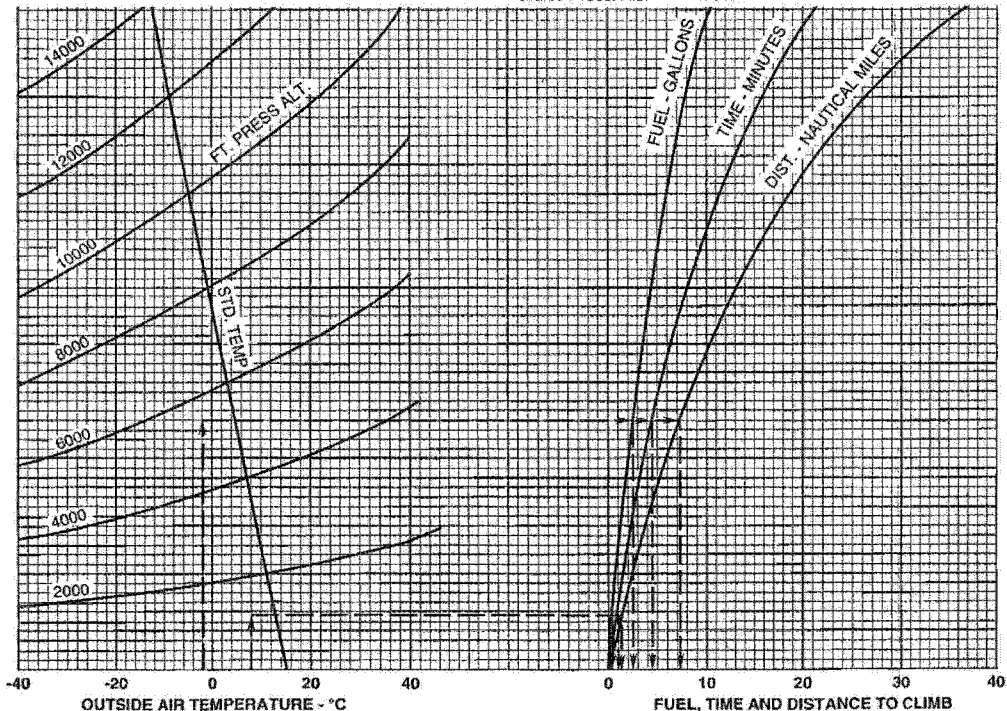

FUEL, TIME AND DISTANCE TO CLIMB

Figure 5-21

FUEL AND POWER SETTING TABLE
LYCOMING (L) O-360-A1H6 (PER ENGINE)

Press. Alt. Feet	Std. Alt. Temp. °C	99 BHP- 55% Rated Power Approx. Fuel Flow 8.7 G.P.H.* RPM AND MAN. PRESS.				117 BHP- 65% Rated Power Approx. Fuel Flow 10.2 G.P.H.* RPM AND MAN. PRESS.				135 BHP- 75% Rated Power Approx. Fuel Flow 11.7 G.P.H.* RPM AND MAN. PRESS.				Press. Alt. Feet
		2100	2200	2300	2400	2100	2200	2300	2400	2200	2300	2400	2500	
SL	15	22.3	21.7	21.1	20.6	24.9	24.2	23.5	22.9	26.7	26.0	25.2	24.6	SL
1000	13	22.0	21.3	20.8	20.3	24.6	23.8	23.2	22.6	26.3	25.6	24.9	24.3	1000
2000	11	21.7	21.0	20.5	20.0	24.2	23.5	22.9	22.3	25.9	25.3	24.6	24.0	2000
3000	9	21.3	20.7	20.2	19.8	23.9	23.2	22.6	22.0	25.6	25.0	24.4	23.7	3000
4000	7	21.1	20.5	20.0	19.5	23.5	22.8	22.3	21.8	FT	24.7	24.1	23.5	4000
5000	5	20.8	20.2	19.7	19.2	23.2	22.5	22.0	21.5	—	FT	23.8	23.2	5000
6000	3	20.5	19.9	19.4	19.0	22.9	22.2	21.7	21.3	—	—	FT	22.9	6000
7000	1	20.2	19.7	19.2	18.7	FT	21.9	21.5	21.0	—	—	—	FT	7000
8000	-1	20.0	19.4	18.9	18.5	—	FT	21.2	20.8					8000
9000	-3	19.7	19.1	18.7	18.2	—	—	FT	20.6					9000
10,000	-5	19.5	18.9	18.4	18.0	—	—	—	FT					10,000
11,000	-7	19.2	18.7	18.2	17.8									11,000
12,000	-9	FT	18.4	18.0	17.6									12,000
13,000	-11	—	FT	FT	17.4									13,000
14,000	-13	—	—	—	FT									14,000

NOTE: To maintain constant power, add approximately 1% Manifold Pressure for each 8°C above standard. Subtract approximately 1% for each 8°C below standard.

*PERFORMANCE CRUISE POWER

FUEL & POWER SETTING TABLE
Figure 5-23

SPEED POWER

ASSOCIATED CONDITIONS:
 Cowl Flaps: CLOSED
 Landing Gear: UP
 Wing Flaps: 0°
 Mid Cruise Weight: 3480 LBS

APPROX. FUEL FLOW		%
PERF. CRUISE	ECON CRUISE	POWER
17.4 GPH	14.0 GPH	55
20.4 GPH	16.6 GPH	65
23.3 GPH	19.2 GPH	75

EXAMPLE:
 Cruise OAT: -2°C
 Cruise pressure altitude: 5500 FT
 Cruise power: 55 %
 Cruise speed: 140 KTAS

SPEED POWER
Figure 5-25

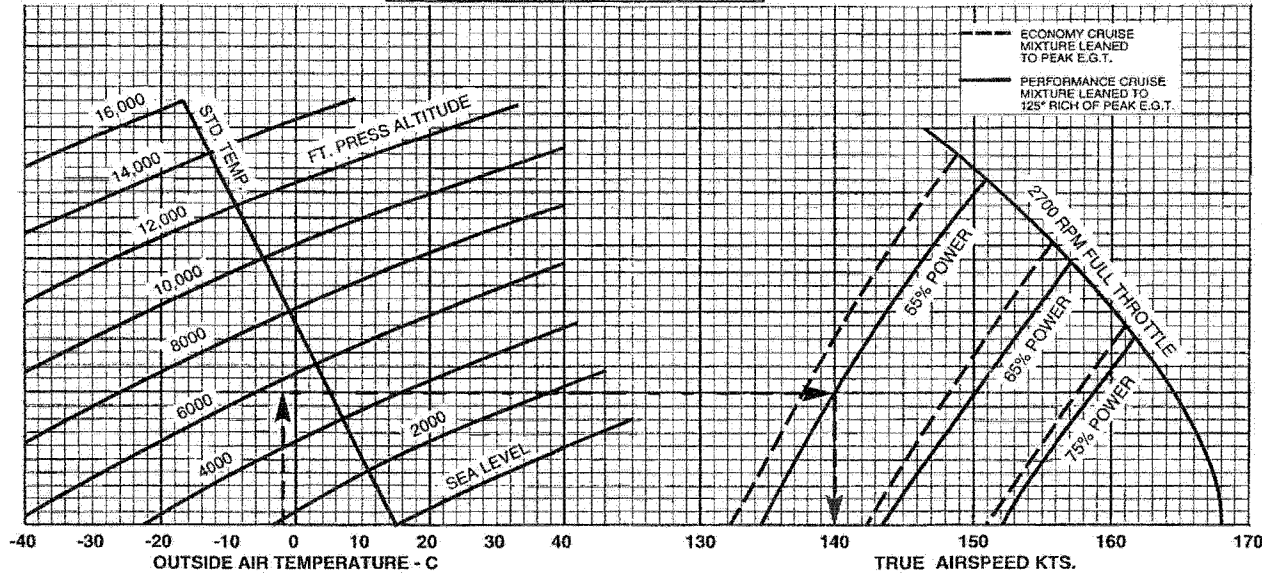

THIS PAGE INTENTIONALLY LEFT BLANK

STANDARD TEMPERATURE RANGE AND ENDURANCE - PERFORMANCE CRUISE

ASSOCIATED CONDITIONS:
 Usable Fuel: 108 G.A.L.
 Weight: 3800 LBS
 Landing Gear: UP
 Cowl Flaps: CLOSED
 Wing Flaps: 0°

Wind: NONE
 Mixtures: LEANED TO 125°F RICH OF PEAK EG

EXAMPLE:
 Cruise Altitude: 5,600 FT
 Power: 55%
 Range w/45 Min. Reserve: 741 N.M.
 Endurance w/45 Min. Reserve: 5.25 HRS.

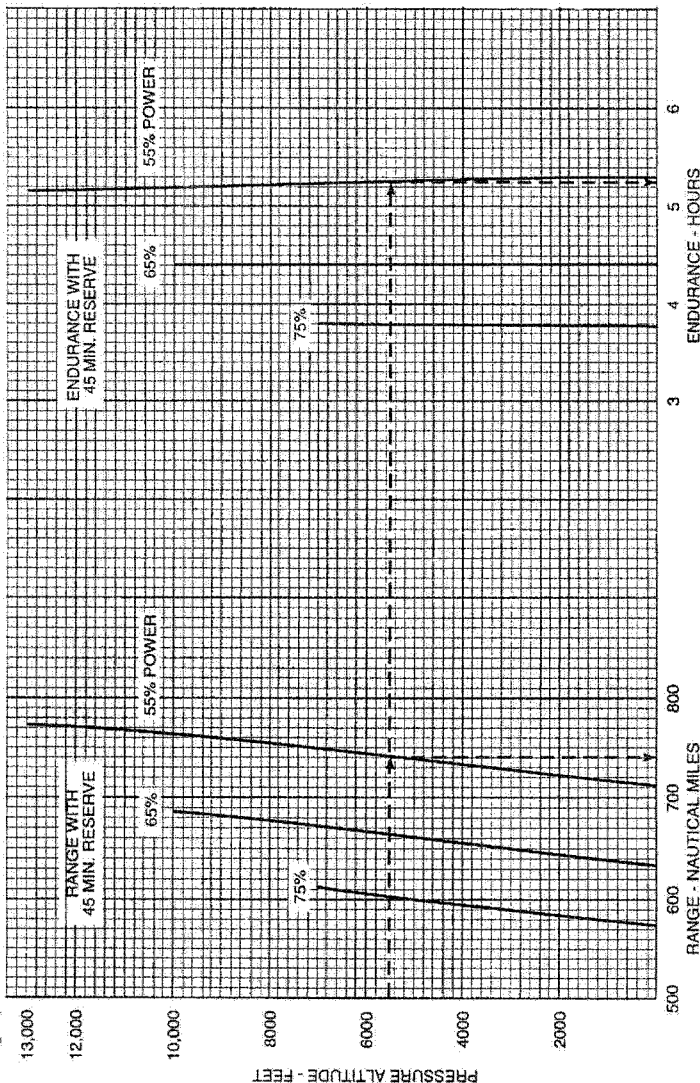

STANDARD TEMPERATURE RANGE AND ENDURANCE - PERFORMANCE CRUISE

Figure 5-27

THIS PAGE INTENTIONALLY LEFT BLANK

STANDARD TEMPERATURE RANGE AND ENDURANCE - ECONOMY CRUISE

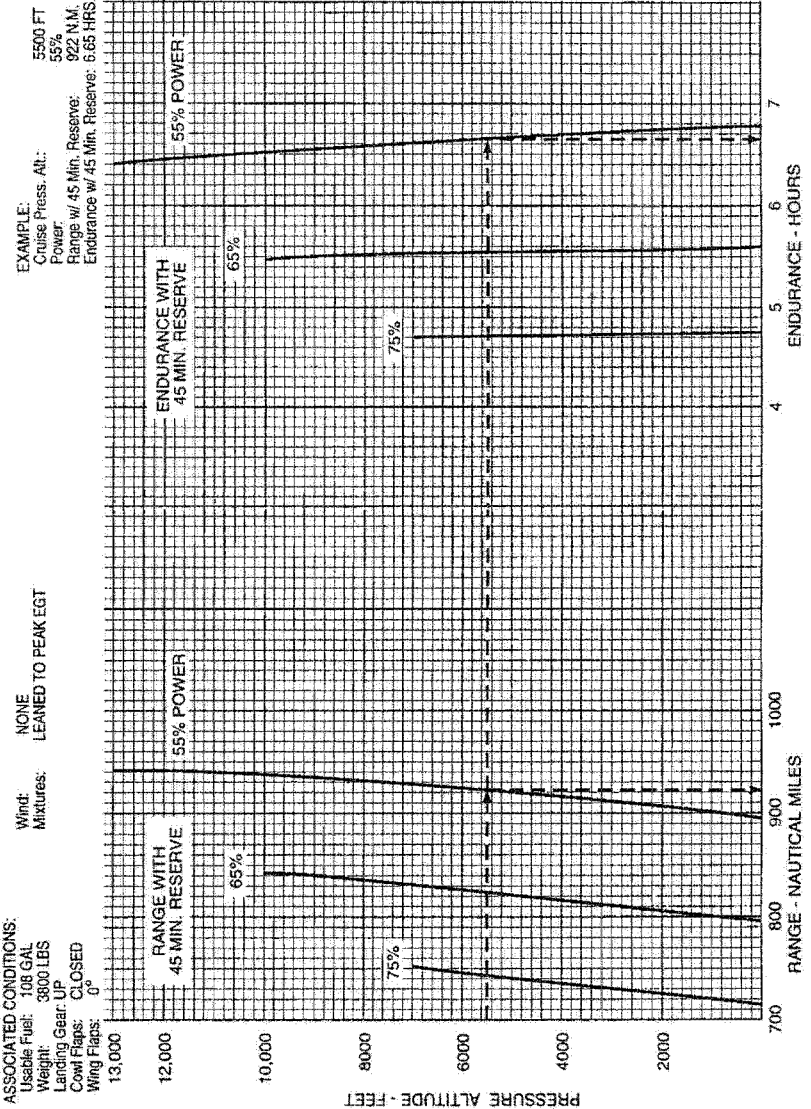

STANDARD TEMPERATURE RANGE AND ENDURANCE - ECONOMY CRUISE

Figure 5-29

FUEL, TIME AND DISTANCE TO DESCEND

ASSOCIATED CONDITIONS:

Airspeed: 165 KIAS
 Descent: 500 FPM
 Both Engines: 2400 RPM &
 THROTTLE AS REQUIRED
 TO MAINTAIN AIRSPEED
 AND DESCENT RATE

Wing Flaps: 0°
 Cowl Flaps: CLOSED
 Landing Gear: UP
 Wind: NONE

EXAMPLE:

Cruise O.A.T.: -2°C
 Cruise Altitude: 5500 FT
 Destination Airport O.A.T.: 8°C
 Destination Airport Altitude: 680 FT

Fuel to Descend: 3 - 1 = 2 GAL
 Time to Descend: 9 - 2 = 7 MIN
 Distance to Descend: 30 - 4 = 26 N.M.

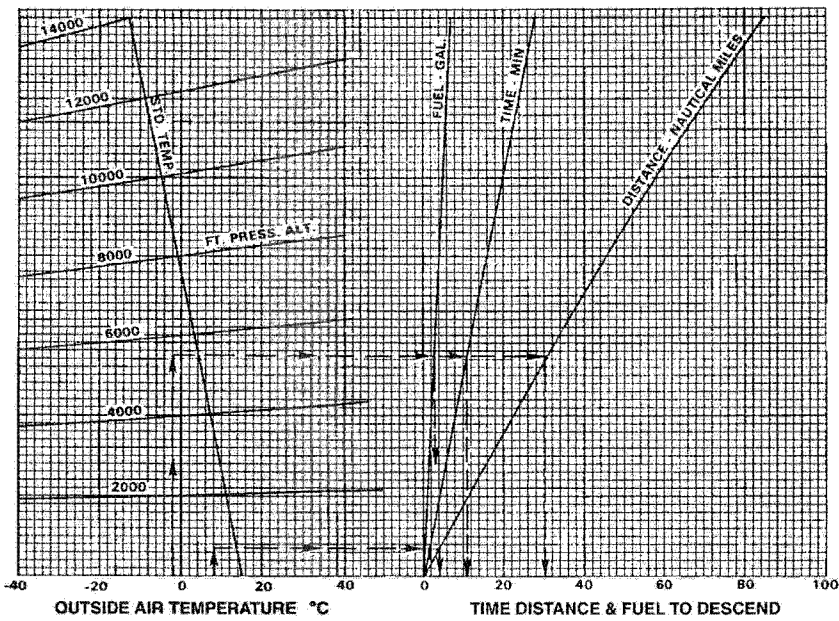

FUEL, TIME AND DISTANCE TO DESCEND

Figure 5-31

LANDING DISTANCE OVER 50 FT OBSTACLE — SHORT FIELD EFFORT

ASSOCIATED CONDITIONS:

Wing Flaps: 40°
 Power: OFF
 Cowl Flaps: AS REQUIRED
 Runway: PAVED LEVEL & DRY
 Touchdown: FULL STALL
 Approach Speed: AS SCHEDULED

EXAMPLE:

O.A.T.: 6°
 Press. Alt.: 680 FT
 Weight: 3107 LBS
 Wind Component: 5 KT HEADWIND

Approach Speed: 68 KIAS
 Total Landing Distance: 1238 FT

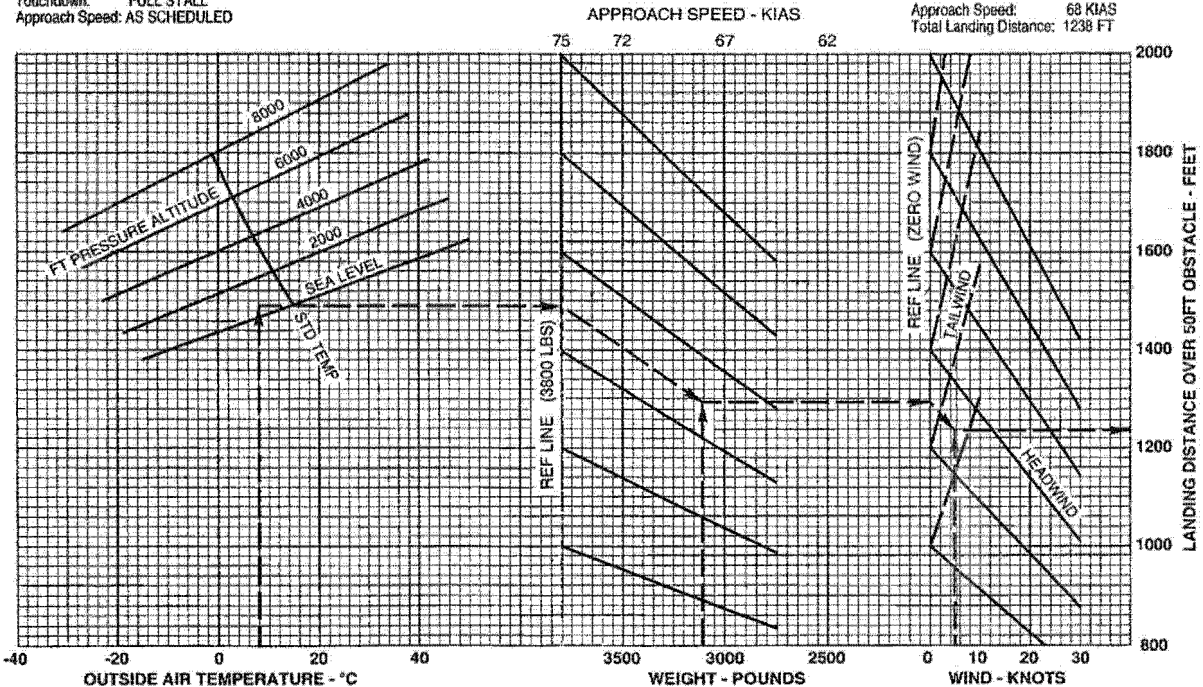

LANDING DISTANCE OVER 50 FT. OBSTACLE - SHORT FIELD EFFORT

Figure 5-33

LANDING GROUND ROLL — SHORT FIELD EFFORT

EXAMPLE:
O.A.T.: 8°
Pressure Altitude: 660 FT
Weight: 3107 LBS
Wind Component: 5 KT HEADWIND
Landing Ground Roll: 542 FT

ASSOCIATED CONDITIONS:
Wing Flaps: 40°
Power: OFF
Cowl Flaps: OPEN
Runway: PAVED LEVEL & DRY
Touchdown: FULL STALL

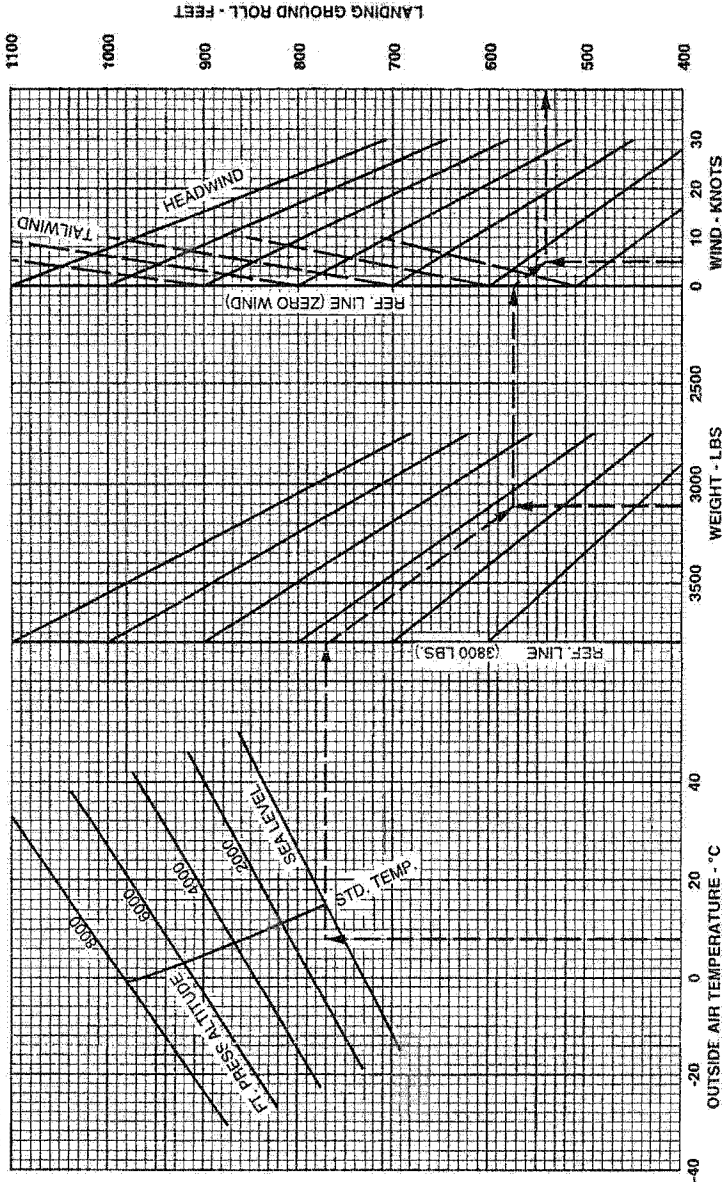

LANDING GROUND ROLL - SHORT FIELD EFFORT

Figure 5-35

TABLE OF CONTENTS
SECTION 6
WEIGHT AND BALANCE

Paragraph No.	Page No.
6.1 General.....	6-1
6.3 Airplane Weighing Procedure.....	6-2
6.5 Weight and Balance Data Record.....	6-5
6.7 Weight and Balance Determination for Flight.....	6-9
6.9 Instructions for Using the Weight and Balance Plotter.....	6-15

THIS PAGE INTENTIONALLY LEFT BLANK

**SECTION 6
WEIGHT AND BALANCE****6.1 GENERAL**

In order to achieve the performance and flying characteristics which are designed into the airplane, it must be flown with the weight and center of gravity (C.G.) position within the approved operating range (envelope). Although the airplane offers flexibility of loading, it cannot be flown with the maximum number of adult passengers, full fuel tanks and maximum baggage. With the flexibility comes responsibility. The pilot must ensure that the airplane is loaded within the loading envelope before he makes a takeoff.

Misloading carries consequences for any aircraft. An overloaded airplane will not take off, climb or cruise as well as a properly loaded one. The heavier the airplane is loaded, the less climb performance it will have.

Center of gravity is a determining factor in flight characteristics. If the C.G. is too far forward in any airplane, it may be difficult to rotate for takeoff or landing. If the C.G. is too far aft, the airplane may rotate prematurely on takeoff or tend to pitch up during climb. Longitudinal stability will be reduced. This can lead to inadvertent stalls and even spins; and spin recovery becomes more difficult as the center of gravity moves aft of the approved limit.

A properly loaded airplane, however, will perform as intended. This airplane is designed to provide performance within the flight envelope. Before the airplane is delivered, it is weighed, and a basic empty weight and C.G. location is computed (basic empty weight consists of the standard empty weight of the airplane plus the optional equipment). Using the basic empty weight and C.G. location, the pilot can determine the weight and C.G. position for the loaded airplane by computing the total weight and moment and then determining whether they are within the approved envelope.

6.1 GENERAL (Continued)

The basic empty weight and C.G. location are recorded in the Weight and Balance Data Form (Figure 6-5) and the Weight and Balance Record (Figure 6-7). The current values should always be used. Whenever new equipment is added or any modification work is done, the mechanic responsible for the work is required to compute a new basic empty weight and C.G. position and to write these in the Aircraft Log Book and the Weight and Balance Record. The owner should make sure that it is done.

A weight and balance calculation is necessary in determining how much fuel or baggage can be boarded so as to keep within allowable limits. Check calculations prior to adding fuel to ensure against overloading.

The following pages are forms used in weighing an airplane in production and in computing basic empty weight, C.G. position, and useful load. Note that the useful load includes usable fuel, baggage, cargo and passengers. Following this is the method for computing takeoff weight and C.G.

6.3 AIRPLANE WEIGHING PROCEDURE

At the time of licensing, provides each airplane with the basic empty weight and center of gravity location. This data is supplied by Figure 6-5.

The removal or addition of equipment or airplane modifications can affect the basic empty weight and center of gravity. The following is a weighing procedure to determine this basic empty weight and center of gravity location:

(a) Preparation

- (1) Be certain that all items checked in the airplane equipment list are installed in the proper location in the airplane.
- (2) Remove excessive dirt, grease, moisture, and foreign items such as rags and tools, from the airplane before weighing.
- (3) Defuel airplane. Then open all fuel drains until all remaining fuel is drained. Operate each engine until all undrainable fuel is used and engine stops. Then add the unusable fuel (2.0 gallons total, 1.0 gallon each wing).

6.3 AIRPLANE WEIGHING PROCEDURE (Continued)

CAUTION

Whenever the fuel system is completely drained and fuel is replenished it will be necessary to run the engines for a minimum of 3 minutes at 1000 RPM on each tank to ensure no air exists in the fuel supply lines.

- (4) Fill with oil to full capacity.
- (5) Place pilot and copilot seats in fourth (4th) notch, aft of forward position. Put flaps in the fully retracted position and all control surfaces in the neutral position. Tow bar should be in the proper location and entrance and baggage door closed.
- (6) Weigh the airplane inside a closed building to prevent errors in scale readings due to wind.

(b) Leveling

- (1) With airplane on scales, block main gear oleo pistons in the fully extended position.
- (2) Level airplane (refer to Figure 6-3) deflating nose wheel tire, to center bubble on level.

(c) Weighing- Airplane Basic Empty Weight

- (1) With the airplane level and brakes released, record the weight shown on each scale. Deduct the tare, if any, from each reading.

Scale Position and Symbol	Scale Reading	Tare	Net Weight
Nose Wheel (N)			
Right Main Wheel (R)			
Left Main Wheel (L)			
Basic Empty Weight, (as Weighed) (T)			

WEIGHING FORM

Figure 6-1

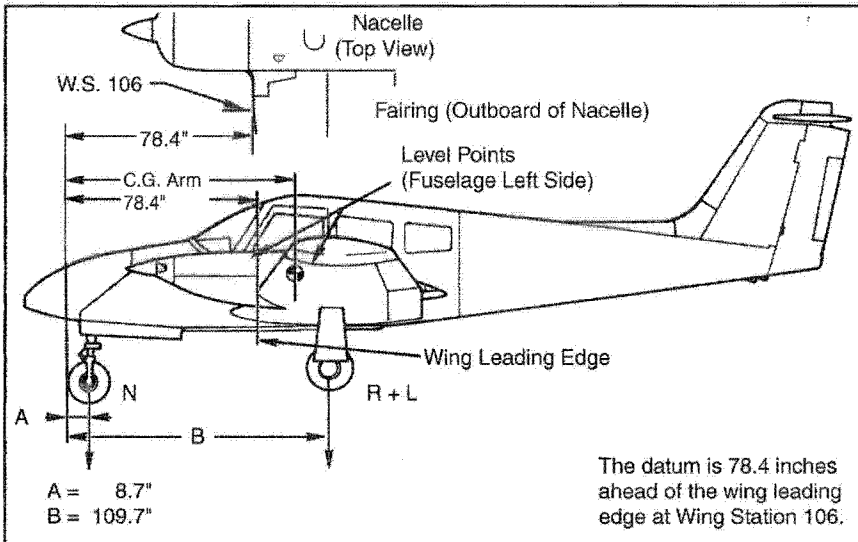

LEVELING DIAGRAM

Figure 6-3

6.3 AIRPLANE WEIGHING PROCEDURE (Continued)

(d) Basic Empty Weight Center of Gravity

- (1) The Leveling Diagram geometry (Figure 6-3) applies to the PA-44-180 airplane when it is level. Refer to Leveling paragraph 6.3 (b).
- (2) The basic empty weight center of gravity (as weighed including optional equipment, full oil and unusable fuel) can be determined by the following formula:

$$\text{C.G. Arm} = \frac{N(A) + (R+L)(B)}{T} \quad \text{inches}$$

$$\text{Where: } T = N + R + L$$

6.5 WEIGHT AND BALANCE DATA AND RECORD

The Basic Empty Weight, Center of Gravity Location and Useful Load listed in Figure 6-5 are for the airplane as delivered from the factory. These figures apply only to the specific airplane serial number and registration number shown.

The basic empty weight of the airplane as delivered from the factory has been entered in the Weight and Balance Record (Figure 6-7). This form is provided to present the current status of the airplane basic empty weight and a complete history of previous modifications. Any change to the permanently installed equipment or modification which affects weight or moment must be entered in the Weight and Balance Record.

MODEL PA-44-180, SEMINOLE

Airplane Serial Number **4496244**
 Registration Number **N756A**
 Date **10/18/07**

AIRPLANE BASIC EMPTY WEIGHT

Item	Weight (Lbs)	x C.G. Arm (Inches Aft of Datum)	= Moment (In-Lbs)
Standard Empty Weight* Computed Actual	2609.9	85.8519	224065.0
Optional Equipment	23.4	101.9188	2384.9
Basic Empty Weight	2633.3	85.9947	226449.9

*The standard empty weight includes full oil capacity and 2.0 gallons of unusable fuel.

AIRPLANE USEFUL LOAD - NORMAL CATEGORY OPERATION

$(\text{Gross Weight}) - (\text{Basic Empty Weight}) = \text{Useful Load}$

$(3800 \text{ lbs.}) - (2633.3 \text{ lbs.}) = 1166.7 \text{ lbs.}$

THIS BASIC EMPTY WEIGHT, C.G. AND USEFUL LOAD ARE FOR THE AIRPLANE AS LICENSED AT THE FACTORY. REFER TO APPROPRIATE AIRCRAFT RECORD WHEN ALTERATIONS HAVE BEEN MADE.

WEIGHT AND BALANCE DATA FORM

Figure 6-5

PA-44-180		Serial Number 4496244		Registration Number N756A			Page Number	
Date	Item No.	Description of Article or Modification	Added (+) Removed (-)	Weight Change			Running Basic Empty Weight	
				Wt. (Lb.)	Arm (In.)	Moment /100	Wt. (Lb.)	Moment /100
10/18/07		As Delivered					2633.3	

WEIGHT AND BALANCE RECORD

Figure 6-7

ISSUED: JULY 12, 1995

REPORT: VB-1616

6-7

SECTION 6

WEIGHT AND BALANCE

PA-44-180, SEMINOLE

PA-44-180	Date	Item No.	Serial Number		Added (+) Removed (-)	Registration Number			Page Number		
						Description of Article or Modification	Wt. (Lb.)	Arm (In.)	Moment /100	Weight Change	

WEIGHT AND BALANCE RECORD (Continued)

Figure 6-7 (Continued)

6.7 WEIGHT AND BALANCE DETERMINATION FOR FLIGHT

- (a) Add the weight of all items to be loaded to the basic empty weight.
- (b) Use the Loading Graph (Figure 6-13) to determine the moment of all items to be carried in the airplane.
- (c) Add the moment of all items to be loaded to the basic empty weight moment.
- (d) Divide the total moment by the total weight to determine the C.G. location.
- (e) By using the figures of item (a) and item (d) (above), locate a point on the C.G. range and weight graph (Figure 6-15). If the point falls within the C.G. envelope, the loading meets the weight and balance requirements.

6.7 WEIGHT AND BALANCE DETERMINATION FOR FLIGHT
(Continued)

	Weight (Lbs)	Arm Aft Datum (Inches)	Moment (In-Lbs)
Basic Empty Weight			
Pilot and Front Passenger	340.0	80.5	27370
Passengers (Rear Seats)	340.0	118.1	40154
Fuel (108 Gallon Maximum Usable)		95.0	
Baggage (200 Lb. Limit)		142.8	
Ramp Weight (3816 Lbs. Max.)			
Fuel Allowance for Engine Start, Taxi & Runup	-16.0	95.0	-1520
Take-off Weight (3800 Lbs. Max.)			

The center of gravity (C.G.) for the take-off weight of this sample loading problem is at _____ inches aft of the datum line. Locate this point () on the C.G. range and weight graph. Since this point falls within the weight - C.G. envelope, this loading meets the weight and balance requirements.

Take-off Weight			
Minus Estimated Fuel Burn-off (climb & cruise) @ 6.0 Lbs/Gal.		95.0	
Landing Weight			

Locate the center of gravity of the landing weight on the C.G. range and weight graph. Since this point falls within the weight- C.G. envelope, the loading may be assumed acceptable for landing.

IT IS THE RESPONSIBILITY OF THE PILOT AND AIRCRAFT OWNER TO ENSURE THAT THE AIRPLANE IS LOADED PROPERLY AT ALL TIMES.

SAMPLE LOADING PROBLEM

Figure 6-9

6.7 WEIGHT AND BALANCE DETERMINATION FOR FLIGHT (Continued)

	Weight (Lbs)	Arm Aft Datum (Inches)	Moment (In-Lbs)
Basic Empty Weight			
Pilot and Front Passenger		80.5	
Passengers (Rear Seats)		118.1	
Fuel (108 Gallon Maximum Usable)		95.0	
Baggage (200 Lb. Limit)		142.8	
Ramp Weight (3816 Lbs. Max.)			
Fuel Allowance for Engine Start, Taxi & Runup	-16.0	95.0	-1520
Take-off Weight (3800 Lbs. Max.)			

The center of gravity (C.G.) for the take-off weight of this loading problem is at _____ inches aft of the datum line. Locate this point () on the C.G. range and weight graph. If this point falls within the weight - C.G. envelope, this loading meets the weight and balance requirements.

Take-off Weight			
Minus Estimated Fuel Burn-off (climb & cruise) @ 6.0 Lbs/Gal.		95.0	
Landing Weight			

Locate the center of gravity of the landing weight on the C.G. range and weight graph. If this point falls within the weight- C.G. envelope, the loading may be assumed acceptable for landing.

IT IS THE RESPONSIBILITY OF THE PILOT AND AIRCRAFT OWNER TO ENSURE THAT THE AIRPLANE IS LOADED PROPERLY AT ALL TIMES.

WEIGHT AND BALANCE LOADING FORM

Figure 6-11

THIS PAGE INTENTIONALLY LEFT BLANK

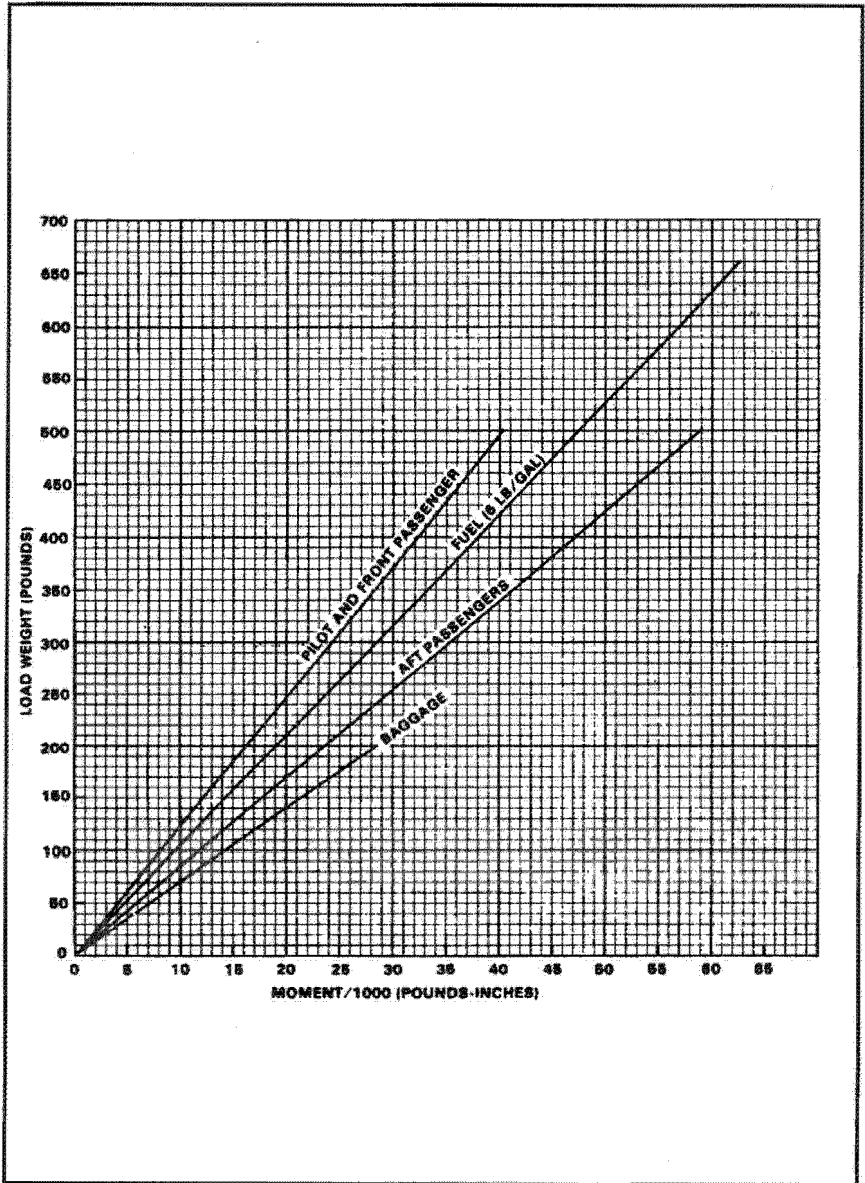

LOADING GRAPH

Figure 6-13

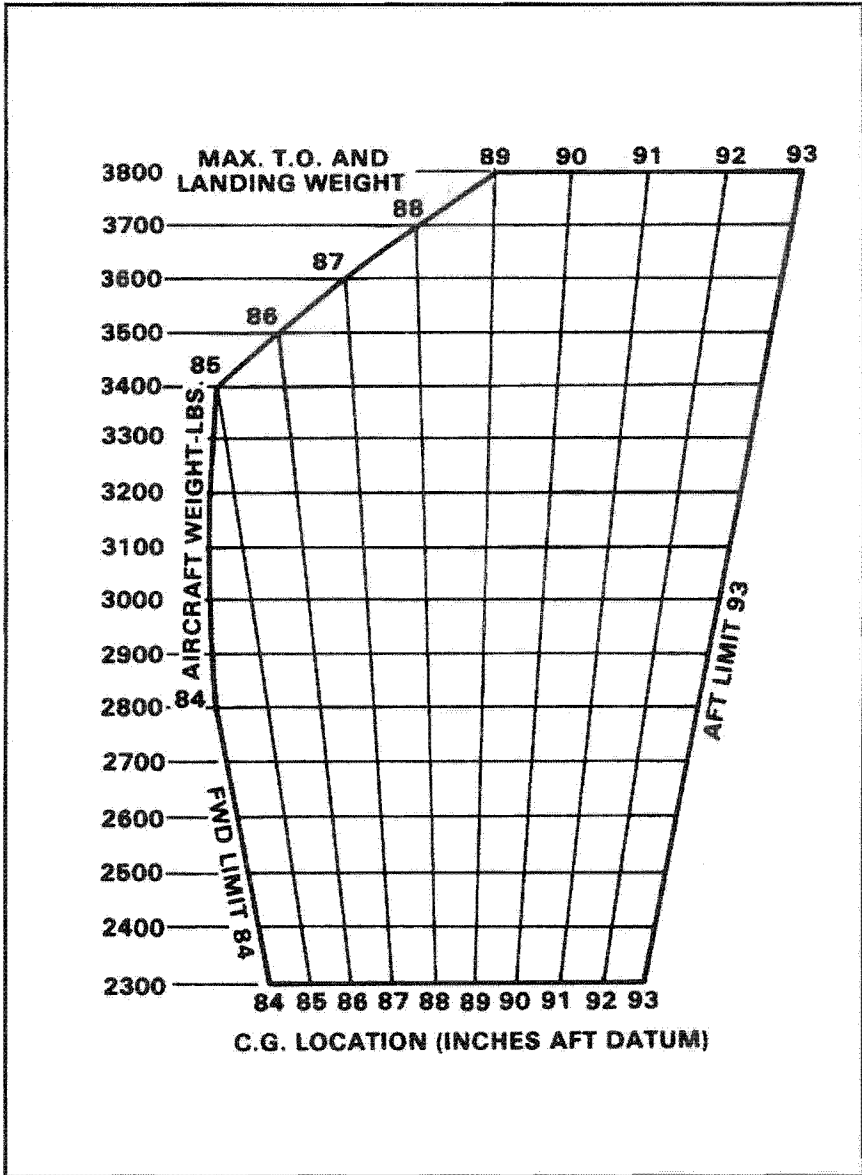

C.G. RANGE AND WEIGHT

Figure 6-15

6.9 INSTRUCTIONS FOR USING THE WEIGHT AND BALANCE PLOTTER

This plotter is provided to enable the pilot quickly and conveniently to:

- (a) Determine the total weight and C.G. position.
- (b) Decide how to change his load if his first loading is not within the allowable envelope.

Heat can warp or ruin the plotter if it is left in the sunlight. Replacement plotters may be purchased from Piper dealers and distributors.

When the airplane is delivered, the basic weight and basic C.G. will be recorded on the computer. These should be changed any time the basic weight or C.G. location is changed.

The plotter enables the user to add weights and corresponding moments graphically. The effect of adding or disposing of useful load can easily be seen. The plotter does not cover the situation where cargo is loaded in locations other than on the seats or in the baggage compartments.

Brief instructions are given on the plotter itself. To use it, first plot a point on the grid to locate the basic weight and C.G. location. This can be put on more or less permanently because it will not change until the airplane is modified. Next, position the zero weight end of any one of the loading slots over this point. Using a pencil, draw a line along the slot to the weight which will be carried in that location. Then position the zero weight end of the next slot over the end of this line and draw another line representing the weight which will be located in this second position. When all the loads have been drawn in this manner, the final end of the segmented line locates the total load and the C.G. position of the airplane for takeoff. If this point is not within the allowable envelope it will be necessary to remove fuel, baggage, or passengers and/or to rearrange baggage and passengers to get the final point to fall within the envelope.

Fuel burn-off and gear movement do not significantly affect the center of gravity.

SAMPLE PROBLEM

A sample problem (Figure 6-17) will demonstrate the use of the weight and balance plotter.

Assume a basic weight and C.G. location of 2364 pounds at 86.14 inches respectively. We wish to carry a pilot and 3 passengers. Two men weighing 180 and 200 pounds will occupy the front seats, and two children weighing 80 and 100 pounds will ride in the rear. Two suitcases weighing 25 pounds and 20 pounds respectively, will be carried in the rear compartment. We wish to carry 60 gallons of fuel. Will we be within the safe envelope?

- (a) Place a dot on the plotter grid at 2364 pounds and 86.14 inches to represent the basic airplane. (See illustration.)
- (b) Slide the slotted plastic into position so that the dot is under the slot for the forward seats, at zero weight.
- (c) Draw a line up the slot to the 380 pound position (180 + 200) and put a dot.
- (d) Continue moving the plastic and plotting points to account for weight in the rear seats (80 + 100), baggage compartment (45), and fuel tanks (360).
- (e) As can be seen from the illustration, the final dot shows the total weight to be 3329 pounds with the C.G. at 89.30. This is well within the envelope.
- (f) There will be room for more fuel.

As fuel is burned off, the weight and C.G. will follow down the fuel line and stay within the envelope for landing.

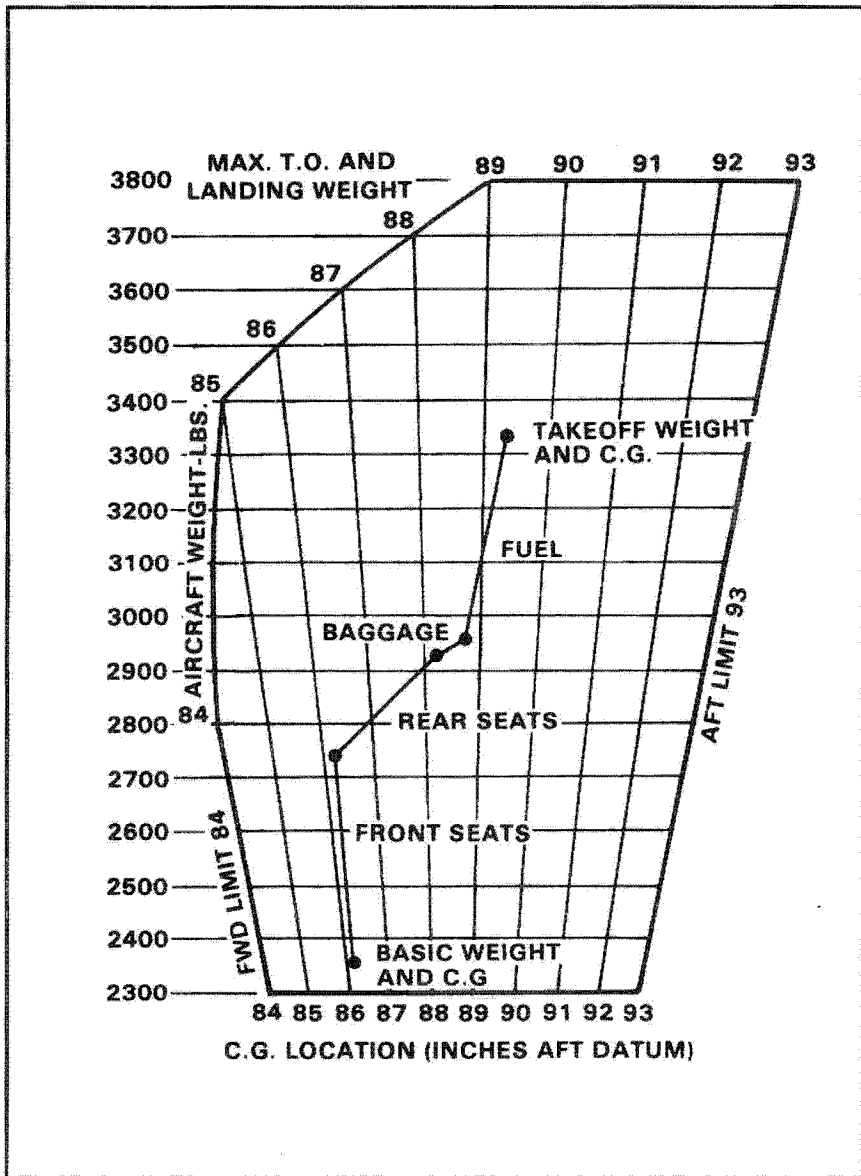

SAMPLE PROBLEM

Figure 6-17

THIS PAGE INTENTIONALLY LEFT BLANK

TABLE OF CONTENTS

SECTION 7

DESCRIPTION AND OPERATION
OF THE AIRPLANE AND IT'S SYSTEMS

Paragraph No.	Page No.
7.1 The Airplane	7-1
7.3 Airframe	7-1
7.5 Engines and Propellers.....	7-2
7.7 Engine Controls.....	7-5
7.9 Landing Gear.....	7-7
7.11 Brake System	7-14
7.13 Flight Control System	7-14
7.15 Fuel System.....	7-16
7.17 Electrical System.....	7-19
7.19 Vacuum System.....	7-26
7.21 Pitot Static System	7-28
7.23 Heating, Ventilating and Defrosting System.....	7-30
7.25 Instrument Panel.....	7-34
7.27 Cabin Features.....	7-38
7.29 Baggage Area.....	7-42
7.31 Finish.....	7-42

TABLE OF CONTENTS
SECTION 7
DESCRIPTION AND OPERATION
OF THE AIRPLANE AND IT'S SYSTEMS

Paragraph No.		Page No.
7.33	Stall Warning.....	7-42
7.35	Emergency Locator Transmitter.....	7-43

SECTION 7

DESCRIPTION AND OPERATION
OF THE AIRPLANE AND ITS SYSTEMS

7.1 THE AIRPLANE

The Seminole is a twin-engine, all metal, retractable landing gear, airplane. It has seating for up to four occupants and has a two hundred pound capacity luggage compartment.

7.3 AIRFRAME

With the exception of the steel engine mounts, the landing gear, the fiberglass nose cone, cowling nose bowls and tips of wings, and the ABS thermoplastic or fiberglass extremities (tail fin, rudder and stabilator), the basic airframe is of aluminum alloy. Aerobatics are prohibited in this airplane since the structure is not designed for aerobatic loads.

The fuselage is a semi-monocoque structure with a passenger door on the forward right side, a cargo door on the aft right side with an emergency egress door on the forward left side.

The wing is of a semi-tapered design and employs a modified laminar flow NACA airfoil section. The main spar is located at approximately 40% of the chord. The wings are attached to the fuselage by the insertion of the butt ends of the spar into a spar box carry-through, which is an integral part of the fuselage structure. The bolting of the spar ends into the spar box carry-through structure, which is located under the rear seats, provides in effect a continuous main spar. The wings are also attached fore and aft of the main spar by an auxiliary front spar and a rear spar. The rear spar, in addition to taking torque and drag loads, provides a mount for flaps and ailerons. The four-position wing flaps are mechanically controlled by a handle located between the front seats. When fully retracted, the right flap locks into place to provide a step for cabin entry. Each nacelle contains one fuel tank.

7.3 AIRFRAME (Continued)

A vertical stabilizer, an all-movable horizontal stabilator, and a rudder make up the empennage. The stabilator, which is mounted on top of the fin incorporates an anti-servo tab which provides longitudinal stability and trim. This tab moves in the same direction as the stabilator, but with increased travel. Rudder effectiveness is increased by an anti-servo tab on the rudder.

7.5 ENGINES AND PROPELLERS

ENGINES

The Seminole is powered by two Lycoming four-cylinder, direct drive, horizontally opposed engines, each rated at 180 horsepower @ 2700 RPM at sea level. The engines are air cooled and are equipped with oil coolers with low temperature bypass systems and engine-mounted oil filters. A winterization plate is provided to restrict air during winter operation. (See Winterization in Section 8.) Asymmetric thrust during takeoff and climb is eliminated by the counter-rotation of the engines: the left engine rotating in a clockwise direction when viewed from the cockpit, and the right engine rotating counterclockwise.

The engine oil dipstick is accessible through a door located on the upper cowl of each nacelle.

The engines are accessible through removable cowls. The upper cowl half is attached with quarter-turn fasteners and is removable. Engine mounts are constructed of steel tubing, and dynafocal engine mounts are provided to reduce vibration.

Induction Air System

The induction air box incorporates a manually operated two-way valve which allows the carburetor to receive either induction air which passes through the air filter or heated air which bypasses the filter. Carburetor heat selection provides heated air to the carburetor in the event of carburetor icing, and also allows selection of an alternate source of air in the event the induction air source or the air filter becomes blocked with ice, snow, freezing rain, etc. Carburetor heat selection provides air which is unfiltered; therefore, it should not be used during ground operation when dust or other contaminants might enter the system. The primary (through the filter) induction source should always be used for takeoffs.

7.5 ENGINES AND PROPELLERS (Continued)**PROPELLERS**

Counter-rotation of the propellers provides balanced thrust during takeoff and climb and eliminates the critical engine factor in single-engine flight.

Two blade, constant speed, controllable pitch and feathering Hartzell propellers are installed as standard equipment. The propellers mount directly to the engine crankshafts.

Pitch is controlled by oil and nitrogen pressure. Oil pressure sends a propeller toward the high RPM or unfeather position; nitrogen pressure and a large spring sends a propeller toward the low RPM or feather position and also prevents propeller overspeeding. The recommended nitrogen pressure to be used when charging the unit is listed on placards on the propeller domes and inside the spinners. This pressure varies with ambient temperature at the time of charging. Although dry nitrogen gas is recommended, compressed air may be used provided it contains no moisture. For more detailed instructions, see Propeller Service in Section 8 of this Handbook.

Governors, one on each engine, supply engine oil at various pressures through the propeller shafts to maintain constant RPM settings. A governor controls engine speed by varying the pitch of the propeller to match load torque to engine torque in response to changing flight conditions.

Each propeller is controlled by the propeller control levers located in the center of the power control quadrant. Feathering of a propeller is accomplished by moving the control fully aft through the low RPM detent, into the FEATHER position. Feathering takes place in approximately six seconds. Unfeathering is accomplished by moving the propeller control forward. This releases oil accumulated under pressure and moves the propeller out of the FEATHER position.

7.5 ENGINES AND PROPELLERS (Continued)

Unfeathering Accumulators

The propeller unfeathering system consists of increased capacity governors and gas charged accumulators.

The feathering governors are designed to operate in the conventional manner in addition to their accumulator unfeathering capability.

The accumulators store engine oil under pressure from the governors which is released back to the governors for propeller unfeathering when the propeller control lever is moved forward from the feathered position.

With this system installed the feathering time is 10 - 17 seconds and unfeathering times is 8 - 12 seconds depending on the oil temperature.

A feathering lock, operated by centrifugal force, prevents feathering during engine shutdown by making it impossible to feather any time the engine speed falls below 950 RPM. For this reason, when airborne, and the pilot wishes to feather a propeller to save an engine, he must be sure to move the propeller control into the FEATHER position before the engine speed drops below 950 RPM.

7.7 ENGINE CONTROLS

Engine controls consist of a throttle, a propeller control and a mixture control lever for each engine. These controls are located on the control quadrant on the lower center of the instrument panel where they are accessible to both the pilot and the copilot (Figure 7-1). The controls utilize teflon-lined control cables to reduce friction and binding.

The throttle levers are used to adjust the manifold pressure. Some aircraft incorporate gear up warning horn micro-switches which are activated by either or both throttles contacting the switches during the lower portion of throttle lever travel (approximately 14 in. Hg. MAP and below). If the landing gear is not locked down, the horn will sound until the gear is down and locked or until the power setting is increased. This is a safety feature to warn the pilot of an inadvertent gear up landing.

All throttle operations should be made with a smooth, not too rapid movement to prevent unnecessary engine wear or damage to the engines.

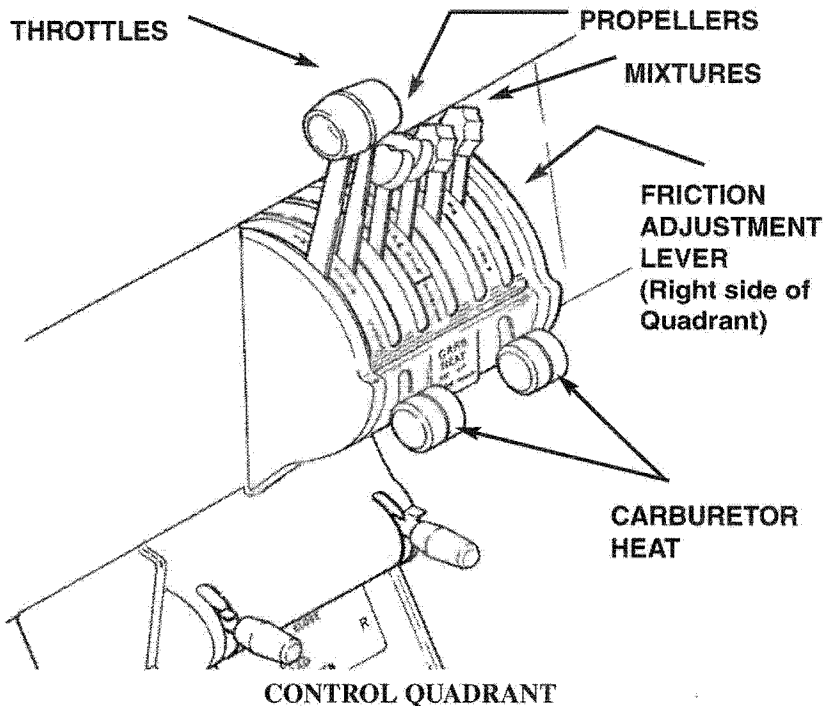

Figure 7-1

7.7 ENGINE CONTROLS (Continued)

The propeller control levers are used to adjust the propeller speed from high RPM (low pitch) to feather (high pitch).

The mixture control levers are used to adjust the air to fuel ratio. An engine is shut down by the placing of the mixture control lever in the full lean (idle cut-off) position.

The friction adjustment lever on the right side of the control quadrant may be adjusted to increase or decrease the friction holding the throttle, propeller, and mixture controls or to lock the controls in a selected position.

The carburetor heat controls are located on the control quadrant just below the engine control levers. When a carburetor heat lever is in the up, or OFF, position the engine is operating on filtered air; when the lever is in the down, or ON, position the engine is operating on unfiltered, heated air.

The cowl flap control levers (Figure 7-3), located below the control quadrant, are used to regulate cooling air for the engines. The levers have three positions: full open, full closed, and intermediate. A lock incorporated in each control lever locks the cowl flap in the selected position. To operate the cowl flaps, depress the lock and move the lever toward the desired setting. Release the lock after initial movement and continue movement of the lever. The control will stop and lock into place at the next setting. The lock must be depressed for each selection of a new cowl flap setting.

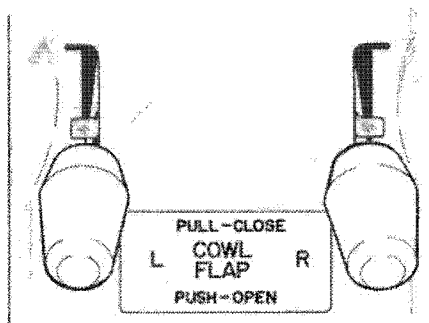

COWL FLAP CONTROLS

Figure 7-3

7.9 LANDING GEAR

The Seminole is equipped with hydraulically operated, fully retractable, tricycle landing gear. On takeoff, the gear should be retracted before an airspeed of 109 KIAS is exceeded. The landing gear may be lowered at any speed up to 140 KIAS.

NORMAL OPERATION

Hydraulic pressure for gear operation is furnished by an electrically powered, reversible hydraulic pump (refer to Figures 7-7 and 7-9). The pump is activated by a two-position gear selector switch located to the left of the control quadrant on the instrument panel (Figure 7-5). The gear selector switch which has a wheel-shaped knob must be pulled out before it is moved to the UP or DOWN position. When hydraulic pressure is exerted in one direction the gear is retracted; when it is exerted in the other direction the gear is extended. Gear extension or retraction normally takes six to seven seconds.

CAUTION

If the landing gear is in transit and the hydraulic pump is running it is NOT advisable to move the gear selector switch to the opposite position before the gear has reached its full travel limit, because a sudden reversal may damage the electric pump.

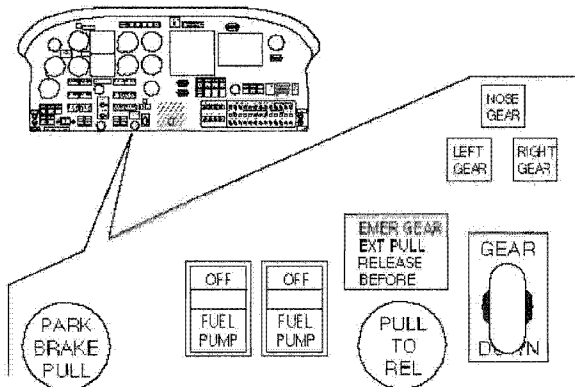

LANDING GEAR SELECTOR AND INDICATORS

Figure 7-5

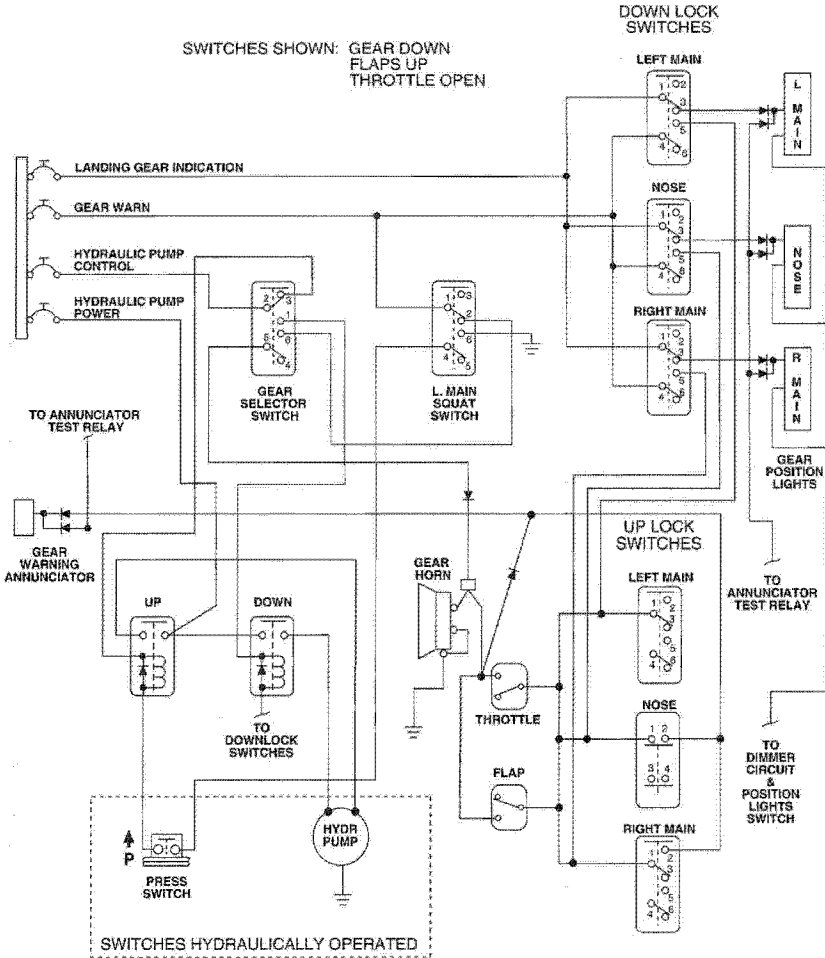

LANDING GEAR ELECTRICAL SYSTEM SCHEMATIC
(For aircraft with throttle mounted gear warning horn micro-switches)
Figure 7-7 (sheet 1 of 2)

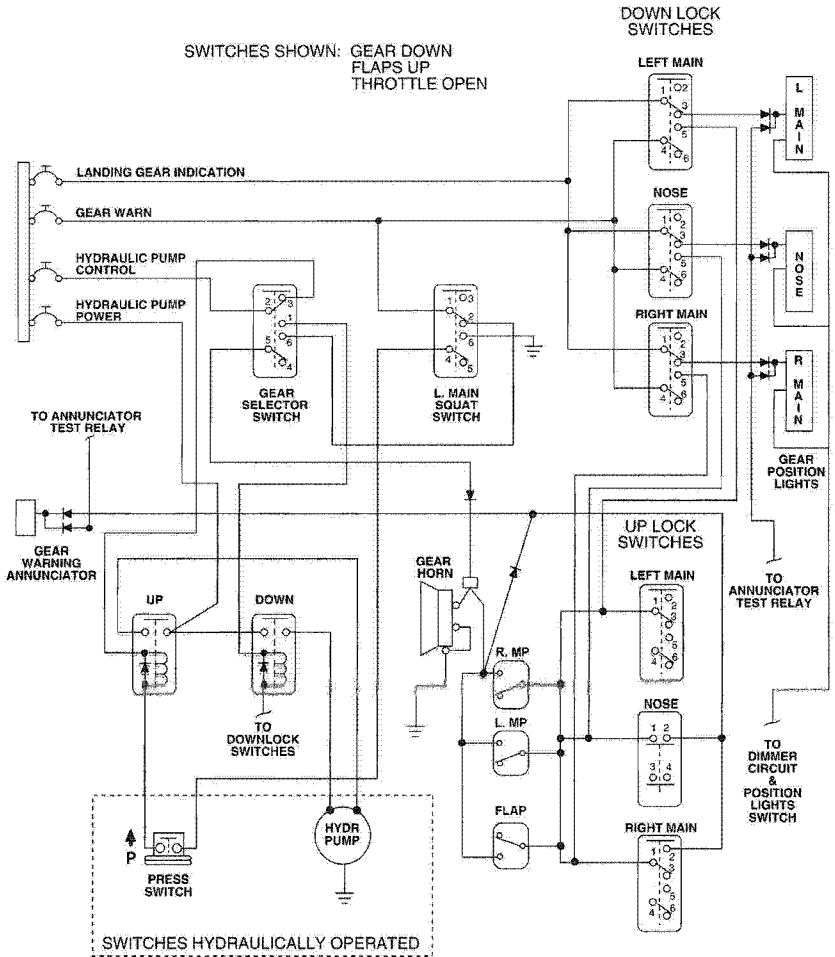

LANDING GEAR ELECTRICAL SYSTEM SCHEMATIC
 (For aircraft with engine mounted gear warning horn MAP switches)

Figure 7-7 (sheet 2 of 2)

THIS PAGE INTENTIONALLY LEFT BLANK

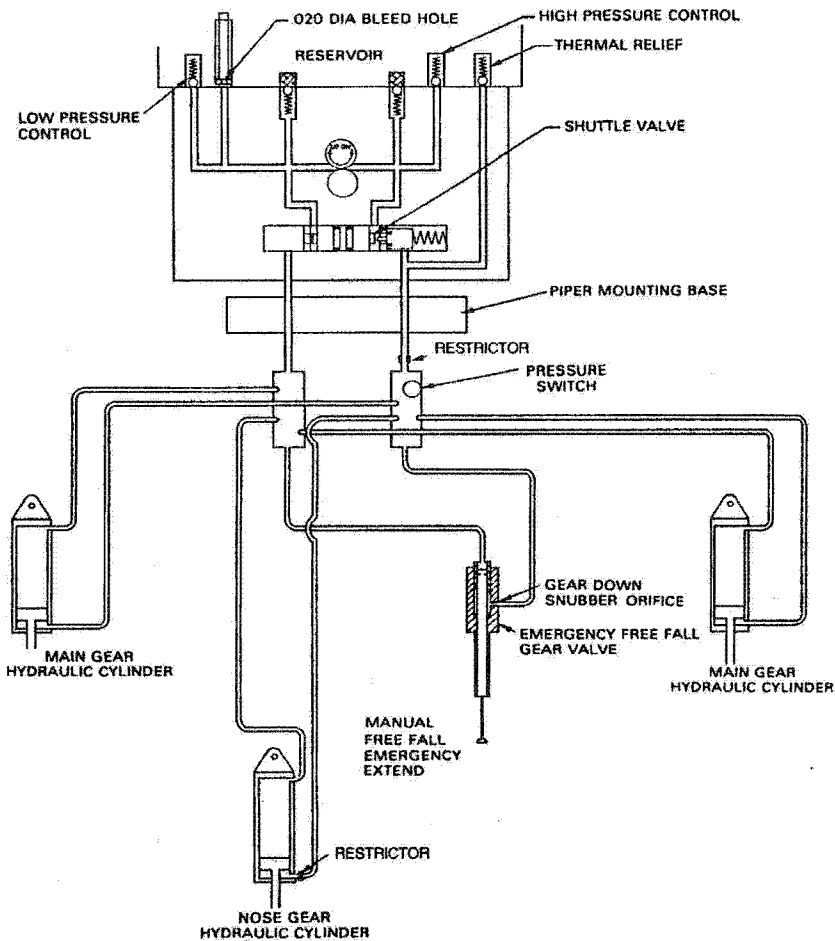

LANDING GEAR HYDRAULIC SYSTEM SCHEMATIC

Figure 7-9

7.9 LANDING GEAR (Continued)

When the gear is fully extended or fully retracted and the gear selector is in the corresponding position, electrical limit switches stop the flow of current to the motor of the hydraulic pump.

When the landing gear is retracted, the main wheels retract inboard into the wings and the nose wheel retracts aft into the nose section. Springs assist in gear extension and in locking the gear in the down position. After the gear are down and the downlock hooks engage, springs maintain force on each hook to keep it locked until it is released by hydraulic pressure.

A convex mirror on the left engine nacelle both serves as a taxiing aid and allows the pilot to visually confirm the condition of the nose gear.

ANNUNCIATOR LIGHTS

If the gear is in neither the full up nor the full down position, a red WARN GEAR UNSAFE annunciator (Figure 7-11) at the top left of the instrument panel illuminates.

The three green lights (Figure 7-11) directly above the landing gear selector switch illuminate to indicate that each of the three landing gears is down and locked.

The three green gear lights are dimmed automatically when the navigation lights are turned on. For this reason, if the navigation lights are turned on in the daytime, it is difficult to see the landing gear lights. If the green lights are not observed after placing the landing gear selector switch in the DOWN position, check the position of the navigation lights switch.

On aircraft equipped with a day/night dimmer switch, the switch must be in the DAY position to obtain full intensity of the gear position indicator lights during daytime flying. When the aircraft is operated at night, the day/night dimmer switch should be in the NIGHT position to dim the gear lights.

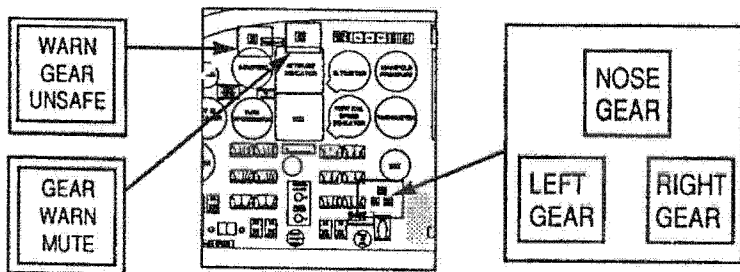

GEAR ANNUNCIATOR LIGHTS & MUTE SWITCH

Figure 7-11

ANNUNCIATOR LIGHTS (Continued)

If one or two of the three green lights do not illuminate when the gear DOWN position has been selected, any of the following conditions could exist for each light that is out:

- (a) The gear is not locked down.
- (b) A bulb is burned out.
- (c) There is a malfunction in the indicating system.

In order to check the bulbs, the square indicator lights can be pulled out and interchanged.

WARNING HORN

Should the throttle be placed in a low manifold pressure setting and/or the flaps are extended- as for a landing approach, while the gear is retracted, a warning horn sounds to alert the pilot that the gear is retracted. The gear warning horn emits a 90 cycles per minute beeping sound.

Some aircraft incorporate gear up warning horn micro-switches mounted in the throttle quadrant. Other aircraft incorporate gear up warning manifold pressure switches mounted on each engine. In either configuration, the gear warning horn will activate under the following conditions:

- (a) The gear is not locked down and the manifold pressure has fallen below 14 inches on either one or both engines.
- (b) The gear selector switch is in the UP position when the airplane is on the ground.
- (c) The gear selector switch is in the UP position and wing flaps are extended to the second or third notch position.

WARNING HORN MUTE SWITCH

A gear warning mute switch is located directly above the pilot's attitude indicator. Activating the mute switch will silence the gear warning horn only if the horn was triggered by power lever position. When activated, the mute switch will illuminate and the function may be cancelled by extending the landing gear or advancing the power lever(s).

7.9 LANDING GEAR (Continued)

SAFETY SWITCH

To prevent inadvertent gear retraction should the gear selector be placed in the UP position when the airplane is on the ground, a squat switch located on the left main gear will prevent the hydraulic pump from actuating if the master switch is turned on. On takeoff, when the landing gear oleo strut drops to its full extension, the safety switch closes to complete the circuit which allows the hydraulic pump to be activated to raise the landing gear when the gear selector is moved to the UP position. During the preflight check, be sure the landing gear selector is in the DOWN position and that the three green gear indicator lights are illuminated.

EMERGENCY EXTENSION

The landing gear is designed to extend even in the event of hydraulic failure. Since the gear is held in the retracted position by hydraulic pressure, should the hydraulic system fail for any reason, gravity will allow the gear to extend. To extend and lock the gears in the event of hydraulic failure, it is necessary only to relieve the hydraulic pressure.

An emergency gear extension knob, located below and to the left of the gear selector switch is provided for this purpose. A guard across the knob prevents inadvertent movement. Moving the guard aside and pulling the emergency gear extension knob releases the hydraulic pressure holding the gear in the up position and allows the gear to fall free. Before pulling the emergency gear extension knob, place the landing gear selector switch in the DOWN position to prevent the pump from trying to raise the gear.

NOTE

If the emergency gear knob has been pulled out to lower the gear by gravity due to a gear system malfunction, leave the control in its extended position until the airplane has been put on jacks to check the proper function of the landing gear hydraulic and electrical systems. See the Maintenance Manual for proper landing gear system check out procedures.

NOTE

If the airplane is being used for training purposes or a pilot check-out mission, and the emergency gear extension knob has been pulled out, it may be pushed in again when desired if there has not been any apparent malfunction of the landing gear system.

HYDRAULIC RESERVOIR

The hydraulic reservoir for landing gear operation is an integral part of the gear hydraulic pump. Access to the combination pump and reservoir is through a panel in the baggage compartment. For filling instructions, see the Maintenance Manual.

GROUND OPERATION

The nose gear is steerable through a 30 degree arc either side of center by use of a combination of full rudder pedal travel and brakes. A gear centering spring, incorporated in the nose gear steering system, prevents shimmy tendencies. A bungee assembly reduces ground steering effort and dampens shocks and bumps during taxiing. When the gear is retracted, the nose wheel centers as it enters the wheel well, and the steering linkage disengages to reduce pedal loads in flight.

TIRES

The main landing gear carries 6.00 x 6, 8-ply tires. The nose wheel has a 5.00 x 5, 6-ply tire. For information on servicing the tires, see TIRE INFLATION in Section 8 of this Handbook.

STRUTS

Struts for the landing gear are air-oil assemblies. Strut exposure should be checked during each preflight inspection. If a need for service or adjustment is indicated, refer to the instructions printed on the units. Should more detailed landing gear service information be required, refer to the Maintenance Manual.

7.11 BRAKE SYSTEM

NORMAL OPERATION

The brake system is designed to meet all normal braking needs. Two single-disc, double puck brake assemblies, one on each main gear, are actuated by toe brake pedals mounted on both the pilot's and copilot's rudder pedals. A brake system hydraulic reservoir, independent of the landing gear hydraulic reservoir, is located on the upper right side of the bulkhead in the nose compartment. Brake fluid should be maintained at the level marked on the reservoir. For further information see BRAKE SERVICE in Section 8 of this Handbook.

PARKING BRAKE

The parking brake is engaged by depressing the toe brake pedals and pulling out the parking brake knob located on the lower instrument panel below the left control column. The parking brake is released by depressing the toe brake pedals and pushing in the parking brake knob.

7.13 FLIGHT CONTROL SYSTEM

Dual flight controls are installed as standard equipment. The controls actuate the control surfaces through a cable system.

EMPENNAGE

The horizontal tail surface (stabilator) is of the all movable slab type with an anti-servo tab mounted on the trailing edge. This tab, actuated by a control mounted on the console between the front seats, also acts as a longitudinal trim tab (refer to Figure 7-13).

The vertical tail is fitted with a rudder which incorporates a combination rudder trim and anti-servo tab. The rudder trim control is located on the control console between the front seats.

FLAPS

The flaps are manually operated and spring loaded to return to the retracted (up) position. A four-position flap control handle (Figure 7-13) located on the console between the front seats adjusts the flaps for reduced landing speeds and glide path control.

**FLAP AND TRIM CONTROLS**

Figure 7-13

To extend the flaps, pull the handle up to the desired setting - 10, 25 or 40 degrees. To retract, depress the button on the end of the handle and lower the control.

An over-center lock incorporated in the actuating linkage holds the right flap when it is in the retracted (up) position so that it may be used as a step.

NOTE

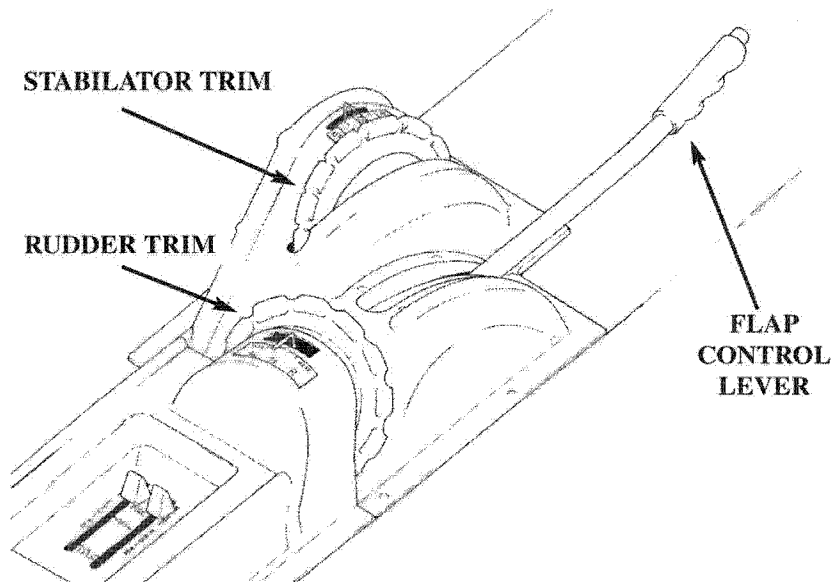
The right flap will support a load only in the fully retracted (up) position. When loading and unloading passengers, make sure the flaps are in the fully retracted (up) position.

7.15 FUEL SYSTEM

Fuel is stored in two 55 gallon fuel tanks, one in each nacelle (Figure 7-15). One gallon of fuel in each nacelle is unusable, giving a total of 108 usable gallons. The minimum fuel grade is 100 octane. The fuel tank vents, one installed under each wing, feature an anti-icing design to prevent ice formation from blocking the fuel tank vent lines.

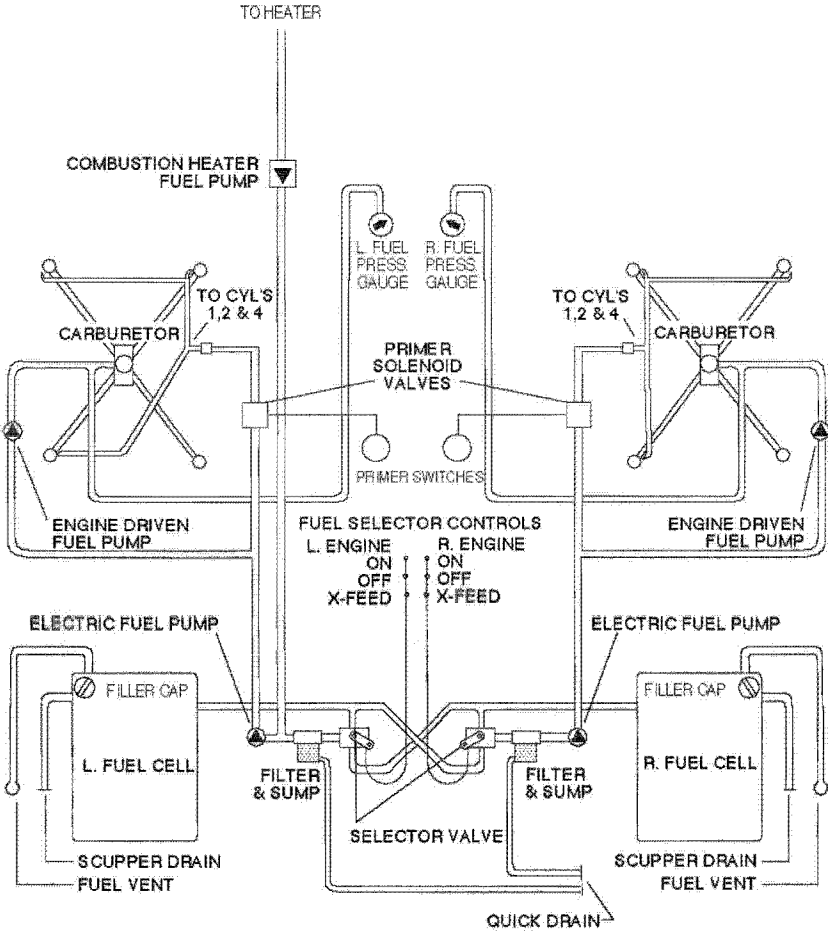

FUEL SYSTEM SCHEMATIC

Figure 7-15

FUEL PUMPS

Normally, fuel is supplied to the engines through engine-driven fuel pumps. Auxiliary electric fuel pumps serve as a back-up feature. The electric fuel pumps are controlled by rocker switches on the switch panel below and to the right of the pilot's control column. The electric fuel pumps should be ON during takeoffs and landings.

ELECTRIC PRIMER SYSTEM

The fuel primer system is used to provide fuel to the engine during start and makes use of electric pumps mounted in each wing and solenoid controlled primer valves. Left and Right primer switches are located on either side of the starter switch.

NOTE

The electric fuel pumps must be ON to operate the electric fuel primers.

With fuel pressure available, the primer button is depressed actuating the primer solenoid valve and allowing fuel to flow through the lines to the primer jets in the intake of the number 1, 2 and 4 cylinders.

FUEL GAUGES

Fuel quantities and pressures are indicated on gauges located to the left of the pilot's control column. There is a separate fuel quantity gauge for each tank.

A calibrated fuel dipstick is provided with the airplane. To visually check the quantity of fuel in a tank, insert the dipstick to the bottom of the tank, close off the protruding end with a finger, withdraw the dipstick, and read the fuel level. The most accurate reading will be obtained with the airplane on level ground.

FUEL DRAINS

Before each flight, fuel must be drained from the low points in the fuel system to ensure that any accumulation of moisture or sediment is removed from the system. A fuel drain is provided for each half of the fuel system. The fuel drains are located on the right side of the fuselage just forward of the entrance step. (Refer to fuel draining procedure in paragraph 8.21, Fuel System.)

FUEL CONTROLS

Fuel management controls are located on the console between the front seats (Figure 7-17). There is a control lever for each engine, and each is placarded ON - OFF - X-FEED. During normal operation, the levers are in the ON position, and each engine draws fuel from the tanks on the same side as the engine. When the X-FEED position is selected the engine will draw fuel from the tank on the opposite side in order to extend range and keep fuel weight balanced during single-engine operation. The OFF position shuts off the fuel flow to that engine.

NOTE

When one engine is inoperative and the fuel selector for the operating engine is on X-FEED the selector for the inoperative engine must be in the OFF position. Do not operate with both selectors on X-FEED. Do not take off or land with a selector on X-FEED.

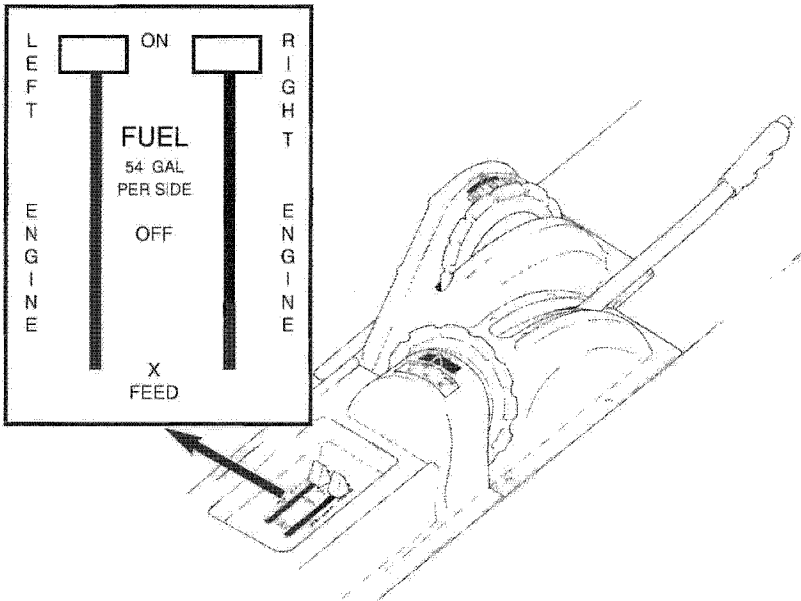

FUEL SYSTEM CONTROLS

Figure 7-17

7.17 ELECTRICAL SYSTEM

The electrical system is a negative-ground, dual-fed, split-bus system capable of supplying sufficient current for complete night IFR equipment.

ALTERNATORS

The primary electrical power is supplied by two belt-driven 14 volt, 70 ampere alternators (Figure 7-19), one mounted on each engine. The alternator provides full electrical power output even at low engine rpm. This provides improved radio and electrical equipment operation and increases battery life by reducing battery load.

VOLTAGE REGULATORS

Each alternator is protected by an alternator control unit which incorporates a voltage regulator and an overvoltage relay. The regulators maintain effective load sharing while regulating electrical system bus voltage to 14-volts. An overvoltage relay in each alternator circuit prevents damage to electrical and avionics equipment by taking an alternator off the line if its output exceeds 17-volts. If this should occur, the ALternator light on the annunciator panel will illuminate.

BATTERY

A 35 ampere-hour, 12-volt battery provides current for starting, for use of electrical equipment when the engines are not running, and for a source of stored electrical power to back up the alternator output. The battery, which is located in the nose section is normally kept charged by the alternators. If it becomes necessary to charge the battery, it should be removed from the airplane.

SWITCHES

The engine switches, including the Battery Master, left and right Alternators, left and right Magnetos, left and right Starters and left and right Fuel Pumps are located on the lower panel (Figure 7-19) in front of the pilot.

The light switches, the Radio Master switch, and the Day/Night Dimmer switch (if installed) are located to the left of the copilot control column.

The Pitot Heat switch and the environmental switches are located to the right of the copilot control column.

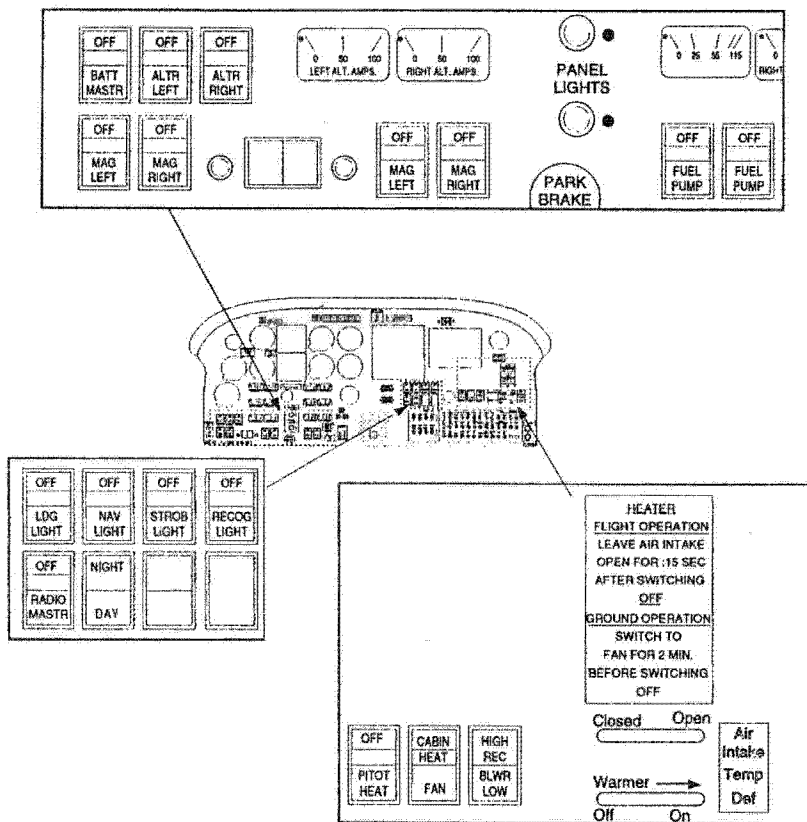

ELECTRICAL POWER SWITCHES

Figure 7-19

CIRCUIT BREAKERS

The electrical system and equipment are protected by circuit breakers located on a circuit breaker panel on the lower right side of the instrument panel (Figure 7-21). The circuit breaker panel is provided with blank spaces to accommodate additional circuit breakers if extra electrical equipment is installed. In the event of equipment malfunctions or a sudden surge of current, a circuit breaker can trip automatically. The pilot can reset the breaker by pressing it in (preferably after a few minutes cooling period). The circuit breakers can be pulled out manually.

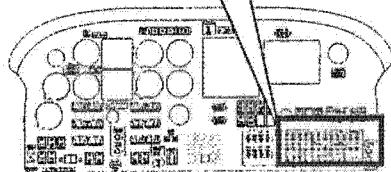
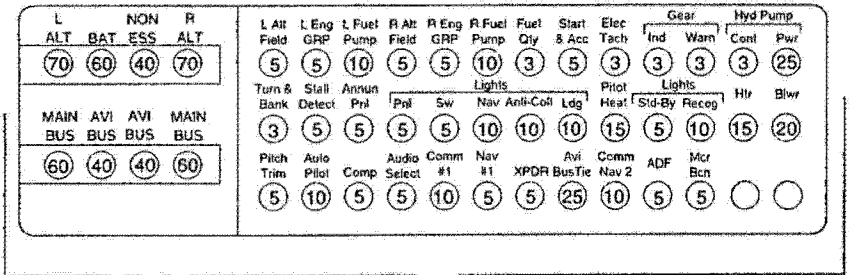

TYPICAL CIRCUIT BREAKER PANEL

Figure 7-21

POWER DISTRIBUTION

A battery bus (Figure 7-23), located in the battery compartment, provides a continuous source of power to the clock, the engine hourmeter, the flight-time hourmeter and the heater hourmeter. Because the battery bus is connected directly to the battery, power is available even when the Battery Master switch is OFF. Fuses located on the battery bus are used to protect these circuits.

When the Battery Master switch is turned ON, the battery solenoid contactor closes, enabling current to flow from the battery to both the starter contactors and the tie bus. Tie bus overcurrent protection is provided by a 60 amp tie bus BATTERY circuit breaker. The tie bus, located on the left of the circuit breaker panel (Figure 7-21), distributes power to other systems through circuit breakers.

Each alternator system has an independent ON-OFF rocker switch and a solid state voltage regulator that automatically regulates alternator field current. When selected ON, the positive output of each alternator is fed through individual shunts to the tie bus. Overcurrent protection is provided by the 70 amp tie bus L ALT and R ALT circuit breakers.

A main bus, a non-essential bus and two avionics buses, with associated circuit breakers, are located at the circuit breaker panel. The two avionics buses are interconnected through the avionics bus 25 amp AVI BUS TIE circuit breaker.

Current is fed from the tie bus to the main bus by two conductors. In line diodes prevent reverse current flow to the tie bus. Two tie bus 60 amp MAIN BUS circuit breakers protect the main bus from an overload.

Current from the tie bus is fed to each avionics bus through independent solenoid contactors. When the Radio Master switch is selected ON, both solenoid contactors close, permitting current flow to both avionics busses. Avionics bus overload protection is provided by the 40 amp AVI BUS #1 and AVI BUS # 2 circuit breakers. Should the need arise, either avionics bus can be isolated by pulling out the avionics bus AVI BUS TIE circuit breaker and the appropriate tie bus avionics circuit breaker.

The non-essential bus is also fed from the tie bus. Overload protection is provided by the tie bus 40 amp NON ESS circuit breaker.

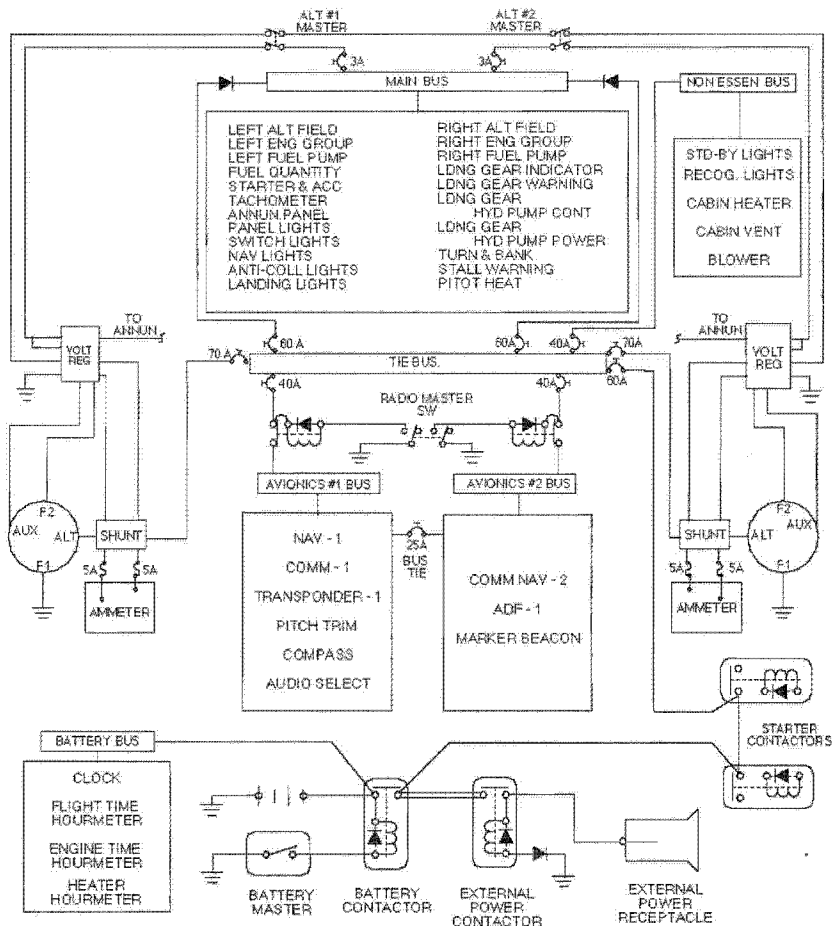

ELECTRICAL POWER DISTRIBUTION SYSTEM

Figure 7-23

SYSTEM MONITORS

Dual ammeters and two annunciator lights provide a means of monitoring electrical system operation. Two ammeters, located to the left of the pilot's control column, indicate the individual electrical load of each alternator. Should an overvoltage condition occur in either alternator, its voltage regulator will shut off the voltage of that alternator. Output from either alternator can be shut off manually by turning that alternator's switch OFF.

The two annunciator lights are located at the upper right of the pilot's panel. When either alternator fails, or is selected OFF, the amber ALT annunciator light will illuminate. A low voltage monitor, also connected to the tie bus, will illuminate the red LO BUS annunciator light when the system drops from bus voltage (14 Vdc) to battery voltage (approx. 12.5 Vdc). A fuse provides overload protection for the voltage monitor.

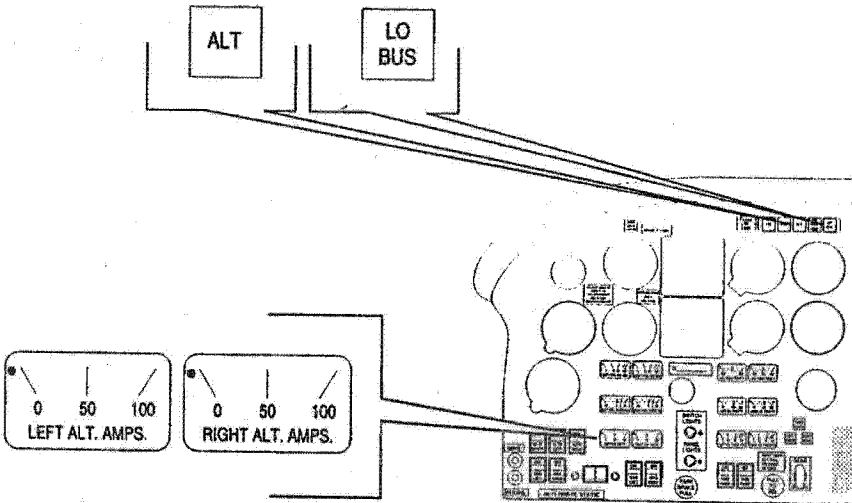

SYSTEM MONITORS

Figure 7-25

LIGHTS

Interior lighting consists of post lights and internally lighted avionics and switches. Radio, panel, and switch lights are controlled by rheostat switches located below the pilot's control column.

A floodlight, mounted in the overhead panel, provides additional instrument and cockpit lighting for night flying. The light is controlled by a rheostat switch located adjacent to the light. A map light window in the lens is actuated by an adjacent switch.

WARNING

The navigation lights (NAV LIGHT) switch must be OFF to obtain gear lights full intensity during daytime flying. When the aircraft is operated at night and the NAV LIGHT switch is turned ON, the gear lights will automatically dim.

WARNING

On aircraft equipped with a Day/Night Dimmer switch, the switch must be set to DAY to obtain gear lights full intensity during daytime flying. When the aircraft is operated at night and the Day/Night Dimmer switch is set to NIGHT, the gear lights will automatically dim.

Exterior lighting systems include landing/taxi lights, navigation lights, strobe/anti-collision lights, and recognition lights. The wing tip recognition light system consists of two lights; one in each wing tip.

WARNING

Anti-collision lights should not be operating when flying through cloud, fog or haze, since the reflected light can produce spatial disorientation. Strobe lights should not be used in close proximity to the ground, such as during taxiing, takeoff or landing.

EXTERNAL POWER RECEPTACLE

Should the airplane's battery be depleted, a receptacle located on the lower right side of the nose section permits using an external battery for engine start.

CAUTION

External power is supplied directly to the electrical bus. Turn off all electrical equipment before applying or removing external power.

EXTERNAL POWER RECEPTACLE (Continued)

Turn the Battery Master switch and all electrical equipment OFF. Connect the power connector plug assembly to an appropriate external battery. Insert the plug into the external power receptacle. This completes a circuit which permits current to flow from the external power source directly to the starter contactors and the tie bus. Instructions on a placard located on the cover of the receptacle should be followed when starting with external power. For instructions on the use of the external power, refer to Starting Engines - Section 4. For further information see EXTERNAL POWER RECEPTACLE in Section 8 of this Handbook.

7.19 VACUUM SYSTEM

The vacuum system operates the air-driven attitude gyro instrument. The vacuum system (Figure 7-27) consists of two engine-driven, dry-type vacuum pumps, two vacuum regulator valves containing filters, a manifold check valve and the necessary plumbing on each engine. A shear drive protects the engine from damage.

A vacuum gauge, incorporating two red flow buttons, mounted on the right side of the instrument panel (refer to Figure 7-27), provides information to the pilot regarding operation of the vacuum system. When both pumps are operating satisfactorily, neither flow button is visible. If vacuum is lost from either pump or from any other malfunction, the manifold check valve automatically closes and vacuum is supplied by one pump. The left flow button will protrude should the left pump fail, while the right flow button will protrude should the right pump fail.

Any decrease in pressure in a system that has remained constant over an extended period may indicate a dirty filter, dirty screens, possibly a sticking vacuum regulator or leak in system. The low vacuum switch, mounted upstream of the manifold check valve, illuminates the VAC annunciator light should the system vacuum fall below a specified pressure. Zero pressure would indicate sheared pump drives, defective pumps, possibly a defective gauge or collapsed line. In the event of any gauge variation from the norm, have a mechanic check the system to prevent possible damage to the system components or eventual failure of the system.

A vacuum regulator is provided in the system to protect the gyros. The valve is set so the normal vacuum reads 4.8 to 5.2 inches of mercury, a setting which provides sufficient vacuum to operate all the gyros at their rated RPM. Higher settings will damage the gyros and with a low setting the gyros will be unreliable. A regulator is located adjacent to each pump.

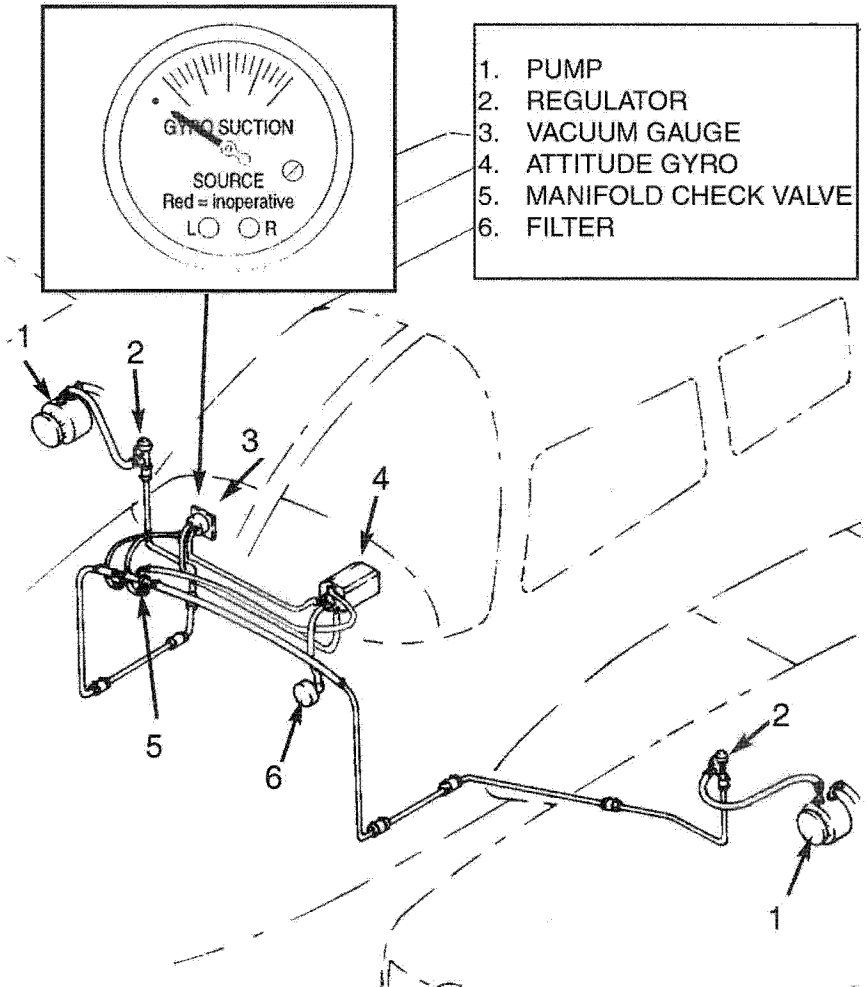

VACUUM SYSTEM

Figure 7-27

7.21 PITOT STATIC SYSTEM

The pitot static system (Figure 7-29) supplies both pitot and static pressure for the airspeed indicator and static pressure for the altimeter, vertical speed indicator, blind encoder and autopilot. Pitot and static pressure are picked up by the pitot head on the bottom of the left wing.

The control valve for an alternate static source is located below the left side of the instrument panel. When the valve is set in the alternate position, the altimeter, vertical speed indicator, blind encoder, autopilot and airspeed indicator will be using cabin air for static pressure. The storm window and cabin vents must be closed and the cabin heater and defroster must be on during alternate static source operation. The altimeter error is less than 50 feet unless otherwise placarded.

To prevent bugs and water from entering the pitot and static pressure holes when the airplane is parked, a cover should be placed over the pitot head. A partially or completely blocked pitot head will give erratic or zero readings on the instruments.

NOTE

During preflight, check to make sure the pitot cover is removed.

Pitot and static lines can be drained through separate drain valves located on the lower left sidewall adjacent to the pilot.

A heated pitot head installation alleviates problems with icing or heavy rain. The switch for pitot heat is located on the switch panel above the circuit breaker panel. The pitot heat system has a separate circuit breaker located in the circuit breaker panel and labeled PITOT HEAT. The operational status of the pitot heat system should be included in the preflight check.

CAUTION

Care should be exercised when checking the operation of the heated pitot head. The unit becomes very hot. Ground operation of pitot heat should be limited to 3 minutes maximum to avoid damaging the heating units.

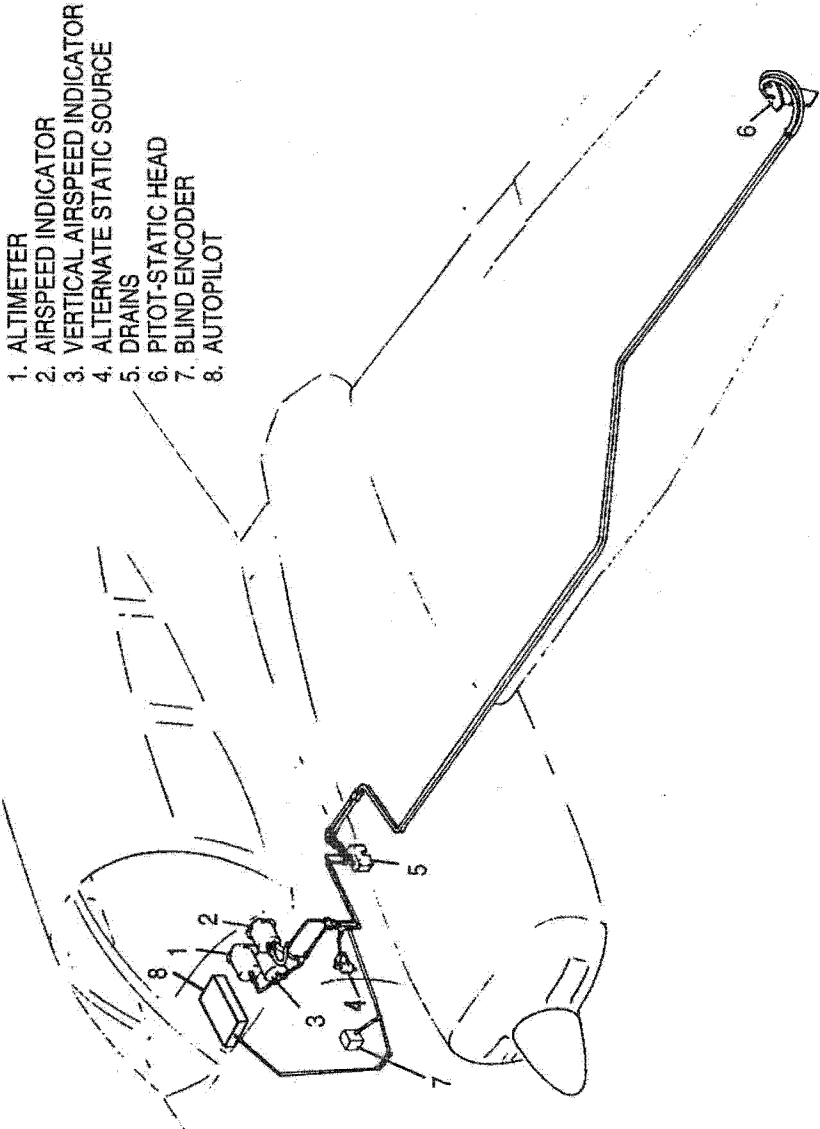

PITOT AND STATIC PRESSURE SYSTEM

Figure 7-29

7.23 HEATING, VENTILATING AND DEFROSTING SYSTEM

HEAT

Heated air for cabin heat and windshield defrosting is provided by a Janitrol combustion heater located in the forward fuselage (Figure 7-31). Air from the heater is distributed by a manifold down through ducts along the cabin floor to outlets at each seat. Heated air from the manifold is also moved up through two ducts to the defroster outlets.

Operation of the combustion heater is controlled by a three-position switch located on the instrument panel (Figure 7-33) and labeled **CABIN HEAT - FAN**. Airflow and temperature are regulated by the three levers to the right of the switch. The upper lever regulates **AIR INTAKE** and the center lever regulates cabin **TEMPERATURE**. Cabin comfort can be maintained as desired through various combinations of lever positions. Passengers have secondary control over heat output by individually adjustable outlets at each seat location. The third lever on the instrument panel controls heated airflow to the windshield **DEFROSTERS**.

For cabin heat, the **AIR INTAKE** lever on the instrument panel must be partially or fully open and the three-position switch set to the **CABIN HEAT** position. This simultaneously starts fuel flow and ignites the heater. During ground operation, it also activates the ventilation blower which is an integral part of the combustion heater. With instant starting and no need for priming, heat should be felt within a few seconds. When cabin air reaches the temperature selected on the cabin **TEMPERATURE** lever, ignition of the heater cycles automatically to maintain the selected temperature.

The combustion heater uses fuel from the airplane fuel system. An electric fuel pump draws fuel from the left tank at a rate of approximately one-half gallon per hour. Fuel used for heater operation should be considered when planning for a flight.

Hours of combustion heater operation can be monitored from an instrument panel mounted hourmeter (Figure 7-33). The meter is located above and to the right of the control quadrant.

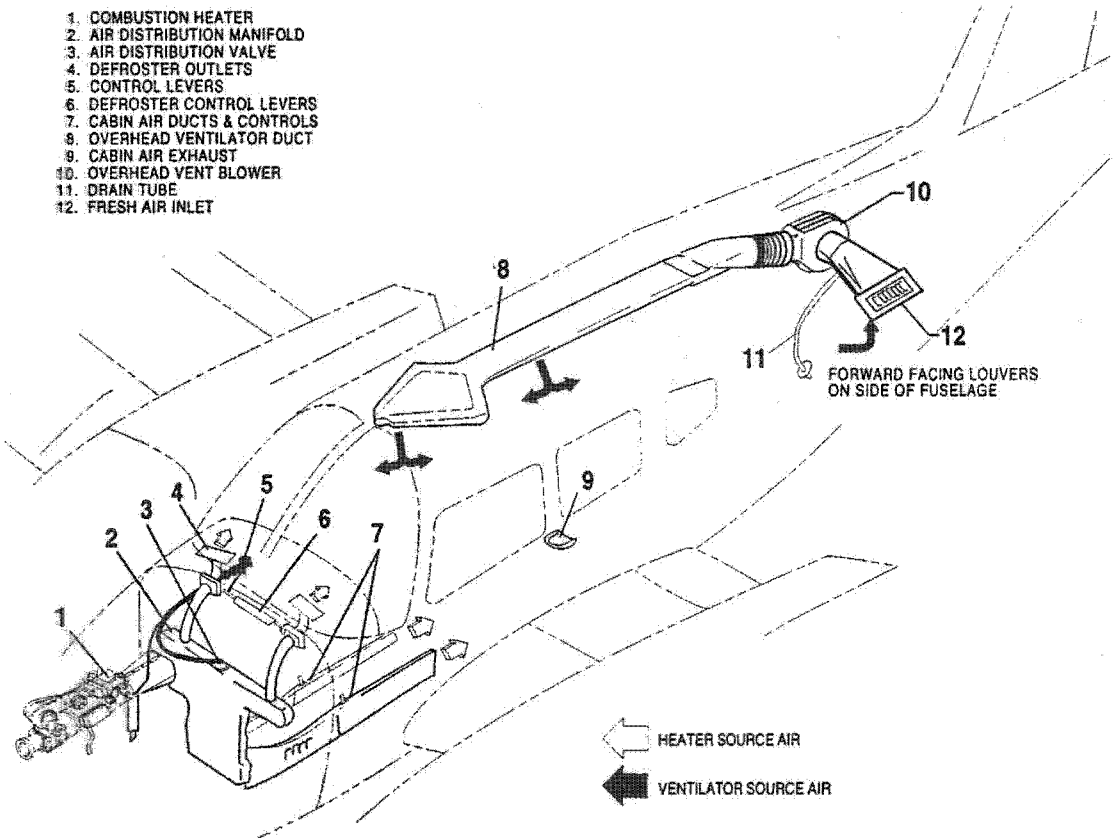

1. COMBUSTION HEATER
2. AIR DISTRIBUTION MANIFOLD
3. AIR DISTRIBUTION VALVE
4. DEFROSTER OUTLETS
5. CONTROL LEVERS
6. DEFROSTER CONTROL LEVERS
7. CABIN AIR DUCTS & CONTROLS
8. OVERHEAD VENTILATOR DUCT
9. CABIN AIR EXHAUST
10. OVERHEAD VENT BLOWER
11. DRAIN TUBE
12. FRESH AIR INLET

FORWARD FACING LOUVERS
ON SIDE OF FUSELAGE

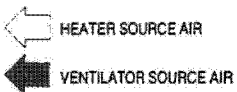

ENVIRONMENTAL SYSTEM

Figure 7-31

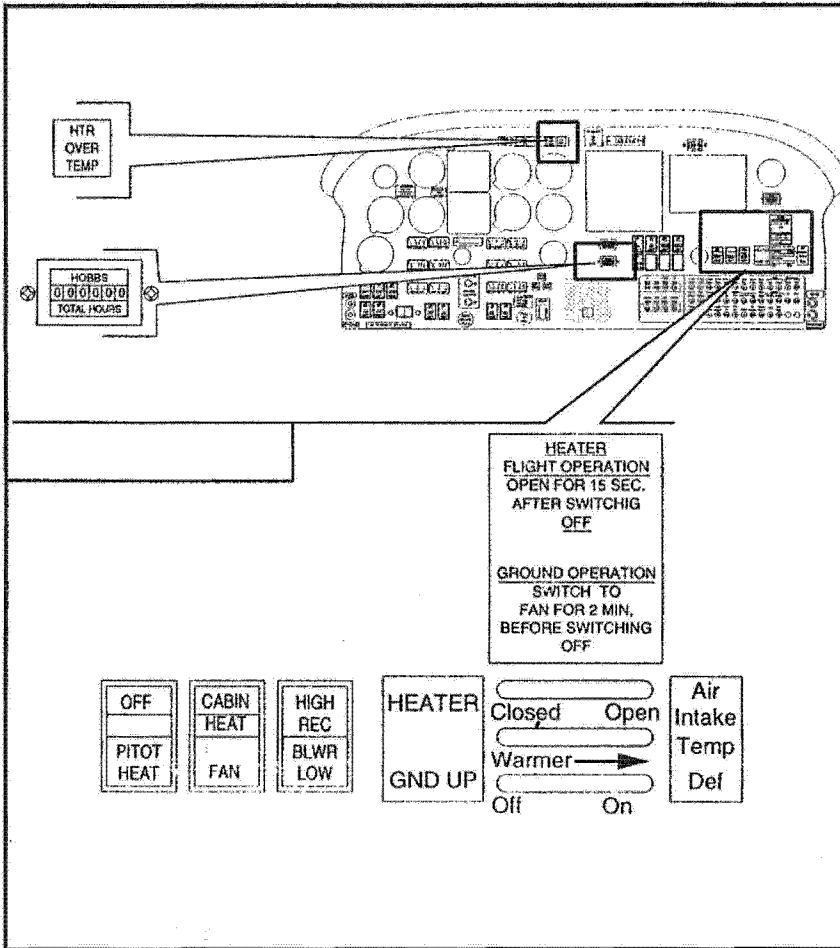

ENVIRONMENTAL CONTROLS AND ANNUNCIATORS

Figure 7-33

Safety Switches

Two safety switches activated by the intake valve and located aft of the heater unit prevent both fan and heater operation when the air intake lever is in the closed position. A micro switch, which actuates when the landing gear is retracted, turns off the ventilation blower so that in flight the cabin air is circulated by ram air pressure only.

Overheat Switch and Annunciator

An overheat switch located in the heater unit acts as a safety device to render the heater inoperative if a malfunction should occur. Should the switch deactivate the heater, the red HEATER OVER TEMP annunciator light on the instrument panel (Figure 7-33) will illuminate. The overheat switch is located on the aft inboard end of the heater vent jacket. A red reset button is located on the heater shroud in the nose cone compartment.

To prevent activation of the overheat switch upon normal heater shutdown during ground operation, turn the three-position switch to FAN for two minutes with the air intake lever in the open position before turning the switch to OFF. During flight, leave the air intake lever open for a minimum of fifteen seconds after turning the switch to OFF.

VENTILATION

When heat is not desired during ground operation, place the three-position switch in the FAN position and the ventilation fan will blow fresh air through the heater duct work for cabin ventilation and windshield defogging. To introduce fresh, unheated air into the cabin during flight, the air intake should be open and the heater off. Ram air enters the system and can be individually regulated at each floor outlet.

Overhead outlets also supply fresh air for cabin ventilation. The occupant of each seat can manually adjust an outlet in the ceiling to regulate the flow of fresh air to that seat area. A fresh air blower is installed in the overhead ventilation system to provide additional fresh air flow during ground operation. Operation of the fresh air blower is controlled by a three-position switch located on the instrument panel (Figure 7-33) and labeled HIGH-REC BLWR-LOW.

7.25 INSTRUMENT PANEL

The instrument panel (Figure 7-35) is designed to accommodate the customary advanced flight instruments and the normally required power plant instruments. The artificial horizon is vacuum operated and located in the center of the left instrument panel, above the pilot's control column. The vacuum gauge is located on the right side of the instrument panel. The Horizontal Situation Indicator (HSI), located below the artificial horizon, and the turn coordinator, located to the left of the HSI, are electrically operated.

Various warning lights are located above the pilot's flight instruments on the left upper instrument panel. An annunciator panel incorporating a press-to-test feature, is mounted in the upper instrument panel to warn the pilot of a possible malfunction. Monitored functions include: OIL pressure, VACuum, ALternator, HTR (Heater) OVER TEMP, and LO BUS. To the left of the annunciator panel is the landing gear WARN GEAR UNSAFE light.

Closely monitor instrument panel gauges to check the condition of a system whose corresponding light on the annunciator panel illuminates. During preflight, the operational status of the annunciator panel should be tested by use of the Press-to-Test button. When the button is depressed, all annunciator panel lights should illuminate.

NOTE

When an engine is feathered, the ALternator, gyro VACuum air and engine OIL pressure annunciator lights will remain illuminated.

The column of gauges on the right side of the pilot's panel are engine related instruments. From top to bottom they are manifold pressure, tachometer (rpm), and exhaust gas temperature (EGT). Additional engine monitoring gauges are in two columns on either side of the pilot control column. The left column includes fuel quantity, fuel pressure and alternator amps. The right column includes cylinder head temperature, oil temperature and oil pressure. The normal operating range for ground and flight operation is indicated on the instruments by a green arc. Yellow arcs indicate a caution range while red lines dictate minimum or maximum limits.

7.25 INSTRUMENT PANEL (Continued)

Instrument panel lighting is provided by post lights and internally lighted avionics and switches. Lighting can be adjusted by two rheostat switches, labeled SWITCH LIGHTS and PANEL LIGHTS, located below the pilot's control column. Additional cockpit flood lighting is located in the overhead panel and controlled by an adjacent switch.

WARNING

The navigation lights (NAV LIGHT) switch must be OFF to obtain gear lights full intensity during daytime flying. When the aircraft is operated at night and the NAV LIGHT switch is turned ON, the gear lights will automatically dim.

WARNING

On aircraft equipped with a Day/Night Dimmer switch, the switch must be set to DAY to obtain gear lights full intensity during daytime flying. When the aircraft is operated at night and the Day/Night Dimmer switch is set to NIGHT, the gear lights will automatically dim.

The parking brake handle (PARK BRAKE - PULL) is located below the light rheostats. Just to the left of the control quadrant are the landing gear controls and indicators. The control quadrant - throttles and propeller and mixture controls - is in the center of the lower instrument panel. To the right of the control quadrant is the control friction lock.

Radios are mounted above and to the right of the control quadrant. A radio master (RADIO MASTR) switch is located to the right of the control quadrant. It controls the power to all radios through the radio master contactor. When the battery master (BATT MASTR) switch is turned ON, power is supplied to the radio master switch relay, opening the contactors and preventing current flow to the radios. When the radio master (RADIO MASTR) switch is turned ON, power is removed from the radio master switch relay, allowing the contactors to spring closed and permitting current flow to the radios.

7.25 INSTRUMENT PANEL (Continued)

If installed, a ground clearance energy saver system provides direct power to comm #1 with the battery master switch in the off position. An internally lit switch, located below the avionics stack provides annunciation for engagement of the system. When the switch is engaged, direct aircraft battery power is applied to comm #1, audio amplifier and radio accessories. Ground clearance must be turned off or depletion of battery could result. To turn off the ground clearance, turn the battery master switch on momentarily, then off.

NOTE

The battery master switch must be in the off position for ground clearance system to operate.

Exterior lighting switches are grouped together above and to the right of the control quadrant. They include the landing/taxi light, nav. lights, strobe lights, and the wingtip recognition lights.

Switches and knobs for controlling cabin comfort and windshield defogging are located to the right of the copilot's control column. The Pitot Heat switch is also located with this group. Directly below is the circuit breaker panel containing breakers of the TIE BUS, the MAIN BUS, the NON - ESSENTIAL BUS and two avionics busses (AVI BUS).

THIS PAGE INTENTIONALLY LEFT BLANK

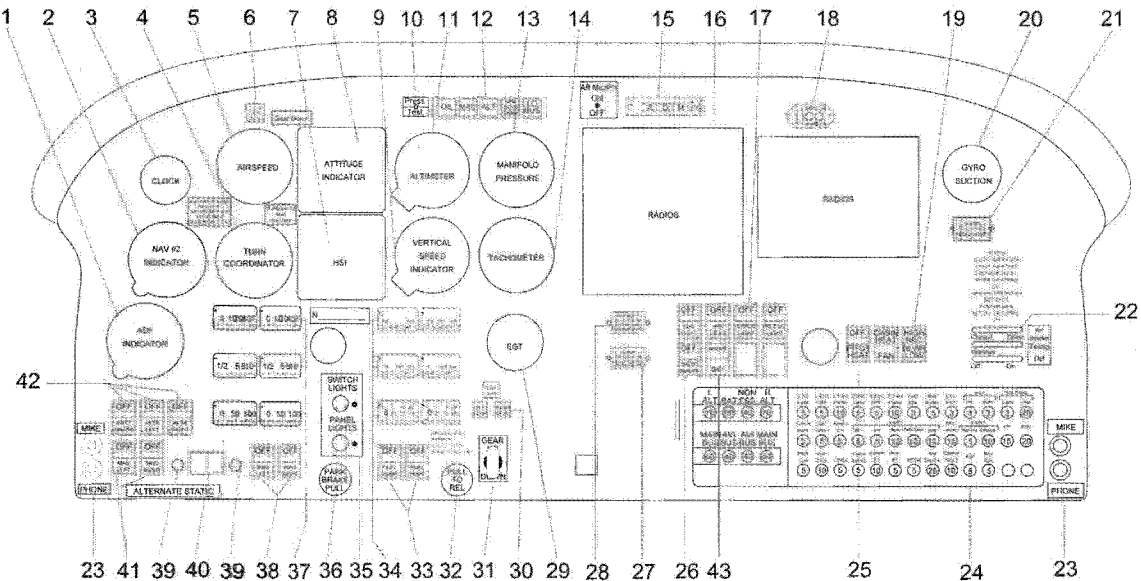

INSTRUMENT PANEL

Figure 7-35

1. ADF INDICATOR
2. NAV #2 INDICATOR
3. CLOCK
4. TURN COORDINATOR
5. AIRSPEED INDICATOR
6. GEAR UNSAFE WARNING LIGHT
7. HORIZONTAL SITUATION INDICATOR
8. ATTITUDE INDICATOR
9. VERTICAL SPEED INDICATOR
10. ANNUNCIATOR TEST SWITCH
11. ALTIMETER
12. ANNUNCIATOR DISPLAY
13. DUAL MANIFOLD PRESSURE
14. DUAL TACHOMETER
15. MARKER BEACON
16. AVIONICS
17. EXTERIOR LIGHT SWITCHES
18. GYRO SLAVING CONTROL
19. ENVIRONMENTAL CONTROL SWITCHES
20. GYRO SUCTION
21. ENGINE HOURMETER
22. CABIN TEMP CONTROLS
23. MIC/PHONE JACKS
24. CIRCUIT BREAKER PANEL
25. PITOT HEAT SWITCH
26. RADIO MASTER SWITCH
27. HEATER HOURMETER
28. FLIGHT HOURMETER
29. EXHAUST GAS TEMPERATURE
30. GEAR POSITION INDICATOR
31. LANDING GEAR SELECTOR
32. EMERGENCY GEAR EXTENSION HANDLE
33. FUEL PUMP SWITCHES
34. INSTRUMENT CLUSTER
 - L & R CYL HEAD TEMPERATURE
 - L & R OIL TEMPERATURE
 - L & R OIL PRESSURE
35. INTERIOR LIGHTS
36. PARKING BRAKE HANDLE
37. INSTRUMENT CLUSTER
 - L & R FUEL QUANTITY
 - L & R FUEL PRESSURE
 - L & R ALTERNATOR AMMETERS
38. RIGHT ENGINE MAGNETO SWITCHES
39. PRIMER SWITCHES
40. L & R START SWITCHES
41. LEFT ENGINE MAGNETO SWITCHES
42. BATTERY & ALTERNATOR SWITCHES
43. DAY/NIGHT DIMMER SWITCH

INSTRUMENT PANEL (Continued)

Figure 7-35 (Continued)

7.27 CABIN FEATURES

Cabin entry is made through the cabin door on the right side. The cabin door is double latched. To close the cabin door, hold the door closed with the armrest while moving the side door latch (Figure 7-37) down to the LATCHED position. Then engage the top latch to the LATCHED position. Both latches must be secure before flight.

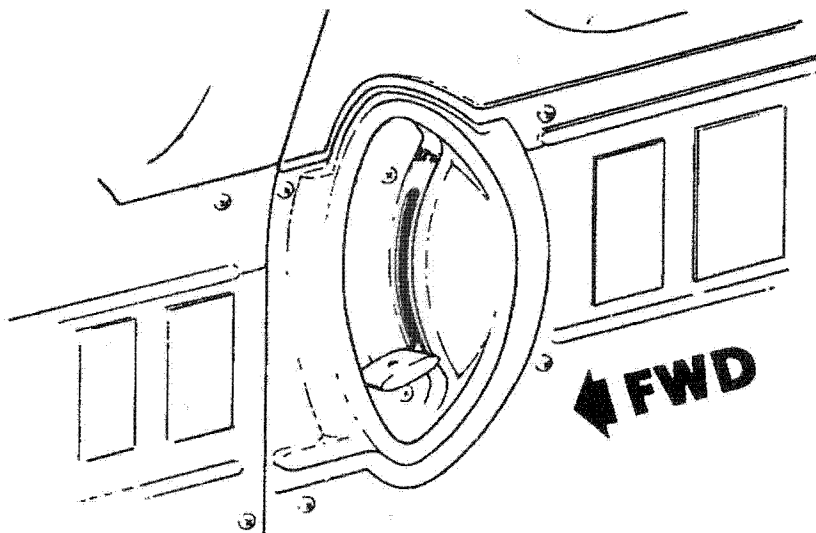

CABIN DOOR SIDE LATCH

Figure 7-37

The pilot's left side window is an emergency exit. The emergency exit release handle is located beneath the thermoplastic cover on the vertical post between the first and second left side windows (Figure 7-39).

CAUTION

The emergency exit is for ground use only. When released, the window will fall free from the fuselage.

**EMERGENCY EXIT**

Figure 7-39

STANDARD FEATURES

Standard front cabin features include cabin and baggage door locks, a pilot's storm window, map pockets, ashtrays, and sun visors. The left sun visor contains Takeoff/ Landing Checklist and the right sun visor includes the Power Setting Table. An armrest is located on the side panel adjacent to each front seat. Additional standard cabin items are pockets on the front seat backs, a portable fire extinguisher, a special cabin sound-proofing package, a coat hanger support bar and baggage restraint straps in the aft baggage area.

A worktable is available and can be attached to the rear of either the pilot or copilot seat. The worktable is stored along the left side in the baggage area. It is secured with a strap.

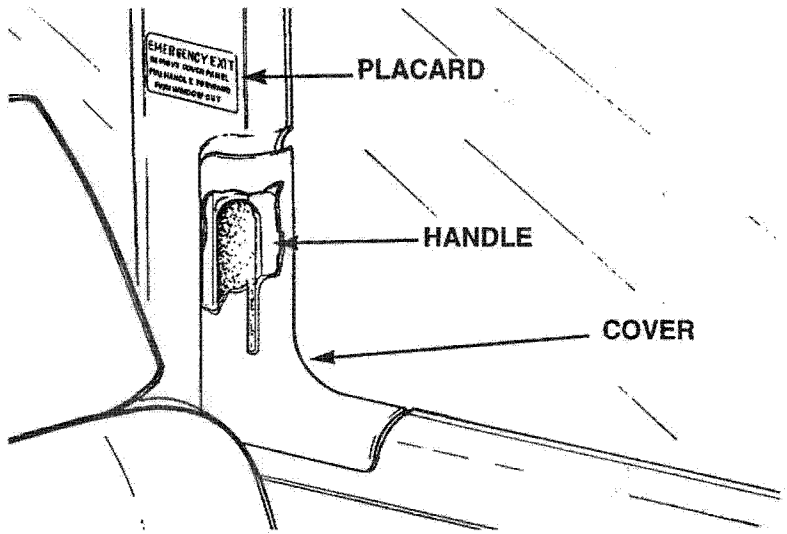
SEATS

All seat backs have three positions: normal, intermediate and recline. An adjustment lever is located at the base of each seat back on the outboard side.

The two front seats are adjustable fore, aft and vertically. The seats are adjustable fore and aft by lifting the bar below the seat front and moving to the desired position. Release the handle and move the seat until the locking pin engages. To raise the vertically adjustable pilot and copilot seats, push back on the pushbutton located at the lower right of each seat, relieve the weight from the seat and it will rise. To lower the seat, push the button and apply weight until the proper position is reached.

The rear seats are easily removed to provide room for bulky items. Rear seat installations incorporate leg retainers with latching mechanisms, which must be released before the rear seats can be removed. Releasing the retainers is accomplished by depressing the plunger behind each rear leg.

NOTE

To remove the rear seats, depress the plunger behind each front leg and slide seat to rear.

SEAT BELTS AND SHOULDER HARNESSSES

Seat belts and adjustable shoulder harnesses with inertial reels are standard on all four seats. The pilot should adjust this fixed seat belt strap so that all controls are accessible while maintaining adequate restraint for the occupant. The seat belt should be snugly fastened over each unoccupied seat.

The shoulder harness is routed over the shoulder adjacent to the window and attached to the seat belt in the general area of the occupant's inboard hip. A check of the inertial reel mechanism is made by pulling sharply on the strap. The reel should lock in place and prevent the strap from extending. For normal body movements, the strap will extend or retract as required. Shoulder harnesses should be routinely worn during takeoff, landing and whenever an in-flight emergency situation occurs.

FIRE EXTINGUISHER

A portable, handheld, fire extinguisher, containing Halon 1211, is mounted between the pilot and copilot seats, behind the fuel selector console. Read the instructions on the nameplate and become familiar with the unit before an emergency situation. It has a discharge rate of no less than 8 seconds and no more than 10 seconds. The original weight of the extinguisher is 4 pounds 14 ounces \pm 2 ounces.

To operate, remove it from the quick-release bracket, hold it upright with the spray nozzle pointing forward. Slide the red safety catch down with the thumb, direct the nozzle towards the base of the fire source and squeeze the lever with the palm of the hand. Squeezing ejects an indicator disc from the rear of the operating head of the extinguisher, and extinguishant is released from the nozzle in a wide, flat pattern.

Maximum extinguishing effect is obtained by moving in towards base of the fire source as it is extinguished. Releasing the lever automatically stops further discharge, retaining part of the charge for further use. Ejection of the disc provides visual indication of partial or total discharge.

7.29 BAGGAGE AREA

The 24 cubic foot baggage compartment, located aft of the seats, has a weight capacity of 200 pounds. This compartment is loaded and unloaded through a separate 22 x 20 inch baggage door, and the compartment is accessible during flight. Tie-down straps are provided and they should be used at all times. The baggage compartment door and passenger door use the same key.

NOTE

It is the pilot's responsibility to be sure when baggage is loaded that the airplane C.G. falls within the allowable C.G. range. (See Weight and Balance Section.)

7.31 FINISH

The standard exterior finish is painted with acrylic enamel. To keep the finish attractive, economy size spray cans of touch-up paint are available from Piper Dealers.

7.33 STALL WARNING

An approaching stall is indicated by a stall warning horn which is activated between five and ten knots above stall speed. Mild airframe buffeting and gentle pitching may also precede the stall. Stall speeds are shown on the Stall Speed vs Angle of Bank graph in Section 5.

The stall warning indication consists of a continuous sounding horn located behind the instrument panel. The stall warning horn has a different sound from that of the gear warning horn which has a 90 cycles per minute beeping sound.

The stall warning horn is activated by two lift detectors on the leading edge of the left wing, outboard of the engine nacelle. The inboard detector activates the horn when the flaps are in the 25 and 40 degree positions, the outboard when the flaps are in positions less than 10°. A squat switch in the stall warning system does not allow the units to be activated on the ground.

7.35 EMERGENCY LOCATOR TRANSMITTER

The Emergency Locator Transmitter (ELT) meets the requirements of FAR 91.52. It operates on self-contained batteries and is located in the aft fuselage section. It is accessible through a rectangular cover on the right hand side. A number 2 Phillips screwdriver is required to remove the cover.

A battery replacement date is marked on the transmitter. To comply with FAA regulations, the battery must be replaced on or before this date. The battery must also be replaced if the transmitter has been used in an emergency situation or if the accumulated test time exceeds one hour, or if the unit has been inadvertently activated for an undetermined time period.

NOTE

If for any reason a test transmission is necessary, the test transmission should be conducted only in the first five minutes of any hour and limited to three audio sweeps. If tests must be made at any other time, the tests should be coordinated with the nearest FAA tower or flight service station.

NARCO ELT 10 OPERATION

Located on the ELT unit itself is a three position switch placarded ON, OFF and ARM. The ARM position sets the ELT so that it will transmit after impact and will continue to transmit until its battery is drained. The ARM position is selected when the ELT is installed in the airplane and it should remain in that position.

To use the ELT as a portable unit in an emergency, remove the cover and unlatch the unit from its mounting base. The antenna cable is disconnected by a left quarter-turn of the knurled nut and a pull. A sharp tug on the two small wires will break them loose. Deploy the self-contained antenna by pulling the plastic tab marked **PULL FULLY TO EXTEND ANTENNA**. Move the switch to ON to activate the transmitter.

7.35 EMERGENCY LOCATOR TRANSMITTER (Continued)

In the event the transmitter is activated by an impact, it can only be turned off by moving the switch on the ELT unit to OFF. Normal operation can then be restored by pressing the small clear plastic reset button located on the top of the front face of the ELT and then moving the switch to ARM.

Pilot Remote Switch

A pilot's remote switch located on the left side panel is provided to allow the transmitter to be turned on from inside the cabin. The pilot's remote switch is placarded ON and ARMED. The switch is normally in the ARMED position. Moving the switch to ON will activate the transmitter. Moving the switch back to the ARMED position will turn off the transmitter only if the impact switch has not been activated.

Ground Check

The ELT should be checked to make certain the unit has not been activated during the ground check. Check by selecting 121.50 MHz on an operating receiver. If there is an oscillating chirping sound, the ELT may have been activated and should be turned off immediately. This requires removal of the access cover and moving the switch to OFF, then press the reset button and return the switch to ARM. Recheck with the receiver to ascertain the transmitter is silent.

NARCO ELT 910 OPERATION

On the ELT unit itself is a three position switch placarded ON, OFF and ARM. The ARM position sets the ELT so that it will transmit after impact and will continue to transmit until its battery is drained. The ARM position is selected when the ELT is installed in the airplane and it should remain in that position.

A pilot's remote switch, placarded ON and ARM, is located on the left side panel to allow the transmitter to be armed or turned on from inside the cabin. The switch is normally in the ARM position. Moving the switch to ON will activate the transmitter. A warning light, located above the remote switch, will blink continuously whenever the ELT is activated.

7.35 EMERGENCY LOCATOR TRANSMITTER (Continued)**NOTE**

The warning light will not blink if the ELT is activated by an incident that also results in severance of the airplane's power supply lines.

Should the ELT be activated inadvertently it can be reset by either positioning the remote switch to the ON position for two seconds, and then relocating it to the ARM position, or by setting the switch on the ELT to OFF and then back to ARM.

In the event the transmitter is activated by an impact, it can be turned off by moving the ELT switch OFF. Normal operation can then be restored by resetting the switch to ARM. It may also be turned off and reset by positioning the remote switch to the ON position for two seconds, and then to the ARM position.

The transmitter can be activated manually at any time by placing either the remote switch or the ELT switch to the ON position.

Ground Check

The ELT should be checked during postflight to make certain the unit has not been activated. Check by selecting 121.50 MHz on an operating receiver. If a downward sweeping audio tone is heard, the ELT may have been activated. Set the remote switch to ON. If there is no change in the volume of the signal, your airplane's ELT is probably transmitting. Setting the remote switch back to ARM will automatically reset the ELT and should stop the signal being received on 121.50 MHz.

ARTEX 110-4 ELT OPERATION

On the ELT unit itself is a two position switch placarded ON and OFF. The OFF position is selected when the transmitter is installed at the factory and the switch should remain in that position whenever the unit is installed in the airplane.

A pilots remote switch, placarded ON and ARM is located on the copilots instrument panel to allow the transmitter to be armed or turned on from inside the cabin. The switch is normally in ARM position. Moving the switch to ON will activate the transmitter. A warning light located above the remote switch will alert you when ever the ELT is activated.

7.35 EMERGENCY LOCATOR TRANSMITTER (Continued)**ARTEX 110-4 ELT OPERATION**

Should the ELT be activated inadvertently it can be reset by either positioning the remote switch to the ON then immediately relocating it to the ARM position, or by setting the switch on the ELT to ON and then back to OFF.

In the event the transmitter is activated by an impact, it can be turned off by moving the ELT switch OFF. Normal operation can then be restored by resetting the switch to ARM. It may also be turned off and reset by positioning the remote switch to the ON and then immediately to the ARM position.

The transmitter can be activated manually at any time by placing either the remote switch or the ELT switch to the ON position.

NOTE:

Three sweeps of the emergency tone and an illuminated warning light indicates a normally functioning unit. The warning light must illuminate during the first 3 second test period. If it does not illuminate, a problem is indicated such as a "G" switch failure.

The ELT should be checked during postflight to make certain the unit has not been activated. Check by selecting 121.50 MHz on an operating receiver. If a downward sweeping audio tone is heard the ELT may have been activated. Set the remote switch to ON. If there is no change in the volume of the signal, your airplane's ELT is probably transmitting. Setting the remote switch back to OFF will automatically reset the ELT and should stop the signal being received on 121.50 MHz.

TABLE OF CONTENTS

SECTION 8

AIRPLANE HANDLING, SERVICING AND MAINTENANCE

Paragraph No.		Page No.
8.1	General	8-1
8.3	Airplane Inspection Periods	8-2
8.5	Preventive Maintenance	8-3
8.7	Airplane Alterations	8-4
8.9	Ground Handling.....	8-5
8.11	Engine Induction Air Filter	8-7
8.13	Brake Service	8-8
8.15	Landing Gear Service.....	8-8
8.17	Hydraulic System Service	8-10
8.19	Propeller Service	8-10
8.21	Oil Requirements	8-11
8.23	Fuel System.....	8-12
8.25	Tire Inflation	8-15
8.27	Battery Service	8-15
8.29	Serial Number Plates.....	8-16
8.31	Lubrication	8-16

TABLE OF CONTENTS

SECTION 8

AIRPLANE HANDLING, SERVICING AND MAINTENANCE

Paragraph No.		Page No.
8.33	Cleaning	8-16
8.35	Winterization	8-19

SECTION 8

AIRPLANE HANDLING, SERVICING AND MAINTENANCE

8.1 GENERAL

This section provides guidelines relating to the handling, servicing and maintenance of the Seminole. For complete maintenance instructions, refer to the PA-44-180 Maintenance Manual.

WARNING

Inspection, maintenance and parts requirements for all non-PIPER approved STC installations are not included in this handbook. When a non-PIPER approved STC installation is incorporated on the airplane, those portions of the airplane affected by the installation must be inspected in accordance with the inspection program published by the owner of the STC. Since non-PIPER approved STC installations may change systems interface, operating characteristics and component loads or stresses on adjacent structures, PIPER provided inspection criteria may not be valid for airplanes with non-PIPER approved STC installations.

WARNING

Modifications must be approved in writing by PIPER prior to installation. Any and all other installations, whatsoever, of any kind will void this warranty in it's entirety.

8.1 GENERAL (CONTINUED)

WARNING

Use only genuine PIPER parts or PIPER approved parts obtained from PIPER approved sources, in connection with the maintenance and repair of PIPER airplanes.

Genuine PIPER parts are produced and inspected under rigorous procedures to insure airworthiness and suitability for use in PIPER airplane applications. Parts purchased from sources other than PIPER, even though identical in appearance, may not have had the required tests and inspections performed, may be different in fabrication techniques and materials, and may be dangerous when installed in an airplane.

Additionally, reworked or salvaged parts or those parts obtained from non-PIPER approved sources, may have service histories which are unknown or cannot be authenticated, may have been subjected to unacceptable stresses or temperatures or may have other hidden damage not discernible through routine visual or nondestructive testing. This may render the part, component or structural assembly, even though originally manufactured by PIPER, unsuitable and unsafe for airplane use.

PIPER expressly disclaims any responsibility for malfunctions, failures, damage or injury caused by use of non-PIPER approved parts.

8.1 GENERAL (CONTINUED)

Every owner should stay in close contact with an authorized Piper Service Center or Piper's Customer Service Department to obtain the latest information pertaining to their airplane, and to avail themselves of Piper's support systems.

Piper takes a continuing interest in having owners get the most efficient use from their airplane and keeping it in the best mechanical condition. Consequently, Piper, from time to time, issues service releases including Service Bulletins, Service Letters, Service Spares Letters, and others relating to the airplane.

Piper Service Bulletins are of special importance and Piper considers compliance mandatory. These are sent directly to the latest FAA-registered owners in the United States (U.S.) and Piper Service Centers worldwide. Depending on the nature of the release, material and labor allowances may apply. This information is provided to all authorized Piper Service Centers.

Piper Service Letters deal with product improvements and servicing techniques pertaining to the airplane. They are sent to Piper Service Centers and, if necessary, to the latest FAA-registered owners in the U.S. Owners should give careful attention to Service Letter information.

Piper Service Spares Letters offer improved parts, kits and optional equipment which were not available originally, and which may be of interest to the owner.

Piper offers a subscription service for Service Bulletins, Service Letters, and Service Spares Letters. This service is available to interested persons such as owners, pilots, and mechanics at a nominal fee, and may be obtained through an authorized Piper Service Center or Piper's Customer Service Department.

Maintenance manuals, parts catalogs, and revisions to both, are available from Piper Service Centers or Piper's Customer Service Department.

Any correspondence regarding the airplane should include the airplane model and serial number to ensure proper response.

8.3 AIRPLANE INSPECTION PERIODS

WARNING

All inspection intervals, replacement time limits, overhaul time limits, the method of inspection, life limits, cycle limits, etc., recommended by PIPER are solely based on the use of new, remanufactured or overhauled PIPER approved parts. If parts are designed, manufactured, remanufactured, overhauled and/or approved by entities other than PIPER, then the data in PIPER'S maintenance/service manuals and parts catalogs are no longer applicable and the purchaser is warned not to rely on such data for non-PIPER parts. All inspection intervals, replacement time limits, overhaul time limits, the method of inspection, life limits, cycle limits, etc., for such non-PIPER parts must be obtained from the manufacturer and/or seller of such non-PIPER parts.

Piper has developed inspection items and required inspection intervals (i.e.: 50, 100, 500, and 1000 hours) for the specific model aircraft. Appropriate forms are contained in the applicable Piper Service/Maintenance Manual, and should be complied with by a properly trained, knowledgeable, and qualified mechanic at a Piper Authorized Service Center or a reputable repair shop. Piper cannot accept responsibility for the continued airworthiness of any aircraft not maintained to these standards, and/or not brought into compliance with applicable Service Bulletins issued by Piper, instructions issued by the engine, propeller, or accessory manufacturers, or Airworthiness Directives issued by the FAA.

A programmed Inspection, approved by the Federal Aviation Administration (FAA), is also available to the owner. This involves routine and detailed inspections to allow maximum utilization of the airplane. Maintenance inspection costs are reduced, and the maximum standard of continuous airworthiness is maintained. Complete details are available from all local distributors representing The New Piper Aircraft, Inc.

In addition, but in conjunction with the above, the FAA requires periodic inspections on all aircraft to keep the Airworthiness Certificate in effect. The owner is responsible for assuring compliance with these inspection requirements and for maintaining proper documentation in logbooks and/or maintenance records.

8.3 AIRPLANE INSPECTION PERIODS (Continued)

A spectographic analysis of the engine oil is available from several sources. This inspection, if performed properly, provides a good check of the internal condition of the engine. To be accurate, induction air filters must be cleaned or changed regularly, and oil samples must be taken and sent in at regular intervals.

8.5 PREVENTIVE MAINTENANCE

The holder of a Pilot Certificate issued under FAR Part 61 may perform certain preventive maintenance described in FAR Part 43. This maintenance may be performed only on an aircraft which the pilot owns or operates and which is not used to carry persons or property for hire. Although such maintenance is allowed by law, each individual should make a self-analysis as to whether he has the ability to perform the work.

All other maintenance required on the airplane should be accomplished by appropriately licensed personnel.

If maintenance is accomplished, an entry must be made in the appropriate logbook. The entry should contain:

- (a) The date the work was accomplished.
- (b) Description of the work.
- (c) Number of hours on the aircraft.
- (d) The certificate number of pilot performing the work.
- (e) Signature of the individual doing the work.

8.7 AIRPLANE ALTERATIONS

If the owner desires to have his aircraft modified, he must obtain FAA approval for the alteration. Major alterations accomplished in accordance with Advisory Circular 43.13-2, when performed by an A & P mechanic, may be approved by the local FAA office. Major alterations to the basic airframe or systems not covered by AC 43.13-2 require a Supplemental Type Certificate.

The owner or pilot is required to ascertain that the following Aircraft Papers are in order and in the aircraft.

- (a) To be displayed in the aircraft at all times:
 - (1) Aircraft Airworthiness Certificate Form FAA-8100-2.
 - (2) Aircraft Registration Certificate Form FAA-8050-3.
 - (3) Aircraft Radio Station License if transmitters are installed.

- (b) To be carried in the aircraft at all times:
 - (1) Pilot's Operating Handbook.
 - (2) Weight and Balance data, plus a copy of the latest Repair and Alteration Form FAA-337, if applicable.
 - (3) Aircraft equipment list.

Although the aircraft and engine logbooks are not required to be in the aircraft, they should be made available upon request. Logbooks should be complete and up to date. Good records will reduce maintenance cost by giving the mechanic information about what has or has not been accomplished.

8.9 GROUND HANDLING

(a) Towing

The airplane may be moved on the ground by the use of the nose wheel steering bar that is stowed in the baggage compartment or by power equipment that will not damage or excessively strain the nose gear steering assembly.

CAUTIONS

When towing with power equipment, do not turn the nose gear beyond its steering radius in either direction, as this will result in damage to the nose gear and steering mechanism.

Do not tow the airplane when the controls are secured.

In the event towing lines are necessary, ropes should be attached to both main gear struts as high up on the tubes as possible. Lines should be long enough to clear the nose and / or tail by not less than fifteen feet, and a qualified person should ride in the pilot's seat to maintain control by use of the brakes.

(b) Taxiing

Before attempting to taxi the airplane, ground personnel should be instructed and approved by a qualified person authorized by the owner. Engine starting and shut-down procedures as well as taxi techniques should be covered. When it is ascertained that the propeller back blast and taxi areas are clear, power should be applied to start the taxi roll, and the following checks should be performed:

- (1) Taxi a few feet forward and apply the brakes to determine their effectiveness.
- (2) Taxi with the propeller set in low pitch, high RPM setting.
- (3) While taxiing, make slight turns to ascertain the effectiveness of the steering.

8.9 GROUND HANDLING (Continued)

- (4) Observe wing clearance when taxiing near buildings or other stationary objects. If possible, station an observer outside the airplane.
- (5) When taxiing over uneven ground, avoid holes and ruts.
- (6) Do not operate the engine at high RPM when running up or taxiing over ground containing loose stones, gravel, or any loose material that may cause damage to the propeller blades.

(c) Parking

When parking the airplane, be sure that it is sufficiently protected from adverse weather conditions and that it presents no danger to other aircraft. When parking the airplane for any length of time or overnight, it is suggested that it be moored securely.

- (1) To park the airplane, head it into the wind if possible.
- (2) Set the parking brake by depressing the toe brakes and pulling out the parking brake control. To release the parking brake, depress the toe brakes and push in the parking brake control, then release the toe brakes.

CAUTION

Care should be taken when setting brakes that are overheated or during cold weather when accumulated moisture may freeze a brake.

- (3) Aileron and stabilator controls should be secured with the front seat belt and chocks used to properly block the wheels.

(d) Mooring

The airplane should be moored for immovability, security and protection. The following procedures should be used for the proper mooring of the airplane:

- (1) Head the airplane into the wind if possible.
- (2) Retract the flaps.
- (3) Immobilize the ailerons and stabilator by looping the seat belt through the control wheel and pulling it snug.
- (4) Block the wheels.

- (5) Secure tie-down ropes to the wing tie-down rings and to the tail skid at approximately 45 degree angles to the ground. When using rope of non-synthetic material, leave sufficient slack to avoid damage to the airplane should the ropes contract.

CAUTION

Use bowline knots, square knots or locked slip knots. Do not use plain slip knots.

NOTE

Additional preparations for high winds include using tie-down ropes from the landing gear forks and securing the rudder.

- (6) Install a pitot head cover if available. Be sure to remove the pitot head cover before flight.
- (7) Cabin and baggage doors should be locked when the airplane is unattended.

8.11 ENGINE INDUCTION AIR FILTERS

(a) Removing Induction Air Filter

- (1) Remove the upper cowling to gain access to the air filter box.
- (2) Turn the three studs and remove the air filter box cover.
- (3) Lift the air filter from the filter box.

(b) Cleaning Induction Air Filters

The induction air filters must be cleaned at least once every 50 hours, and more often, even daily, when operating in dusty conditions. Extra filters are inexpensive, and a spare should be kept on hand for use as a rapid replacement.

8.11 ENGINE INDUCTION AIR FILTERS (Continued)

To clean the filter:

- (1) Tap filter gently to remove dirt particles. Do not use compressed air or cleaning solvents.
 - (2) Inspect filter. If paper element is torn or ruptured or gasket is damaged, the filter should be replaced. The usable life of the filter should be restricted to one year or 500 hours, whichever comes first.
- (c) Installation of Induction Air Filters

After cleaning, place filter in air box and install cover. Secure cover by turning studs. Replace cowl.

8.13 BRAKE SERVICE

The brake system is filled with MIL-H-5606 (petroleum base) hydraulic brake fluid. This should be checked periodically or at every 50-hour inspection and replenished when necessary. The brake reservoir is located in the forward maintenance area. Remove the four screws and rotate the fiberglass nose cone forward and down. The reservoir is located at the top rear of the compartment. Keep the fluid level at the level marked on the reservoir.

No adjustment of brake clearance is necessary. Refer to the Maintenance Manual for brake lining replacement instructions.

8.15 LANDING GEAR SERVICE

Two jack points are provided for jacking the aircraft for servicing. One is located outboard of each main landing gear. Before jacking, attach a tail support to the tail skid. Approximately 500 pounds of ballast should be placed on the tail support.

CAUTION

Be sure to apply sufficient support ballast; otherwise the airplane may tip forward, and the nose section could be damaged.

Landing gear oleos should be serviced according to instruction on the units. Under normal static load (empty weight of airplane plus full fuel and oil), main oleo struts should be exposed 2.60 inches and the nose oleo strut should be exposed 2.70 inches. Refer to the Maintenance Manual for complete information on servicing oleo struts.

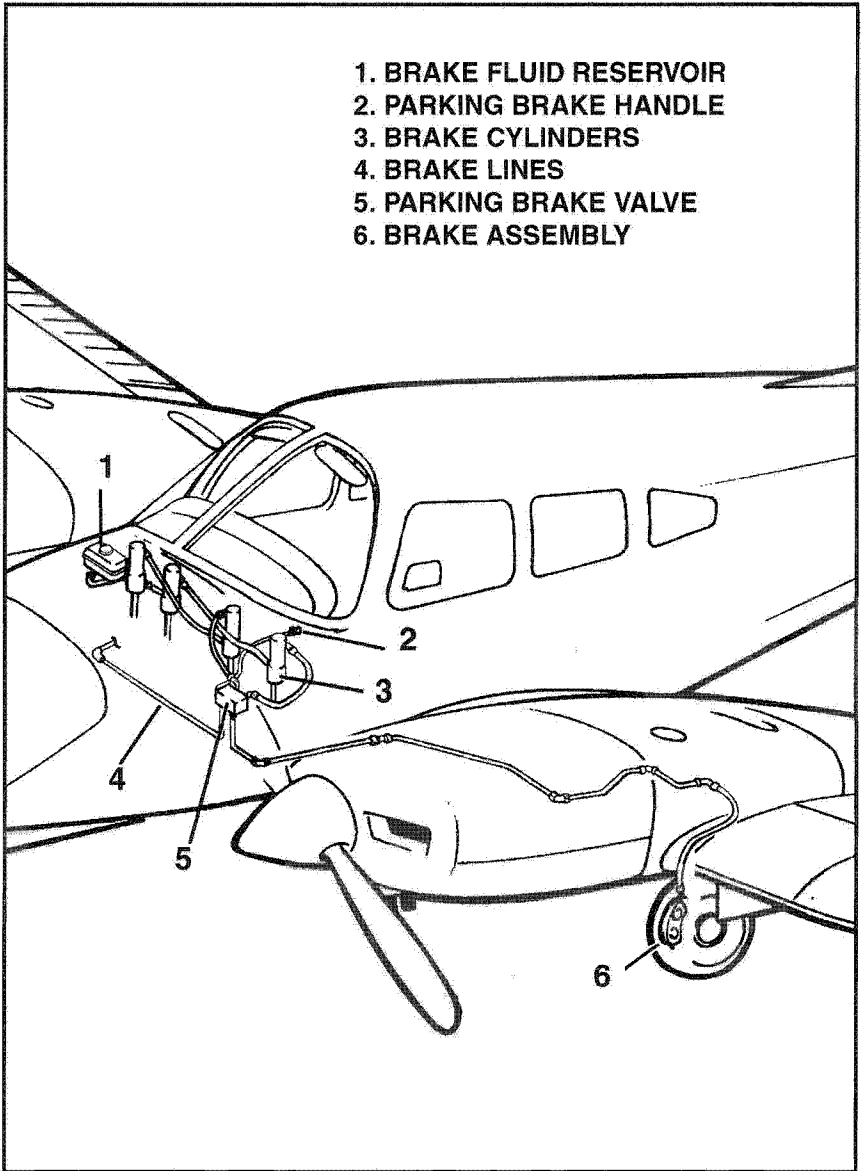

BRAKE SYSTEM

Figure 8-1

8.17 HYDRAULIC SYSTEM SERVICE

The hydraulic landing gear system reservoir is an integral part of the electric hydraulic pump assembly. The combination pump and reservoir is accessible through a panel in the baggage compartment. Fill the reservoir with MIL-H-5606 hydraulic fluid. The fluid level should be checked periodically or every 50 hour inspection and replenished when necessary.

To check fluid level, remove the filler plug/dipstick and note fluid level on dipstick. The filler plug also incorporates a vent. When reinstalling filler plug, tighten to full tight then loosen 1 1/2 turns to allow proper venting. The instructions are also placarded on the pump reservoir.

8.19 PROPELLER SERVICE

The gas charge in the propeller cylinder should be kept at the pressure specified on the placard located in the spinner cap. The pressure in the cylinder will increase about one-third psi for every degree Fahrenheit increase in temperature. This effect should be considered when checking pressure. The charge maintained must be accurate and free of excessive moisture since moisture may freeze the piston during cold weather. Dry nitrogen gas is recommended.

**CHAMBER PRESSURE REQUIREMENTS WITH
TEMPERATURE FOR COUNTERWEIGHT TYPE PROPELLERS**

Temp. °F	Pressure (PSI)
FOR PROPELLER HUBS: HC-C2Y(K,R)-2CEUF AND HC-C2Y(K,R)-2CLEUF	
70 to 100	41 +/- 1
40 to 70	38 +/- 1
0 to 40	36 +/- 1
-30 to 0	33 +/- 1

NOTE: Do not check pressure or charge with propeller in feather position.

The gas charge in the unfeathering accumulators should be maintained at 90 - 100 PSI. It is important to use nitrogen only for this purpose since any moisture in the system may freeze and render it inoperative. Do not check this charge pressure while engine is running.

8.19 PROPELLER SERVICE (Continued)

The spinner and backing plate should be cleaned and inspected for cracks frequently. Before each flight the propeller should be inspected for nicks, scratches, or corrosion. If found, they should be repaired as soon as possible by a rated mechanic, since a nick or scratch causes an area of increased stress which can lead to serious cracks or the loss of a propeller tip. The back face of the blades should be painted when necessary with flat black paint to retard glare. To prevent corrosion, all surfaces should be cleaned and waxed periodically.

8.21 OIL REQUIREMENTS

The oil capacity of the Lycoming engines is 8 quarts per engine with a minimum safe quantity of 2 quarts per engine. It is necessary that oil be maintained at full for maximum endurance flights. It is recommended that engine oil be drained and renewed every 50 hours, or sooner under unfavorable conditions. Full flow cartridge type oil filters should be replaced each 50 hours of operation. The interval between oil and oil filter change is not to exceed four (4) months. Lycoming Service Bulletin No. 446 should be complied with each 50 hours, also. The following grades are required for temperatures:

Average Ambient Temperature	MIL-L-6082B SAE Grade	MIL-L-22851 Ashless Dispersant SAE Grades
All Temperatures	--	15W-50 or 20W-50
Above 80°F	60	60
Above 60°F	50	40 or 50
30°F to 90°F	40	40
0°F to 70°F	30	30, 40 or 20W-40
0°F to 90°F	20W50	20W50 or 15W50
Below 10°F	20	30 or 20W-30

When operating temperatures overlap indicated ranges, use the lighter grade oil.

NOTE

Refer to the latest issue of Lycoming Service Instruction 1014 (Lubricating Oil Recommendations) for further information.

8.23 FUEL SYSTEM

(a) Servicing Fuel System

The fuel screens in the strainers require cleaning at 50 hour or 90 day intervals, whichever occurs first. The fuel gascolator strainers are located in the fuselage under the rear seats. The fuel selector valves and the auxiliary pumps are in the wings adjacent to the nacelles.

(b) Fuel Requirements

The minimum aviation grade fuel for the PA-44-180 is 100. Since the use of lower grades can cause serious engine damage in a short period of time, the engine warranty is invalidated by the use of lower octanes.

Refer to the latest issue of Lycoming Service Instruction No. 1070 for additional information.

A summary of current grades as well as the previous fuel designations is shown in the following chart:

FUEL GRADE COMPARISON CHART

Previous Commercial Fuel Grades (ASTM-D910)			Current Commercial Fuel Grades (ASTM-D910-75)			Current Military Fuel Grades (MIL-G-5572E) Amendment No. 3		
Grade	Color	Max. TEL ml/U.S. gal	Grade	Color	Max. TEL ml/U.S. gal	Grade	Color	Max. TEL ml/U.S. gal
80/87	red	0.5	80	red	0.5	80/87	red	0.5
91/98	blue	2.0	*100LL	blue	2.0	none	none	none
100/130	green	3.0	100	green	**3.0	100/130	green	**3.0
115/145	purple	4.6	none	none	none	115/145	purple	4.6

* -Grade 100LL fuel in some overseas countries is currently colored green and designated as 100L.

** -Commercial fuel grade 100 and grade 100/130 (both of which are colored green) having TEL content of up to 4 ml/U.S. gallon are approved for use in all engines certificated for use with grade 100/130 fuel.

The operation of the aircraft is approved with an anti-icing additive in the fuel. When an anti-icing additive is used it must meet the specification MIL-1-27686, must be uniformly blended with the fuel while refueling, must not exceed 0.15% by volume of the refueled quantity, and to ensure its effectiveness should be blended at not less than 0.10% by volume. One and one half liquid ozs. per ten gallon of fuel would fall within this range. A blender supplied by the additive manufacturer should be used. Except for the information contained in this section, the manufacturer's mixing or blending instructions should be carefully followed.

CAUTION

Assure that the additive is directed into the flowing fuel stream. The additive flow should start after and stop before the fuel flow. Do not permit the concentrated additive to come in contact with the aircraft painted surfaces or the interior surfaces of the fuel tanks.

CAUTIONS

Some fuels have anti-icing additives preblended in the fuel at the refinery, so no further blending should be performed.

Fuel additive can not be used as a substitute for preflight draining of the fuel system.

(c) Filling Fuel Tanks

Observe all safety precautions required when handling gasoline. Fill the fuel tanks through the fillers located inside the access cover aft of the engine cowling on the outboard side of the nacelles. Each nacelle tank holds a maximum of 55 U.S. gallons. When using less than the standard 110 gallon capacity, fuel should be distributed equally between each side.

8.23 FUEL SYSTEM (Continued)

(d) Draining Fuel Strainers, Sumps and Lines

The aircraft is equipped with single point drains (Figure 8-3) which should be drained before the first flight of the day and after refueling, to check for fuel contamination. If contamination is found, fuel should be drained until the contamination stops. If contamination persists after draining fuel for a minute, contact a mechanic to check the fuel system.

Each half of the fuel system can be drained from a single point which is located just forward of the entrance step. Fuel selectors should be in the ON position during draining. The fuel drained should be collected in a transparent container and examined for contamination.

CAUTION

When draining fuel, be sure that no fire hazard exists before starting the engines.

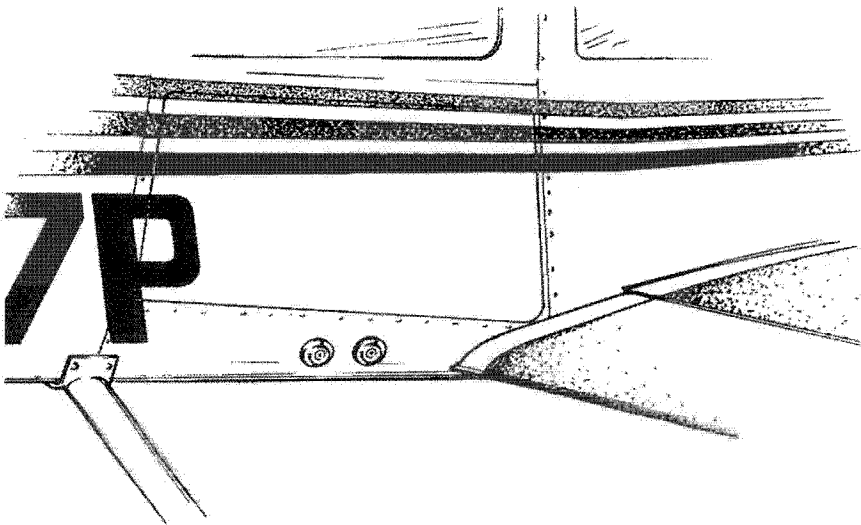

FUEL DRAINS

Figure 8-3

(e) Draining Fuel System

The fuel may be drained by opening the valves at the right hand side of the fuselage just forward of the entrance step or by siphoning. The remaining fuel in the lines may be drained through the gascolators.

8.25 TIRE INFLATION

For maximum service from the tires, keep them inflated to the proper pressures. The main gear tires should be inflated to 55 psi and the nose gear should be inflated to 50 psi.

Interchange the tires on the main wheels, if necessary, to produce even wear. All wheels and tires are balanced before original installation, and the relationship of the tire, tube, and wheel should be maintained if at all possible. Unbalanced wheels can cause extreme vibration on takeoff. In the installation of new components, it may be necessary to rebalance the wheel with the tire mounted.

When checking the pressure, examine the tires for wear, cuts, bruises and slippage.

8.27 BATTERY SERVICE

Access to the 12-volt 35 ampere hour battery is gained through the fiberglass nose cone. The battery container has a plastic drain tube which is normally closed off. This tube should be opened occasionally to drain off any accumulation of liquid.

The battery fluid level must not be brought above the baffle plates. It should be checked every 30 days to determine that the fluid level is proper and the connections are tight and free of corrosion. DO NOT fill the battery above the baffle plates. DO NOT fill the battery with acid - use distilled water only. A hydrometer check will determine the percent of charge in the battery.

If the battery is not properly charged, recharge it starting with a rate of 4 amperes and finishing with a rate of 2 amperes. Quick charges are not recommended.

8.27 BATTERY SERVICE (Continued)

The external power receptacle is located on the right side of the nose section. Be sure the Battery Master switch is OFF while inserting or removing a plug at this receptacle.

Refer to the Maintenance Manual for detailed procedures for cleaning and servicing the battery.

8.29 SERIAL NUMBER PLATES

The serial number plate is located on the left side of the fuselage near the aft end of the tail cone. The serial number should always be used when referring to the airplane on service or warranty matters.

8.31 LUBRICATION

Lubrication at regular intervals is an essential part of the maintenance of an airplane. For lubrication instructions and a chart showing lubrication points, types of lubricants to be used, lubrication methods and recommended frequencies, refer to the Maintenance Manual.

8.33 CLEANING

(a) Cleaning Engine Compartment

Before cleaning the engine compartment, place a strip of tape on the magneto vents to prevent any solvent from entering these units.

- (1) Place a large pan under the engine to catch waste.
- (2) With the engine cowling removed, spray or brush the engine with solvent or a mixture of solvent and degreaser. In order to remove especially heavy dirt and grease deposits, it may be necessary to brush areas that were sprayed.

CAUTION

Do not spray solvent into the alternator, vacuum pump, starter, air intakes, or alternate air inlets.

- (3) Allow the solvent to remain on the engine from five to ten minutes. Then rinse the engine clean with additional solvent and allow it to dry.

CAUTION

Do not operate the engine until excess solvent has evaporated or otherwise been removed.

- (4) Remove the protective tape from the magnetos.
 - (5) Lubricate the controls, bearing surfaces, etc., in accordance with the Lubrication Chart in the Maintenance Manual.
- (b) Cleaning Landing Gear

Before cleaning the landing gear, place a plastic cover or similar material over the wheel and brake assembly.

- (1) Place a pan under the gear to catch waste.
- (2) Spray or brush the gear area with solvent or a mixture of solvent and degreaser, as desired. Where heavy grease and dirt deposits have collected, it may be necessary to brush areas that were sprayed, in order to clean them.
- (3) Allow the solvent to remain on the gear from five to ten minutes. Then rinse the gear with additional solvent and allow to dry.
- (4) Remove the cover from the wheel and remove the catch pan.
- (5) Lubricate the gear in accordance with the Lubrication Chart in the Maintenance Manual.
- (6) Caution: Do not brush the micro switches.

(c) Cleaning Exterior Surfaces

The airplane should be washed with a mild soap and water. Harsh abrasives or alkaline soaps or detergents could make scratches on painted or plastic surfaces or could cause corrosion of metal. Cover areas where cleaning solution could cause damage. To wash the airplane, use the following procedure:

- (1) Flush away loose dirt with water.
- (2) Apply cleaning solution with a soft cloth, a sponge or a soft bristle brush.

8.33 CLEANING (Continued)

- (3) To remove exhaust stains, allow the solution to remain on the surface longer.
- (4) To remove stubborn oil and grease, use a cloth dampened with naphtha.
- (5) Rinse all surfaces thoroughly.
- (6) Any good automotive wax may be used to preserve painted surfaces. Soft cleaning cloths or a chamois should be used to prevent scratches when cleaning or polishing. A heavier coating of wax on the leading surfaces will reduce the abrasion problems in these areas.

(d) Cleaning Windshield and Windows

- (1) Remove dirt, mud and other loose particles from exterior surfaces with clean water.
- (2) Wash with mild soap and warm water or with aircraft plastic cleaner. Use a soft cloth or sponge in a straight back and forth motion. Do not rub harshly.
- (3) Remove oil and grease with a cloth moistened with kerosene.

CAUTION

Do not use gasoline, alcohol, benzene, carbon tetrachloride, thinner, acetone, or window cleaning sprays.

- (4) After cleaning plastic surfaces, apply a thin coat of hard polishing wax. Rub lightly with a soft cloth. Do not use a circular motion.
- (5) A severe scratch or mar in plastic can be removed by rubbing out the scratch with jeweler's rouge. Smooth both sides and apply wax.

(e) Cleaning Headliner, Side Panels and Seats

- (1) Clean headliner, side panels, and seats with a stiff brush, and vacuum where necessary.
- (2) Soiled upholstery, except leather, may be cleaned with a good upholstery cleaner suitable for the material. Carefully follow the manufacturer's instructions. Avoid soaking or harsh rubbing.

CAUTION

Solvent cleaners require adequate ventilation.

- (3) Leather should be cleaned with saddle soap or a mild hand soap and water.

(f) Cleaning Carpets

To clean carpets, first remove loose dirt with a whisk broom or vacuum. For soiled spots and stubborn stains use a non-inflammable dry cleaning fluid. Floor carpets may be removed and cleaned like any household carpet.

8.35 WINTERIZATION

For winter operation a winterization kit is installed on the inlet opening of the oil cooler outboard chamber of the plenum chamber. This kit should be installed whenever the ambient temperature is 50°F or less. When the kit is not being used it can be stowed in the nose cone compartment.

THIS PAGE INTENTIONALLY LEFT BLANK

TABLE OF CONTENTS

SECTION 9
SUPPLEMENTS

Paragraph/Supplement No.		Page No.
9.1	General	9-1
1	King KFC 150 Series Flight Control System(1 Page) (Pages 9-4 thru 9-24 DELETED)	9-3
2	King KNS-81 Area Navigation System.....(6 Pages)	9-25
3	Bendix/King KLN 89B GPS Navigation System.....(12 Pages)	9-31
4	Bendix/King KLN 90B GPS Navigation System.....(12 Pages)	9-43
5	Bendix/King KX 155A Comm / Nav System(12 Pages)	9-55
6	Garmin GNS 430 VHF Comm/Nav/GPS(8 pages)	9-67
7	S-TEC System 55 Autopilot.....	9-75
8	S-TEC Manual Electric Trim System.....	9-77
9	Airline Transport Professionals Seminoles(4 pages)	9-79
10	Garmin GTX 327 Transponder(10 pages)	9-83
11	S-TEC System 55X Autopilot.....	9-93
12	S-TEC ADF 650A System(6 pages)	9-95
13	Garmin GMA 340 Audio Panel(6 pages)	9-101
14	S-TEC DME 450.....(4 pages)	9-107
15	B.F. Goodrich Aerospace WX-500 Stormscope - Series II Weather Mapping Sensor(4 pages)	9-111
16	S-TEC ADF 650D System(10 pages)	9-115
17	Garmin GTX 330 Transponder(4 pages)	9-125

THIS PAGE INTENTIONALLY LEFT BLANK

SECTION 9

SUPPLEMENTS

9.1 GENERAL

This section provides information in the form of Supplements which are necessary for efficient operation of the airplane when equipped with one or more of the various optional systems and equipment not approved with the standard airplane.

All of the supplements provided in this section are FAA Approved and consecutively numbered as a permanent part of this Handbook. The information contained in each Supplement applies only when the related equipment is installed in the airplane.

THIS PAGE INTENTIONALLY LEFT BLANK

**PILOT'S OPERATING HANDBOOK
SUPPLEMENT NO. 1
FOR
KING KFC 150 SERIES FLIGHT CONTROL SYSTEM**

This supplement has been DELETED as the FAA Approved Operational Supplement to the Bendix/King 150 Series Flight Control System as installed per STC SA2321CE-D. Effective this revision Bendix/King will be responsible to supply and revise the operational supplement. It is permitted to include the Bendix/King supplement in this location of the Pilot's Operating Handbook unless otherwise stated by Bendix/King.

THIS PAGE INTENTIONALLY LEFT BLANK

**PILOT'S OPERATING HANDBOOK
AND
FAA APPROVED AIRPLANE FLIGHT MANUAL**

**SUPPLEMENT NO. 2
FOR
BENDIX/KING KNS 81 DIGITAL AREA NAVIGATION SYSTEM**

This supplement must be attached to the Pilot's Operating Handbook and FAA Approved Airplane Flight Manual when the optional King KNS 81 Navigation System is installed per the Equipment List. The information contained herein supplements or supersedes the information in the basic Pilot's Operating Handbook and FAA Approved Airplane Flight Manual only in those areas listed herein. For limitations, procedures and performance information not contained in this supplement, consult the basic Pilot's Operating Handbook and FAA Approved Airplane Flight Manual.

FAA APPROVED:



PETER E. PECK
D.O.A. NO. SO-1
THE NEW PIPER AIRCRAFT, INC.
VERO BEACH, FLORIDA

DATE OF APPROVAL: JULY 12, 1995

SECTION 1 - GENERAL

This supplement supplies information necessary for the operation of the airplane when the optional King KNS 81 Digital Area Navigation System is installed in accordance with FAA Approved Piper data.

SECTION 2 - LIMITATIONS

No changes to the basic limitations provided by Section 2 of this Pilot's Operating Handbook are necessary for this supplement.

SECTION 3 - EMERGENCY PROCEDURES

No changes to the basic Emergency Procedures provided by Section 3 of this Pilot's Operating Handbook are necessary for this supplement.

SECTION 4 - NORMAL PROCEDURES

(a) **KNS 81 OPERATION**

The KNS 81 can be operated in any one of 3 modes:

- (a) VOR
- (b) RNAV
- (c) ILS

To change from one mode to another, the mode select knob is rotated (large knob on the left side of the panel), except that the ILS mode is entered automatically whenever an ILS frequency is channeled. The display will annunciate the VOR or RNAV mode by lighting a message beside the waypoint.

In addition to the standard VOR and RNAV enroute (RNV ENR) modes, the KNS 81 has a constant course width or parallel VOR mode (VOR PAR) and an RNAV approach mode (RNV APR). To place the unit in either of these secondary modes the mode selector knob is rotated.

(b) CONTROLS

(1) USE BUTTON

Momentary pushbutton.

Causes displayed waypoint to become active waypoint and carrot display to go to FRQ mode.

(2) RTN BUTTON

Momentary pushbutton.

When pushed causes waypoint in use to be displayed and carrot display to go to FRQ mode.

(3) RAD BUTTON

Two position pushbutton.

The KNS 81 is normally operated with the RAD button not pressed.

When in depressed position causes DME to display radial information instead of ground speed. Radial displayed will be from the station in VOR mode and from the waypoint in RNAV modes.

(4) CHK BUTTON

Momentary pushbutton.

Causes radial and distance waypoint parameters to show radial and distance from VOR station instead.

(5) DATA BUTTON

Momentary pushbutton.

Causes waypoint data display to change from FRQ to RAD to DST and back to FRQ.

(6) OFF/ ON/ IDENT CONTROL

a. Power OFF-ON/Volume Function - Rotate clockwise for power ON.

b. VOR Audio Level Control - Rotate clockwise for increased audio level.

c. VOR IDENT Mute Function - Push-Pull switch. Enables the VOR Ident tone to be heard in out position.

SECTION 4- NORMAL PROCEDURES (Continued)

(7) DATA INPUT CONTROL

Dual concentric knobs, right side of panel - Center knob has in and out positions.

a. Frequency Data

Outer knob varies 1 MHz digit.

A carry occurs from units to tens position.

Rollover occurs from 117 to 108.

Center knob varies frequency in 50KHz steps (IN or OUT position).

b. Radial Data

Outer knob varies 10 degree digit.

A carry occurs from the tens to hundreds position.

A rollover to zero occurs at 360 degrees.

Center knob in position varies 1 degree digit.

Center knob out position varies 0.1 degree digit.

c. Distance Data

Outer knob varies 10 NM digit.

A carry occurs from the tens to hundreds place.

A rollover to zero occurs at 200 NM.

Center knob in position varies 1 NM digit.

Center knob out position varies 0.1 NM digit.

(8) DUAL CONCENTRIC KNOBS, LEFT SIDE OF PANEL

a. Mode Select

Outer knob changes mode from VOR to VOR PAR to RNV to RNV APR and rolls over.

b. WPT Select

Center knob selects waypoint from 1 to 9 and rolls over.

(9) COURSE SELECT KNOB

Located in remote unit.

Selects desired course through the VOR ground station or waypoint.

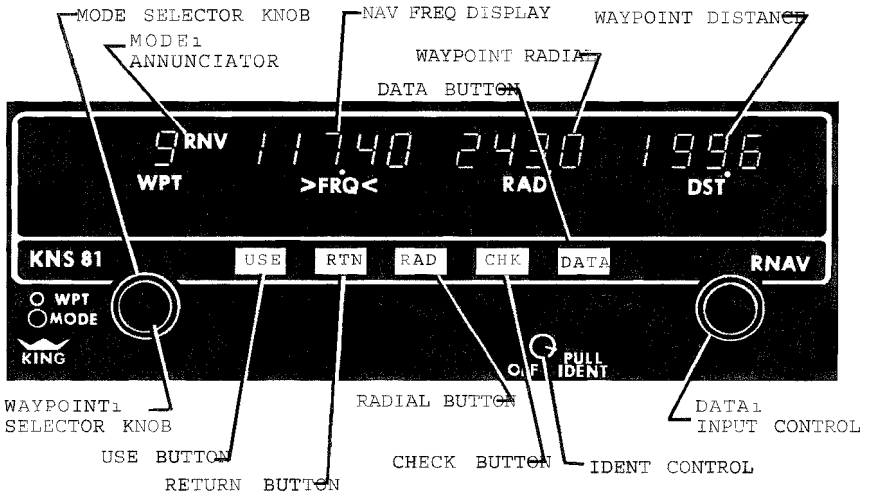

KNS 81 DIGITAL AREA NAVIGATION SYSTEM

Figure 4-1

SECTION 5 - PERFORMANCE

No changes to the basic performance provided by Section 5 of this Pilot's Operating Handbook are necessary for this supplement.

THIS PAGE INTENTIONALLY LEFT BLANK

**PILOT'S OPERATING HANDBOOK
AND
FAA APPROVED AIRPLANE FLIGHT MANUAL**

**SUPPLEMENT NO. 3
FOR
BENDIX/KING KLN 89B GPS
NAVIGATION SYSTEM**

This supplement must be attached to the Pilot's Operating Handbook and FAA Approved Airplane Flight Manual when the KLN 89B GPS Navigation System is installed per the Equipment List. The information contained herein supplements or supersedes the Pilot's Operating Handbook and FAA Approved Airplane Flight Manual only in those areas listed herein. For limitations, procedures and performance information not contained in this supplement, consult the Pilot's Operating Handbook and FAA Approved Airplane Flight Manual.

FAA APPROVED:



PETER E. PECK
D.O.A. NO. SO-1
THE NEW PIPER AIRCRAFT, INC.
VERO BEACH, FLORIDA

DATE OF APPROVAL: October 25, 1995

SECTION 1 GENERAL

The KLN 89B GPS panel mounted unit contains the GPS sensor, the navigation computer, a CRT display, and all controls required to operate the unit. It also houses the data base card which plugs directly into the front of the unit.

The data base card is an electronic memory containing information on airports, navaids, intersections, SID's, STAR's, instrument approaches, special use airspace, and other items of value to the pilot.

Every 28 days, Bendix/King receives new data base information from Jeppesen Sanderson for the North American data base region. This information is processed and downloaded onto the data base cards. Bendix/King makes these data base card updates available to KLN 89B GPS users.

Provided the KLN 89B GPS navigation system is receiving adequate usable signals, it has been demonstrated capable of and has been shown to meet the accuracy specifications of:

VFR/IFR en route oceanic and remote, en route domestic, terminal, and instrument approach (GPS, Loran-C, VOR, VOR-DME, TACAN, NDB, NDB-DME, RNAV) operation within the U.S. National Airspace System, North Atlantic Minimum Navigation Performance Specifications (MNPS) Airspace and latitudes bounded by 74° North and 60° South using the WGS44 (or NAD 83) coordinate reference datum in accordance with the criteria of AC 20-138, AC 91-49, and AC 120-33. Navigation data is based upon use of only the global positioning system (GPS) operated by the United States.

NOTE

Aircraft using GPS for oceanic IFR operations may use the KLN 89B to replace one of the other approved means of long-range navigation. A single KLN 89B GPS installation may also be used on short oceanic routes which require only one means of longrange navigation.

NOTE

FAA approval of the KLN 89B does not necessarily constitute approval for use in foreign airspace.

SECTION 2- LIMITATIONS

A. The KLN 89B GPS Pilot's Guide, P/N 006-08786-0000, dated May, 1995 (or later applicable revision) must be immediately available to the flight crew whenever navigation is predicated on the use of the system. The Operational Revision Status (ORS) of the Pilot's Guide must match the ORS level annunciated on the Self Test page.

B. IFR Navigation is restricted as follows:

1. The system must utilize ORS level 01 or later FAA approved revision.
2. The data on the self test page must be verified prior to use.
3. IFR en route and terminal navigation is prohibited unless the pilot verifies the currency of the data base or verifies each selected waypoint for accuracy by reference to current approved data.
4. Instrument approaches must be accomplished in accordance with approved instrument approach procedures that are retrieved from the KLN 89B data base. The KLN 89B data base must incorporate the current update cycle.
 - (a) The KLN 89B Quick Reference, P/N 006-08787-0000, dated 5/95 (or later applicable revision) must be immediately available to the flight crew during instrument approach operations.
 - (b) Instrument approaches must be conducted in the approach mode and RAIM must be available at the Final Approach Fix.
 - (c) APR ACTV mode must be annunciated at the Final Approach Fix.
 - (d) Accomplishment of ILS, LOC, LOC-BC, LDA, SDF, and MLS approaches are not authorized.
 - (e) When an alternate airport is required by the applicable operating rules, it must be served by an approach based on other than GPS or Loran-C navigation.
 - (f) The KLN 89B can only be used for approach guidance if the reference coordinate datum system for the instrument approach is WGS 84 or NAD-83. (All approaches in the KLN 89B data base use the WGS-84 or the NAD-83 geodetic datums.)
5. The aircraft must have other approved navigation equipment appropriate to the route of flight installed and operational.

**SECTION 3- EMERGENCY PROCEDURES
ABNORMAL PROCEDURES**

- A. If the KLN 89B GPS information is not available or invalid, utilize remaining operational navigation equipment as required.
- B. If a "RAIM NOT AVAILABLE" message is displayed while conducting an instrument approach, terminate the approach. Execute a missed approach if required.
- C. If a "RAIM NOT AVAILABLE" message is displayed in the en route or terminal phase of flight, continue to navigate using the KLN 89B or revert to an alternate means of navigation appropriate to the route and phase of flight. When continuing to use GPS navigation, position must be verified every 15 minutes using another IFR approved navigation system.
- D. Refer to the KLN 89B Pilot's Guide, Appendices B and C, for appropriate pilot actions to be accomplished in response to annunciated messages.

SECTION 4 - NORMAL PROCEDURES

WARNING

Familiarity with the en route operation of the KLN 89B does not constitute proficiency in approach operations. Do not attempt approach operations In IMC prior to attaining proficiency in the use of the KLN 89B.

A. OPERATION

Normal operating procedures are outlined in the KLN 89B GPS Pilot's Guide, P/N 006-08786-0000, dated May 1995, (or later applicable revision). A KLN 89B Quick Reference, P/N 006-08787-0000 dated 5/ 95 (or later applicable revision) containing an approach sequence, operating bps and approach related messages is intended for cockpit use by the KLN 89B familiar pilot when conducting instrument approaches.

B. SYSTEM ANNUNCIATORS/SWITCHES/CONTROLS

- 1. HSI NAV presentation (**NAV/GPS**) switch annunciator- May be used to select data for presentation on the pilot's HSI; either NAV data from the number one navigation receiver or GPS data from the KLN 89B GPS. Presentation on the HSI is also required for autopilot coupling. **NAV** is green. **GPS** is blue.

NORMAL PROCEDURES

2. Message (MSG) annunciator - Will flash to alert the pilot of a situation that requires attention. Press the MSG button on the KLN 89B GPS to view the message. (Appendix B of the KLN 89B Pilot's Guide contains a list of all of the message page messages and their meanings). **MSG** is amber.
3. Waypoint (WPT) annunciator - Prior to reaching a waypoint in the active flight plan, the KLN 89B GPS will provide navigation along a curved path segment to ensure a smooth transition between two adjacent legs in the flight plan. This feature is called turn anticipation. Approximately 20 seconds prior to the beginning of turn anticipation the WPT annunciator will flash, going solid upon initialization of the turn, and extinguishing upon turn completion. **WPT** is amber.

WARNING

Turn anticipation is automatically disabled for FAF waypoints and those used exclusively in SID/STARS where overflight is required. For waypoints shared between SID/STARS and published en route segments (requiring overflight in the SID/ STARS), proper selection on the presented waypoint page is necessary to provide adequate route protection on the SID/STARS.

4. HSI course control  knob - Provides analog course input to the KLN 89B in **OBS** when the NAV/GPS switch/annunciator is in **GPS**. When the NAV/GPS switch annunciation is in **NAV**, GPS course selection in **OBS** mode is digital through the use of the controls and display at the KLN 89B. The HSI course control knob must also be set to provide proper course datum to the autopilot if coupled to the KLN 89B in **LEG** or **OBS**.

NOTE

Manual **HSI** course centering in **OBS** using the control knob can be difficult, especially at long distances. Centering the dbar can best be accomplished by pressing  and then manually setting the HSI pointer to the course value prescribed in the KLN 89B displayed message.

NORMAL PROCEDURES

5. GPS approach (**GPS APR ARM/ACTV**) switch/annunciator - Used to (a) manually select or deselect approach **ARM** (or deselect approach **ACTV**) and (b) annunciate the stage of approach operation either armed (**ARM**) or activated (**ACTV**). Sequential button pushes if in **ACTV** would first result in approach **ARM** and then approach arm canceled. Subsequent button pushes will cycle between the armed state (if an approach is in the flight plan) and approach arm canceled. Approach **ACTV** cannot be selected manually. **GPS APR** and **ARM** are white. **ACTV** is green.
6. RMI NAV presentation switch - May be used to select data for presentation on the RMI; either **NAV 1** data from the number one navigation receiver, **NAV 2** data from the number two navigation receiver or **GPS** data from the **KLN 89B GPS**.

C. PILOTS DISPLAY

Left/right steering information is presented on the pilot's HSI as a function of the NAV/GPS switch position.

D. AUTOPILOT COUPLED OPERATION

The **KLN 89B** may be coupled to the autopilot by first selecting **GPS** on the NAV/GPS switch. Manual selection of the desired track on the pilot's HSI course pointer is required to provide course datum to the autopilot. (Frequent manual course pointer changes may be necessary, such as in the case of flying a **DME arc**.) The autopilot approach mode (**APR**) should be used when conducting a coupled **GPS** approach.

NOTE

Select HDG mode for DME arc intercepts. NAV or APR coupled **DME arc** intercepts can result in excessive overshoots (aggravated by high ground speeds and/or intercepts from inside the arc).

NORMAL PROCEDURES

E. ALTITUDE ALERT AURAL TONES r

1000 feet prior to reaching the selected altitude - three short tones.

Upon reaching the selected altitude - two short tones.

Deviating above or below the selected altitude by more than the warn altitude - four short tones.

F. APPROACH MODE SEQUENCING AND RAIM PREDICTION

NOTE

The special use airspace alert will automatically be disabled prior to flying an instrument approach to reduce the potential for message congestion.

1. Prior to arrival, select a **STAR** if appropriate from the **APT 7** page. Select an approach and an initial approach fix (IAF) from the **APT 8** page.

NOTES

Using the outer knob, select the **ACT (Active Flight Plan Waypoints)** pages. Pull the inner knob out and scroll to the destination airport, then push the inner knob in and select the **ACT 7** or **ACT 8** page.

To delete or replace a **SID**, **STAR** or approach, select **FPL 0** page. Place the cursor over the name of the procedure, press **ENT** to change it, or **CLR** then **ENT** to delete it.

2. En route, check for **RAIM** availability at the destination airport **ETA** on the **OTH 3** page.

NOTE

RAIM must be available at the **FAF** in order to fly an instrument approach. Be prepared to terminate the approach upon loss of **RAIM**.

NORMAL PROCEDURES

3. At 30 nm from the airport:
 - a. Verify automatic annunciation of **APR ARM**.
 - b. Note automatic dbar scaling change from ± 5.0 nm to ± 1.0 nm over the next 30 seconds.
 - c. Update the KLN 89B altimeter baro setting as required.
 - d. Internally the KLN 89B will transition from en route to terminal integrity monitoring.
4. Select NAV 4 page to fly the approach procedure.
 - a. If receiving radar vectors, or need to fly a procedure turn or holding pattern, fly in OBS until inbound to the FAF.

NOTE

OBS navigation is TO-FROM (like a VOR) without waypoint sequencing.

- b. NoPT routes including DME arc's are flown in **LEG**. LEG is mandatory from the FAF to the MAP.

NOTE

Select HDG mode for DME arc intercepts. NAV or APR coupled DME arc intercepts can result in excessive overshoots (aggravated by high ground speeds and/or intercepts from inside the arc).

WARNING

Flying final outbound from an off airport vortac on an overlay approach; beware of the DME distance increasing on final approach, and the GPS distance-to waypoint decreasing, and not matching the numbers on the approach plate!

5. At or before 2 nm from the FAF inbound:
 - a. Select the FAF as the active waypoint, if not accomplished already.
 - b. Select LEG operation.

NORMAL PROCEDURES

6. Approaching the FAF inbound (within 2 nm.):
 - a. Verify **APR ACTV**.
 - b. Note automatic dbar scaling change from ± 1.0 nm to ± 0.3 nm over the 2 nm inbound to the FAF.
 - c. Internally the KLN 89B will transition from terminal to approach integrity monitoring.
7. Crossing the FAF and **APR ACTV** is not annunciated:
 - a. Do not descend.
 - b. Execute the missed approach.
8. Missed Approach:
 - a. Climb
 - b. Navigate to the MAP (in **APR ARM** if **APR ACTV** is not available).

NOTE

There is no automatic **LEG** sequencing at the **MAP**.

- c. After climbing in accordance with the published missed approach procedure, press  verify or change the desired holding fix and press **ENT**.

GENERAL NOTES

- The data base must be up to date for instrument approach operation.
- Only one approach can be in the flight plan at a time.
- If the destination airport is the active waypoint at the time of the instrument approach selection, the active waypoint will shift automatically to the chosen IAF.
- Checking **RAIM** prediction for your approach while en route using the **OTH 3** page is recommended. A self check occurs automatically within 2 nm of the FAF. **APR ACTV** is inhibited without **RAIM**.
- Data cannot be altered, added to or deleted from the approach procedures contained in the data base. (DME arc intercepts may be relocated along the arc through the **NAV4** or the **FPL 0** pages).
- Some approach waypoints do not appear on the approach plates (including in some instances the FAF)!

NORMAL PROCEDURES

- Waypoint suffixes in the flight plan:
 - i - IAF
 - f - FAF
 - m - MAP
 - h missed approach holding fix.
- The DME arc IAF (arc intercept waypoint) will be a) on your present position radial off the arc VOR when you load the IAF into the flight plan, or b) the beginning of the arc if currently on a radial beyond the arc limit. To adjust the arc intercept to be compatible with a current radar vector, bring up the arc IAF waypoint in the **NAV 4** page scanning field or under the cursor on the **FPL 0** page, press **CLR**, then **ENT**. Fly the arc in **LEG**. adjust the HSI or CDI course pointer with reference to the desired track value on the **NAV 4** page (it will flash to remind you). Left/right dbar information is relative to the arc. Displayed distance is not along the arc but **direct** to the active waypoint. (The **ARC** radial is also displayed in the lower right corner of the **NAV 4** page.)
- The DME arc IAF identifier may be unfamiliar. Example: D098G where 098 stands for the 098° radial off the referenced VOR, and G is the seventh letter in the alphabet indicating a 7 DME arc.

NORMAL PROCEDURES

APR **ARM** to APR **ACTV** is automatic provided:

- a. You are in APR **ARM** (normally automatic).
- b. You are in LEG mode!
- c. The FAF is the active waypoint!
- d. Within 2 n.m. of the FAF.
- e. Outside of the FAF.
- f. Inbound to the FAF.
- g. RAIM is available.

Direct-To operation between the FAF and MAP cancels APR **ACTV**. Fly the missed approach in APR **ARM**.

Flagged navigation inside the FAF may usually be restored (not guaranteed) by pressing the GPS APR button changing from **ACTV** to **ARM**. Fly the missed approach.

The instrument approach using the KLN 89B may be essentially automatic starting 30 nm out (with a manual baro setting update) or it may require judicious selection of the OBS and LEG modes.

APR **ARM** may be canceled at any Time by pressing the GPS APR button. (A subsequent press will reselect it.)

SECTION 5- PERFORMANCE

No change.

SECTION 6- WEIGHT AND BALANCE

Factory installed optional equipment is included in the licensed weight and balance data in Section 6 of the Basic Pilot's Operating Handbook.

THIS PAGE INTENTIONALLY LEFT BLANK

**PILOT'S OPERATING HANDBOOK
AND
FAA APPROVED AIRPLANE FLIGHT MANUAL
SUPPLEMENT NO. 4
FOR
BENDIX/KING KLN 90B GPS
NAVIGATION SYSTEM WITH
KAP/KFC 150 AUTOPILOT SYSTEM**

This supplement must be attached to the Pilot's Operating Handbook and FAA Approved Airplane Flight Manual when the optional Bendix/King KLN 90B GPS Navigation System is installed per Equipment List. The information contained herein supplements or supersedes the information in the basic Pilot's Operating Handbook and FAA Approved Airplane Flight Manual only in those areas listed herein. For limitations, procedures and performance information not contained in this supplement, consult the basic Pilot's Operating Handbook and FAA Approved Airplane Flight Manual.

FAA APPROVED



PETER E. PECK
D.O.A. NO. SO.-1
THE NEW PIPER AIRCRAFT, INC.
VERO BEACH, FLORIDA

DATE OF APPROVAL JANUARY 9, 1996

SECTION 1 - GENERAL

The KLN 90B GPS panel mounted unit contains the GPS sensor, the navigation computer, a CRT display, and all controls required to operate the unit. It also houses the data base cartridge which plugs directly into the back of the unit.

The data base cartridge is an electronic memory containing information on airports, nav aids, intersections, SID's, STAR's, instrument approaches, special use airspace, and other items of value to the pilot.

Every 28 days, Bendix/King receives new data base information from Jeppesen Sanderson for the North American data base region. This information is processed and downloaded onto the data base cartridges. Bendix/King makes these data base cartridge updates available to KLN 90B GPS users.

Provided the KLN 90B GPS navigation system is receiving adequate usable signals, it has been demonstrated capable of and has been shown to meet the accuracy specifications of:

VFR/IFR en route oceanic and remote, en route domestic, terminal, and instrument approach (GPS, Loran-C, VOR, VOR-DME, TACAN, NDB, NDB-DME, RNAV) operation within the U.S. National Airspace System, North Atlantic Minimum Navigation Performance Specifications (MNPS) Airspace and latitudes bounded by 74° North and 60° South using the WGS-84 (or NAD 83) coordinate reference datum in accordance with the criteria of AC 20-138, AC 91-49, and AC 120-33. Navigation data is based upon use of only the global positioning system (GPS) operated by the United States.

NOTE:

Aircraft using GPS for oceanic IFR operations may use the KLN 90B to replace one of the other approved means of long-range navigation. A single KLN 90B GPS installation may also be used on short oceanic routes which require only one means of long range navigation.

NOTE:

FAA approval of the KLN 90B does not necessarily constitute approval for use in foreign airspace.

SECTION 2 - LIMITATIONS

- A. The KLN 90B GPS Pilot's Guide, P/N 006-08773-0000, dated December, 1994 (or later applicable revision) must be immediately available to the flight crew whenever navigation is predicated on the use of the system. The Operational Revision Status (ORS) of the Pilot's Guide must match the ORS level annunciated on the Self Test page.
- B. IFR Navigation is restricted as follows:
1. The system must utilize ORS level 20 or later FAA approved revision.
 2. The data on the self test page must be verified prior to use. Verify valid altitude data is available to the KLN 90B prior to flight.
 3. IFR en route and terminal navigation is prohibited unless the pilot verifies the currency of the data base or verifies each selected waypoint for accuracy by reference to current approved data.
 4. Instrument approaches must be accomplished in accordance with approved instrument approach procedures that are retrieved from the KLN 90B data base. The KLN 90B data base must incorporate the current update cycle.
 - (a) The KLN 90B Memory Jogger, P/N 006-08785-0000, dated 12/94 (or later applicable revision) must be immediately available to the flight crew during instrument approach operations.
 - (b) Instrument approaches must be conducted in the approach mode and RAIM must be available at the Final Approach Fix.
 - (c) APR ACTV mode must be annunciated at the Final Approach Fix.
 - (d) Accomplishment of ILS, LOC, LOC-BC, LDA, SDF, and MLS approaches are not authorized.
 - (e) When an alternate airport is required by the applicable operating rules, it must be served by an approach based on other than GPS or Loran-C navigation.
 - (f) The KLN 90B can only be used for approach guidance if the reference coordinate datum system for the instrument approach is WGS-84 or NAD-83. (All approaches in the KLN 90B data base use the WGS-84 or the NAD-83 geodetic datums.)
 5. The aircraft must have other approved navigation equipment appropriate to the route of flight installed and operational.

SECTION 3 - EMERGENCY PROCEDURES

ABNORMAL PROCEDURES

- A. If the KLN 90B GPS information is not available or invalid, utilize remaining operational navigation equipment as required.
- B. If a "RAIM NOT AVAILABLE" message is displayed while conducting an instrument approach, terminate the approach. Execute a missed approach if required.
- C. If a "RAIM NOT AVAILABLE" message is displayed in the en route or terminal phase of flight, continue to navigate using the KLN 90B or revert to an alternate means of navigation appropriate to the route and phase of flight. When continuing to use GPS navigation, position must be verified every 15 minutes using another IFR approved navigation system.
- D. Refer to the KLN 90B Pilot's Guide, Appendices B and C, for appropriate pilot actions to be accomplished in response to annunciated messages.

SECTION 4 - NORMAL PROCEDURES

WARNING:

Familiarity with the en route operation of the KLN 90B does not constitute proficiency in approach operations. Do not attempt approach operations in IMC prior to attaining proficiency in the use of the KLN 90B.

A. OPERATION

Normal operating procedures are outlined in the KLN 90B GPS Pilot's Guide, P/N 006-08773-0000, dated December, 1994, (or later applicable revision). A KLN 90B Memory Jogger, P/N 006-08785-0000 dated 12/94 (or later applicable revision) containing an approach sequence, operating tips and approach related messages is intended for cockpit use by the KLN 90B familiar pilot when conducting instrument approaches.

B. SYSTEM ANNUNCIATORS/SWITCHES/CONTROLS

- 1. HSI NAV presentation (NAV/GPS) switch annunciator - May be used to select data for presentation on the pilot's HSI; either NAV data from the number one navigation receiver or GPS data from the KLN 90B GPS. Presentation on the HSI is also required for autopilot coupling. NAV is green. GPS is blue.
- 2. Message (MSG) annunciator - Will flash to alert the pilot of a situation that requires attention. Press the MSG button on the KLN 90B GPS to view the message. (Appendix B of the KLN 90B Pilot's Guide contains a list of all of the message page messages and their meanings). MSG is amber.

SECTION 4 - NORMAL PROCEDURES (CONT'D)

3. Waypoint (WPT) annunciator - Prior to reaching a waypoint in the active flight plan, the KLN 90B GPS will provide navigation along a curved path segment to ensure a smooth transition between two adjacent legs in the flight plan. This feature is called turn anticipation. Approximately 20 seconds prior to the beginning of turn anticipation the WPT annunciator will flash, going solid upon initialization of the turn, and extinguishing upon turn completion. WPT is amber.

WARNING:

Turn anticipation is automatically disabled for FAF waypoints and those used exclusively in SID/STARS where overflight is required. For waypoints shared between SID/STARS and published en route segments (requiring overflight in the SID/STARS), proper selection on the presented waypoint page is necessary to provide adequate route protection on the SID/STARS.

4. GPS omni bearing or leg (GPS CRS OBS/LEG) course switch/annunciator - Used to select the basic modes of KLN 90B operation, either a) single waypoint with omni - bearing course (OBS) selection through that waypoint (like a VOR) or b) automatic leg sequencing (LEG) between waypoints. GPS CRS is white. OBS may either be white or amber. LEG is green.

NOTE:

Either LEG or OBS will illuminate during system self test depending upon switch position.

5. HSI course control ① knob - Provides analog course input to the KLN 90B in OBS when the NAV/GPS switch/annunciator is in GPS. When the NAV/GPS switch annunciation is in NAV, GPS course selection in OBS mode is digital through the use of the controls and display at the KLN 90B. The HSI course control knob must also be set to provide proper course datum to the autopilot if coupled to the KLN 90B in LEG or OBS.

SECTION 4 - NORMAL PROCEDURES (CONT'D)

NOTE

Manual HSI course centering in OBS using the control knob can be difficult, especially at long distances. Centering the dbar can best be accomplished by pressing [—D➤] and then manually setting the HSI pointer to the course value prescribed in the KLN 90B displayed message.

6. GPS approach (GPS APR ARM/ACTV) switch/annunciator - Used to a) manually select or deselect approach ARM (or deselect approach ACTV) and b) annunciate the stage of approach operation either armed (ARM) or activated (ACTV). Sequential button pushes if in ACTV would first result in approach ARM and then approach arm canceled. Subsequent button pushes will cycle between the armed state (if an approach is in the flight plan) and approach arm canceled. Approach ACTV cannot be selected manually. GPS APR and ARM are white. ACTV is green.
7. RMI NAV presentation switch - May be used to select data for presentation on the RMI; either NAV 2 data from the number two navigation receiver, or GPS data from the KLN 90B GPS.

C. PILOT'S DISPLAY

Left/right steering information is presented on the pilot's HSI as a function of the NAV/GPS switch position.

D. AUTOPILOT COUPLED OPERATION

The KLN 90B may be coupled to the autopilot by first selecting GPS on the NAV/GPS switch. Manual selection of the desired track on the pilot's HSI course pointer is required to provide course datum to the autopilot. (Frequent manual course pointer changes may be necessary, such as in the case of flying a DME arc.) The autopilot approach mode (APR) should be used when conducting a coupled GPS approach.

NOTE

Select HDG mode for DME arc intercepts. NAV or APR coupled DME arc intercepts can result in excessive overshoots (aggravated by high ground speeds and/or intercepts from inside the arc).

SECTION 4 - NORMAL PROCEDURES (CONT'D)**E. APPROACH MODE SEQUENCING AND RAIM PREDICTION****NOTE**

The special use airspace alert will automatically be disabled prior to flying an instrument approach to reduce the potential for message congestion.

1. Prior to arrival, select a STAR if appropriate from the APT 7 page. Select an approach and an initial approach fix (IAF) from the APT 8 page.

NOTES

- Using the right hand outer knob, select the ACT (Active Flight Plan Waypoints) pages. Pull the right hand inner knob out and scroll to the destination airport, then push the inner knob in and select the ACT 7 or ACT 8 page.
 - To delete or replace a SID, STAR or approach, select FPL 0 page. Place the cursor over the name of the procedure, press ENT to change it, or CLR then ENT to delete it.
2. En route, check for RAIM availability at the destination airport ETA on the STA 5 page.

NOTE

RAIM must be available at the FAF in order to fly an Instrument approach. Be prepared to terminate the approach upon loss of RAIM.

3. At 30 nm from the FAF:
 - a. Verify automatic annunciation of APR ARM.
 - b. Note automatic dbar scaling change from $\pm 5.0\text{nm}$ to $\pm 1.0\text{ nm}$ over the next 30 seconds.
 - c. Update the KLN 90B altimeter baro setting as required.
 - d. Internally the KLN 90B will transition from en route to terminal integrity monitoring.

SECTION 4 - NORMAL PROCEDURES (CONT'D)

4. Select Super NAV 5 page to fly the approach procedure.
 - a. If receiving radar vectors, or need to fly a procedure turn or holding pattern, fly in OBS until inbound to the FAF.

NOTE:

OBS navigation is TO-FROM (like a VOR) without waypoint sequencing.

- b. NoPT routes including DME arc's are flown in LEG. LEG is mandatory from the FAF to the MAP.

NOTE:

Select HDG mode for DME arc intercepts. NAV or APR coupled DME arc intercepts can result in excessive overshoots (aggravated by high ground speeds and/or intercepts from inside the arc).

WARNING:

Flying final outbound from an off airport vortac on an overlay approach; beware of the DME distance increasing on final approach, and the GPS distance-to-waypoint decreasing, and not matching the numbers on the approach plate!

5. At or before 2 nm from the FAF inbound:
 - a. Select the FAF as the active waypoint. if not accomplished already.
 - b. Select LEG operation.
6. Approaching the FAF inbound (within 2 nm.):
 - a. Verify APR ACTV.
 - b. Note automatic dbar scaling change from ± 1.0 nm to ± 0.3 nm over the 2 nm inbound to the FAF.
 - c. Internally the KLN 90B will transition from terminal to approach integrity monitoring.
7. Crossing the FAF and APR ACTV is not annunciated:
 - a. Do not descend.
 - b. Execute missed approach.

SECTION 4 - NORMAL PROCEDURES (CONT'D)

8. Missed Approach:
 - a. Climb
 - b. Navigate to the MAP (in APR ARM if APR ACTV is not available).

NOTE:

There is no automatic LEG sequencing at the MAP.

- c. After climbing in accordance with the published missed approach procedure, press [~~→~~], verify or change the desired holding fix and press ENT.

GENERAL NOTES

- The data base must be up to date for instrument approach operation.
- Only one approach can be in the flight plan at a time.
- If the destination airport is the active waypoint at the time of the instrument approach selection, the active waypoint will shift automatically to the chosen IAF.
- Checking RAIM prediction for your approach while en route using the STA 5 page is recommended. A self check occurs automatically within 2nm of the FAF. APR ACTV is inhibited without RAIM.
- Data cannot be altered, added to or deleted from the approach procedures contained in the data base. (DME arc intercepts may be relocated along the arc through the SUPER NAV 5 or the FPL 0 pages).
- Some approach waypoints do not appear on the approach plates (including in some instances the FAF)!

SECTION 4 - NORMAL PROCEDURES (CONT'D)

- Waypoint suffixes in the flight plan:
 - i - IAF
 - f - FAF
 - m - MAP
 - h - missed approach holding fix.

- The DME arc IAF (arc intercept waypoint) will be a) on your present position radial off the arc VOR when you load the IAF into the flight plan, or b) the beginning of the arc if currently on a radial beyond the arc limit. To adjust the arc intercept to be compatible with a current radar vector, bring up the arc IAF waypoint in the SUPER NAV 5 page scanning field or under the cursor on the FPL 0 page, press CLR, then ENT. Fly the arc in LEG. adjust the HSI or CDI course pointer with reference to the desired track value on the SUPER NAV5 page (it will flash to remind you). Left/right dbar information is relative to the arc. Displayed distance is not along the arc but direct to the active waypoint. If desired, select NAV 2 page for digital DME arc distance to and radial from the reference VOR. (The ARC radial is also displayed on the SUPERNAV5 page.)

- The DME arc IAF identifier may be unfamiliar. Example: D098G where 098 stands for the 098° radial off the referenced VOR, and G is the seventh letter in the alphabet indicating a 7 DME arc.

SECTION 4 - NORMAL PROCEDURES (CONT'D)

- APR ARM to APR ACTV is automatic provided:
 - a. You are in APR ARM (normally automatic).
 - b. You are in LEG mode!
 - c. The FAF is the active ; waypoint
 - d. Within 2 n.m. of the FAF.
 - e. Outside of the FAF.
 - f. Inbound to the FAF.
 - g. RAIM is available.
- Direct-To operation between the FAF and MAP cancels APR ACTV. Fly the missed approach in APR ARM.
- Flagged navigation inside the FAF may usually be restored (not guaranteed) by pressing the GPS APR button changing from ACTV to ARM. Fly the missed approach.
- The instrument approach using the KLN 90B may be essentially automatic starting 30 nm out (with a manual baro setting update) or it may require judicious selection of the OBS and LEG modes.
- APR ARM may be canceled at any time by pressing the GPS APR button. (A subsequent press will reselect it.)

SECTION 5 - PERFORMANCE

No Change.

SECTION 6 - WEIGHT AND BALANCE

Factory installed optional equipment is included in the licensed weight and balance data in Section 6 of the Basic Pilot's Operating Handbook.s

THIS PAGE INTENTIONALLY LEFT BLANK

**PILOT'S OPERATING HANDBOOK
AND
FAA APPROVED AIRPLANE FLIGHT MANUAL**

**SUPPLEMENT NO. 5
FOR
BENDIX/KING KX 155A
COMM/NAV SYSTEM**

This supplement must be attached to the Pilot's Operating Handbook and FAA Approved Airplane Flight Manual when the KX 155A Comm/Nav System is installed per the Piper Drawings. The information contained herein supplements or supersedes the Pilot's Operating Handbook and FAA Approved Airplane Flight Manual only in those areas listed herein. For limitations, procedures and performance information not contained in this supplement, consult the Pilot's Operating Handbook and FAA Approved Airplane Flight Manual.

FAA APPROVED:



PETER E. PECK
D.O.A. NO. SO-1
THE NEW PIPER AIRCRAFT, INC.
VERO BEACH, FLORIDA

DATE OF APPROVAL: June 20, 1998

SECTION 1 GENERAL

This supplement supplies information necessary for the operation of the airplane when the Bendix/King KX 155A Comm/Nav System is installed in accordance with FAA approved Piper data.

SECTION 2 LIMITATIONS

No change.

SECTION 3- EMERGENCY PROCEDURES

No change.

SECTION 4- NORMAL PROCEDURES

COMM TRANSCEIVER

- (a.) Rotate the volume (VOL) knob clockwise from the OFF position.
- (b.) Pull the VOL knob out and adjust for desired listening level.
- (c.) Push the VOL knob back in to actuate the automatic squelch.
- (d.) Select the desired operating frequency in the standby display by rotating the frequency select knobs either clockwise or counter-clockwise.
- (e.) Push the comm transfer button to transfer the frequency from the standby to the active display.

NAV RECEIVER

- (a.) The right portion of the display is allocated to NAV receiver information. The frequency channeling is similar to the Comm when operating in the frequency mode. The NAV increment/decrement knobs are located on the right hand side of the front panel.

SECTION 5- PERFORMANCE

No change.

SECTION 6- WEIGHT AND BALANCE

See Section 6 of the basic Pilots Operating Handbook.

SECTION 7 DESCRIPTION & OPERATION

GENERAL

All controls required to operate the KX 155A are located on the unit front panel. (See Figure 3-1.)

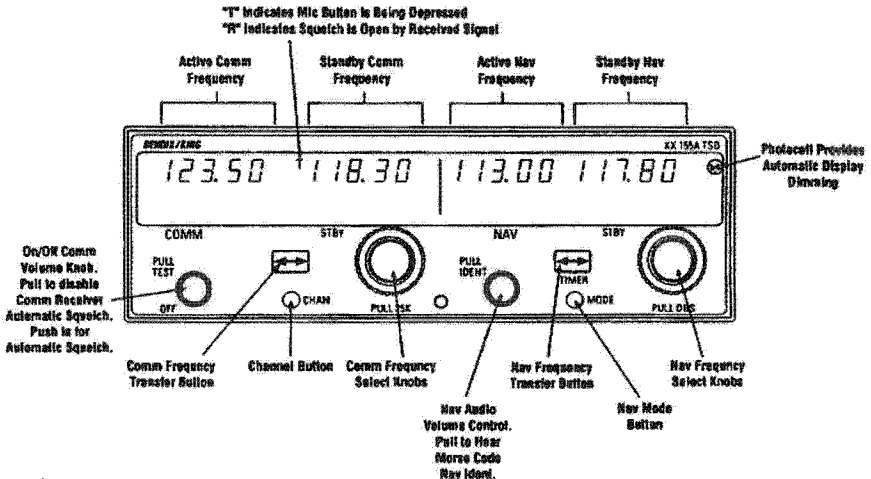

FIGURE 3-1
KX 155A CONTROL FUNCTIONS

COMM TRANSCEIVER

Rotate the VOL knob clockwise from the OFF position. Pull the VOL knob out and adjust for desired listening level. Push the VOL knob back in to actuate the automatic squelch.

The left portion of the digital display readout is allocated for COMM ACTIVE, and COMM STANDBY frequencies with a "T" between them to indicate TRANSMIT and an "R" to indicate RECEIVE modes of operation.

Select the desired operating frequency in the standby display by rotating the Frequency Select Knobs either clockwise or counter-clockwise. A clockwise rotation will increment the previous frequency while a counterclockwise rotation will decrement the previous frequency.

COMM TRANSCEIVER (CONT'D)

The outer knob will change the MHz portion of the standby display. At one band-edge (118 or 136 MHz) the following 1 MHz change will wrap around to the other band-edge. The inner knob will change the kHz portion of the standby display. It will change in steps of 50 kHz when the knob is pushed in, and 25 kHz when the knob is pulled out. For 8.33 kHz versions, channels are incremented in 25 kHz steps with the knob pushed in and 8.33 kHz with the knob pulled out. (Both 8.33 kHz and 25 kHz frequencies are channeled when the knob is pulled out). The frequency wrap around at the edge of the band is also utilized when incrementing or decrementing the kHz portion of the standby display.

To tune the radio to the desired operating frequency, the desired frequency must be entered into the standby display and then the transfer button must be pushed. This will trade the contents of the active and standby displays. The operating frequency can also be entered by accessing the ACTIVE ENTRY (direct tune) mode which is done by pushing and holding the COMM TRANSFER button for 2 or more seconds. In the direct tune mode, only the active part of the display is visible. The desired frequency can be directly entered into the display. Push the COMM TRANSFER button again to return to the active/standby display.

The transceiver is always tuned to the frequency appearing in the ACTIVE display. It is therefore possible to have two different frequencies stored in the ACTIVE and STANDBY displays and to change back and forth between them at the simple push of the transfer button.

During the transmit mode of operation, a "T" will appear between the ACTIVE and STANDBY displays. An "R" will appear between the ACTIVE and STANDBY displays if a detected signal is strong enough to open the squelch, signifying that the transceiver is in the receive mode of operation.

A non-volatile memory stores the comm ACTIVE and STANDBY frequencies on power down. When the unit is turned on again, the COMM ACTIVE and STANDBY windows will display the same ACTIVE and STANDBY frequencies that were displayed before power down.

The KX 155A also has provision to program 32 channels. Pressing the CHAN button for 2 or more seconds will cause the unit to enter the channel program mode. Upon entering the channel program mode, "PG" is displayed next to the channel number and the channel number will flash indicating that it can be programmed. The desired channel can be selected by turning the comm kHz knob. The channel frequency can be entered by pushing the COMM TRANSFER button which will cause the standby frequency to flash. The comm frequency knobs are then used to enter the desired frequency. If dashes (displayed when rotating the outer knob between 136 MHz and 118 MHz) are entered instead of a frequency, the corresponding channel is skipped in channel selection mode. Additional channels may be programmed by pressing the COMM TRANSFER and using the same procedure. To exit the program mode and save the channel information, momentarily push the CHAN button. This will cause the unit to return to the previous frequency entry mode. The unit will also exit the channel program mode if there is no button or knob activity for 20 seconds.

The channel selection mode can then be entered by momentarily pushing CHAN button. "CH" is displayed next to the last used channel number. The comm frequency knobs can be used to select the desired channel. The unit will automatically default to the previous mode if no channel is selected within 2 seconds after entering the channel selection mode.

The unit is placed in the transmit mode by depressing the MIC KEY button. The unit has a stuck microphone alert feature. If the microphone is keyed continuously for greater than 33 seconds, the transmitter stops transmitting and the active Comm frequency flashes to alert the pilot of the stuck microphone condition.

NAV RECEIVER

The right portion of the display is allocated to NAV receiver information. The frequency channeling is similar to the COMM when operating in the frequency mode (Figure 3-1). The NAV increment/decrement knobs are located on the right hand side of the front panel. The outer knob operates in 1 MHz steps and increments/decrements the STANDBY frequency display.

NAV RECEIVER (CONT'D)

The inner knob operates in 50 kHz steps. The NAV receiver's lower and upper frequency limits are 108.00 MHz and 117.95 MHz. Exceeding the upper limit of frequency band will automatically return to the lower limit and vice versa.

Depressing the NAV frequency transfer button for 2 seconds or more will cause the display to go in to the ACTIVE ENTRY mode. Only the ACTIVE frequency will be displayed and it can be directly changed by using the NAV inc/dec knobs. The display will return to the ACTIVE/STANDBY mode when the NAV frequency transfer button is pushed.

Depressing the mode button will cause the NAV display to go from the ACTIVE/STANDBY format to the ACTIVE/CDI (Course Deviation Indicator) format as shown below in Figure 3-2. In the CDI mode, the increment/decrement knob (pushed in) channels the ACTIVE frequency window and depressing the frequency transfer button will cause the ACTIVE frequency to be placed in blind storage and the STANDBY frequency (in blind storage) to be displayed in the ACTIVE window display. When the ACTIVE window is tuned to a VOR frequency, the standby frequency area is replaced by a three digit OBS (Omni Bearing Selector) display. The desired OBS course can be selected by pulling out the inner NAV frequency knob and turning it. This OBS display is independent of any OBS course selected on an external CDI or HSI. An "OBS" in the middle of the NAV display will flash while the inner NAV frequency knob is pulled out. The CDI is displayed on the line below the frequency/OBS. When the ACTIVE window is tuned to a localizer frequency, the standby frequency area is replaced by "LOC" Figure 3-3. Illustrations of the display are shown on the next page.

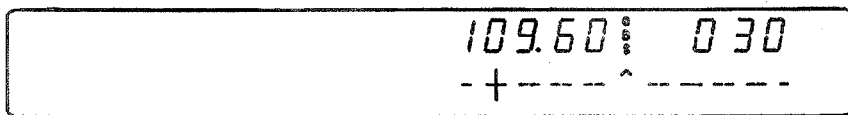

FIGURE 3-2
NAV DISPLAY; ACTIVE VOR FREQUENCY/CDI FORMAT



**FIGURE 3-3
NAV DISPLAY; ACTIVE LOCALIZER FREQUENCY/CDI FORMAT**

When the received signal is too weak to ensure accuracy the display will "flag". See Figure 3-4.



FIGURE 3-4 VOR FLAG DISPLAY

NAV RECEIVER (CONT'D)

Depressing the mode button will cause the NAV display to go from the ACTIVE/CDI format to the ACTIVE/BEARING format. In the BEARING mode, the increment/decrement knob channels the ACTIVE frequency window and depressing the frequency transfer button will cause the ACTIVE frequency to be placed in blind storage and the STANDBY frequency (in blind storage) to be displayed in the ACTIVE window display. In bearing mode of operation, the right hand window of NAV display shows the bearing TO the station. Figure 3-5 below illustrates the NAV side of the display in this mode:



FIGURE 3-5 VOR MODE; BEARING TO FUNCTION

When a too weak or invalid VOR signal is received the display flags as shown in Figure 3-6.



FIGURE 3-6 VOR MODE; ACTIVE/BEARING, FLAG DISPLAY

Another push of the mode button will cause the NAV display to go from the ACTIVE/BEARING format to the ACTIVE/RADIAL format as shown in Figure 3-7. In the RADIAL mode, the increment/decrement knob channels the ACTIVE frequency window and depressing the frequency transfer button will cause the ACTIVE frequency to be placed in blind storage and the STANDBY frequency (in blind storage) to be displayed in the ACTIVE window display. In radial mode of operation, the right hand window of NAV display shows the radial FROM the station. The picture below illustrates the NAV side of the display in this mode:



FIGURE 3-7 VOR MODE; RADIAL FROM FUNCTION

When a too weak or invalid VOR signal is received the display flags as shown



in Figure 3-8.

FIGURE 3-8 VOR MODE; ACTIVE/RADIAL, FLAG DISPLAY

NAV RECEIVER (CONT'D)

Another push of the mode button will cause the unit to go into the TIMER mode. See Figure 3-9. When the unit is turned on the elapsed timer begins counting upwards from zero. The timer can be stopped and reset to zero by pushing the NAV frequency transfer button for 2 seconds or more causing the ET on the display to flash. In this state the timer can be set as a countdown timer or the elapsed timer can be restarted. The countdown timer is set by using the NAV inc/dec knobs to set the desired time and then pushing the NAV frequency transfer button to start the timer. The outer knob selects minutes, the inner knob in the "in ~ position selects ten second intervals, and the inner knob in the ~out" position selects individual seconds. After the countdown timer reaches zero, the counter will begin to count upwards indefinitely while flashing for the first 15 seconds. The elapsed timer can also be reset to zero and started again after it has been stopped and reset to zero by pushing the NAV frequency transfer button.

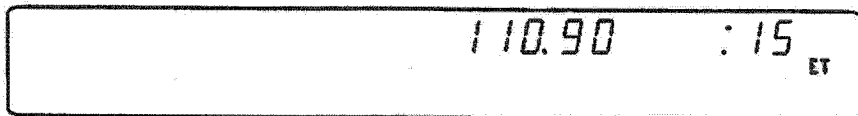

FIGURE 3-9 TIMER MODE

The NAV ACTIVE and STANDBY frequencies are stored in the memory on power down and return on power up.

When the smaller increment/decrement knob is pushed in, depressing the NAV TRANSFER button will interchange the ACTIVE and STANDBY frequencies. The NAV IDENT knob is active in the pulled out position so that both voice and ident can be heard. When this knob is pushed in, the ident tone is attenuated. The volume of voice/ident can be adjusted by turning this knob.

PILOT CONFIGURATION

This mode can be accessed by pressing and holding the Nav Mode Button for more than 2 seconds and then pressing the Nav Frequency Transfer Button for an additional 2 seconds, while continuing to hold the Nav Mode Button. When the Pilot Config Mode is entered the unit will show the "SWRV" mnemonic which is the unit software revision level. Adjustment pages can be accessed by MODE button presses.

The pilot may adjust two parameters in the pilot configuration, the display minimum brightness and sidetone volume level. See Table 3-1.

Minimum Brightness (BRIM) will have a range of 0 - 255. The dimmest is 0 and the brightest is 255.

Sidetone volume level is adjusted when SIDE is displayed. Values from 0 - 255 may be selected with 0 being least volume, 255 being the greatest.

Adjustment	Mnemonic	Min Level	Max Level
Software Revision Number	SWRV	--	--
Minimum Display Brightness	BRIM	0	255
Sidetone Level	SIDE	0	255

Table 3-1 Pilot Configuration

Subsequent presses of the MODE button sequences through SWRV, BRIM, SIDE, and then back to SWRV.

Momentarily pressing the Nav Transfer Button exits Pilot configuration mode. The Nav returns to its pre-Pilot Config state with the new brightness and sidetone levels stored in non-volatile memory.

THIS PAGE INTENTIONALLY LEFT BLANK

**PILOT'S OPERATING HANDBOOK
AND
FAA APPROVED AIRPLANE FLIGHT MANUAL**

**SUPPLEMENT NO. 6
FOR
GARMIN GNS 430 VHF COMMUNICATION
TRANSCEIVER/VOR/ILS RECEIVER/GPS RECEIVER
(Serial Numbers 4496031 and up)**

This supplement must be attached to the Pilot's Operating Handbook and FAA Approved Airplane Flight Manual when the Garmin GNS 430 VHF Communication Transceiver/VOR/ILS Receiver/Global Positioning System is installed per the Equipment List. The information contained herein supplements or supersedes the Pilot's Operating Handbook and FAA Approved Airplane Flight Manual only in those areas listed herein. For limitations, procedures and performance information not contained in this supplement, consult the Pilot's Operating Handbook and FAA Approved Airplane Flight Manual.

FAA APPROVED:



CHRISTINA L. MARSH
D.O.A. NO. SO-1
THE NEW PIPER AIRCRAFT, INC.
VERO BEACH, FLORIDA

DATE OF APPROVAL: NOVEMBER 30, 1999

SECTION 1 - GENERAL

The GNS 430 System is a fully integrated, panel mounted instrument, which contains a VHF Communications Transceiver, a VOR/ILS receiver, and a Global Positioning System (GPS) Navigation computer. The system consists of a GPS antenna, GPS receiver, VHF VOR/LOC/GS antenna, VOR/ILS receiver, VHF COMM antenna and a VHF Communications transceiver. The primary function of the VHF Communication portion of the equipment is to facilitate communication with Air Traffic Control. The primary function of the VOR/ILS Receiver portion of the equipment is to receive and demodulate VOR, Localizer, and Glide Slope signals. The primary function of the GPS portion of the system is to acquire signals from the GPS system satellites, recover orbital data, make range and Doppler measurements, and process this information in real-time to obtain the user's position, velocity, and time.

Provided the GARMIN GNS 430's GPS receiver is receiving adequate usable signals, it has been demonstrated capable of and has been shown to meet the accuracy specifications for:

VFR/IFR enroute, terminal, and non-precision instrument approach (GPS, Loran-C, VOR, VOR-DME, TACAN, NDB, NDB-DME, RNAV) operation within the U.S. National Airspace System in accordance with AC 20-138.

North Atlantic Minimum Navigation Performance Specification (MNPS) Airspace in accordance with AC 91-49 and AC 120-33.

Navigation is accomplished using the WGS-84 (NAD-83) coordinate reference datum. Navigation data is based upon use of only the Global Positioning System (GPS) operated by the United States of America.

SECTION 2 - LIMITATIONS

- A. The GARMIN GNS 430 Pilot's Guide, p/n 190-00140-00, Rev. A, dated October 1998, or later appropriate revision, must be immediately available to the flight crew whenever navigation is predicated on the use of the system.
- B. The GNS 430 must utilize the following or later FAA approved software versions:

Sub-System	Software Version
Main	2.00
GPS	2.00
COMM	2.00
VOR/LOC	2.00
G/S	2.00

The main software version is displayed on the GNS 430 self test page immediately after turn-on for 5 seconds. The remaining system software versions can be verified on the AUX group sub-page 2, "SOFTWARE/DATABASE VER".

- C. IFR enroute and terminal navigation predicated upon the GNS 430's GPS Receiver is prohibited unless the pilot verifies the currency of the data base or verifies each selected waypoint for accuracy by reference to current approved data.
- D. Instrument approach navigation predicated upon the GNS 430's GPS Receiver must be accomplished in accordance with approved instrument approach procedures that are retrieved from the GPS equipment data base. The GPS equipment data base must incorporate the current update cycle.
1. Instrument approaches utilizing the GPS receiver must be conducted in the approach mode and Receiver Autonomous Integrity Monitoring (RAIM) must be available at the Final Approach Fix.

SECTION 2 - LIMITATIONS (continued)

2. Accomplishment of ILS, LOC, LOC-BC, LDA, SDF, MLS or any other type of approach not approved for GPS overlay with the GNS 430's GPS receiver is not authorized.
 3. Use of the GNS 430 VOR/ILS receiver to fly approaches not approved for GPS require VOR/ILS navigation data to be present on the external indicator.
 4. When an alternate airport is required by the applicable operating rules, it must be served by an approach based on other than GPS or Loran-C navigation, the aircraft must have the operational equipment capable of using that navigation aid, and the required navigation aid must be operational.
 5. VNAV information may be utilized for advisory information only. Use of VNAV information for Instrument Approach Procedures does not guarantee Step-Down Fix altitude protection, or arrival at approach minimums in normal position to land.
- E. If not previously defined, the following default settings must be made in the "SETUP 1" menu of the GNS 430 prior to operation (refer to Pilot's Guide for procedure if necessary):
1. dis, spd..... $\frac{n}{m}$ k_t (sets navigation units to "nautical miles" and "knots")
 2. alt, vs..... f_t fpm (sets altitude units to "feet" and "feet per minute")
 3. map datum..WGS 84 (sets map datum to WGS-84, see not below)
 4. posn.....deg-min (sets navigation grid units to decimal minutes)

NOTE

In some areas outside the United States, datums other than WGS-84 or NAD-83 may be used. If the GNS 430 is authorized for use by the appropriate Airworthiness authority, the required geodetic datum must be set in the GNS 430 prior to its use for navigation.

SECTION 3 - EMERGENCY PROCEDURES**ABNORMAL PROCEDURES**

- A. If GARMIN GNS 430 navigation information is not available or invalid, utilize remaining operational navigation equipment as required.
- B. If “RAIM POSITION WARNING” message is displayed the system will flag and no longer provide GPS based navigational guidance. The crew should revert to the GNS 430 VOR/ILS receiver or an alternate means of navigation other than the GNS 430’s GPS receiver.
- C. If “RAIM IS NOT AVAILABLE” message is displayed in the enroute, terminal, or initial approach phase of flight, continue to navigate using the GPS equipment or revert to an alternate means of navigation other than the GNS 430’s GPS receiver appropriate to the route and phase of flight. When continuing to use GPS navigation, position must be verified every 15 minutes using the GNS 430’s VOR/ILS receiver or another IFR-approved navigation system.
- D. If “RAIM IS NOT AVAILABLE” message is displayed while on the final approach segment, GPS based navigation will continue for up to 5 minutes with approach CDI sensitivity (0.3 nautical mile). After 5 minutes the system will flag and no longer provide course guidance with approach sensitivity. Missed approach course guidance may still be available with 1 nautical mile CDI sensitivity by executing the missed approach.
- E. In an in-flight emergency, depressing and holding the Comm transfer button for 2 seconds will select the emergency frequency of 121.500 Mhz into the “Active” frequency window.

SECTION 4 - NORMAL PROCEDURES

WARNING

Familiarity with the enroute operation of the GNS 430 does not constitute proficiency in approach operations. Do not attempt approach operations in IMC prior to attaining proficiency in the use of the GNS 430 approach feature.

A. DETAILED OPERATING PROCEDURES

Normal operating procedures are described in the GARMIN GNS 430 Pilot's Guide, p/n 190-00140-00, Rev. A, dated October 1998, or later appropriate revision.

B. PILOT'S DISPLAY

The GNS 430 System data will appear on the Pilot's HSI. The source of data is either GPS or VLOC as annunciated on the display above the CDI key.

C. AUTOPILOT/FLIGHT DIRECTOR OPERATION

Coupling of the GNS 430 System steering information to the autopilot/flight director can be accomplished by engaging the autopilot/flight director in the NAV or APR mode.

When the autopilot/flight director system is using course information supplied by the GNS 430 System and the course pointer is not automatically driven to the desired track, the course pointer on the HSI must be manually set to the desired track (DTK) indicated by the GNS 430. For detailed autopilot/flight director operational instructions, refer to the FAA Approved Flight Manual Supplement for the autopilot/flight director.

SECTION 4 - NORMAL PROCEDURES (continued)**D. AUTOMATIC LOCALIZER COURSE CAPTURE**

By default, the GNS 430 automatic localizer course capture feature is enabled. This feature provides a method for system navigation data present on the external indicators to be switched automatically from GPS guidance to localizer / glide slope guidance at the point of course intercept on a localizer at which GPS derived course deviation equals localizer derived course deviation. If an offset from the final approach course is being flown, it is possible that the automatic switch from GPS course guidance to localizer / glide slope course guidance will not occur. It is the pilot's responsibility to ensure correct system navigation data is present on the external indicator before continuing a localizer based approach beyond the final approach fix.

SECTION 5 - PERFORMANCE

No change.

SECTION 6 - WEIGHT AND BALANCE

Factory installed optional equipment is included in the licensed weight and balance data in Section 6 of the basic Pilot's Operating Handbook.

SECTION 7 - DESCRIPTION AND OPERATION

See GNS 430 Pilot's Guide for a complete description of the GNS 430 system.

THIS PAGE INTENTIONALLY LEFT BLANK

**PILOT'S OPERATING HANDBOOK
AND
FAA APPROVED AIRPLANE FLIGHT MANUAL**

**SUPPLEMENT NO. 7
FOR
S-TEC SYSTEM 55 TWO AXIS
AUTOMATIC FLIGHT GUIDANCE SYSTEM
WITH TRIM MONITOR**

(Serial numbers 4496031 and up)

The FAA approved operational supplement for the S-TEC System 55 Autopilot, installed in accordance with STC SA09131AC-D, is required for operation of this system. S-TEC will be responsible to supply and revise the operational supplement. It is permitted to include the S-TEC supplement in this location of the Pilot's Operating Handbook unless otherwise stated by S-TEC. The information contained in the S-TEC supplement may supersede or supplement the information in the basic Pilot's Operating Handbook and FAA Approved Airplane Flight Manual with respect to the operation of the S-TEC System 55 Autopilot. For limitations, procedures and performance information not contained in the S-TEC supplement, consult the basic Pilot's Operating Handbook and FAA Approved Airplane Flight Manual.

THIS PAGE INTENTIONALLY LEFT BLANK

**PILOT'S OPERATING HANDBOOK
AND
FAA APPROVED AIRPLANE FLIGHT MANUAL**

**SUPPLEMENT NO. 8
FOR
S-TEC MANUAL ELECTRIC TRIM SYSTEM
WITH TRIM MONITOR
(Serial numbers 4496012 and up)**

The FAA approved operational supplement for the S-TEC Manual Electric Trim System, installed in accordance with STC SA09139AC-D, is required for operation of this system. S-TEC will be responsible to supply and revise the operational supplement. It is permitted to include the S-TEC supplement in this location of the Pilot's Operating Handbook unless otherwise stated by S-TEC. The information contained in the S-TEC supplement may supersede or supplement the information in the basic Pilot's Operating Handbook and FAA Approved Airplane Flight Manual with respect to the operation of the S-TEC Manual Electric Trim System. For limitations, procedures and performance information not contained in the S-TEC supplement, consult the basic Pilot's Operating Handbook and FAA Approved Airplane Flight Manual.

THIS PAGE INTENTIONALLY LEFT BLANK

**PILOT'S OPERATING HANDBOOK
AND
FAA APPROVED AIRPLANE FLIGHT MANUAL

SUPPLEMENT NO. 9
FOR
AIRLINE TRANSPORT PROFESSIONALS SEMINOLE TRAINERS**

This supplement must be attached to the Pilot's Operating Handbook and FAA Approved Airplane Flight Manual when the optional Battery Master Hourmeter is installed per the Equipment List. The information contained herein supplements or supersedes the information in the basic Pilot's Operating Handbook and FAA Approved Airplane Flight Manual only in those areas listed herein. For limitations, procedures and performance information not contained in this supplement, consult the basic Pilot's Operating Handbook and FAA Approved Airplane Flight Manual.

FAA APPROVED: *Christina L. Marsh*
CHRISTINA L. MARSH
D.O.A. NO. SO-1
THE NEW PIPER AIRCRAFT, INC.
VERO BEACH, FLORIDA

SECTION 1 - GENERAL

This supplement supplies information necessary for the operation of the airplane when the optional Battery Master Hourmeter is installed in accordance with FAA approved Piper data.

SECTION 2 - LIMITATIONS

No change.

SECTION 3 - EMERGENCY PROCEDURES

No change.

SECTION 4 - NORMAL PROCEDURES

No change.

SECTION 5 - PERFORMANCE

No change.

SECTION 6 - WEIGHT AND BALANCE

See Section 6 of the basic Pilot's Operating Handbook.

SECTION 7 - DESCRIPTION AND OPERATION

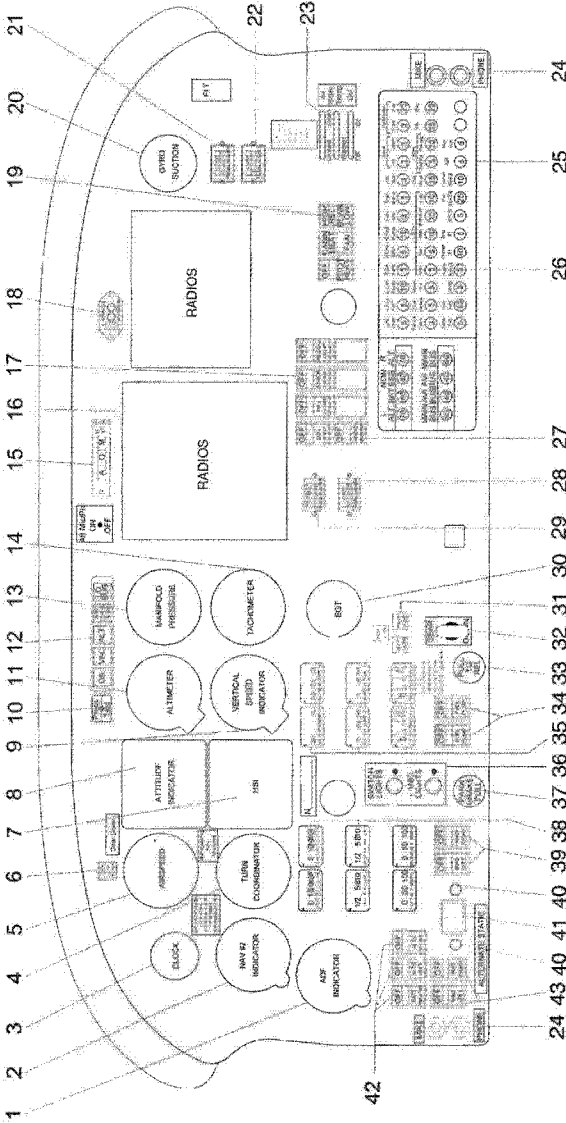

INSTRUMENT PANEL

Figure 7-1

1. ADF INDICATOR
2. NAV #2 INDICATOR
3. CLOCK
4. TURN COORDINATOR
5. AIRSPEED INDICATOR
6. GEAR UNSAFE WARNING LIGHT
7. HORIZONTAL SITUATION INDICATOR
8. ATTITUDE INDICATOR
9. VERTICAL SPEED INDICATOR
10. ANNUNCIATOR TEST SWITCH
11. ALTIMETER
12. ANNUNCIATOR DISPLAY
13. DUAL MANIFOLD PRESSURE
14. DUAL TACHOMETER
15. MARKER BEACON
16. AVIONICS
17. EXTERIOR LIGHT SWITCHES
18. GYRO SLAVING CONTROL
19. ENVIRONMENTAL CONTROL SWITCHES
20. GYRO SUCTION
21. ENGINE HOURMETER
22. FLIGHT HOURMETER
23. CABIN TEMP CONTROLS
24. MIC/PHONE JACKS
25. CIRCUIT BREAKER PANEL
26. PITOT HEAT SWITCH
27. RADIO MASTER SWITCH
28. HEATER HOURMETER
29. BATTERY MASTER HOURMETER
30. EXHAUST GAS TEMPERATURE
31. GEAR POSITION INDICATOR
32. LANDING GEAR SELECTOR
33. EMERGENCY GEAR EXTENSION HANDLE
34. FUEL PUMP SWITCHES
35. INSTRUMENT CLUSTER
 - L & R CYL HEAD TEMPERATURE
 - L & R OIL TEMPERATURE
 - L & R OIL PRESSURE
36. INTERIOR LIGHTS
37. PARKING BRAKE HANDLE
38. INSTRUMENT CLUSTER
 - L & R FUEL QUANTITY
 - L & R FUEL PRESSURE
 - L & R ALTERNATOR AMMETERS
39. RIGHT ENGINE MAGNETO SWITCHES
40. PRIMER SWITCHES
41. L & R START SWITCHES
42. BATTERY & ALTERNATOR SWITCHES
43. LEFT ENGINE MAGNETO SWITCHES

INSTRUMENT PANEL

Figure 7-1 (continued)

**PILOT'S OPERATING HANDBOOK
AND
FAA APPROVED AIRPLANE FLIGHT MANUAL

SUPPLEMENT NO. 10
FOR
GARMIN GTX 327 TRANSPONDER**

This supplement must be attached to the Pilot's Operating Handbook and FAA Approved Airplane Flight Manual when the Garmin GTX 327 Transponder is installed per the Equipment List. The information contained herein supplements or supersedes the Pilot's Operating Handbook and FAA Approved Airplane Flight Manual only in those areas listed herein. For limitations, procedures and performance information not contained in this supplement, consult the Pilot's Operating Handbook and FAA Approved Airplane Flight Manual.

FAA APPROVED: Christina L. Marsh
CHRISTINA L. MARSH
D.O.A. NO. SO- 1
THE NEW PIPER AIRCRAFT, INC.
VERO BEACH, FLORIDA

DATE OF APPROVAL: January 12, 2001

SECTION 1 - GENERAL

This supplement supplies information necessary for the operation of the airplane when the Garmin GTX 327 Transponder is installed in accordance with FAA approved Piper data.

SECTION 2 - LIMITATIONS

No change.

SECTION 3 - EMERGENCY PROCEDURES

To transmit an emergency signal:

- Mode Selection Key - ALT
- Code Selection - SELECT 7700

To transmit a signal representing loss of all communications:

- Mode Selection Key - ALT
- Code Selection - SELECT 7600

SECTION 4 - NORMAL PROCEDURES

BEFORE TAKEOFF:

- To transmit Mode C (Altitude Reporting) code in flight:
- Mode Selection Key - ALT
- Code Selector Keys - SELECT assigned code.

To transmit Mode A (Aircraft Identification) code in flight:

- Mode Selector Key - ON
- Code Selector Keys - SELECT assigned code.

NOTE

During normal operation with the ON mode selected, the reply indicator "R" flashes, indicating transponder replies to interrogations.

NOTE

Mode A reply codes are transmitted in ALT also; however, Mode C codes only are suppressed when the Function Selector ON key is selected.

SECTION 5 - PERFORMANCE

No change.

SECTION 6 - WEIGHT AND BALANCE

Factory installed optional equipment is included in the licensed weight and balance data in section 6 of the Airplane Flight Manual.

SECTION 7 - DESCRIPTION AND OPERATION



The GTX 327 transponder is powered on by pressing the **STBY**, **ALT** or **ON** keys, or by a remote avionics master switch (if applicable). After power on, a start-up page will be displayed while the unit performs a self test.

Mode Selection Keys

OFF - Powers off the GTX 327.

STBY - Powers on the transponder in standby mode.

At power on the last active identification code will be selected. When in standby mode, the transponder will not reply to any interrogations.

ON - Powers on the transponder in Mode A. At power on the last active identification code will be selected. In this mode, the transponder replies to interrogations, as indicated by the Reply Symbol . Replies do not include altitude information.

ALT - Powers on the transponder in Mode A and Mode C. At power on the last active identification code will be selected. In ALT mode, the transponder replies to identification and altitude interrogations, as indicated by the Reply Symbol . Replies to altitude interrogations include the standard pressure altitude received from an external altitude source, which is not adjusted for barometric pressure. The ALT mode may be used in aircraft not equipped with the optional altitude encoder; however, the reply signal will not include altitude information.

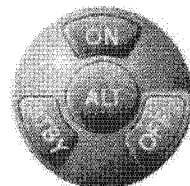

GTX 327 Configuration Mode

The GTX 327's configuration, which is normally done at time of installation, influences many of the unit's functions described in this manual. If you wish to view or change any of the GTX 327 configuration parameters, you may access the GTX 327 Configuration Mode. Use caution when changing configuration. When in doubt, contact your authorized GARMIN Aviation Service Center. The Configuration Mode should not be used while the aircraft is airborne.

SECTION 7 - DESCRIPTION AND OPERATION (continued)

GTX 327 Configuration Mode (continued)

To use the GTX 327 Configuration Mode:

1. Press and hold the **FUNC** key while powering on the unit using the **STBY**, **ON**, or **ALT** key (or using an avionics master switch).
2. Press the **FUNC** key to sequence through the configuration pages.
3. Use the **CRSR** key to highlight selectable fields on each page.
4. When a field is highlighted, enter numeric data using the **0 - 9** keys, and select items from a list using the **8** or **9** keys.
5. Press the **CRSR** key to confirm list selections.

Code Selection



Code selection is done with eight keys (**0 - 7**) that provide 4,096 active identification codes. Pushing one of these keys begins the code selection sequence. The new code will not be activated until the fourth digit is entered. Pressing the **CLR** key will move the cursor back to the previous digit. Pressing the **CLR** key when the cursor is on the first digit of the code, or pressing the **CRSR** key during code entry, will remove the cursor and cancel data entry, restoring the previous code. The numbers 8 and 9 are not used for code entry, only for entering a Count Down time, and in the Configuration Mode.



SECTION 7 - DESCRIPTION AND OPERATION (continued)

Code Selection (continued)

Important Codes:

- 1200** - The VFR code for any altitude in the US (Refer to ICAO standards elsewhere)
- 7000** - The VFR code commonly used in Europe (Refer to ICAO standards)
- 7500** - Hijack code (Aircraft is subject to unlawful interference)
- 7600** - Loss of communications
- 7700** - Emergency
- 7777** - Military interceptor operations (Never squawk this code)
- 0000** - Military use (Not enterable)

Care should be taken not to select the code 7500 and all codes in the 7600 - 7777 range, which trigger special indicators in automated facilities. Only the code 7500 will be decoded as the hijack code. An aircraft's transponder code (when available) is utilized to enhance the tracking capabilities of the ATC facility, therefore care should be taken when making routine code changes.

Keys for Other GTX 327 Functions



IDENT - Pressing the IDENT key activates the Special Position Identification (SPI) Pulse for 18 seconds, identifying your transponder return from others on the air traffic controller's screen. The word "IDENT" will appear in the upper left corner of the display while the IDENT mode is active.



VFR - Sets the transponder code to the pre-programmed VFR code selected in Configuration Mode (this is set to 1200 at the factory). Pressing the VFR key again will restore the previous identification code.





FUNC - Changes the page shown on the right side of the display. Displayed data includes Pressure Altitude, Flight Time, Count Up timer, Count Down timer, and may include Contrast and Display Brightness, depending on configuration (as shown in the screens below):

SECTION 7 - DESCRIPTION AND OPERATION (continued)

Keys for Other GTX 327 Functions (continued)

 **PRESSURE ALT:** Displays the altitude data supplied to the GTX 327 in feet, hundreds of feet (i.e., flight level), or meters, depending on configuration.

 **FLIGHT TIME:** Displays the Flight Time, which is controlled by the **START/STOP** key or by a squat switch as configured during installation. With squat switch control, the timer begins when lift off is sensed and pauses when landing is sensed.

 **COUNT UP TIMER:** Controlled by **START/STOP** and **CLR** keys.

 **COUNT DOWN TIMER:** Controlled by **START/STOP**, **CLR**, and **CRSR** keys. The initial Count Down time is entered with the **0 - 9** keys.

 **CONTRAST:** This page is only displayed if manual contrast mode is selected in Configuration Mode. Contrast is controlled by the **8** and **9** keys.

 **DISPLAY:** This page is only displayed if manual backlighting mode is selected in Configuration Mode. Backlighting is controlled by the **8** and **9** keys.



START/STOP - Starts and stops the Count Up and Count Down timers.



CRSR - Initiates entry of the starting time for the Count Down timer and cancels transponder code entry.



CLR - Resets the Count Up and Count Down timers and cancels the previous keypress during code selection.



8 - Reduces Contrast and Display Brightness when the respective pages are displayed. Also enters the number 8 into the Count Down timer.



9 - Increases Contrast and Display Brightness when the respective pages are displayed. Also enters the number 9 into the Count Down timer.

SECTION 7 - DESCRIPTION AND OPERATION (continued)

Altitude Trend Indicator

When the "PRESSURE ALT" page is displayed, an arrow may be displayed to the right of the altitude, indicating that the altitude is increasing or decreasing. One of two sizes of arrows may be displayed depending on the rate of climb/descent. The sensitivity of these arrows is set using the GTX Configuration Mode.

Timer Operation

To operate the Flight Timer:

1. Press the FUNC key until "FLIGHT TIME" is displayed.
2. If the GTX 327 is configured as having a squat switch installed, the timer will begin counting automatically when the squat switch senses that the aircraft has become airborne.
3. If desired, you may press **START/STOP** to pause or restart the timer.
4. Press **CLR** to reset the timer to zero.
5. If the GTX 327 is configured as having a squat switch installed, the timer will pause automatically when the squat switch senses that the aircraft has touched down.

To operate the Count Up timer:

1. Press the FUNC key until "COUNT UP" is displayed.
2. If necessary, press **CLR** to reset the Count Up timer to zero.
3. Press **START/STOP** to count up.
4. Press **START/STOP** again to pause the timer.
5. Press **CLR** to reset the timer to zero.

To operate the Count Down timer:

1. Press the FUNC key until "COUNT DOWN" is displayed.
2. Press **CRSR** and use the **0 - 9** keys to set the initial time. All digits must be entered (use the 0 key to enter leading zeros).
3. Press **START/STOP** to count down.
4. Press **START/STOP** again to pause the timer.
5. When the Count Down timer expires, the words "COUNT DOWN" are replaced with "EXPIRED", and the time begins counting up and flashing.
6. Press **CLR** to reset the timer to the initial time value.

SECTION 7 - DESCRIPTION AND OPERATION (continued)**Automatic ALT/STBY Mode Switching**

If the GTX 327 is configured for automatic standby switching, the mode will automatically change to ALT when a squat switch senses that the aircraft has become airborne. Also, the mode will change to STBY automatically when a squat switch senses that the aircraft has touched down. Additionally, a delay time can be set in the Configuration Mode, causing the GTX 327 to wait a specified length of time after landing before automatically changing to STBY mode.

THIS PAGE INTENTIONALLY LEFT BLANK

**PILOT'S OPERATING HANDBOOK
AND
FAA APPROVED AIRPLANE FLIGHT MANUAL**

**SUPPLEMENT NO. 11
FOR
S-TEC SYSTEM 55X TWO AXIS
AUTOMATIC FLIGHT GUIDANCE SYSTEM**

The FAA approved operational supplement for the S-TEC System 55X Autopilot, installed in accordance with STC SA09131AC-D, is required for operation of this system. S-TEC will be responsible to supply and revise the operational supplement. It is permitted to include the S-TEC supplement in this location of the Pilot's Operating Handbook unless otherwise stated by S-TEC. The information contained in the S-TEC supplement may supersede or supplement the information in the basic Pilot's Operating Handbook and FAA Approved Airplane Flight Manual with respect to the operation of the S-TEC System 55X Autopilot. For limitations, procedures and performance information not contained in the S-TEC supplement, consult the basic Pilot's Operating Handbook and FAA Approved Airplane Flight Manual.

THIS PAGE INTENTIONALLY LEFT BLANK

**PILOT'S OPERATING HANDBOOK
AND
FAA APPROVED AIRPLANE FLIGHT MANUAL**

**SUPPLEMENT NO. 12
FOR
S-TEC ADF-650A SYSTEM**

This supplement must be attached to the Pilot's Operating Handbook and FAA Approved Airplane Flight Manual when the S-TEC ADF-650A System is installed per the Equipment List. The information contained herein supplements or supersedes the Pilot's Operating Handbook and FAA Approved Airplane Flight Manual only in those areas listed herein. For limitations, procedures and performance information not contained in this supplement, consult the Pilot's Operating Handbook and FAA Approved Airplane Flight Manual.

FAA APPROVED: Christina L. Marsh
CHRISTINA L. MARSH
D.O.A. NO. SO- 1
THE NEW PIPER AIRCRAFT, INC.
VERO BEACH, FLORIDA

DATE OF APPROVAL: January 12, 2001

SECTION 1 - GENERAL

This supplement supplies information necessary for the operation of the airplane when the S-TEC ADF-650A System is installed in accordance with FAA approved Piper data.

SECTION 2 - LIMITATIONS

No change.

SECTION 3 - EMERGENCY PROCEDURES

No change.

SECTION 4 - NORMAL PROCEDURES

To operate as an Automatic Direction Finder:

- OFF/VOL Control - ON
- Frequency Selector Knobs - SELECT desired frequency.
- ADF SPEAKER/PHONE Selector Switch (on audio control panel) - SELECT as desired.
- OFF/VOL Control - SET to desired volume level.
- ADF Mode Control - Select ADF mode and note relative bearing on display.

ADF Test (Pre-flight or In-flight):

- ADF Mode Control - Select ADF mode and note relative bearing on display.
- Press the TEST button and note the pointer moves to 90° from its prior position. Excessive pointer sluggishness, wavering or reversals indicate a signal that is too weak or a system malfunction.

To Operate BFO:

- OFF/VOL Control - ON
- Frequency Selector Knobs - SELECT desired frequency.
- ADF SPEAKER/PHONE Selector Switch (on audio control panel) - SELECT as desired.
- ADF Mode Control - Select BFO mode.
- OFF/VOL Control - Set to desired volume level.

SECTION 5 - PERFORMANCE

No change.

SECTION 6 - WEIGHT AND BALANCE

Factory installed optional equipment is included in the licensed weight and balance data in Section 6 of the Pilot's Operating Handbook and Airplane Flight Manual.

SECTION 7 - DESCRIPTION AND OPERATION

The S-TEC ADF-650A System operates over a frequency range of 200 through 1799 kHz in 1-kHz increments. Three operating modes are included as part of the ADF-650 System.

- BFO
- ANT
- ADF

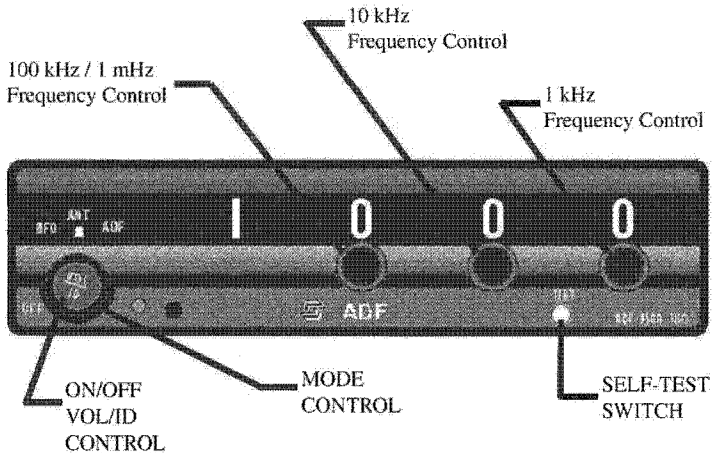

ADF-650A Receiver, Controls, and Indicators
Figure 1

BFO Mode

The BFO (beat frequency oscillator) and ADF (automatic direction finding) modes are navigation modes that result in pointing operation when in-range station is selected. The ADF mode is used with conventional nondirectional beacons and AM broadcast stations. The BFO mode is used to aurally identify stations that employ keyed cw rather than amplitude modulation techniques.

NOTE

CW signals (Morse Code) are unmodulated and no audio will be heard without use of BFO. This type of signal is not used in the United States air navigation. It is used in some foreign countries and marine beacons.

SECTION 7 - DESCRIPTION AND OPERATION (continued)**ANT (Antenna) Mode**

The ANT (antenna) mode cannot be used for navigation; this mode enhances audio reception clarity and is normally used for station identification.

ADF Mode

Automatic Direction Finder (ADF) mode is used for navigation. This mode activates the bearing pointer. The bearing pointer will point in the direction of the station relative to the aircraft heading.

Frequency Selector Controls

Three controls are used to select the system operating frequency. The right hand control selects 1 - kHz increments, the center control 10 - kHz increments, and the left hand control 100 - kHz increments.

Self Test Switch

Pressing and holding the spring loaded self test switch while in the ADF mode will cause the bearing pointer to rotate 90 degrees from its prior position if the ADF-650 system is operating properly. When the test switch is released, the bearing pointer should promptly return to its starting point. At this time, normal operation is restored.

ON/OFF/VOL/ID Control

This control performs three independent functions. In full ccw position, no power is applied to the system; rotating the control cw applies power and continued rotation increases volume. Pulling the knob out enhances the Morse code station identifier when background noise is present; push the knob to hear voice transmissions. A good operating practice is to pull the knob out for station identification purposes and then push it back in after positive identification has been made.

THIS PAGE INTENTIONALLY LEFT BLANK

PILOT'S OPERATING HANDBOOK
AND
FAA APPROVED AIRPLANE FLIGHT MANUAL

SUPPLEMENT NO. 13
FOR
GARMIN GMA 340 AUDIO PANEL

This supplement must be attached to the Pilot's Operating Handbook and FAA Approved Airplane Flight Manual when the Garmin GMA 340 is installed per the Equipment List. The information contained herein supplements or supersedes the information in the basic Pilot's Operating Handbook and FAA Approved Airplane Flight Manual only in those areas listed herein. For limitations, procedures, and performance information not contained in this supplement, consult the basic Pilot's Operating Handbook and FAA Approved Airplane Flight Manual.

FAA APPROVED



CHRISTINA L. MARSH
D.O.A. NO. SO-1
THE NEW PIPER AIRCRAFT, INC.
VERO BEACH, FLORIDA

DATE OF APPROVAL January 12, 2001

SECTION 1 - GENERAL

This supplement supplies information necessary for the operation of the airplane when the Garmin GMA 340 audio panel is installed in accordance with FAA approved Piper data.

SECTION 2 - LIMITATIONS

No change.

SECTION 3 - EMERGENCY PROCEDURES

No change.

SECTION 4 - NORMAL PROCEDURES

AUDIO CONTROL SYSTEM OPERATION:

- Select the desired transmitter audio selector button (COM1, COM2, OR COM3) and verify that the buttons LED is illuminated.
- INTERCOM VOL Control (ICS) - Adjust to desired listening level.
- INTERCOM VOX (voice) Sensitivity Control - ROTATE CONTROL knob clockwise to the middle range and then adjust as required for desired voice activation or hot mic intercom.
- If desired, select the speaker function button. Selecting this button allows radio transmissions to be received over the cabin speaker.

NOTE

Audio level is controlled by the selected NAV radio volume control.

MARKER BEACON RECEIVER OPERATION:

- TEST Button - PRESS to verify all marker lights are operational.
- SENS Button - SELECT HI for airway flying for LO for ILS/LOC approaches.

SECTION 5 - PERFORMANCE

No change.

SECTION 6 - WEIGHT AND BALANCE

Factory installed optional equipment is included in the licensed weight and balance data in section 6 of the Airplane Flight Manual.

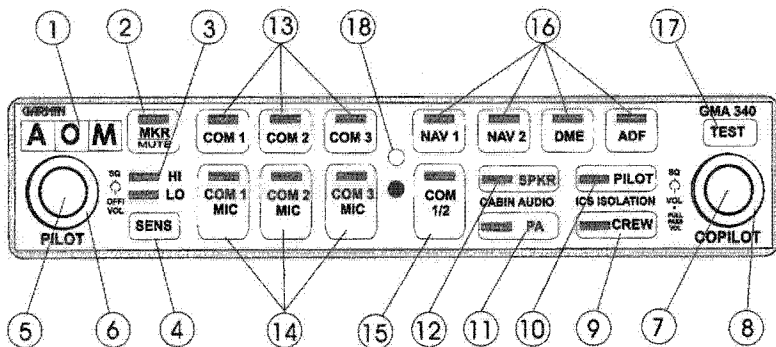
SECTION 7 - DESCRIPTION AND OPERATION

1. Marker Beacon Lamps
2. Marker Beacon Receiver Audio Select/Mute Button
3. Marker Beacon Receiver Sensitivity Selection Indicator LED
4. Marker Beacon Receiver Sensitivity Selection Button
5. Unit On/Off, Pilot Intercom System (ICS) Volume
6. Pilot ICS Voice Activated (VOX) Intercom Squelch Level
7. Copilot and Passenger ICS Volume Control (Pull out for Passenger Volume)
8. Copilot/Passenger VOX Intercom Squelch Level
9. Crew Isolation Intercom Mode Button
10. Pilot Isolation Intercom Mode Button
11. Passenger Address (PA) Function Button
12. Speaker Function Button
13. Transceiver Audio Selector Buttons (COM1, COM2, COM3)
14. Transmitter (Audio/Mic) Selection Buttons
15. Split COM Button
16. Aircraft Radio Audio Selection Buttons (NAV1, NAV2, DME, ADF)
17. Annunciator Test Button
18. Photocell - Automatic Annunciator Dimming

SECTION 7 - DESCRIPTION AND OPERATION (continued)

ON/OFF, Pilot Intercom System (ICS) Volume Control

The GMA 340 is powered OFF when the left small knob (5) is rotated fully CCW into the detent. To turn the unit ON, rotate the knob clockwise past the click. The knob then functions as the pilot ICS volume control. A fail safe circuit connects the pilot's headset and microphone directly to COM1 in case power is interrupted or the unit is turned OFF.

Transceivers

Selection of either COM1, COM2, or COM3 for both MIC and audio source is accomplished by pressing either COM1, MIC, COM2 MIC, COM3 MIC (14). The activeCOM audio is always heard on the headphones.

Additionally, each audio source can be selected independently by pressing COM1, COM2, or COM3 (13). When selected this way, they remain active as audio sources regardless of which transceiver has been selected for microphone use.

When a microphone is keyed, the active transceiver's MIC button LED blinks approximately one per second to indicate that the radio is transmitting.

NOTE

Audio level is controlled by the selected COM radio volume controls.

Split COM

Pressing the COM 1/2 button (15) activates the split COM function. When this mode is active, COM1 is dedicated solely to the pilot for MIC/Audio while COM2 is dedicated to the copilot for MIC/Audio. The pilot and copilot can simultaneously transmit in this mode over separate radios. Both pilots can still listen to COM3, NAV1, NAV2, DME, ADF, and MRK as selected. The split COM mode is cancelled by pressing the COM 1/2 button a second time.

When in the split COM mode the copilot may make PA announcements while the pilot continues using COM1 independently. When the PA button is pressed after the split com mode is activated the copilot's mic is output over the cabin speaker when keyed. A second press of the PA button returns the copilot to normal split COM operation.

SECTION 7 - DESCRIPTION AND OPERATION (continued)**Aircraft Radios and Navigation**

Pressing NAV1, NAV2, DME, ADF (16) or MRK (2) selects each audio source. A second button press deselects the audio.

Speaker Output

Pressing the SPKR button (12) selects the aircraft radios over the cabin speaker. The speaker output is muted when a COM microphone is keyed.

PA Function

The PA mode is activated by pressing the PA button (11). Then, when either the pilot's or copilot's microphone is keyed, the corresponding mic audio is heard over the cabin speaker. If the SKR button is also active, then any selected speaker audio is muted while the microphone is keyed. The SPKR button does not have to be previously active in order to use the PA function.

Intercom System (ICS)

Intercom volume and squelch (VOX) are adjusted using the following front panel knobs:

- **Left Small Knob** - Unit ON/OFF power control and pilot's ICS volume. Full CCW detent position is OFF.
- **Left Large Knob** - Pilot ICS mic VOX squelch level. CW rotation increases the amount of mic audio (VOX level) required to break squelch. Full CCW is the "HOT MIC" position (no squelch).
- **Right Small Knob** - IN position: Copilot ICS volume. OUT position: Passenger ICS volume.
- **Right Large Knob** - Copilot and passenger mic VOX squelch level. CW rotation increases the amount of mic audio (VOX level) required to break squelch. Full CCW is the "HOT MIC" position.
- **PILOT Mode** - This mode isolates the pilot from everyone else and dedicates the aircraft radios to the pilot exclusively. The copilot and passengers share communications between themselves but cannot communicate with the pilot or hear the aircraft radios.
- **CREW Mode** - This mode places the pilot and copilot on a common ICS communication channel with the aircraft radios. The passengers are on their own intercom channel and can communicate with each other, but cannot communicate with the crew or hear the aircraft radios.

SECTION 7 - DESCRIPTION AND OPERATION (continued)

Marker Beacon Receiver

The GMA 340's marker beacon receiver controls are located on the left side of the front panel (1 - 4). The SENS button selects either high or low sensitivity as indicated by the HI or LO LED being lit. Low sensitivity is used on ILS approaches while high sensitivity allows operation over airway markers or to get an earlier indication of nearing the outer marker during an approach.

The marker audio is initially selected by pressing the MKR/Mute button (2). If no beacon signal is received, then a second button press will deselect the marker audio. This operation is similar to selecting any other audio source on the GMA 340. However, if the second button press occurs while a marker beacon signal is received, then the marker audio is muted but not deselected. The button's LED will remain lit to indicate that the source is still selected. When the current marker signal is no longer received, the audio is automatically un-muted. While in the muted state, pressing the MKR/Mute button deselects the marker audio. The button's LED will extinguish to indicate that the marker audio is no longer selected.

**PILOT'S OPERATING HANDBOOK
AND
FAA APPROVED AIRPLANE FLIGHT MANUAL**

**SUPPLEMENT NO. 14
FOR
S-TEC DME-450**

This supplement must be attached to the Pilot's Operating Handbook and FAA Approved Airplane Flight Manual when the S-TEC DME-450 is installed per the Equipment List. The information contained herein supplements or supersedes the Pilot's Operating Handbook and FAA Approved Airplane Flight Manual only in those areas listed herein. For limitations, procedures and performance information not contained in this supplement, consult the Pilot's Operating Handbook and FAA Approved Airplane Flight Manual.

FAA APPROVED: Christina L. Marsh
CHRISTINA L. MARSH
D.O.A. NO. SO- 1
THE NEW PIPER AIRCRAFT, INC.
VERO BEACH, FLORIDA

DATE OF APPROVAL: January 12, 2001

SECTION 1 - GENERAL

The S-TEC DME-450 system is a full feature, solid state, remote mounted system with full 200 channel capability. For long distance operation, it provides a full 100 watts maximum pulse power transmitter output.

The IND-450 indicator (see figure 1) provides selectable read-out of distance to/from the station, ground speed, and time to/from the station. Features also include automatic display dimming and waypoint annunciation.

SECTION 2 - LIMITATIONS

No change.

SECTION 3 - EMERGENCY PROCEDURES

No change.

SECTION 4 - NORMAL PROCEDURES

DME OPERATION

- DME Mode Selector Switch - Set to DME 1 or DME 2
- NAV 1 and NAV 2 VHF Navigation Receivers - ON; SET FREQUENCY to VOR/DME station frequencies, as required.

NOTE

When the VOR frequency is selected, the appropriate DME Frequency is automatically channeled.

- DME audio selector button (on audio selector panel) - SET to desired mode.

SECTION 5 - PERFORMANCE

No change.

SECTION 6 - WEIGHT AND BALANCE

Factory installed optional equipment is included in the licensed weight and balance data in Section 6 of the Pilot's Operating Handbook and Airplane Flight Manual.

SECTION 7 - DESCRIPTION AND OPERATION**IND-450**

Figure 1

1. **DISTANCE DISPLAY (NM)** - DME distance to VORTAC/WAYPOINT displayed in .1 nautical mile increments up to 99.9 NM, then in increments of one nautical mile.
2. **GROUND SPEED DISPLAY (KTS)** - Displays ground speed in knots to or from VORTAC/WAYPOINT up to 999 knots (aircraft must be flying directly to or from the VORTAC/WAYPOINT for true ground speed indication).
3. **TIME TO STATION DISPLAY (MIN)** - Displays time to station (VORTAC/WAYPOINT) in minutes up to 99 minutes (aircraft must be flying directly to or from the VORTAC/WAYPOINT for true time to the station indication).

7 - DESCRIPTION AND OPERATION (continued)

4. DME ON/OFF SWITCH - Turns DME power on or off.

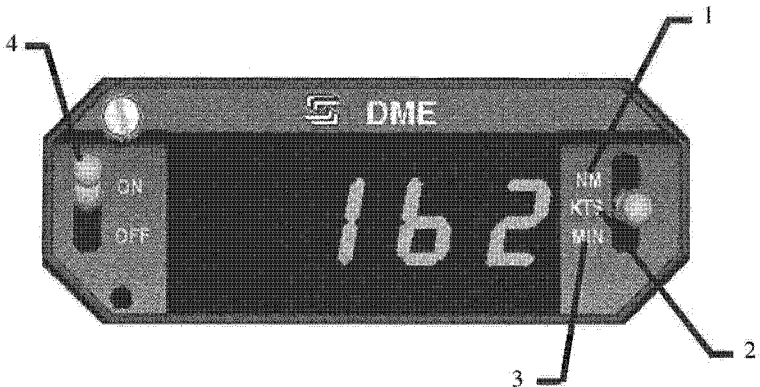
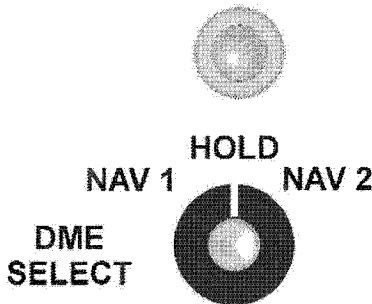

Mode Selector Switch
Figure 2

5. DME MODE SELECTOR SWITCH (NAV 1, HOLD, NAV 2) - Selects DME operating mode as follows:

NAV 1 - Selects DME operation with NO. 1 VHF navigation set; enables channel selection by NAV 1 frequency selector controls.

HOLD - Selects DME memory circuit; DME remains channeled to station to which it was last channeled when HOLD was selected and will continue to display information relative to this channel. Allows both the NAV 1 and NAV 2 navigation receivers to be set to new operational frequencies without affecting the previously selected DME operation.

NOTE

In the HOLD mode there is no annunciation of the VOR/DME station frequency. However, an annunciator light located above the HOLD position of the selector illuminates to inform the pilot that the DME is in the HOLD mode.

NAV 2 - Selects DME operation with NO. 2 VHF navigation set; enables channel selection by NAV 2 frequency selector controls.

**PILOT'S OPERATING HANDBOOK
AND
FAA APPROVED AIRPLANE FLIGHT MANUAL**

**SUPPLEMENT NO. 15
FOR
BF GOODRICH AEROSPACE
WX-500 STORMSCOPE - SERIES II WEATHER MAPPING SENSOR**

This supplement must be attached to the Pilot's Operating Handbook and FAA Approved Airplane Flight Manual when the BF Goodrich Aerospace WX-500 Stormscope is installed per the equipment list. The information contained herein supplements or supersedes the Pilot's Operating Handbook and FAA Approved Airplane Flight Manual only in those areas listed herein. For limitations, procedures and performance information not contained in this supplement, consult the Pilot's Operating Handbook and FAA Approved Airplane Flight Manual.

FAA APPROVED:



ALBERT J. MILL
D.O.A. NO. SO- 1
THE NEW PIPER AIRCRAFT, INC.
VERO BEACH, FLORIDA

DATE OF APPROVAL: November 8, 2002

SECTION 1 - GENERAL

This supplement provides information necessary for the operation of the aircraft with the BF Goodrich WX-500 Stormscope.

WARNING

Never use your Stormscope system to attempt to penetrate a thunderstorm. The FAA Advisory Circular, Subject: Thunderstorms, and the Airman's Information Manual (AIM) recommend that a pilot "avoid by at least 20 miles any thunderstorm identified as severe or giving an intense radar echo."

CAUTION

There are several atmospheric phenomena other than nearby thunderstorms that can cause isolated discharge points in the strike display mode. Clusters of two or more discharge points in the strike display mode, however, do indicate thunderstorm activity when they reappear after clearing the screen. Avoid the clusters and you'll avoid the thunderstorms. In the cell display mode, even a single discharge point may represent thunderstorm activity and should be avoided.

SECTION 2 - LIMITATIONS

The BF Goodrich Aerospace WX-500 Stormscope Users Guide, p/n 009-11501-001, Rev. A, dated September 10, 1997, or later appropriate revision, must be immediately available to the flight crew whenever weather avoidance is predicated on the use of this system.

SECTION 3 - EMERGENCY PROCEDURES

No change.

SECTION 4 - NORMAL PROCEDURES

Normal operating procedures are described in the BF Goodrich Aerospace WX-500 Stormscope Users Guide, p/n 009-11501-001, Rev. A, dated September 10, 1997, or later appropriate revision.

SECTION 5 - PERFORMANCE

No change.

SECTION 6 - WEIGHT AND BALANCE

Factory installed optional equipment is included in the licensed empty weight and balance data in Section 6 of the Pilot's Operating Handbook.

SECTION 7 - DESCRIPTION AND OPERATION

A. OPERATING PROCEDURES

See the BF Goodrich Aerospace WX-500 Stormscope Users Guide for a complete description of the WX-500 system.

B. PILOT'S DISPLAY (Airplane Dependent)

The BF Goodrich Aerospace WX-500 Stormscope's data will appear on either the Garmin GNS 530 or the Garmin GNS 430.

THIS PAGE INTENTIONALLY LEFT BLANK

**PILOT'S OPERATING HANDBOOK
AND
FAA APPROVED AIRPLANE FLIGHT MANUAL**

**SUPPLEMENT NO. 16
FOR
S-TEC ADF-650D SYSTEM**

This supplement must be attached to the Pilot's Operating Handbook and FAA Approved Airplane Flight Manual when the S-TEC ADF-650D System is installed per the equipment list. The information contained herein supplements or supersedes the Pilot's Operating Handbook and FAA Approved Airplane Flight Manual only in those areas listed herein. For limitations, procedures, performance and loading information not contained in this supplement, consult the Pilot's Operating Handbook and FAA Approved Airplane Flight Manual.

FAA APPROVED:



ALBERT J. MILL
D.O.A. NO. SO- 1
THE NEW PIPER AIRCRAFT, INC.
VERO BEACH, FLORIDA

DATE OF APPROVAL: January 20, 2003

SECTION 1 - GENERAL

This supplement supplies information necessary for the operation of the airplane when the S-TEC ADF-650D System is installed in accordance with FAA approved Piper data.

SECTION 2 - LIMITATIONS

No change.

SECTION 3 - EMERGENCY PROCEDURES

No change.

SECTION 4 - NORMAL PROCEDURES

To turn on the ADF-650D System:

- Depress the PWR button momentarily and release.

NOTE

If the PWR button is pressed for longer than 3 seconds, the receiver will immediately shut off.

- After successful self test, input desired station frequency and select ANT mode.
- Positively identify selected station or beacon.
- Adjust volume control as required.
- If ADF-650D System is used for navigation, select ADF or BFO mode immediately after the station has been positively identified.

To turn off the ADF-650D System:

- Depress the PWR button for at least 3 seconds.

NOTE

If the PWR button is released within 3 seconds, normal operations will resume.

SECTION 4 - NORMAL PROCEDURES (continued)

To perform the preflight checklist and self test:

- After successful self test, press the mode control until ANT is displayed and input a predetermined frequency to select a station in the immediate area. Adjust the volume control as necessary to provide a comfortable listening level.
- Press the ID button and observe that the station identification code becomes louder (if the station is voice-identified, it is not necessary to press the ID button).
- Press the ID button again to cancel the IDENT function and press the mode control until ADF is displayed.
- Observe the IND-650A Indicator and note that the bearing pointer indicates the relative bearing to the station.
- Push the TEST button while observing the indicator bearing pointer. The bearing pointer will rotate 90° and stop.
- Push the TEST button again (to turn off test function). The bearing pointer returns to the original relative bearing position.
- Switch to BFO mode, if appropriate, and verify a tone is present. Select the appropriate operating mode when all checks have been completed.

SECTION 5 - PERFORMANCE

No change.

SECTION 6 - WEIGHT AND BALANCE

Factory installed optional equipment is included in the licensed weight and balance data in Section 6 of the Pilot's Operating Handbook and Airplane Flight Manual.

SECTION 7 - DESCRIPTION AND OPERATION

The S-TEC ADF-650D System operates over a frequency range of 200 through 1799 kHz in 1-kHz increments. Three operating modes are included as part of the ADF-650D System.

- BFO
- ADF
- ANT

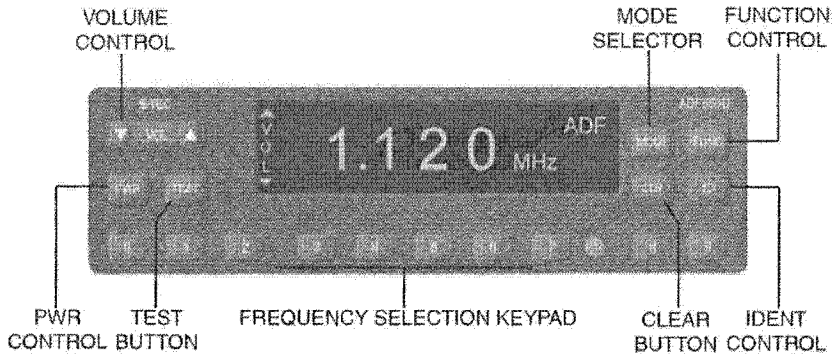

RCR-650D Receiver Controls

Beat Frequency Oscillator (BFO) Mode

The BFO (beat frequency oscillator) mode is used to aurally identify stations that employ keyed CW (Carrier Wave) rather than amplitude modulation techniques. This mode activates the bearing pointer. The bearing pointer will point in the direction of the station relative to the aircraft heading.

NOTE

CW signals (Morse Code) are unmodulated and no audio will be heard without use of BFO. This type of signal is not used in the United States air navigation. It is used in some foreign countries and marine beacons.

SECTION 7 - DESCRIPTION AND OPERATION (continued)

Automatic Direction Finder (ADF) Mode

The Automatic Direction Finder (ADF) mode uses conventional nondirectional beacons and AM broadcast stations for navigation. This mode activates the bearing pointer. The bearing pointer will point in the direction of the station relative to the aircraft heading.

Antenna (ANT) Mode

The ANT (antenna) mode cannot be used for navigation; this mode enhances audio reception clarity and is normally used for station identification.

Frequency Selection Keypad

The Frequency Selection Keypad is used to select the system operating frequency. The keypad consists of a row of numbered buttons from 0 to 9, located along the bottom of the RCR-650D Receiver. Frequencies in the megahertz and kilohertz range may be selected.

Power (PWR) Control

The power control is used to turn the receiver on and off. Momentarily depressing the PWR button will turn the receiver on and also initiate a self test.

NOTE

If the PWR button is pressed for longer than 3 seconds the receiver will immediately shut off.

SECTION 7 - DESCRIPTION AND OPERATION (continued)

Clear (CLR)

The clear function offers several options for the operator.

- If the entire frequency is entered and the CLR button is pushed, all the numbers will become dashes. An additional push on the CLR button will restore and display the prior frequency entry.
- If an entry is in progress and a number is entered in error, pressing the CLR button will erase the last number entry.
- Pressing the CLR button while in the contrast function reverses the display image and also places the receiver in manual mode.

NOTE

It is not necessary to push CLR to enter a new frequency number. Simply complete the entry and then enter the new numbers and they will replace the old frequency.

Volume (VOL) Control

The audio volume control is used to adjust the settings and levels for all function selector and setup modes and is controlled by pressing the **▲** and **▼** buttons on the VOL control.

SECTION 7 - DESCRIPTION AND OPERATION (continued)

Function (FUNC) Selector

The function selector enables the user to select between contrast and volume display functions (on power-up, the RCR-650D will be in the volume display function). The first time the function selector is pressed, the receiver enters the contrast function. Subsequent presses of the function selector button toggles the unit between contrast and volume. Additionally, pressing the clear button while in the contrast function places the receiver in manual mode. In manual mode, subsequent pushes of the function selector will cycle the receiver through four functions: volume, contrast, display and keypad.

- **Volume**



The volume control function is available on power-up and is accessed immediately by pressing the **▲** and **▼** buttons on the VOL control. Upon activation, the kHz and mode annunciations are temporarily replaced by the text "VOLUME" with a horizontal fill bar. The filled portion of the bar indicates the current volume setting.

- **Contrast**



The contrast function is activated by pressing the FUNC selector. Upon activation, the kHz and mode annunciation are temporarily replaced by the text "CONTRAST" with a horizontal fill bar on the right side of the annunciator panel. The filled portion of the bar indicates the current contrast setting. The contrast is adjusted by pressing the appropriate **▲** and **▼** indicators on the volume control.

- **Display**



When the display is setup in the manual mode, press the FUNC selector until the display function is selected. The display function is then activated and the kHz and mode annunciations are temporarily replaced by the text "DISPLAY" with a horizontal fill bar on the right side of the annunciator panel. The filled portion of the bar indicates the current display setting. The display is adjusted by pressing the appropriate **▲** and **▼** indicators on the volume control.

SECTION 7 - DESCRIPTION AND OPERATION (continued)**Function (FUNC) Selector - continued**

- **Keypad Light Brightness**



The keypad light brightness setting is used to adjust the brightness of all legends on the display face. When the display is setup in the manual mode, press the FUNC selector until the keypad function is selected. The keypad function is then displayed with the text "KEYPAD" and a horizontal fill bar on the right side of the annunciator panel. The filled portion of the bar indicates the current keypad brightness setting. The brightness is adjusted by pressing the appropriate \wedge and \vee indicators on the volume control.

Mode Selector

The mode selector is used to select one of the three operating states: BFO, ADF, or ANT. Pressing the MODE selector button will step the receiver through the three modes. The current mode will be displayed in the upper right corner of the display. On system power-up, the mode selector will be in the ADF mode.

Ident (ID)

The receiver utilizes an Ident Filter for audio output which aids in receiving weak signals. Pressing the ID button toggles the Ident Filter on and off. When the Ident Filter is active, the text "IDENT" is displayed in the bottom right corner of the display.

SECTION 7 - DESCRIPTION AND OPERATION (continued)

Test Mode



Press the TEST button to start the test mode. The text "TEST" will be displayed in the bottom right corner of the display for approximately 15 seconds. During this time, the IND-650A Indicator pointer will incrementally rotate 90°. Press the TEST button again to cancel the test while in this mode. The pointer will immediately return to its starting point.

**PILOT'S OPERATING HANDBOOK
AND
FAA APPROVED AIRPLANE FLIGHT MANUAL**

**SUPPLEMENT NO. 17
FOR
GARMIN GTX 330 TRANSPONDER**

This supplement must be attached to the Pilot's Operating Handbook and FAA Approved Airplane Flight Manual when the Garmin GTX 330 Transponder is installed per the Equipment List. The information contained herein supplements or supersedes the Pilot's Operating Handbook and FAA Approved Airplane Flight Manual only in those areas listed herein. For limitations, procedures and performance information not contained in this supplement, consult the Pilot's Operating Handbook and FAA Approved Airplane Flight Manual.

FAA APPROVED:



ALBERT J. MILL
D.O.A. NO. SO - 1
THE NEW PIPER AIRCRAFT, INC.
VERO BEACH, FLORIDA

DATE OF APPROVAL: January 20, 2004

ISSUED: JULY 12, 1995
REVISED: JANUARY 20, 2004

REPORT: VB-1616
1 of 4, 9-125

SECTION 1 - GENERAL

This supplement supplies information necessary for the operation of the airplane when the Garmin GTX 330 Transponder is installed in accordance with FAA approved Piper data.

SECTION 2 - LIMITATIONS

- A. Display of TIS traffic information is advisory only and does not relieve the pilot responsibility to "see and avoid" other aircraft. Aircraft maneuvers shall not be predicated on the TIS displayed information.
- B. Display of TIS traffic information does not constitute a TCAS I or TCAS II collision avoidance system as required by 14 CFR Part 121 or Part 135.
- C. Title 14 of the Code of Federal Regulations (14 CFR) states that "When an Air Traffic Control (ATC) clearance has been obtained, no pilot-in-command (PIC) may deviate from that clearance, except in an emergency, unless he obtains an amended clearance." Traffic information provided by the TIS up-link does not relieve the PIC of this responsibility.
- D. The 400/500 Series Garmin Display Interfaces (Pilot's Guide Addendum) P/N 190-00140-13 Rev. A or later revision must be accessible to the flight crew during flight.
- E. 400/500 Series Main Software 4.00 or later FAA approved software is required to operate the TIS interface and provide TIS functionality.

SECTION 3 - EMERGENCY PROCEDURES

To transmit an emergency signal:

- Mode Selection Key - ALT
- Code Selection - SELECT 7700

To transmit a signal representing loss of all communications:

- Mode Selection Key - ALT
- Code Selection - SELECT 7600

SECTION 4 - NORMAL PROCEDURES**BEFORE TAKEOFF:**

- To transmit Mode C (Altitude Reporting) code in flight:
- Mode Selection Key - ALT
- Code Selector Keys - SELECT assigned code.

To transmit Mode A (Aircraft Identification) code in flight:

- Mode Selector Key - ON
- Code Selector Keys - SELECT assigned code.

NOTE

During normal operation with the ON mode selected, the reply indicator "R" flashes, indicating transponder replies to interrogations.

NOTE

Mode A reply codes are transmitted in ALT also; however, Mode C codes only are suppressed when the Function Selector ON key is selected.

1. DETAILED TRANSPONDER OPERATING PROCEDURES

Normal transponder operating procedures are described in the GARMIN GTX 330 Pilot's Guide, P/N 190-00207-00, Rev. A, or later appropriate revision.

2. DISPLAY OF TRAFFIC INFORMATION SERVICE (TIS) DATA

TIS surveillance data uplinked by Air Traffic Control (ATC) radar through the GTX 330 Mode S Transponder will appear on the interfaced display device (Garmin 400 or 500 series products). For detailed operating instructions and information regarding the TIS interface, refer to the 400/500 Series Garmin Display Interfaces (Pilot's Guide Addendum) P/N 190-00140-13 Rev. A or later appropriate revision.

SECTION 5 - PERFORMANCE

No change.

SECTION 6 - WEIGHT AND BALANCE

Factory installed optional equipment is included in the licensed weight and balance data in section 6 of the Airplane Flight Manual.

SECTION 7 - DESCRIPTION AND OPERATION

See the 400/500 Series Garmin Display Interfaces (Pilot's Guide Addendum), P/N 190-00140-13, and GTX 330 Pilot's Guide, P/N 190-00207-00, for a complete description of the GTX 330 system.

TABLE OF CONTENTS

SECTION 10

OPERATING TIPS

Paragraph No.	Page No.
10.1 General.....	10-1
10.3 Operation Tips.....	10-1

THIS PAGE INTENTIONALLY LEFT BLANK

SECTION 10

OPERATING TIPS

10.1 GENERAL

This section provides operating tips of particular value in the operation of the Piper Seminole.

10.3 OPERATING TIPS

- (a) Learn to trim for takeoff so that only a very light back pressure on the wheel is required to lift the airplane off the ground.
- (b) On takeoff, do not retract the gear prematurely. The airplane may settle and make contact with the ground because of lack of flying speed, atmospheric conditions, or rolling terrain.
- (c) Flaps may be lowered at airspeeds up to 111 KIAS. To reduce flap operating loads, it is desirable to have the airplane at a slower speed before extending the flaps. The flap step will not support weight if the flaps are in any extended position. The flaps must be placed in the UP position before they will lock and support weight on the step.
- (d) Before attempting to reset any circuit breaker, allow a two to five minute cooling off period.
- (e) Always determine position of landing gear by checking the gear position lights.
- (f) The shape of the nacelle fuel tanks is such that in certain maneuvers and with low fuel levels, the fuel may move away from the tank outlet. If the outlet is uncovered, the fuel flow will be interrupted and a temporary loss of power may result. Pilots can prevent inadvertent uncovering of the outlet by avoiding maneuvers which could result in uncovering the outlet.

10.3 OPERATING TIPS (Continued)

Extreme running turning takeoffs should be avoided.

Prolonged slips and skids which result in excess of 2000 feet of altitude loss, or other radical or extreme maneuvers which could cause uncovering of the fuel outlet must be avoided as fuel flow interruption may occur when the tank being used is not full.

- (g) The rudder pedals are suspended from a torque tube which extends across the fuselage. The pilot should become familiar with the proper positioning of his feet on the rudder pedals so as to avoid interference with the torque tube when moving the rudder pedals or operating the toe brakes.
- (h) Anti-collision lights should not be operating when flying through clouds, fog, or haze, since reflected light can produce spacial disorientation. Strobe lights should not be used in close proximity to the ground such as during taxiing, takeoff or landing.
- (i) In an effort to avoid accidents, pilots should obtain and study the safety related information made available in FAA publications such as regulations, advisory circulars, Aviation News, AIM and safety aids.
- (j) Pilots who fly above 10,000 feet should be aware of the need for special physiological training. Appropriate training is available at approximately twenty-three Air Force Bases throughout the United States for a small fee. The training is free at the NASA Center in Houston and at the FAA Aeronautical Center in Oklahoma.

Forms to be completed (Physiological Training Application and Agreement) for application for the training course may be obtained by writing to the following address:

Chief of Physiological Training, AAC-143
FAA Aeronautical Center
P. O. Box 25082
Oklahoma City, Oklahoma 73125

It is recommended that all pilots who plan to fly above 10,000 feet take this training before flying this high and then take refresher training every two or three years.

10.3 OPERATING TIPS (Continued)

- (k) Sluggish RPM control and propeller overspeed with poor RPM recovery after rapid throttle application are indications that nitrogen pressure in the propeller dome is low.
- (l) Experience has shown that the training advantage gained by pulling a mixture control or turning off the fuel to simulate engine failure at low altitude is not worth the risk assumed, therefore it is recommended that instead of using either of these procedures to simulate loss of power at low altitude, the throttle be retarded slowly to idle position. Fast reduction of power may be harmful to the engine. See Section 4 for power settings which are recommended for simulated one engine operation.
- (m) Before starting either engine, check that all radio switches, light switches and the pitot heat switch are in the OFF position so as not to create an overloaded condition when the starter is engaged.
- (n) The airplane should not be flown in severe turbulence as damage to the airframe structure could result.
- (o) The best speed for takeoff is about 75 KIAS under normal conditions. Trying to pull the airplane off the ground at too low an airspeed decreases the controllability of the airplane in the event of an engine failure.

THIS PAGE INTENTIONALLY LEFT BLANK