

## WEIGHT AND BALANCE

In order to achieve the performance and flying characteristics which are designed into the aircraft, the Arrow must be flown with the weight and center of gravity (C.G.) position within the approved envelope. The aircraft offers flexibility of loading. However, you cannot fill the aircraft, with four adults, full fuel tanks and maximum baggage. With the flexibility comes responsibility. The pilot must insure that the airplane is loaded within the loading envelope before he makes a takeoff.

Misloading carries consequences for any aircraft. An overloaded airplane will not take off, climb or cruise as well as when it is properly loaded. The heavier the airplane is loaded the less climb performance it will have.

Center of gravity is a determining factor in flight characteristics. If the C.G. is too far forward in any airplane, it may be difficult to rotate for takeoff or landing. If the C.G. is too far aft, the airplane may rotate prematurely on takeoff or try to pitch up during climb. Longitudinal stability will be reduced. This can lead to inadvertent stalls and even spins; and spin recovery becomes more difficult as the center of gravity moves aft of the approved limit.

A properly loaded aircraft, however, will perform as intended. Before the aircraft is licensed, the Arrow is weighed and a licensed empty weight and C.G. location computed. Using the licensed empty weight and C.G. location, the pilot can easily determine the weight and C.G. position for the loaded airplane by computing the total weight and moment and then determining whether they are within the approved envelope.

The licensed empty weight and C.G. location for a particular airplane are recorded in the weight and balance section of the Airplane Flight Manual. The current values should always be used. Whenever new equipment is added or any modification work is done, the mechanic responsible for the work is required to compute a new basic empty weight and C.G. position and to write these in the aircraft log book. The owner should make sure that it is done.

A weight and balance calculation is necessary in determining how much fuel or baggage can be boarded so as to keep within allowable limits. Check calculations prior to adding fuel to insure against improper loading.

The following pages are forms used in weighing an airplane in production and in computing empty weight, C.G. position, and useful load. Note that the useful load includes fuel, oil, baggage, cargo and passengers. Following this is the method for computing takeoff weight and C.G.

ARROW

---

THIS PAGE INTENTIONALLY LEFT BLANK

REPORT: VB-549 PAGE 5-2  
MODEL: PA-28R-200

ISSUED: MAY 14, 1973

---

## WEIGHT AND BALANCE DATA

### WEIGHING PROCEDURE

At the time of licensing, Piper Aircraft Corporation provides each airplane with the licensed empty weight and center of gravity location. This data is on Page 5-7.

The removal or addition of an excessive amount of equipment or excessive airplane modifications can affect the licensed empty weight and empty weight center of gravity. The following is a weighing procedure to determine this licensed empty weight and center of gravity location:

#### 1. PREPARATION

- a. Be certain that all items checked in the airplane equipment list are installed in the proper location in the airplane.
- b. Remove excessive dirt, grease, moisture, foreign items such as rags and tools from the airplane before weighing.
- c. Defuel airplane. Then open all fuel drains until all remaining fuel is drained. Operate engine on each tank until all undrainable fuel is used and engine stops.

#### CAUTION

Whenever the fuel system is completely drained and fuel is replenished it will be necessary to run the engine for a minimum of 3 minutes at 1000 RPM on each tank to insure no air exists in the fuel supply lines.

- d. Drain all oil from the engine, by means of the oil drain, with the airplane in ground attitude. This will leave the undrainable oil still in the system. Engine oil temperature should be in the normal operating range before draining.
- e. Place pilot and copilot seats in fourth (4th) notch, aft of forward position. Put flaps in the fully retracted position and all control surfaces in the neutral position. Tow bar should be in the proper location and all entrance and baggage doors closed.
- f. Weigh the airplane inside a closed building to prevent errors in scale readings due to wind.

#### 2. LEVELING

- a. With airplane on scales, block main gear oleo pistons in the fully extended position.

**ARROW**

- b. Level airplane (see diagram) deflating nose wheel tire, to center bubble on level.

**3. WEIGHING - AIRPLANE EMPTY WEIGHT**

- a. With the airplane level and brakes released, record the weight shown on each scale. Deduct the tare, if any, from each reading.

Scale Position and Symbol	Scale Reading	Tare	Weight
Nose Wheel (N)			
Right Main Wheel (R)			
Left Main Wheel (L)			
Airplane Empty Weight, as Weighed (T)			

**4. EMPTY WEIGHT CENTER OF GRAVITY**

- a. The following geometry applies to the PA-28R-200 airplane when airplane is level (See Item 2).

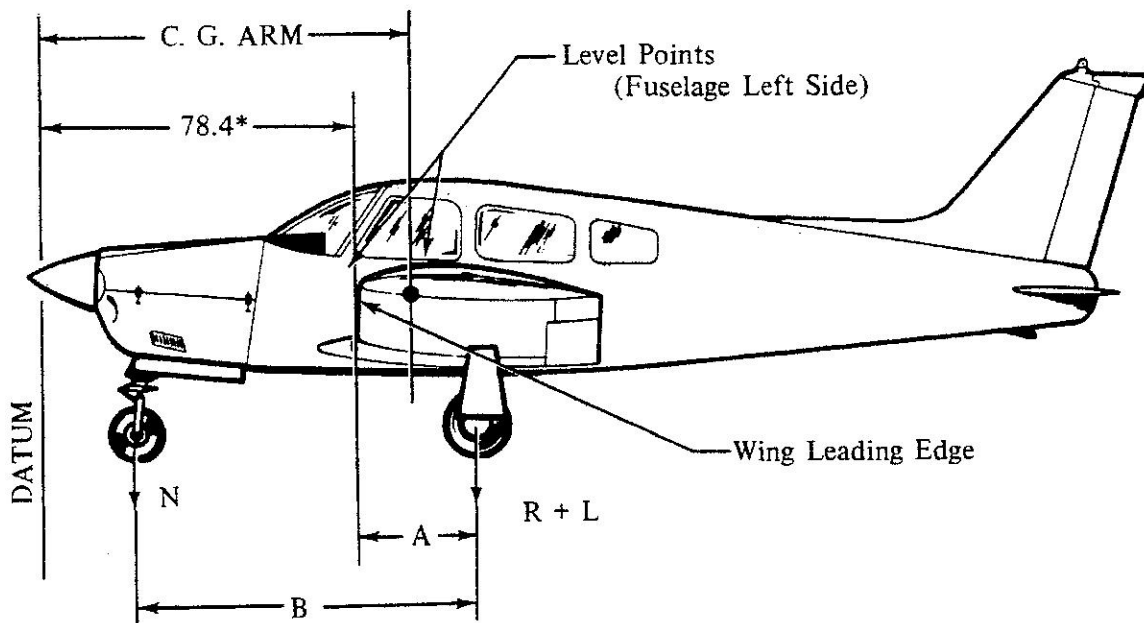

A =

B =

\* The datum is 78.4 inches ahead of the wing leading edge at the intersection of the straight and tapered section.

- b. Obtain measurement "A" by measuring from a plumb bob dropped from the wing leading edge, at the intersection of the straight and tapered section, horizontally and parallel to the airplane centerline, to the main wheel centerline.
- c. Obtain measurement "B" by measuring the distance from the main wheel centerline, horizontally and parallel to the airplane centerline, to each side of the nose wheel axle. Then average the measurements.
- d. The empty weight center of gravity (as weighed including optional equipment and undrainable oil) can be determined by the following formula:

$$\text{C.G. Arm} = 78.4 + A - \frac{B(N)}{T}$$

$$\text{C. G. Arm} = 78.4 + ( \quad ) - \frac{( \quad )( \quad )}{( \quad )} = \quad \text{inches}$$

#### 5. LICENSED EMPTY WEIGHT AND EMPTY WEIGHT CENTER OF GRAVITY

	Weight	Arm	Moment
Empty Weight (as weighed)			
Unusable Fuel (13 1/3 Pints)	+10.0	103.0	+1030
Licensed Empty Weight			

## WEIGHT AND BALANCE DATA

## MODEL PA-28R-200 CHEROKEE

Airplane Serial Number \_\_\_\_\_

Registration Number \_\_\_\_\_

Date \_\_\_\_\_

## AIRPLANE EMPTY WEIGHT

Item	Weight (Lbs)	C. G. Arm (Inches Aft of Datum)	Moment (In-Lbs)
*Empty Weight	Actual Computed		
Unusable Fuel (13-1/3 pints)	10.0	103.0	1030
Standard Empty Weight			
Optional Equipment			
Licensed Empty Weight			

\*Empty weight is defined as dry empty weight (including paint and hydraulic fluid) plus 1.8 lbs undrainable engine oil.

## AIRPLANE USEFUL LOAD - NORMAL CATEGORY OPERATION

(Gross Weight) - (Licensed Empty Weight) = Useful Load

(2650 lbs) - (        lbs) =        lbs

THIS LICENSED EMPTY WEIGHT, C.G. AND USEFUL LOAD ARE FOR THE AIRPLANE AS LICENSED AT THE FACTORY. REFER TO APPROPRIATE AIRCRAFT RECORD WHEN ALTERATIONS HAVE BEEN MADE.

### LOADING GRAPH

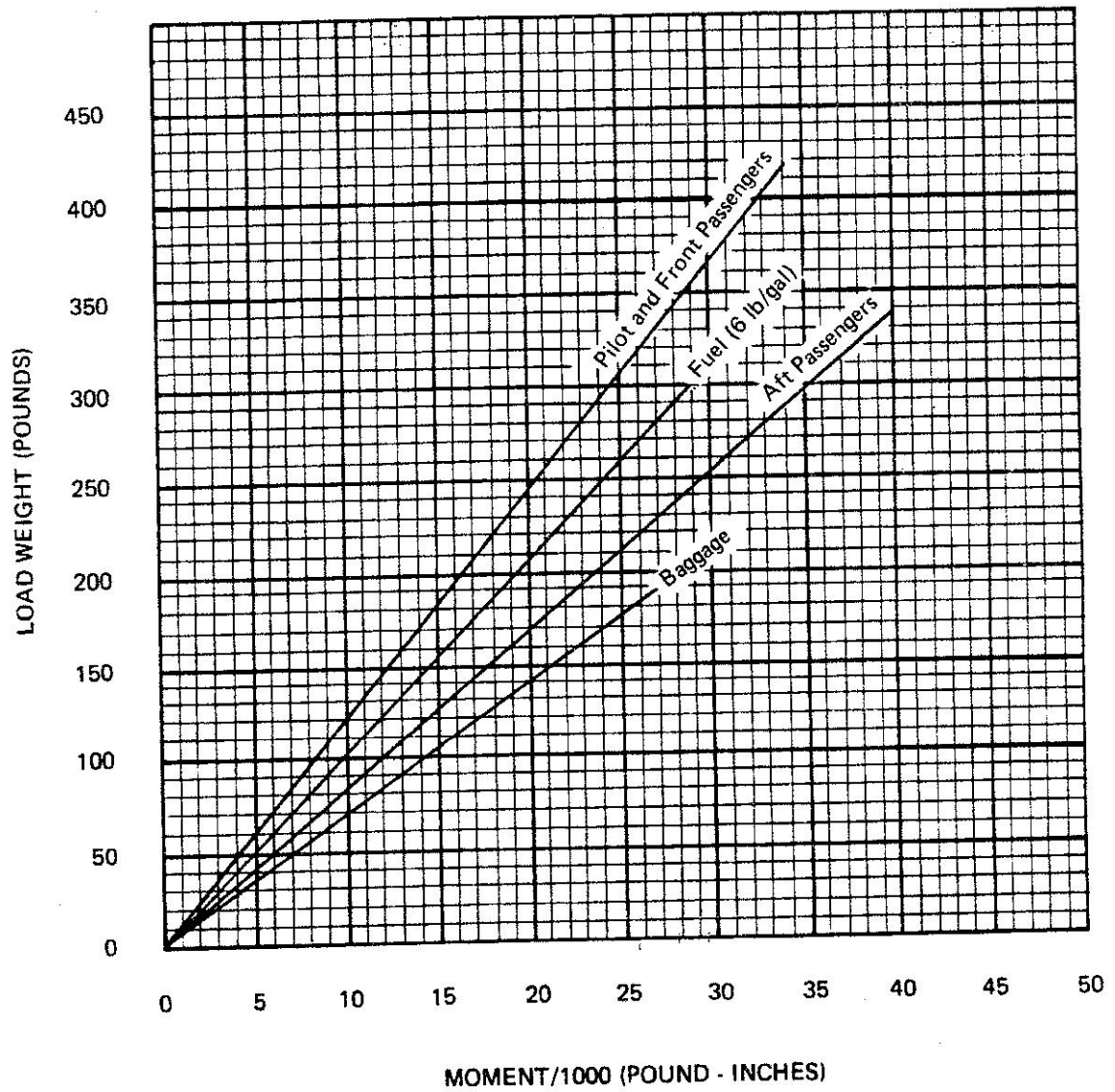

IT IS THE RESPONSIBILITY OF THE OWNER AND PILOT TO ASCERTAIN THAT THE AIRPLANE ALWAYS REMAINS WITHIN THE ALLOWABLE WEIGHT VS. CENTER OF GRAVITY ENVELOPE WHILE IN FLIGHT.

### C. G. RANGE AND WEIGHT

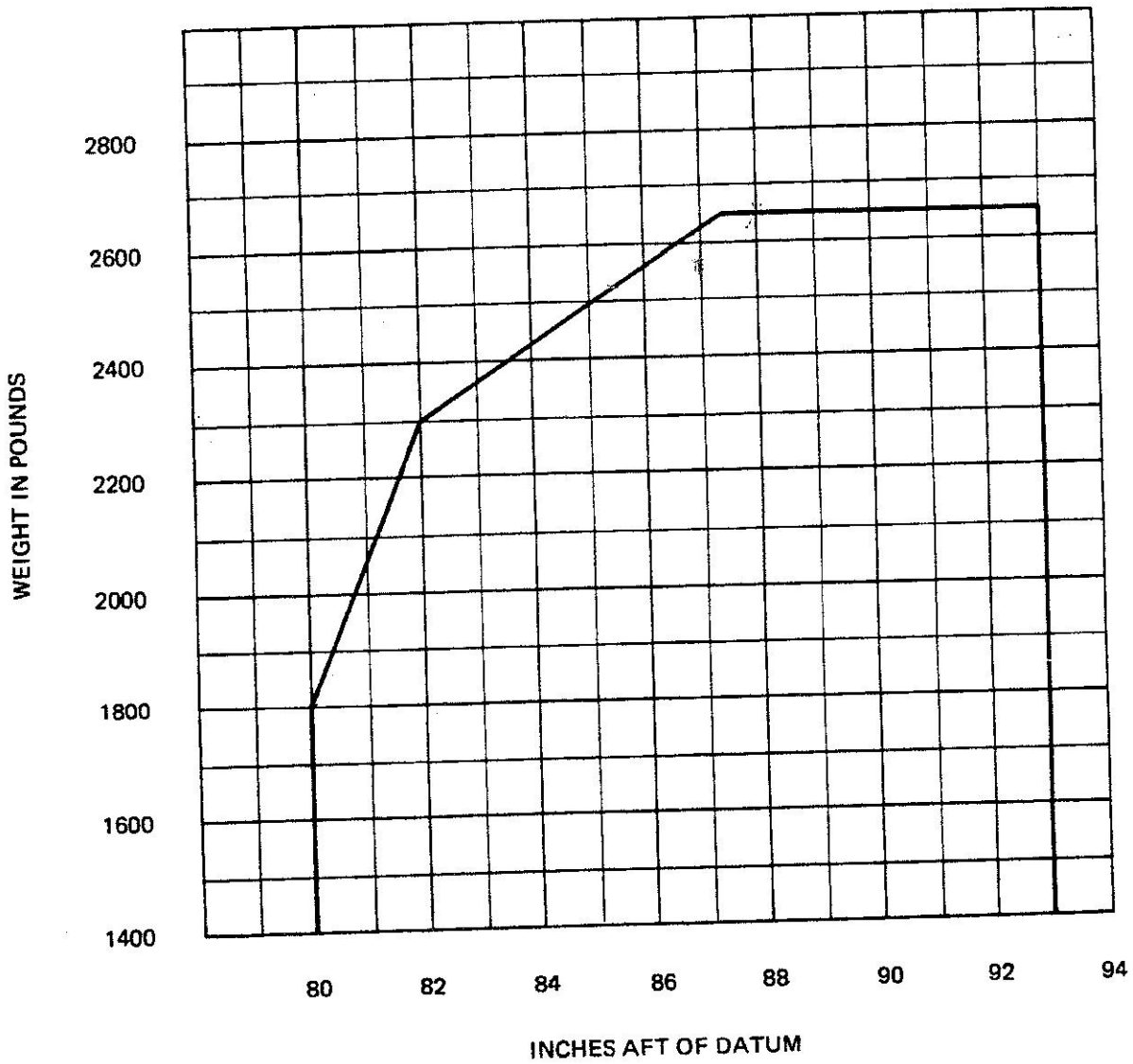

MOMENT DUE TO RETRACTING LANDING GEAR = +819 IN - LBS